

**EN\_IMPORTANT, RETAIN FOR FUTURE REFERENCE: READ CAREFULLY.**

**FR\_IMPORTANT: A LIRE ATTENTIVEMENT ET A CONSERVER POUR VOUS Y REFERRER ULTERIEUREMENT**

**ES\_IMPORTANTE, LEA DETENIDAMENTE Y GUARDE PARA FUTURAS REFERENCIAS.**

**PT\_IMPORTANTE, GUARDE PARA FUTURA REFERÊNCIA, LEIA ATENTAMENTE.**

**DE\_WICHTIG! SORFGFÄLTIG LESEN UND FÜR SPÄTERES NACHSCHLAGEN AUFBEWAHREN.**

**IT\_IMPORTANTE, LEGGERE E CONSERVARE QUESTO MANUALE D'ISTRUZIONE PER UN USO FUTURO.**

**RO\_IMPORTANT, DE PĂSTRAT PENTRU REFERINȚE VIITOARE: CITIȚI CU ATENȚIE.**

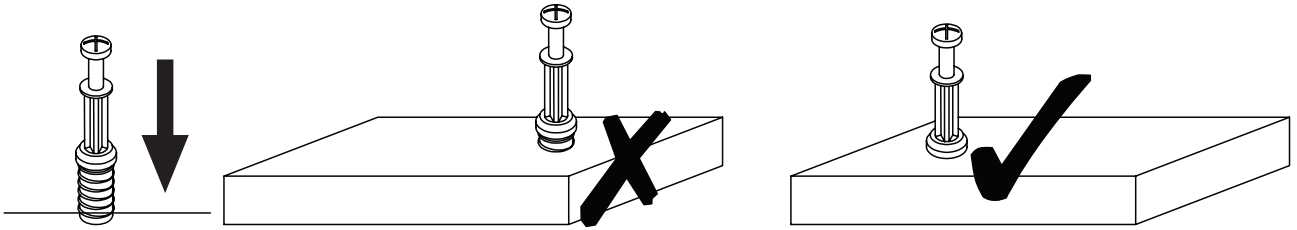

**EN\_ QUICKFIT:** Tighten quickfit until shoulder is flush with panel. Do not overtighten or undertighten.

**FR\_ RACCORD RAPIDE:** Faites serrer le raccord rapide jusqu'à ce que l'épaulement soit parfaitement encastré dans le panneau. Il ne faut ni trop serrer ni insuffisamment serrer.

**ES\_ QUICKFIT:** Apriete quickfit hasta que el hombro se descargue con el panel. NO lo sobreapriete ni lo apriete poco.

**PT\_ AJUSTE RÁPIDO:** Aperte o ajuste rápido até estar nivelada com o painel. Não apertar demasiado ou excessivamente.

**DE\_ QUICKFIT:** Ziehen Sie den Quickfit fest, bis die Schulter mit der Platte bündig ist. Bitte nicht zu fest oder zu schwach anziehen.

**IT\_ MONTAGGIO RAPIDO:** Stringere il montaggio rapido fino a quando la spalla è a filo con il pannello, non stringere troppo o troppo poco.

**RO\_ QUICKFIT:** Strângeți quickfit până când umărul este la același nivel cu panoul. Nu strângeți prea tare și nici prea slab.

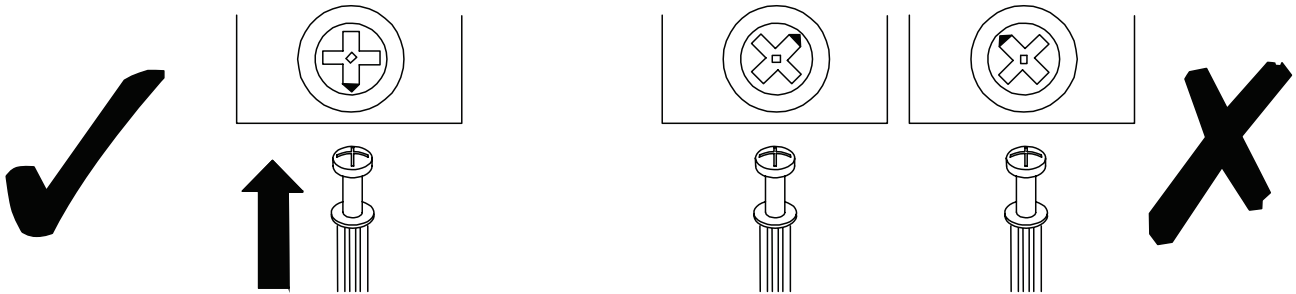

**EN\_ CAM LOCK:** When fitting cam lock, ensure starting position is correct before you insert connecting quickfit.

**FR\_ SERRURE BATTEUSE:** Avant d'insérer la serrure batteuse, veillez à la bonne orientation avant d'insérer le raccord rapide.

**ES\_ CIERRE DE LA CÁMARA:** Cuando instale el cierre de la cámara, asegúrese de que la posición de inicio es correcta antes de que inserte el quickfit conector.

**PT\_ BLOQUEIO:** Ao instalar o bloqueio, assegurar-se de que a posição inicial está correcta antes de inserir o encaixe de ligação rápida.

**DE\_ CAM-LOCK:** Achten Sie bei der Montage des Cam-Locks auf die richtige Ausgangsposition, bevor Sie den Quickfit einsetzen.

**IT\_ BLOCCAGGIO A CAMMA:** Quando si monta il bloccaggio a camma, assicurarsi che la posizione iniziale sia corretta prima di inserire il montaggio rapido di collegamento.

**RO\_ BLOCARE CU CAME:** Când montați blocarea cu came, asigurați-vă că poziția inițială este corectă înainte de a introduce racordul rapid.

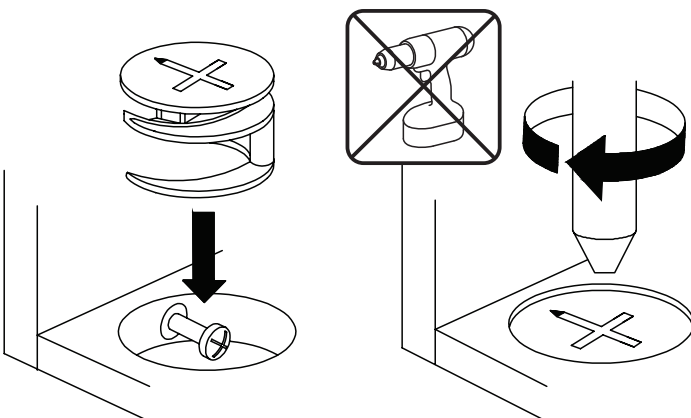

**EN\_ Turn cam lock clockwise to tighten.**

**FR\_ Faites tourner la serrure batteuse dans le sens des aiguilles d'une montre pour la resserrer.**

**ES\_ Gire el cierre de la cámara en sentido horario para apretarlo.**

**PT\_ Rodar o bloqueio no sentido dos ponteiros do relógio para o apertar.**

**DE\_ Drehen Sie den Cam-Lock im Uhrzeigersinn, um ihn festzuziehen.**

**IT\_ Ruotare il bloccaggio a camma in senso orario per stringere.**

**RO\_ Rotiți blocarea cu came în sensul acelor de ceasornic pentru a strânge.**

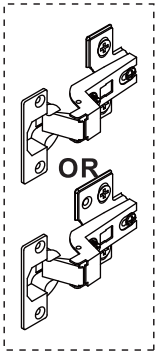

**EN\_** It may be necessary to adjust the hinges so that the doors align. Use the instructions below as a guide.  
**FR\_** Il est parfois nécessaire d'ajuster les charnières pour un meilleur alignement des portes. Servez-vous des instructions ci-dessous comme guide.  
**ES\_** Puede que sea necesario ajustar los quicios de forma que se alineen las puertas. Use las instrucciones que aparecen debajo como guía.  
**PT\_** Pode ser necessário ajustar as dobradiças para que as portas fiquem alinhadas. Utilizar as instruções abaixo como guia.  
**DE\_** Möglicherweise müssen Sie die Scharniere so einstellen, dass die Türen ausgerichtet sind. Verwenden Sie die nachstehenden Anweisungen als Leitfaden.  
**IT\_** Potrebbe essere necessario regolare le cerniere in modo che le porte siano allineate. Per fare ciò attenersi alle istruzioni sottostanti.  
**RO\_** Poate fi necesar să reglați balamalele pentru ca ușile să se alinieze. Folosiți instrucțiunile de mai jos ca ghid.

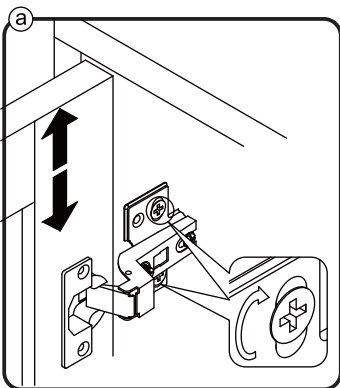

**EN\_** To adjust the door vertically loosen the screw as shown and move up and down as needed.  
**FR\_** Si vous souhaitez régler la porte verticalement, desserrez la vis comme indiqué et déplacez la porte de haut en bas selon les besoins.  
**ES\_** Para ajustar la puerta verticalmente afloje el tornillo tal y como se muestra y muévelo hacia arriba o hacia abajo según sea necesario.  
**PT\_** Para ajustar a porta na vertical, soltar o parafuso mostrado e mover-se para cima e para baixo, conforme necessário.  
**DE\_** Um die Tür vertikal auszurichten, lösen Sie die Schraube wie abgebildet und bewegen Sie sie nach Bedarf nach oben oder nach unten.  
**IT\_** Per allineare la porta verticalmente allentare la vite come mostrato e spostarla in alto o in basso secondo necessità.  
**RO\_** Pentru a regla ușa pe verticală, slăbiți șurubul așa cum se arată și mișcați în sus și în jos, după cum este necesar.

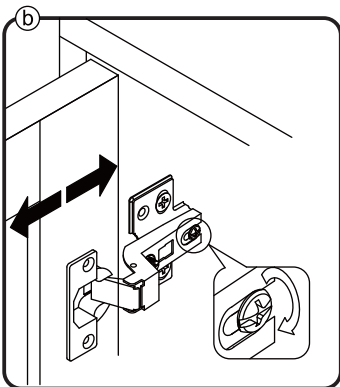

**EN\_** To adjust the gap from the door to the main frame turn the screw clockwise or anti-clockwise as needed.  
**FR\_** Si vous souhaitez ajuster l'écart entre la porte et le cadre principal, tournez la vis dans le sens des aiguilles d'une montre ou dans le sens inverse, si nécessaire.  
**ES\_** Para ajustar el espacio desde la puerta al marco principal, gire el tornillo en sentido horario o antihorario, según se necesite.  
**PT\_** Para ajustar o espaço entre a porta e o quadro principal, rode o parafuso no sentido dos ponteiros do relógio ou anti-horário, conforme necessário.  
**DE\_** Um den Abstand von der Tür zum Hauptrahmen auszurichten, drehen Sie die Schraube je nach Bedarf im oder gegen den Uhrzeigersinn.  
**IT\_** Per regolare lo spazio tra la porta e il telaio principale, avvitare o svitare la vite secondo necessità.  
**RO\_** Pentru a regla distanța dintre ușă și cadrul principal, rotiți șurubul în sensul acelor de ceasornic sau în sens invers acelor de ceasornic, după cum este necesar.

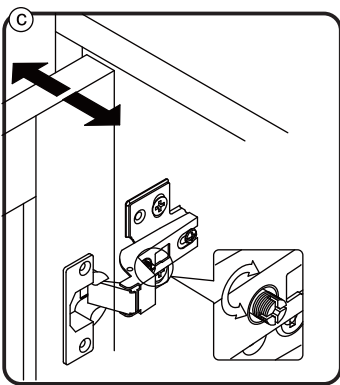

**EN\_** To adjust the door laterally adjust the screw as shown by turning clockwise or anti-clockwise.  
**FR\_** Si vous souhaitez ajuster la porte latéralement, ajustez la vis comme indiqué en tournant dans le sens des aiguilles d'une montre ou dans le sens inverse des aiguilles d'une montre.  
**ES\_** Para ajustar la puerta lateralmente ajuste el tornillo tal y como se muestra girándolo en sentido horario y antihorario.  
**PT\_** Para ajustar a porta lateralmente ajustar o parafuso, conforme indicado, rodando no sentido dos ponteiros do relógio ou no sentido anti-horário.  
**DE\_** Um die Tür seitlich auszurichten, stellen Sie bitte die Schraube wie abgebildet durch Drehen im oder gegen den Uhrzeigersinn ein.  
**IT\_** Per allineare la porta lateralmente regolare la vite come mostrato, avvitandola o svitandola.  
**RO\_** Pentru a regla ușa lateral, reglați șurubul așa cum se arată, rotindu-l în sensul acelor de ceasornic sau în sens invers acelor de ceasornic.

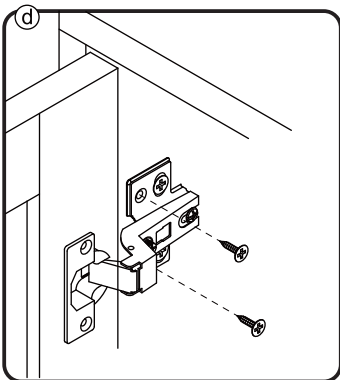

**EN\_** Please fix other screws  
**FR\_** Merci de serrer les autres vis.  
**ES\_** Fije los demás tornillos  
**PT\_** Por favor fixe os outros parafusos  
**DE\_** Befestigen Sie bitte die anderen Schrauben  
**IT\_** Fissare le altre viti  
**RO\_** Vă rugăm să fixați celelalte șuruburi.

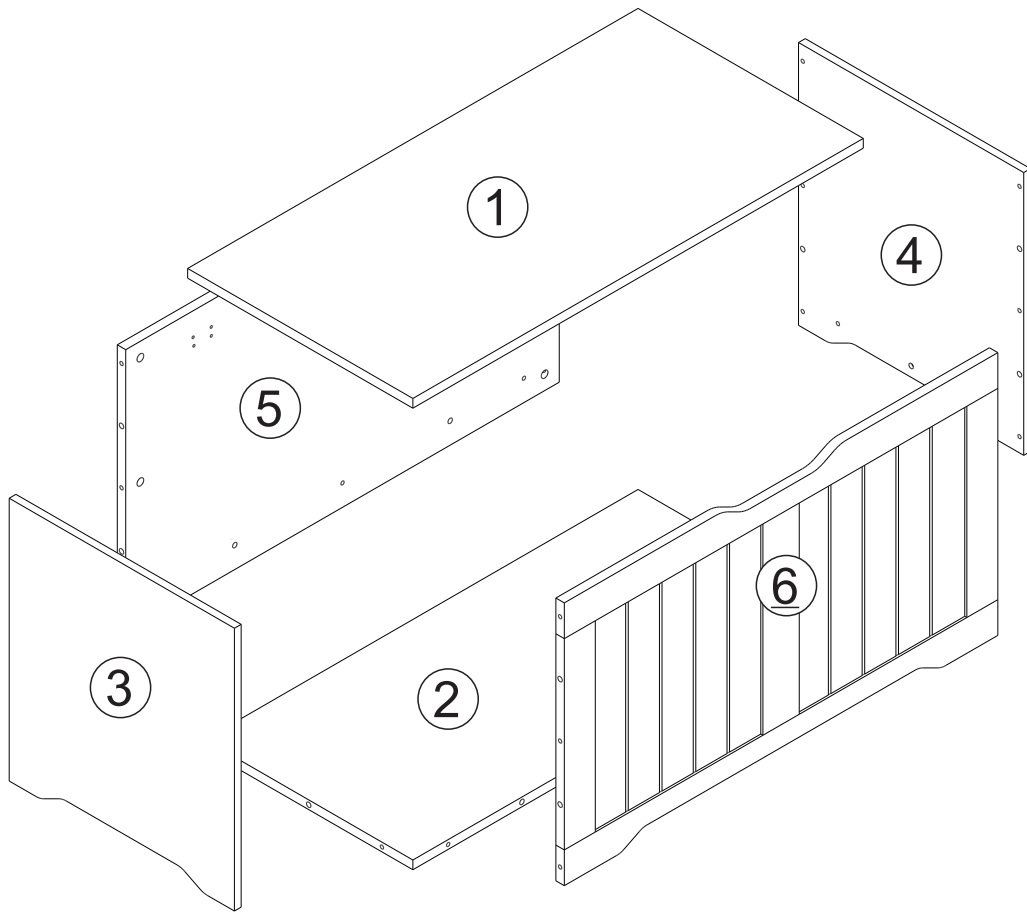

① x 1

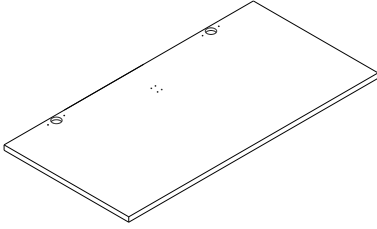

② x 1

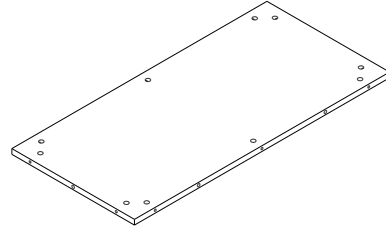

③ x 1

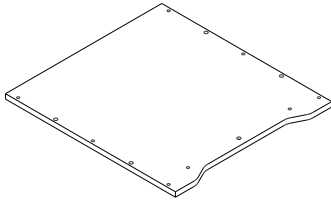

④ x 1

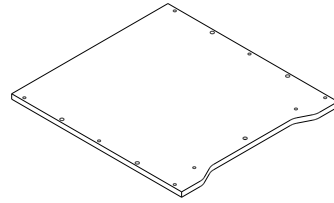



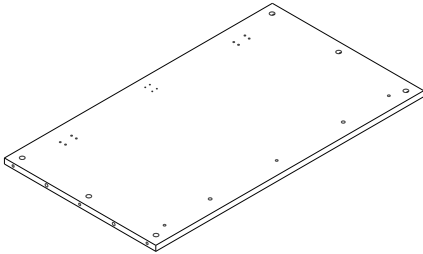



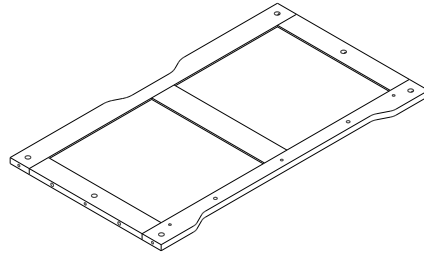

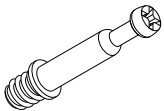
⑤ x 1

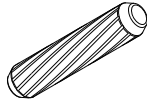

⑥ x 1

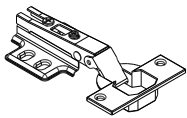
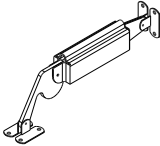

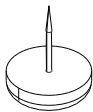
 <p><b>A</b> x 22 +2 (spare)</p>	 <p><b>B</b> x 22 +2 (spare)</p>	 <p><b>C</b> x 8 +2 (spare)</p>
 <p><b>D</b> x 6 6*30mm +1 (spare)</p>	 <p><b>E</b> x 8 8*30mm +1 (spare)</p>	 <p><b>F</b> x 20 3.5*14mm +2 (spare)</p>
 <p><b>G</b> x 2</p>	 <p><b>H</b> x 1</p>	 <p><b>I</b> x 2</p>
 <p><b>J</b> x 4</p>		

**EN:** Do not confuse similar screws.

**FR:** Ne pas confondre des vis similaires.

**ES:** No confunda tornillos similares.

**PT:** Não confunda parafusos semelhantes.

**DE:** Verwechseln Sie ähnliche Schrauben nicht.

**IT:** Non confondere le viti simili.

**RO:** Nu confundați șuruburile similare.

A x 6

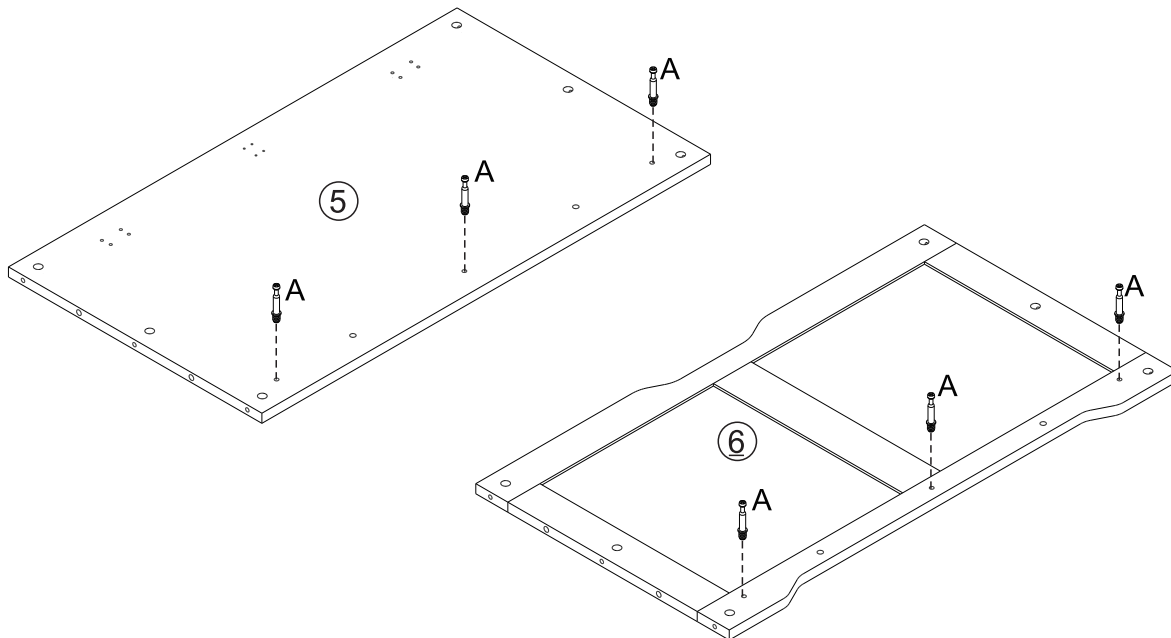
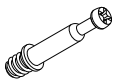

A x 16

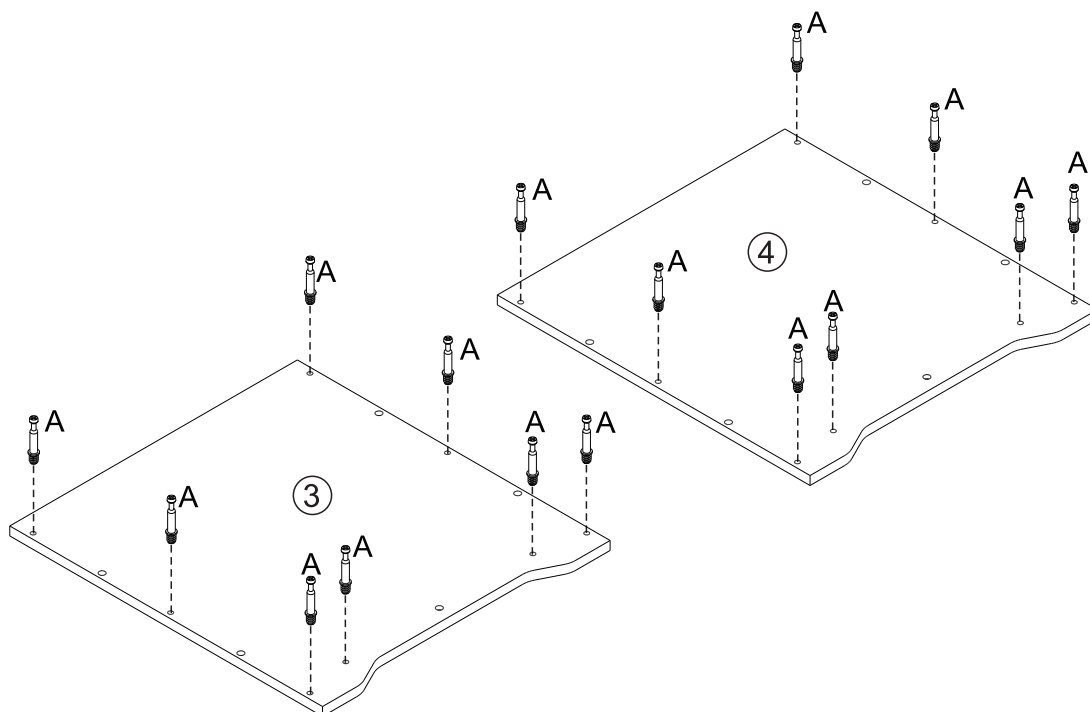
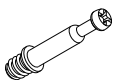

B x 3



D x 2

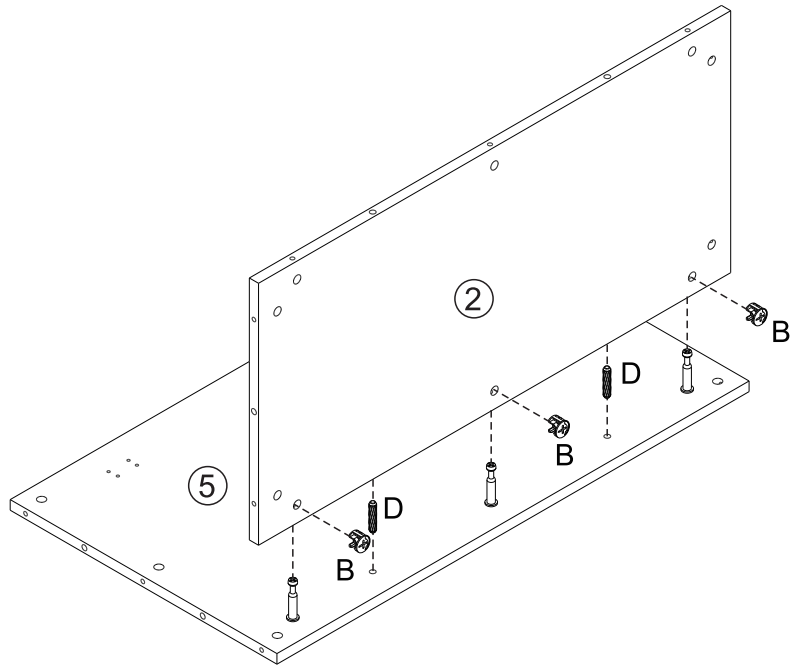

B x 3



D x 2

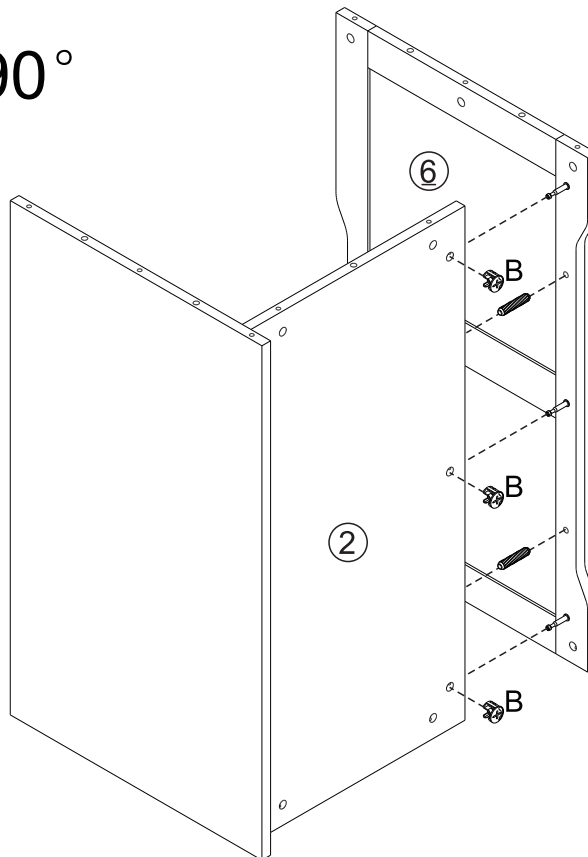

- B** x 16
- C** x 8
- D** x 2
- E** x 8

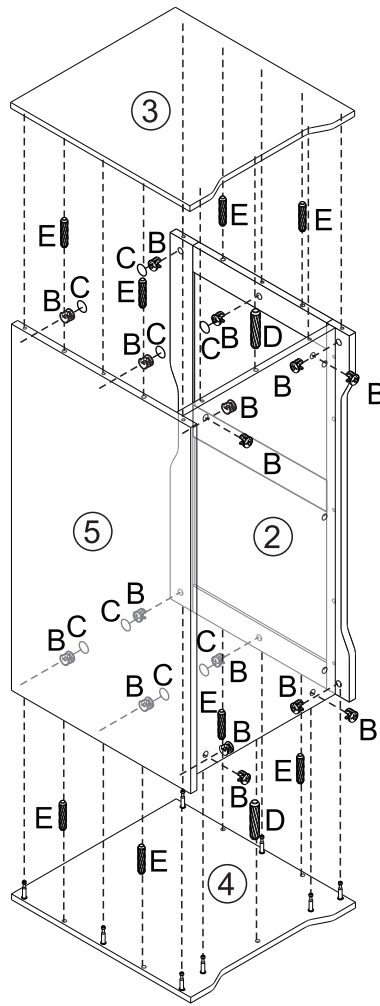
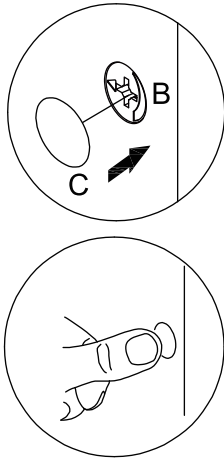

- J** x 4

90°

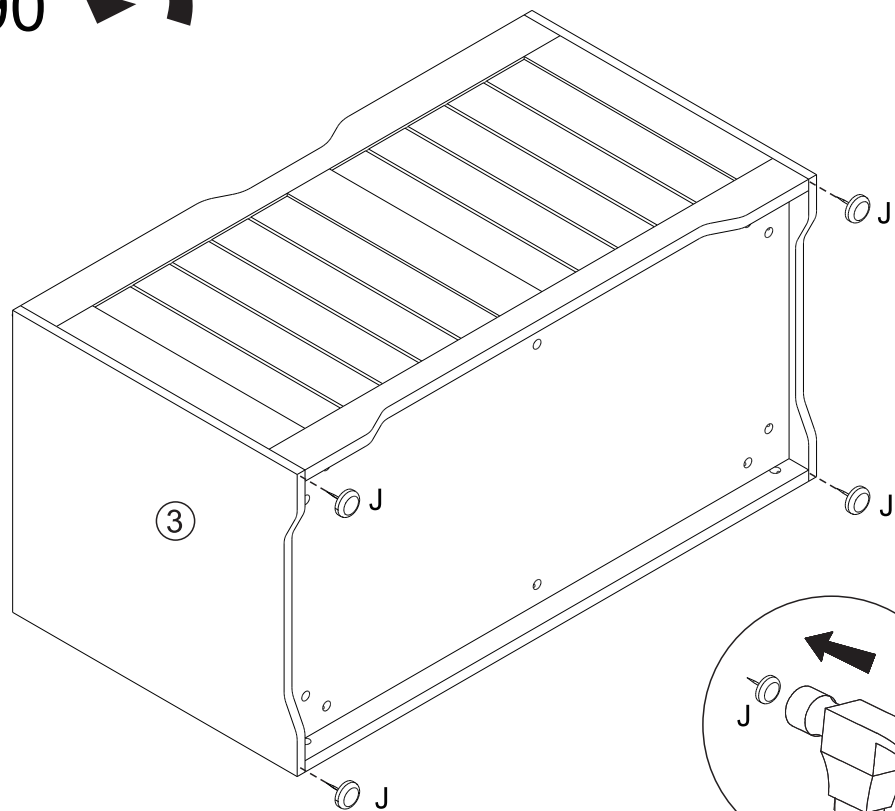

- F** x 8
- G** x 2
- H** x 1

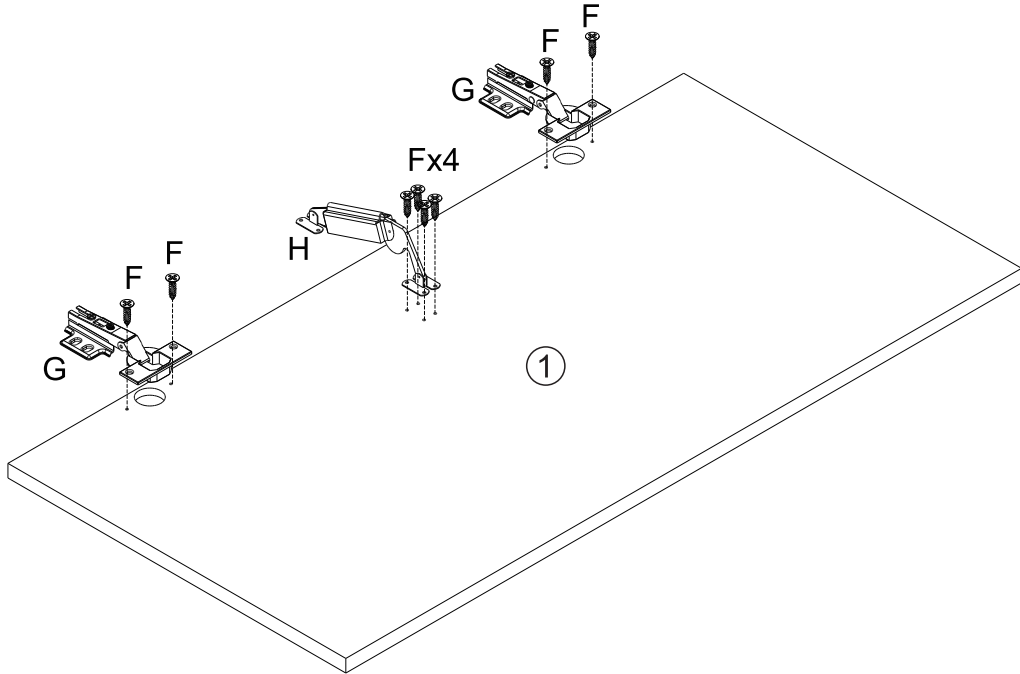

- F** x 12
- I** x 2

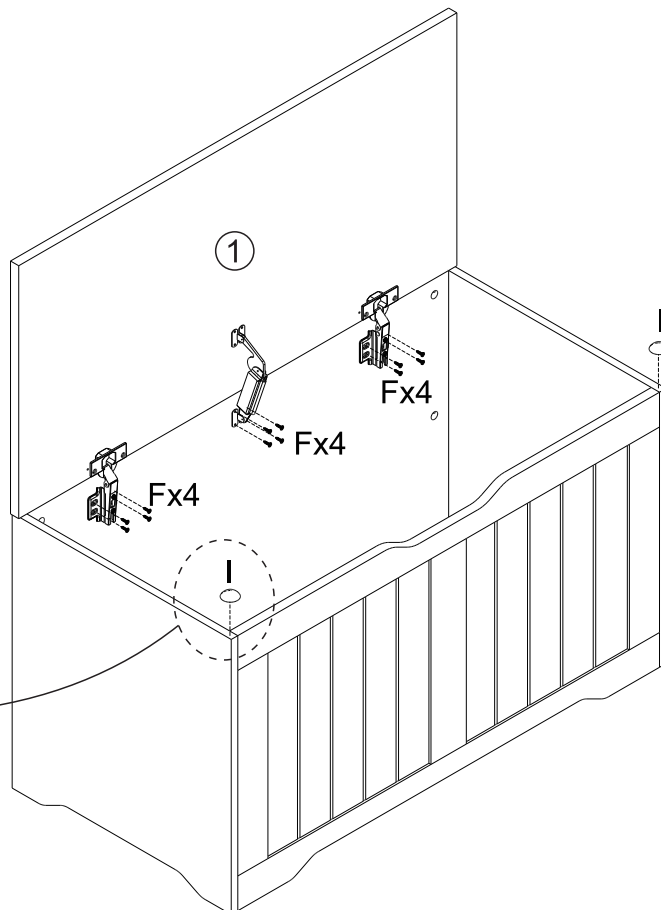

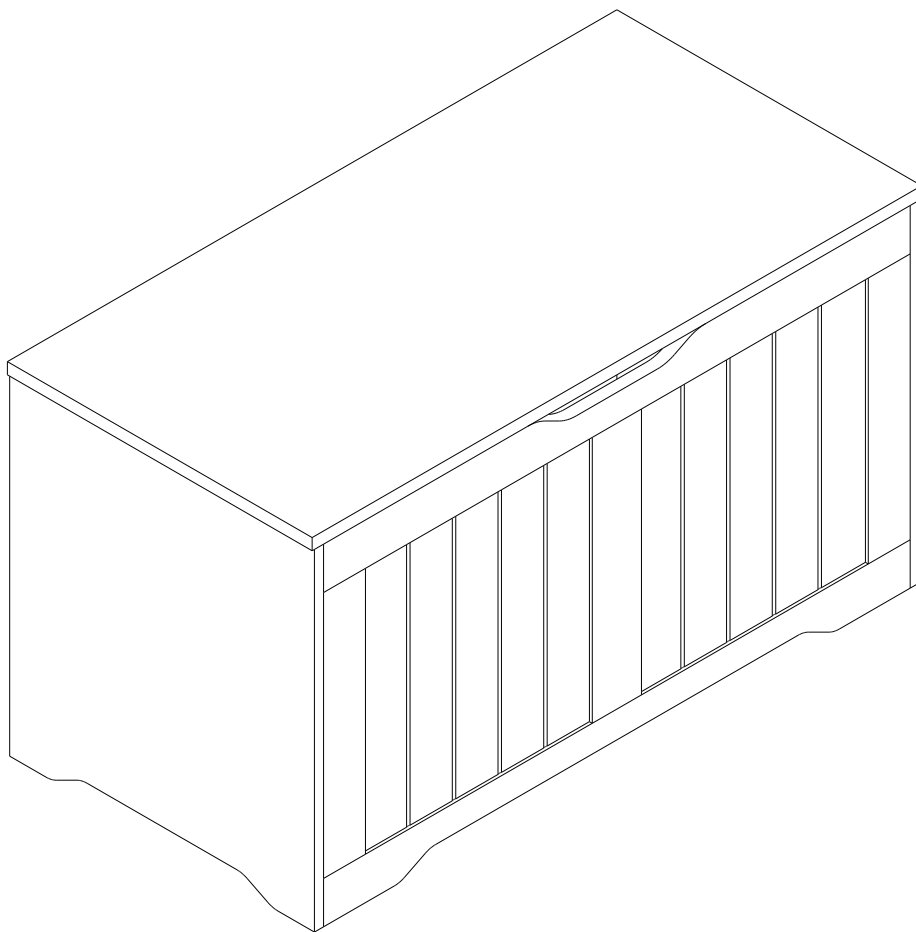

- 1
- 2
- 3
- 4
- 5



If you have any questions, please contact our customer care center, Our contact details are below:

**US**

 001-877-644-9366

 customerservice@aosom.com

Imported by Aosom LLC  
7777 Center Ave. Suite 430  
Huntington Beach, CA 92647-9998 USA  
MADE IN CHINA

Wenn Sie Fragen haben, wenden Sie sich bitte an unser Kundendienstzentrum, Unsere Kontaktdaten stehen unten:

**DE**

 +49 40 87408465

 service@aosom.de

ADRESSE DES IMPORTEURE/Hersteller/REP:  
MH Handel GmbH  
Wendenstraße 309  
D-20537 Hamburg  
Germany  
IN CHINA HERGESTELLT

If you have any questions, please contact our customer care center, Our contact details are below:

**CA**

 416-792-6088

 customerservice@aosom.ca

Imported by Aosom Canada Inc.  
7270 Woodbine Avenue, Unit 307, Markham,  
Ontario Canada L3R 4B9  
MADE IN CHINA

Si vous avez la moindre question, veuillez contacter notre centre d'assistance à la clientèle, Nos coordonnées sont les suivantes:

 416-792-6088

 customerservice@aosom.ca

Importé par Aosom Canada Inc.  
7270 Woodbine Avenue, unité 307,  
Markham, Ontario Canada L3R 4B9  
FABRIQUÉ EN CHINE

In caso di dubbio, si prega di contattare il nostro centro assistenza clienti, I nostri dettagli di contatto sono di seguito:

**IT**

 0039-0249471447

 clienti@aosom.it

IMPORTATO DA/Produttore/REP:  
AOSOM Italy srl  
Centro Direzionale Milanofiori  
Strada 1 Palazzo F1  
20057 Assago (MI)  
P.I.: 08567220960  
FATTO IN CINA

Si tiene alguna pregunta, comuníquese con nuestro Centro de Atención al Cliente, Nuestros datos de contacto son los siguientes:

**ES**

 0034-931294512

 atencioncliente@aosom.es

IMPORTADOR/Fabricante/REP:  
SPANISH AOSOM, S.L.  
C/ROC GROS, N°15.08550, ELS HOSTALETES DE  
BALENYÀ, SPAIN.  
B66295775  
HECHO EN CHINA

Se tiver alguma dúvida, por favor contacte o nosso Centro de Atendimento ao Cliente, Os nossos dados de contacto são os seguintes:

 0034-931294512

 info@aosom.pt.

IMPORTADOR/Fabricante/REP:  
SPANISH AOSOM, S.L.  
C.ROC GROS N.15, 08550. ELS HOSTALETES DE  
BALENYÀ  
FEITO NA CHINA

If you have any questions, please contact our customer care center, Our contact details are below:

**UK**

 0044-800-240-4004

 enquiries@mhstar.co.uk

IMPORTER ADDRESS:  
MH STAR UK Ltd  
1 Northampton Cross Logistics Park  
Northampton Cross Road  
Northampton  
NN4 9FH  
MADE IN CHINA

Si vous avez la moindre question, veuillez contacter notre centre d'assistance à la clientèle, Nos coordonnées sont les suivantes:

**FR**

 0033-1-84166106

 aosom@mhfrance.fr

Importé par/Fabricant/REP:  
MH FRANCE  
2 Rue Maurice Hartmann  
92130 Issy Les Moulineaux  
France  
FABRIQUÉ EN CHINE



**FR**

**DONNEZ  
OU  
RECYCLEZ**



ASSOCIATION

OU



LIVRAISON

OU



DÉCHÈTERIE

Adresses sur [quefairedemesdechets.fr](http://quefairedemesdechets.fr)