

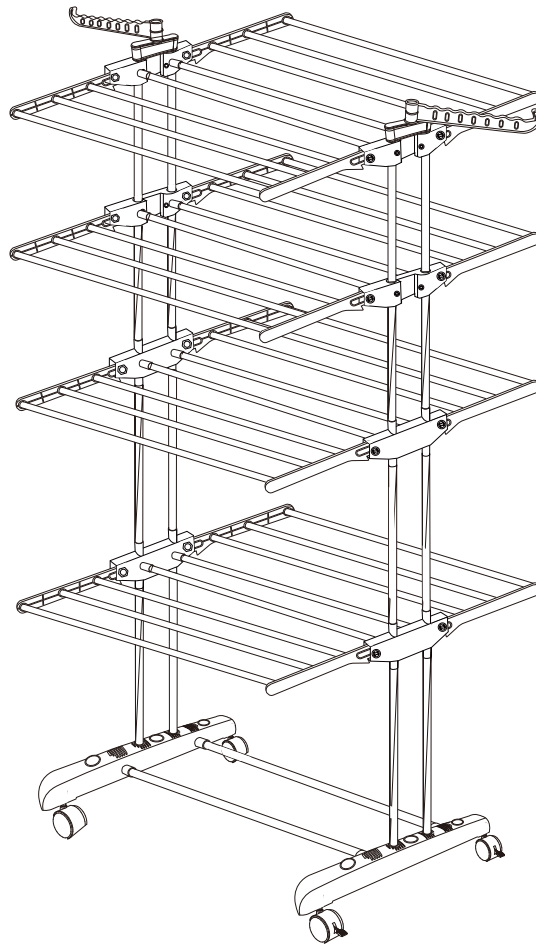

IN260300093V01

**850-390V00**



**12**  
STEPS

  
1 HR



**EN\_ IMPORTANT, RETAIN FOR FUTURE REFERENCE: READ CAREFULLY.**

**FR\_ IMPORTANT: A LIRE ATTENTIVEMENT ET À CONSERVER POUR CONSULTATION ULTÉRIEURE.**

**ES\_ IMPORTANTE, LEA Y GUARDE PARA FUTURAS REFERENCIAS.**

**PT\_ IMPORTANTE: LEIA ATENTAMENTE E GUARDE PARA CONSULTA FUTURA.**

**DE\_ WICHTIG! SORGFÄLTIG LESEN UND FÜR SPÄTER NACHSCHLAGEN AUFBEWAHREN.**

**IT\_ IMPORTANTE! CONSERVARE IL PRESENTE MANUALE PER FUTURO RIFERIMENTO E LEGGERLO ATTENTAMENTE.**

**RO\_ IMPORTANT: CITIȚI CU ATENȚIE ȘI PĂSTRAȚI PENTRU CONSULTARE VIITOARE.**

**PARTS**

**A** x 2



**B** x 2

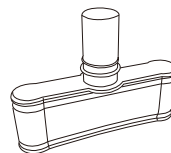

**C** x 4

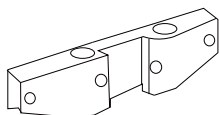

**D** x 4

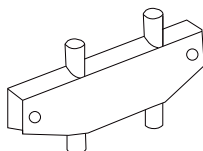

**E<sub>1</sub>** x 8

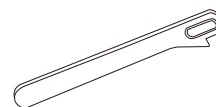

**E<sub>2</sub>** x 8

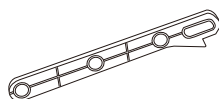

**F<sub>1</sub>** x 1



**F<sub>2</sub>** x 1



**G<sub>1</sub>** x 2

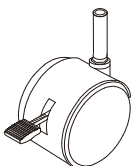

**G<sub>2</sub>** x 2

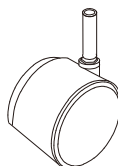

**H** x 24  
710x13mm

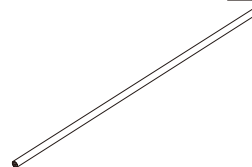

**J** x 2  
660x19mm

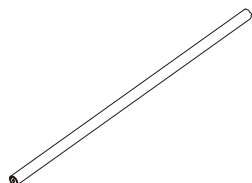

**K** x 8  
680x13mm

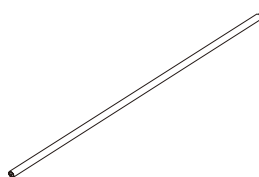

**M** x 12  
520x19mm

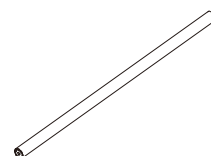

**HARDWARE**

**1** x 16  
M6x20

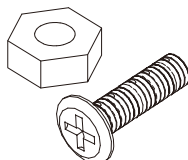

**2** x 8  
M6x30

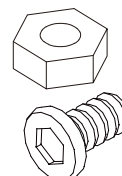

**F<sub>1</sub>** x 1**F<sub>2</sub>** x 1**G<sub>1</sub>** x 2**G<sub>2</sub>** x 2**01**

- EN\_ Install **G<sub>1</sub>** & **G<sub>2</sub>** part to part **F<sub>1</sub>** & **F<sub>2</sub>** .  
 FR\_ Installation **G<sub>1</sub>** & **G<sub>2</sub>** pièce par pièce **F<sub>1</sub>** & **F<sub>2</sub>** .  
 ES\_ Instalación **G<sub>1</sub>** & **G<sub>2</sub>** pieza por pieza **F<sub>1</sub>** & **F<sub>2</sub>** .  
 PT\_ Instalação **G<sub>1</sub>** & **G<sub>2</sub>** peça por peça **F<sub>1</sub>** & **F<sub>2</sub>** .  
 DE\_ Installieren **G<sub>1</sub>** & **G<sub>2</sub>** Teil für Teil **F<sub>1</sub>** & **F<sub>2</sub>** .  
 IT\_ Installa **G<sub>1</sub>** & **G<sub>2</sub>** da parte a parte **F<sub>1</sub>** & **F<sub>2</sub>** .  
 RO\_ Instalare **G<sub>1</sub>** & **G<sub>2</sub>** de la un component la altul **F<sub>1</sub>** & **F<sub>2</sub>** .

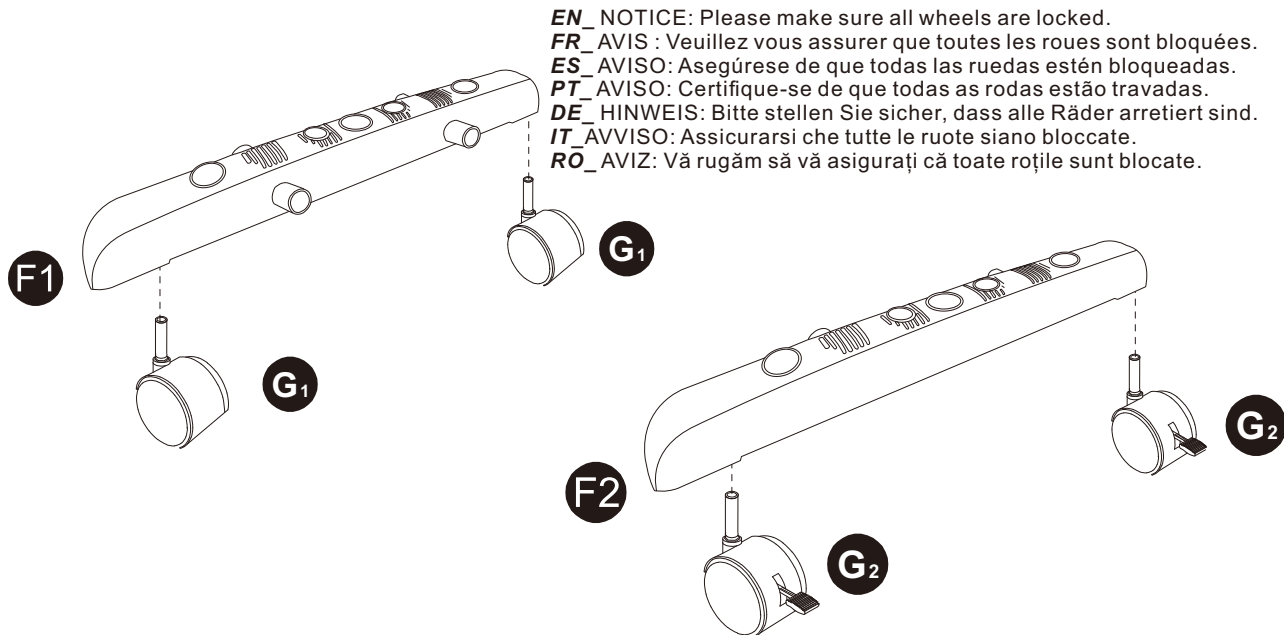
**J** x 2

660x19mm

**02**

- EN\_ Connect Part **F<sub>1</sub>** and **F<sub>2</sub>** with Part **J** .  
 FR\_ Reliez la pièce **F<sub>1</sub>** et **F<sub>2</sub>** à la pièce **J** .  
 ES\_ Conecta la pieza **F<sub>1</sub>** y **F<sub>2</sub>** con la pieza **J** .  
 PT\_ Ligue a peça **F<sub>1</sub>** e **F<sub>2</sub>** à peça **J** .  
 DE\_ Verbinde Teil **F<sub>1</sub>** und **F<sub>2</sub>** mit Teil **J** .  
 IT\_ Collega la parte **F<sub>1</sub>** e **F<sub>2</sub>** alla parte **J** .  
 RO\_ Conectează Piesa **F<sub>1</sub>** și **F<sub>2</sub>** cu Piesa **J** .

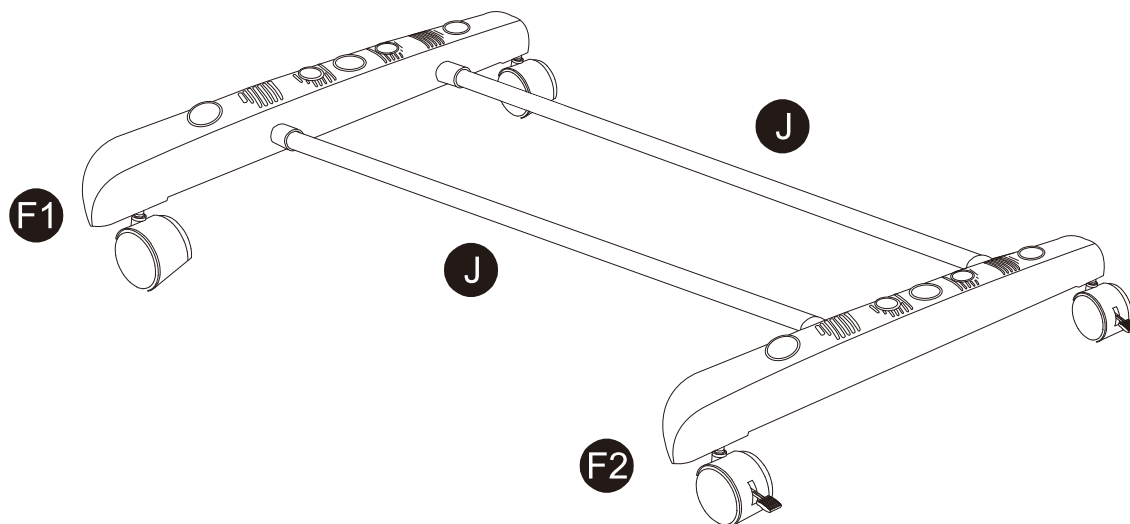

**C** x 4

**K** x 4

680x13mm

**03**

- EN\_** Connect all of part **C** with **K** part .
- FR\_** Reliez toutes les pièces **C** à **K** la pièce .
- ES\_** Une todas las piezas **C** con **K** la pieza .
- PT\_** Ligue toda a peça **C** à **K** peça .
- DE\_** Verbinde alle Teile **C** mit **K** Teil .
- IT\_** Collegare tutte le parti **C** con **K** la parte .
- RO\_** Conectați toate piesele **C** cu **K** piesa .

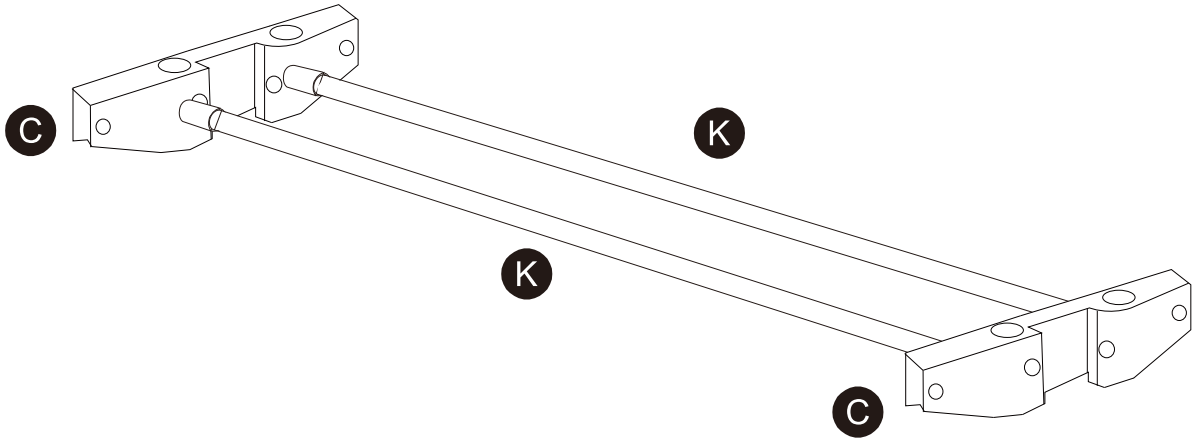

**x2**

**D** x 4

**K** x 4

680x13mm

**04**

- EN\_** Connect all of part **D** with **K** part .
- FR\_** Reliez toutes les pièces **D** à **K** la pièce .
- ES\_** Une todas las piezas **D** con **K** la pieza .
- PT\_** Ligue toda a peça **D** à **K** peça .
- DE\_** Verbinde alle Teile **D** mit **K** Teil .
- IT\_** Collegare tutte le parti **D** con **K** la parte .
- RO\_** Conectați toate piesele **D** cu **K** piesa .

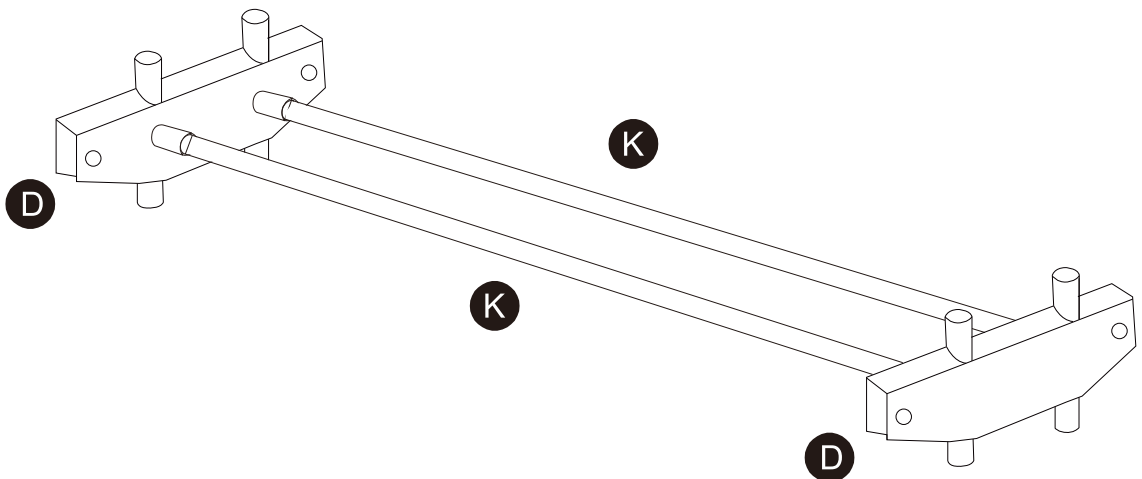

**x2**

**E<sub>1</sub>** x 8**E<sub>2</sub>** x 8**H** x24

710x13mm

**EN\_** Connect all of part **E<sub>1</sub>** & **E<sub>2</sub>** with **H** part .  
**FR\_** Reliez toutes les pièces **E<sub>1</sub>** & **E<sub>2</sub>** à **H** la pièce .  
**ES\_** Une todas las piezas **E<sub>1</sub>** & **E<sub>2</sub>** con **H** la pieza .  
**PT\_** Ligue toda a peça **E<sub>1</sub>** & **E<sub>2</sub>** à **H** peça .  
**DE\_** Verbinde alle Teile **E<sub>1</sub>** & **E<sub>2</sub>** mit **H** Teil .  
**IT\_** Collegare tutte le parti **E<sub>1</sub>** & **E<sub>2</sub>** con **H** la parte .  
**RO\_** Conectați toate piesele **E<sub>1</sub>** & **E<sub>2</sub>** cu **H** piesa .

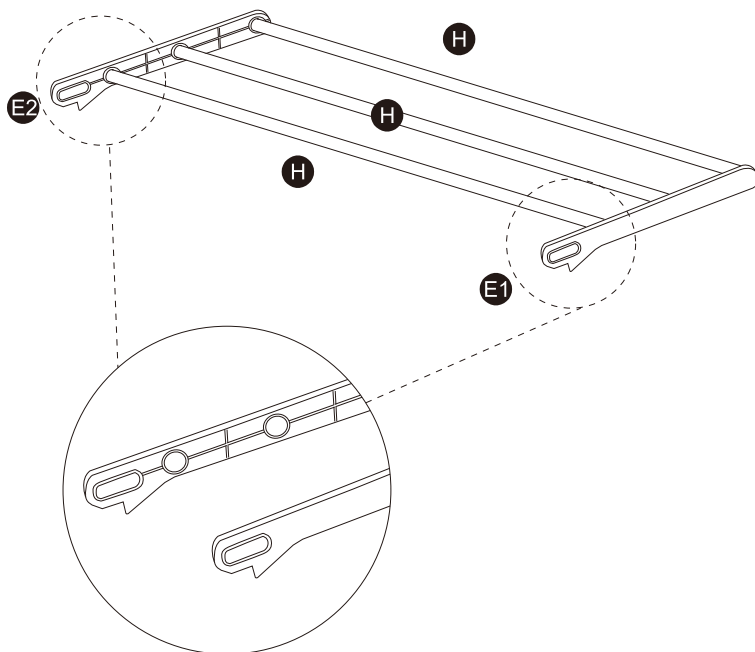
**05**

**EN\_ NOTICE:** Make sure **E<sub>1</sub>** and **E<sub>2</sub>** are mirror symmetrical while installing.

**FR\_ AVIS :** Assurez-vous que **E<sub>1</sub>** et **E<sub>2</sub>** soient symétriques par rapport à un axe de réflexion lors de l'installation.

**ES\_ AVISO:** Asegúrate de que **E<sub>1</sub>** y **E<sub>2</sub>** sean simétricos respecto a un eje durante la instalación.

**PT\_ AVISO:** Certifique-se de que **E<sub>1</sub>** e **E<sub>2</sub>** estão simétricos em relação ao eixo central durante a instalação.

**DE\_ HINWEIS:** Achten Sie bei der Installation darauf, dass **E<sub>1</sub>** und **E<sub>2</sub>** spiegelsymmetrisch sind.

**IT\_ AVVISO:** Assicurarsi che **E<sub>1</sub>** e **E<sub>2</sub>** siano simmetrici rispetto al centro durante l'installazione.

**RO\_ ATENȚIE:** Asigurați-vă că **E<sub>1</sub>** și **E<sub>2</sub>** sunt dispuse simetric în oglindă în timpul instalării.

**1** x 8

M6x20

**EN\_** Install 4 "SHELVES" that Step 5 assembled on part **C**, use part **1** to screw them.  
**FR\_** Installez les 4 « ÉTAGÈRES » assemblées à l'étape 5 sur la pièce **C**, puis utilisez la pièce **1** pour les visser.  
**ES\_** Instala las 4 « ESTANTERÍAS » que se montaron en el paso 5 en la pieza **C**; utiliza la pieza **1** para atornillarlas.  
**PT\_** Instale as 4 «prateleiras» montadas no Passo 5 na peça **C**; utilize a peça **1** para as aparafusar.  
**DE\_** Montieren Sie die 4 „Regalböden“, die in Schritt 5 an Teil **C** zusammengebaut wurden, und befestigen Sie sie mit Teil **1**.  
**IT\_** Installare i 4 "RIPIANI" assemblati al punto 5 sul componente **C**, utilizzando il componente **1** per avvitarli.  
**RO\_** Montați cele 4 „rafturi” asamblate la pasul 5 pe piesa **C** și folosiți piesa **1** pentru a le fixa cu șuruburi.

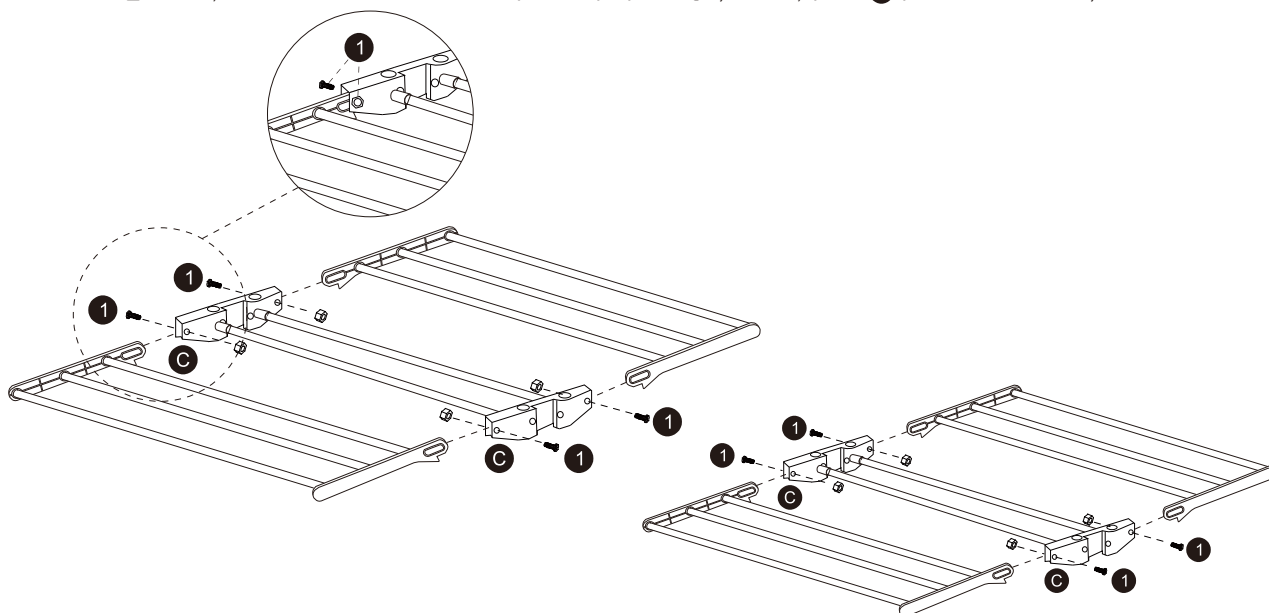
**06**

**1** x 8

M6x20

**07**

**EN\_** Install 4 "SHELVES" that Step 5 assembled on part **D**, use part **1** to screw them.

**FR\_** Installez les 4 « ÉTAGÈRES » assemblées à l'étape 5 sur la pièce **D**, puis utilisez la pièce **1** pour les visser.

**ES\_** Instala las 4 «ESTANTERÍAS» que se montaron en el paso 5 en la pieza **D**; utiliza la pieza **1** para atornillarlas.

**PT\_** Instale as 4 «prateleiras» montadas no Passo 5 na peça **D**; utilize a peça **1** para as aparafusar.

**DE\_** Montieren Sie die 4 „Regalböden“, die in Schritt 5 an Teil **D** zusammengebaut wurden, und befestigen Sie sie mit Teil **1**.

**IT\_** Installare i 4 "RIPIANI" assemblati al punto 5 sul componente **D**, utilizzando il componente **1** per avvitarli.

**RO\_** Montați cele 4 „rafturi” asamblate la pasul 5 pe piesa **D** și folosiți piesa **1** pentru a le fixa cu șuruburi.

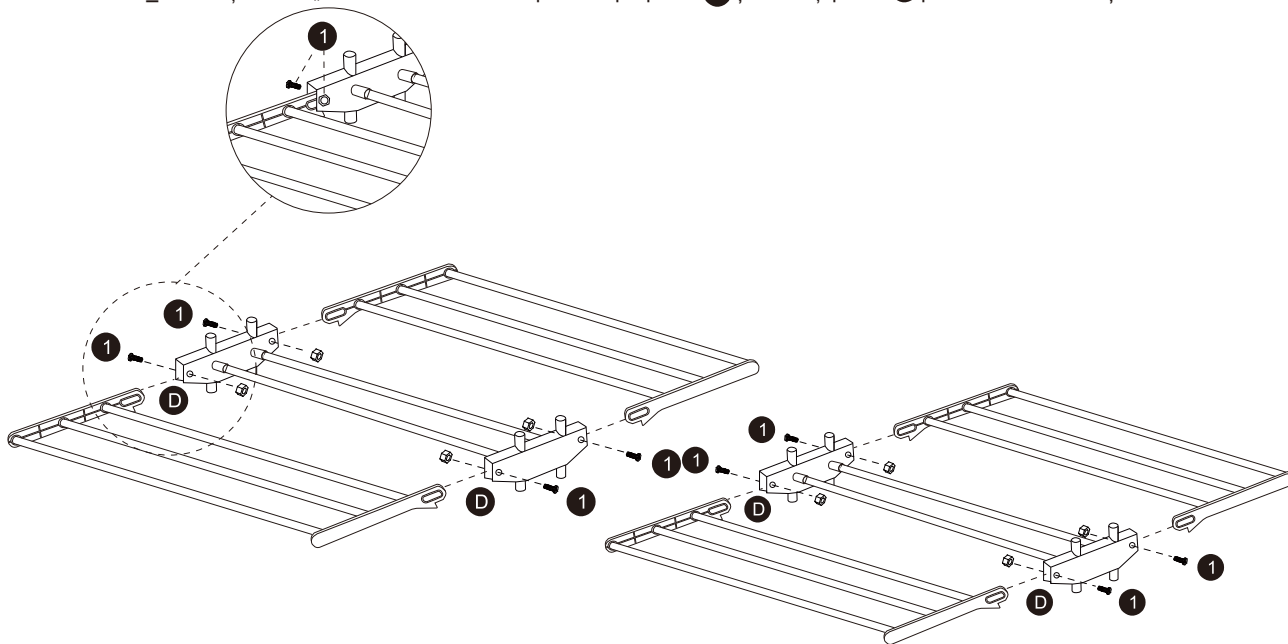

**M** x 4

520x19mm

**08**

**EN\_** Connect part **F1** & **F2** and part **D** with part **M**.

**FR\_** Relier la partie **F1** & **F2** et la partie **D** à la partie **M**.

**ES\_** Conecta la parte **F1** & **F2** y la parte **D** con la parte **M**.

**PT\_** Ligar a peça **F1** & **F2** e a peça **D** à peça **M**.

**DE\_** Verbinde Teil **F1** & **F2** und Teil **D** mit Teil **M**.

**IT\_** Collega la parte **F1** & **F2** e la parte **D** alla parte **M**.

**RO\_** Conectează piesa **F1** & **F2** și piesa **D** cu piesa **M**.

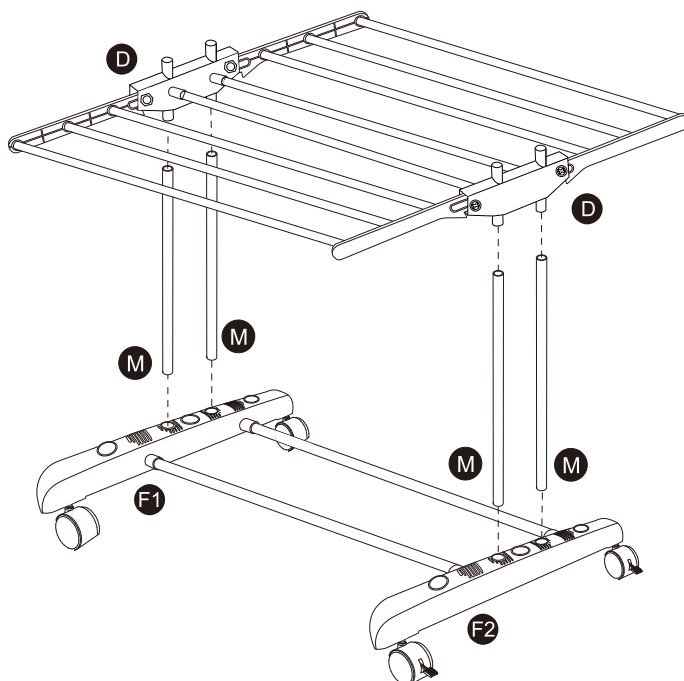

- EN\_** Connect part **D** and part **D** with part **M**.  
**FR\_** Relier la pièce **D** et la pièce **D** à la pièce **M**.  
**ES\_** Conecta la pieza **D** y la pieza **D** con la pieza **M**.  
**PT\_** Ligar a peça **D** e a peça **D** à peça **M**.  
**DE\_** Verbinde Teil **D** und Teil **D** mit Teil **M**.  
**IT\_** Collegare la parte **D** e la parte **D** con la parte **M**.  
**RÖ\_** Conectează piesa **D** și piesa **D** cu piesa **M**.

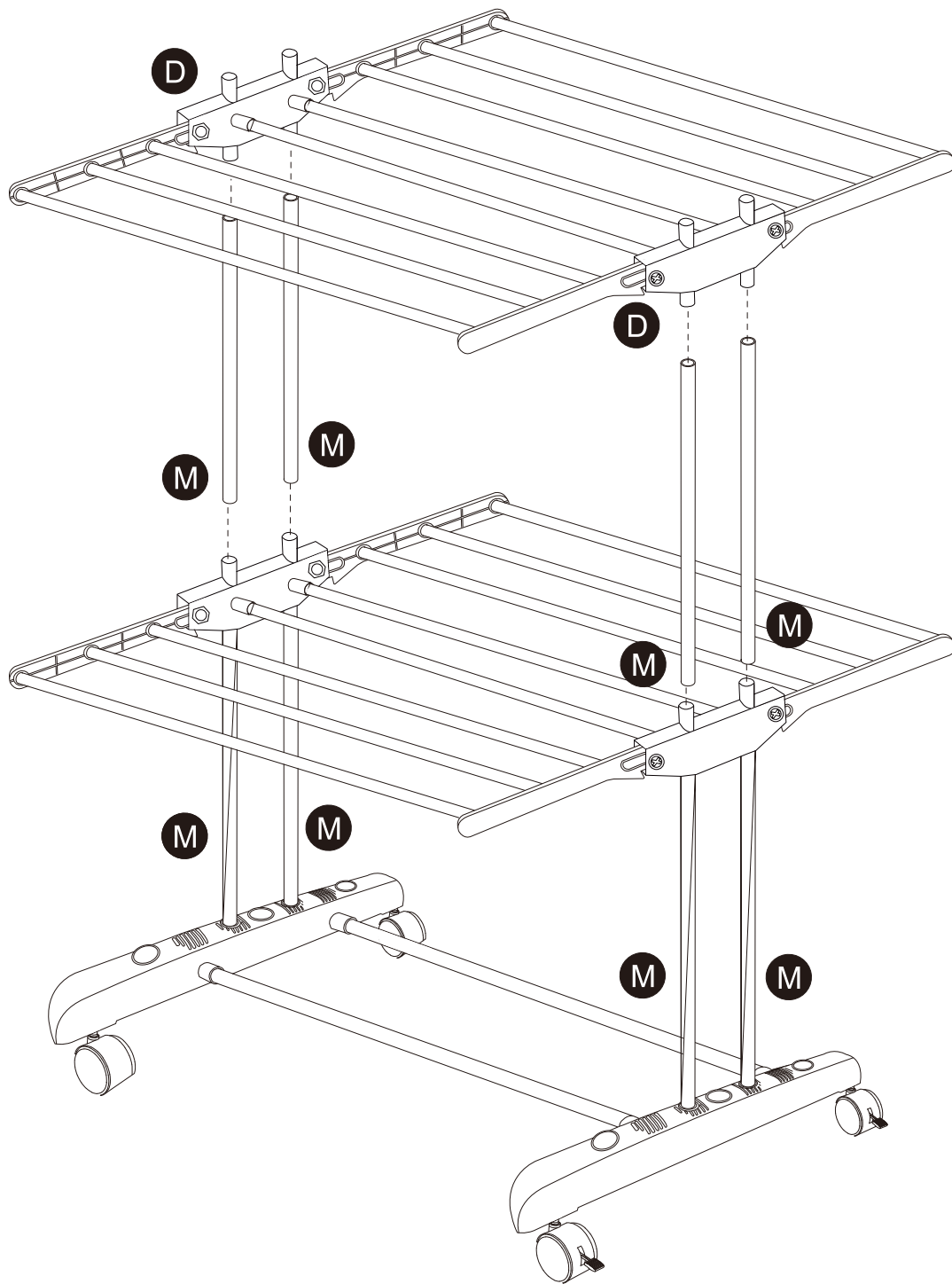

**M** x 4

520x19mm

**2** x 4

M6x30

**10**

**EN\_** Install part **M** on part **D**, then insert part **C** through the part **M**, use part **2** to screw them.

**FR\_** Installez la pièce **M** sur la pièce **D**, puis insérez la pièce **C** dans la pièce **M** et utilisez la pièce **2** pour les visser.

**ES\_** Instala la pieza **M** en la pieza **D**, luego introduce la pieza **C** a través de la pieza **M** y utiliza la pieza **2** para atornillarlas.

**PT\_** Instale a peça **M** na peça **D**, depois insira a peça **C** através da peça **M** e utilize a peça **2** para as aparafusar.

**DE\_** Setzen Sie Teil **M** auf Teil **D**, führen Sie dann Teil **C** durch Teil **M** und schrauben Sie beide Teile mit Teil **2** zusammen.

**IT\_** Installare il pezzo **M** sul pezzo **D**, quindi inserire il pezzo **C** attraverso il pezzo **M** e utilizzare il pezzo **2** per avvitarli.

**RO\_** Instalați piesa **M** pe piesa **D**, apoi introduceți piesa **C** prin piesa **M** și folosiți piesa **2** pentru a le înșuruba.

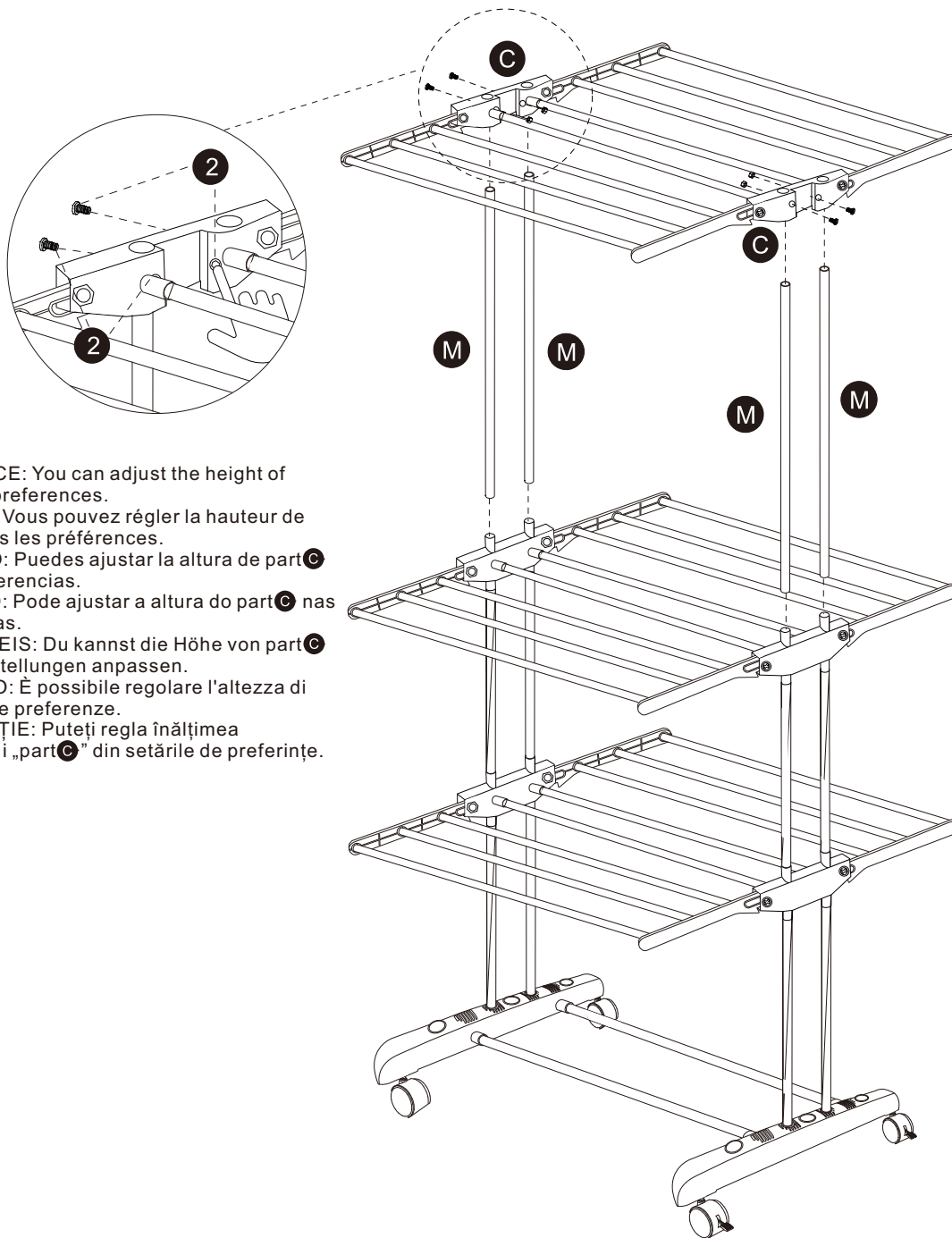

**EN\_ NOTICE:** You can adjust the height of part **C** by preferences.

**FR\_ AVIS :** Vous pouvez régler la hauteur de part **C** dans les préférences.

**ES\_ AVISO:** Puedes ajustar la altura de part **C** en las preferencias.

**PT\_ AVISO:** Pode ajustar a altura do part **C** nas preferências.

**DE\_ HINWEIS:** Du kannst die Höhe von part **C** in den Einstellungen anpassen.

**IT\_ AVVISO:** È possibile regolare l'altezza di part **C** dalle preferenze.

**RO\_ ATENȚIE:** Puteți regla înălțimea elementului „part **C**” din setările de preferințe.

- EN\_** Install part **C** on the top of part **M**, use part **2** to screw them.  
**FR\_** Placez la pièce **C** sur la pièce **M**, puis utilisez la pièce **2** pour les visser ensemble.  
**ES\_** Coloca la pieza **C** encima de la pieza **M**, y utiliza la pieza **2** para atornillarlas.  
**PT\_** Coloque a peça **C** em cima da peça **M**, e use a peça **2** para as aparafusar.  
**DE\_** Setzen Sie Teil **C** auf Teil **M**, und schrauben Sie sie mit Teil **2** zusammen.  
**IT\_** Posizionare il pezzo **C** sopra il pezzo **M**, quindi avvitarli insieme utilizzando il pezzo **2**.  
**RÖ\_** Așezați piesa **C** deasupra piesei **M**, apoi folosiți piesa **2** pentru a le înșuruba.

- EN\_ NOTICE:** While installing part **C**, part **M** needs to go through part **C** a bit for following installation.  
**FR\_ AVIS :** Lors de l'installation de la partie **C**, il est **M** nécessaire de passer brièvement par la partie **C** pour poursuivre l'installation.  
**ES\_ AVISO:** Al instalar la pieza **C**, es **M** necesario pasar por la pieza **C** para continuar con la instalación.  
**PT\_ AVISO:** Durante a instalação da parte **C**, a parte **M** precisa de passar um pouco pela parte **C** para que a instalação possa prosseguir.  
**DE\_ HINWEIS:** Bei der Installation von Teil **C** muss Teil **M** für die weitere Installation kurz durch Teil **C** geführt werden.  
**IT\_ AVVISO:** Durante l'installazione di parte **C**, è **M** necessario eseguire prima parte **C** per poter procedere con l'installazione successiva.  
**RO\_ ATENȚIE:** În timpul instalării componentei **C**, este necesar ca aceasta să treacă puțin prin **M** componenta **C** pentru a continua instalarea.

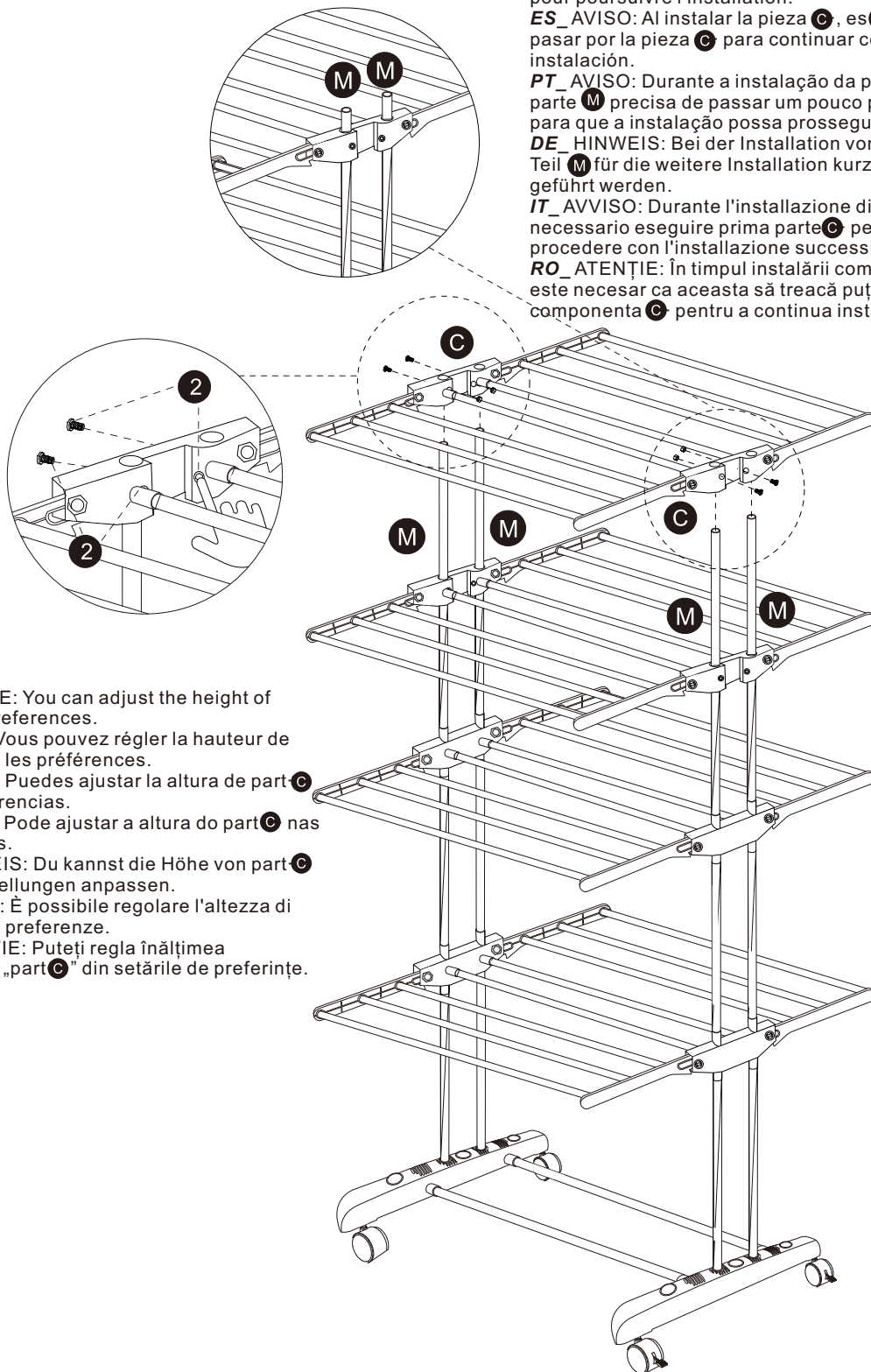

- EN\_ NOTICE:** You can adjust the height of part **C** by preferences.  
**FR\_ AVIS :** Vous pouvez régler la hauteur de part **C** dans les préférences.  
**ES\_ AVISO:** Puedes ajustar la altura de part **C** en las preferencias.  
**PT\_ AVISO:** Pode ajustar a altura do part **C** nas preferências.  
**DE\_ HINWEIS:** Du kannst die Höhe von part **C** in den Einstellungen anpassen.  
**IT\_ AVVISO:** È possibile regolare l'altezza di part **C** dalle preferenze.  
**RO\_ ATENȚIE:** Puteți regla înălțimea elementului „part **C**” din setările de preferințe.

- EN\_ Install part **B** on the prominent of part **M**, then install part **A** on the top of part **B**.
- FR\_ Installez la pièce **B** sur la partie saillante de la pièce **M**, puis installez la pièce **A** sur le dessus de la pièce **B**.
- ES\_ Instala la pieza **B** en la parte saliente de la pieza **M**, y luego instala la pieza **A** en la parte superior de la pieza **B**.
- PT\_ Instale a peça **B** na parte saliente da peça **M**, e depois instale a peça **A** na parte superior da peça **B**.
- DE\_ Montieren Sie Teil **B** auf der Vorderseite von Teil **M**, und montieren Sie anschließend Teil **A** auf der Oberseite von Teil **B**.
- IT\_ Montare il componente **B** sulla parte sporgente del componente **M**, quindi montare il componente **A** sulla parte superiore del componente **B**.
- RO\_ Montați piesa **B** pe partea proeminentă a piesei **M**, apoi montați piesa **A** deasupra piesei **B**.

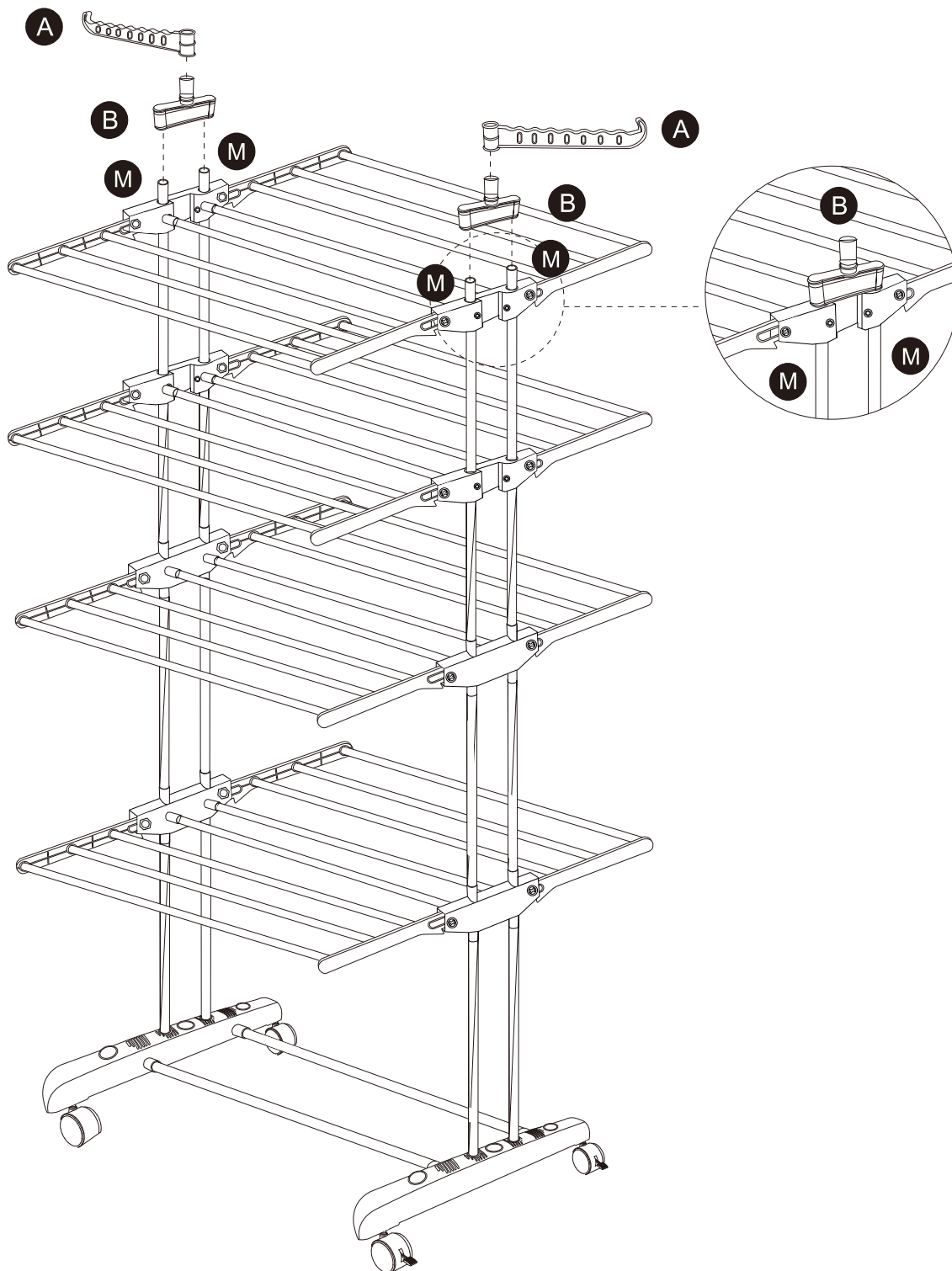

If you have any questions, please contact our customer care center, Our contact details are below:

**US**

 001-877-644-9366

 customerservice@aosom.com

Imported by Aosom LLC  
7777 Center Ave. Suite 430  
Huntington Beach, CA 92647-9998 USA  
MADE IN CHINA

If you have any questions, please contact our customer care center, Our contact details are below:

**CA**

 416-792-6088

 customerservice@aosom.ca

Imported by Aosom Canada Inc.  
7270 Woodbine Avenue, Unit 307, Markham,  
Ontario Canada L3R 4B9  
MADE IN CHINA

Si vous avez la moindre question, veuillez contacter notre centre d'assistance à la clientèle, Nos coordonnées sont les suivantes:

 416-792-6088

 customerservice@aosom.ca

Importé par Aosom Canada Inc.  
7270 Woodbine Avenue, unité 307,  
Markham, Ontario Canada L3R 4B9  
FABRIQUÉ EN CHINE

If you have any questions, please contact our customer care center, Our contact details are below:

**UK**

 0044-800-240-4004

 enquiries@mhstar.co.uk

IMPORTER ADDRESS:  
MH STAR UK Ltd  
1 Northampton Cross Logistics Park  
Northampton Cross Road  
Northampton  
NN4 9FH  
MADE IN CHINA

Si vous avez la moindre question, veuillez contacter notre centre d'assistance à la clientèle, Nos coordonnées sont les suivantes:

 0033-1-84166106

 aosom@mhfrance.fr

Importé par/Fabricant/REP:  
MH FRANCE  
2 Rue Maurice Hartmann  
92130 Issy Les Moulineaux  
France  
FABRIQUÉ EN CHINE

Si tiene alguna pregunta, comuníquese con nuestro Centro de Atención al Cliente, Nuestros datos de contacto son los siguientes:

**ES**

 0034-931294512

 atencioncliente@aosom.es

IMPORTADOR/Fabricante/REP:  
SPANISH AOSOM, S.L.  
C/ROC GROS,Nº15.08550, ELS HOSTALET DE  
BALENYÀ, SPAIN.  
B66295775  
HECHO EN CHINA

Se tiver alguma dúvida, por favor contacte o nosso Centro de Atendimento ao Cliente, Os nossos dados de contacto são os seguintes:

 0034-931294512

 info@aosom.pt.

IMPORTADOR/Fabricante/REP:  
SPANISH AOSOM, S.L.  
C.ROC GROS N.15, 08550. ELS HOSTALET DE  
BALENYÀ  
FEITO NA CHINA

In caso di dubbio, si prega di contattare il nostro centro assistenza clienti, I nostri dettagli di contatto sono di seguito:

**IT**

 0039-0249471447

 clienti@aosom.it

IMPORTATO DA/Produttore/REP:  
AOSOM Italy srl  
Centro Direzionale Milanofiori  
Strada 1 Palazzo F1  
20057 Assago (MI)  
P.I.: 08567220960  
FATTO IN CINA

Wenn Sie Fragen haben, wenden Sie sich bitte an unser Kundendienstzentrum, Unsere Kontaktdaten stehen unten:

**DE**

 0049-0(40)-87408465

 service@aosom.de

ADRESSE DES IMPORTEURE/Hersteller/REP:  
MH Handel GmbH  
Wendenstraße 309  
D-20537 Hamburg  
Germany  
IN CHINA HERGESTELLT

Si vous avez la moindre question, veuillez contacter notre centre d'assistance à la clientèle, Nos coordonnées sont les suivantes:

**FR**

 0033-1-84166106

 aosom@mhfrance.fr

Importé par/Fabricant/REP:  
MH FRANCE  
2 Rue Maurice Hartmann  
92130 Issy Les Moulineaux  
France  
FABRIQUÉ EN CHINE



**FR**

**DONNEZ  
OU  
RECYCLEZ**



ASSOCIATION

OU



LIVRAISON

OU



DÉCHÈTERIE

Adresses sur [quefairedemesdechets.fr](http://quefairedemesdechets.fr)