**4**

STEPS



1 HR



EN_ IMPORTANT, RETAIN FOR FUTURE REFERENCE: READ CAREFULLY.

FR_ IMPORTANT: A LIRE ATTENTIVEMENT ET À CONSERVER POUR CONSULTATION ULTÉRIEURE.

ES_ IMPORTANTE, LEA Y GUARDE PARA FUTURAS REFERENCIAS.

PT_ IMPORTANTE: LEIA ATENTAMENTE E GUARDE PARA CONSULTA FUTURA.

DE_ WICHTIG! SORGFÄLTIG LESEN UND FÜR SPÄTER NACHSCHLAGEN AUFBEWAHREN.

IT_ IMPORTANTE! CONSERVARE IL PRESENTE MANUALE PER FUTURO RIFERIMENTO E LEGGERLO ATTENTAMENTE.

RO_ IMPORTANT: CITIȚI CU ATENȚIE ȘI PĂSTRAȚI PENTRU CONSULTARE VIITOARE.

EN

1. Pay attention to the sharp edge of some parts.
2. Wearing safety gloves, eye protection and long sleeves during the assembly to prevent injury.
3. Children and pets are not allowed entering into the construction site.

**FR**

1. Faites attention au bord tranchant de certaines parties.
2. Porter des gants de protection, des lunettes de protection et des manches longues pendant le montage pour éviter les blessures.
3. Les enfants et les animaux domestiques ne sont pas admis sur le chantier de construction.

ES

1. Preste atención al borde afilado de algunas partes.
2. Use guantes de seguridad, protección ocular y mangas largas durante el montaje para evitar lesiones.
3. Los niños y las mascotas no pueden ingresar al sitio de construcción.

PT

1. Prestar atenção à aresta afiada de algumas peças.
2. Usar luvas de segurança, protecção dos olhos e mangas compridas durante a montagem para evitar ferimentos.
3. Não é permitida a entrada de crianças e animais de estimação no abrigo durante a construção.

DE

1. Achten Sie auf die scharfe Kante für einige Teile.
2. Tragen Sie die Schutzhandschuhen, Augenschutz und langen Ärmeln bei der Montage zur Vermeidung von Verletzungen.
3. Die Kinder und Haustiere dürfen nicht auf die Baustelle betreten.

IT

1. Prestare attenzione al bordo tagliente di alcune parti.
2. Indossare guanti di sicurezza, occhiali protettivi e maniche lunghe durante l'assemblaggio per evitare lesioni.
3. Ai bambini e agli animali domestici non è consentito entrare nel cantiere.

PL

1. Należy zwrócić uwagę na ostre krawędzie niektórych części;
2. Podczas montażu należy nosić rękawice ochronne, okulary ochronne i długie rękawy, aby zapobiec obrażeniom;
3. Dzieci i zwierzęta nie mają wstępu na plac budowy;

RO

1. Acordați atenție marginilor ascuțite ale unor piese;
2. Purtați mănuși de protecție, ochelari de protecție și mâneci lungi în timpul asamblării pentru a preveni rănirea;
3. Copiii și animalele de companie nu au voie să intre pe șantier;

PARTS

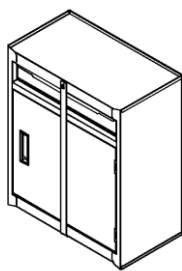

1 x 1

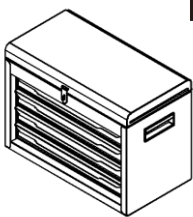

2 x 1

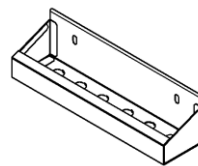

3 x 1



4 x 1

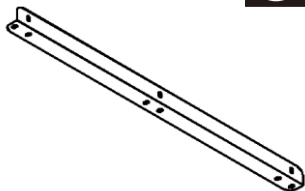

5 x 4

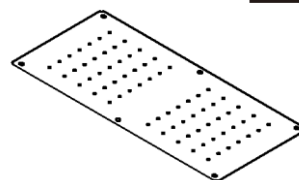

6 x 1

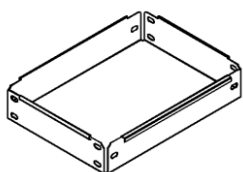

7 x 1

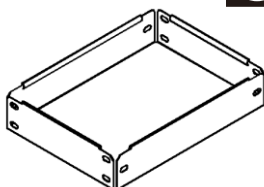

8 x 1

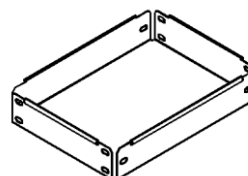

9 x 1



10 x 2

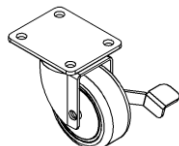

11 x 2

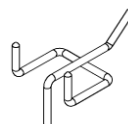

12 x 4

HARDWARE



A x18
M6*12



B x36
M6*10



C x52

10 x 2

11 x 2

A x16
M6*12

C x16

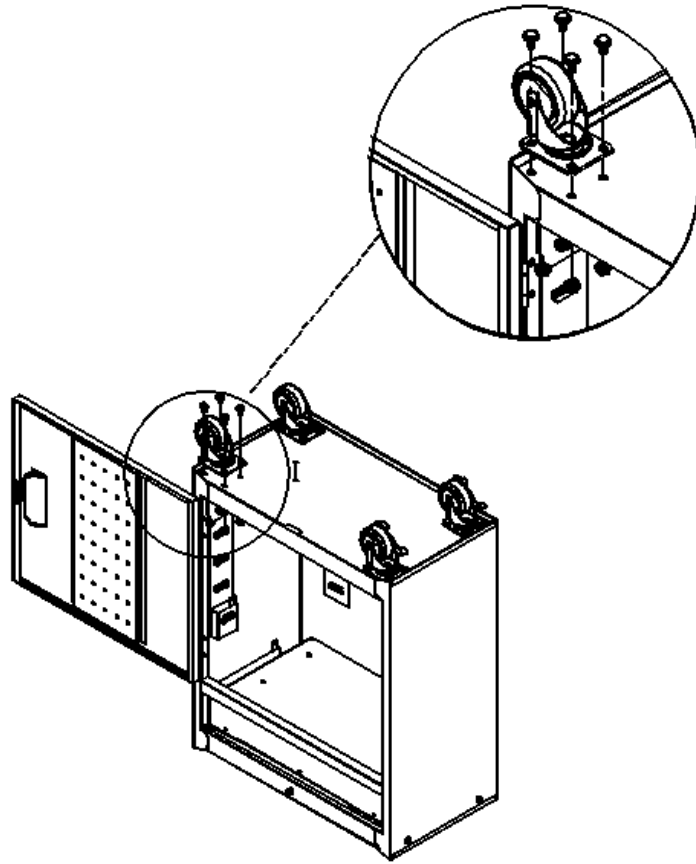

3 x 1

A x 2
M6*12

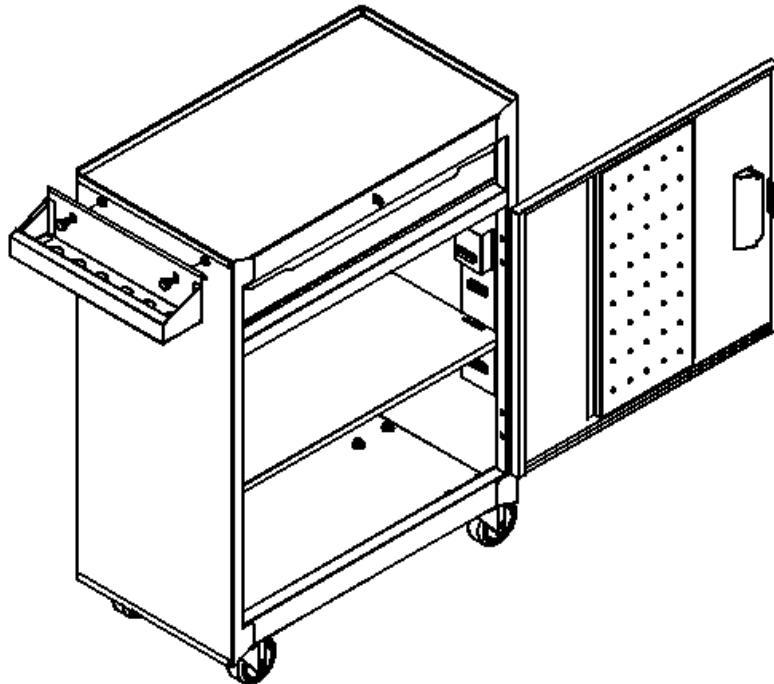

⑤ x 4

⑥ x 1

⑦ x 1

⑧ x 1

⑨ x 1

⑫ x 4

B x36
M6*10

C x36

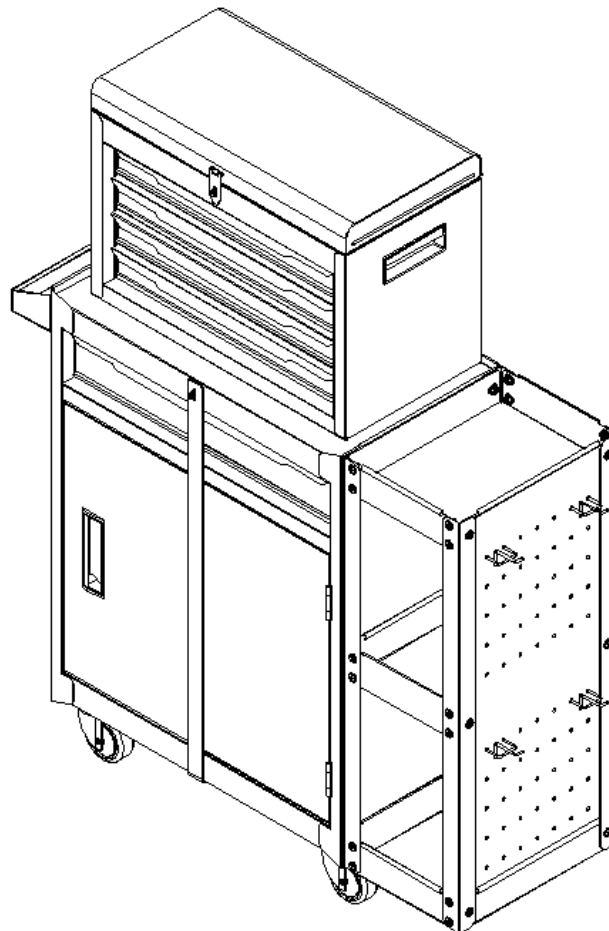
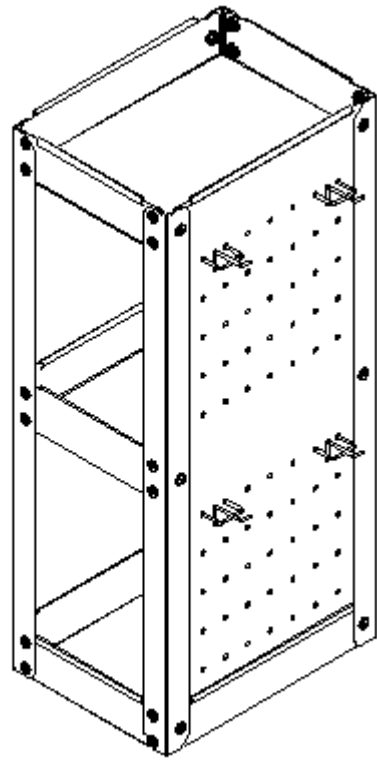
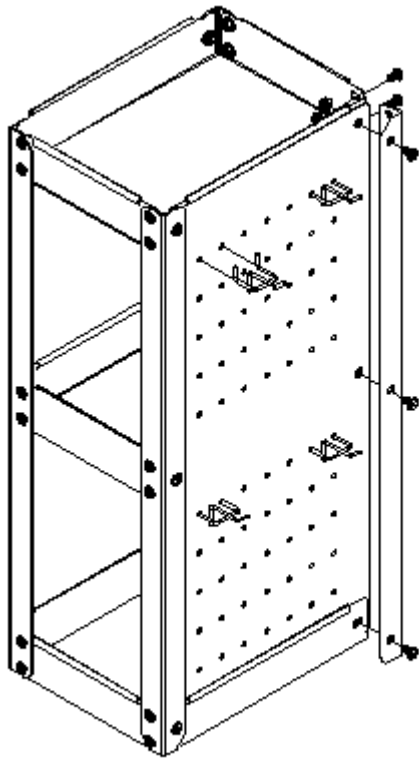

If you have any questions, please contact our customer care center, Our contact details are below:

US

 001-877-644-9366

 customerservice@aosom.com

Imported by Aosom LLC
7777 Center Ave. Suite 430
Huntington Beach, CA 92647-9998 USA

If you have any questions, please contact our customer care center, Our contact details are below:

CA

 416-792-6088

 customerservice@aosom.ca

Imported by Aosom Canada Inc.
7270 Woodbine Avenue, Unit 307, Markham,
Ontario Canada L3R 4B9
MADE IN CHINA

Si vous avez la moindre question, veuillez contacter notre centre d'assistance à la clientèle, Nos coordonnées sont les suivantes:

 416-792-6088

 customerservice@aosom.ca

Importé par Aosom Canada Inc.
7270 Woodbine Avenue, unité 307,
Markham, Ontario Canada L3R 4B9
FABRIQUÉ EN CHINE

Si tiene alguna pregunta, comuníquese con nuestro Centro de Atención al Cliente, Nuestros datos de contacto son los siguientes:

ES

 0034-931294512

 atencioncliente@aosom.es

IMPORTADOR/Fabricante/REP:
SPANISH AOSOM, S.L.
C/ROC GROS,Nº15.08550, ELS HOSTALETS DE
BALENYÀ, SPAIN.
B66295775
HECHO EN CHINA

Se tiver alguma dúvida, por favor contacte o nosso Centro de Atendimento ao Cliente, Os nossos dados de contacto são os seguintes:

 0034-931294512

 info@aosom.pt.

IMPORTADOR/Fabricante/REP:
SPANISH AOSOM, S.L.
C.ROC GROS N.15, 08550. ELS HOSTALETS DE
BALENYÀ
FEITO NA CHINA

In caso di dubbio, si prega di contattare il nostro centro assistenza clienti, I nostri dettagli di contatto sono di seguito:

IT

 0039-0249471447

 clienti@aosom.it

IMPORTATO DA/Produttore/REP:
AOSOM Italy srl
Centro Direzionale Milanofiori
Strada 1 Palazzo F1
20057 Assago (MI)
P.I.: 08567220960
FATTO IN CINA

If you have any questions, please contact our customer care center, Our contact details are below:

UK

 0044-800-240-4004

 enquiries@mhstar.co.uk

IMPORTER ADDRESS:
MH STAR UK Ltd
1 Northampton Cross Logistics Park
Northampton Cross Road
Northampton
NN4 9FH
MADE IN CHINA

Wenn Sie Fragen haben, wenden Sie sich bitte an unser Kundendienstzentrum, Unsere Kontaktdaten stehen unten:

DE

 0049-0(40)-87408465

 service@aosom.de

ADRESSE DES IMPORTEURE/Hersteller/REP:
MH Handel GmbH
Wendenstraße 309
D-20537 Hamburg
Germany
IN CHINA HERGESTELLT

Si vous avez la moindre question, veuillez contacter notre centre d'assistance à la clientèle, Nos coordonnées sont les suivantes:

FR

 0033-1-84166106

 aosom@mhfrance.fr

Importé par/Fabricant/REP:
MH FRANCE
2 Rue Maurice Hartmann
92130 Issy Les Moulineaux
France
FABRIQUÉ EN CHINE



FR

**DONNEZ
OU
RECYCLEZ**



OU



OU



ASSOCIATION

LIVRAISON

DÉCHÈTERIE

Adresses sur quefairedemesdechets.fr