

EN_IMPORTANT, RETAIN FOR FUTURE REFERENCE: READ CAREFULLY.

FR_IMPORTANT: A LIRE ATTENTIVEMENT ET A CONSERVER POUR VOUS Y REFERRER ULTERIEUREMENT

ES_IMPORTANTE, LEA DETENIDAMENTE Y GUARDE PARA FUTURAS REFERENCIAS.

PT_IMPORTANTE, GARDE PARA FUTURA REFERÊNCIA, LEIA ATENTAMENTE.

DE_WICHTIG! SORFGFÄLTIG LESEN UND FÜR SPÄTERES NACHSCHLAGEN AUFBEWAHREN.

IT_IMPORTANTE, LEGGERE E CONSERVARE QUESTO MANUALE D'ISTRUZIONE PER UN USO FUTURO.

RO_IMPORTANT, DE PĂSTRAT PENTRU REFERINȚE VIITOARE: CITIȚI CU ATENȚIE.

IMPORTANT/ATTENTION/ADVERTENCIA/AVISO /ACHTUNG/ATTENZIONE/IMPORTANT



EN: We recommend 2 or more people to install.
FR: Nous recommandons 2 personnes ou plus pour l'installation.
ES: Recomendamos a 2 personas o más para la instalación.
PT: Recomendamos 2 ou mais pessoas para a instalação.
DE: Wir empfehlen 2 oder mehr Personen für die Montage.
IT: Si consiglia 2 o più persone per l'installazione.
RO: Recomandăm instalarea de către 1 sau mai multe persoane.



EN: Place all parts on a clean, flat surface to avoid damage.
FR: Posez toutes les pièces sur une surface propre et plane pour éviter tout dommage.
ES: Coloque todas las piezas sobre una superficie limpia y plana para evitar daños.
PT: Coloque todas as peças sobre uma superfície limpa e plana para evitar danos.
DE: Legen Sie alle Teile auf eine saubere, ebene Fläche, um Beschädigungen zu vermeiden.
IT: Posizionare tutti i componenti su una superficie pulita e piana per evitare danni.
RO: Așezați toate piesele pe o suprafață curată și plană pentru a evita deteriorarea.

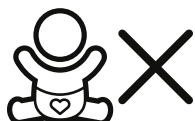

EN: Not intended for use by children.
FR: Ne pas utiliser par les enfants.
ES: No está destinado para uso infantil.
PT: Não destinado ao uso por crianças.
DE: Nicht für die Nutzung durch Kinder bestimmt.
IT: Non destinato all'uso da parte dei bambini.
RO: Nu este destinat utilizării de către copii.



EN: Keep away from fire or other heat sources.
FR: Tenir éloigné du feu ou de toute source de chaleur.
ES: Manténgase alejado del fuego u otras fuentes de calor.
PT: Manter afastado do fogo ou de outras fontes de calor.
DE: Von Feuer oder anderen Wärmequellen fernhalten.
IT: Tenere lontano dal fuoco o da altre fonti di calore.
RO: A nu se lăsa în apropierea focului sau a altor surse de căldură.

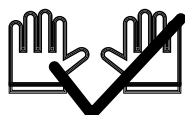

EN: We recommend wearing protective gloves.
FR: Nous recommandons de porter des gants de protection.
ES: Recomendamos usar guantes de protección.
PT: Recomendamos usar luvas de proteção.
DE: Schützen Sie sich mit Handschuhen.
IT: Si consiglia di indossare guanti protettivi.
RO: Recomandăm purtarea mănușilor de protecție.

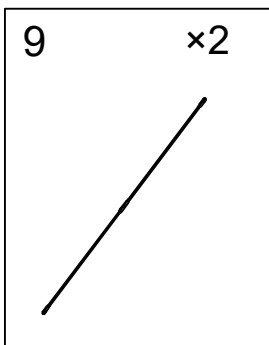
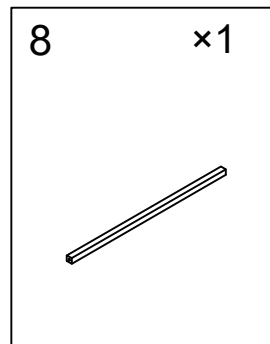
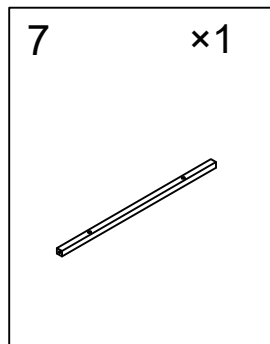
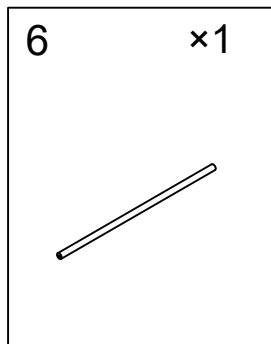
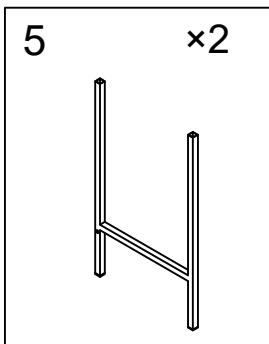
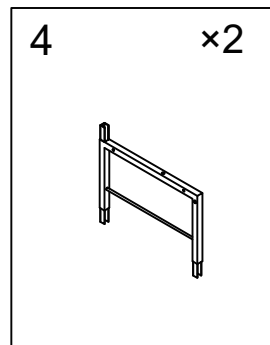
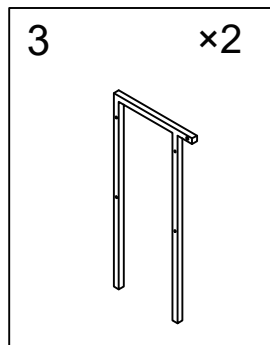
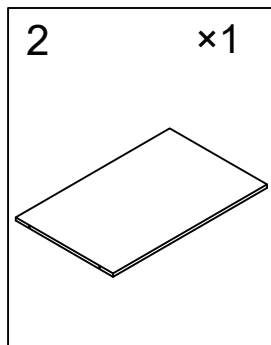
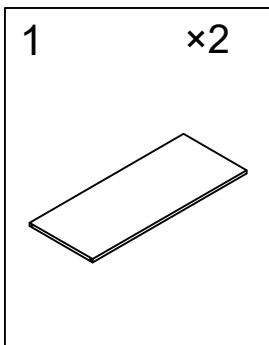

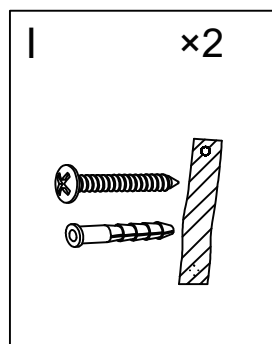
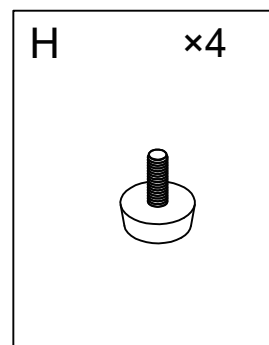
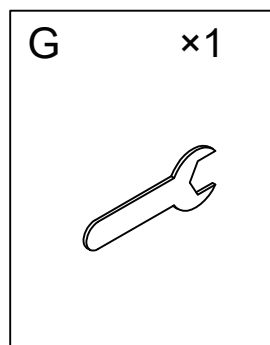
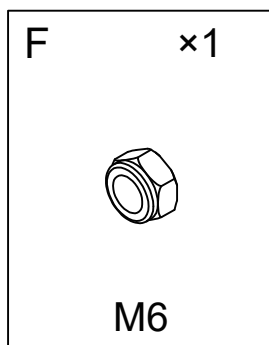
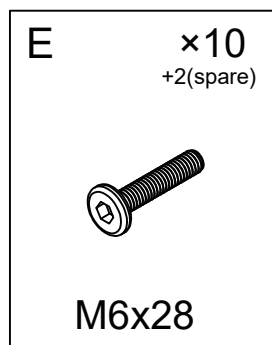
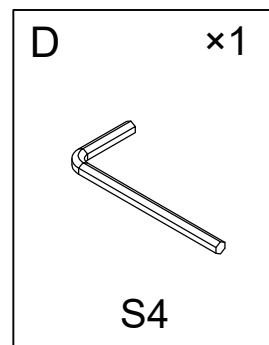
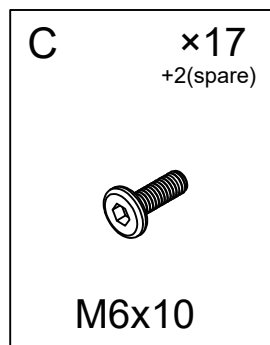
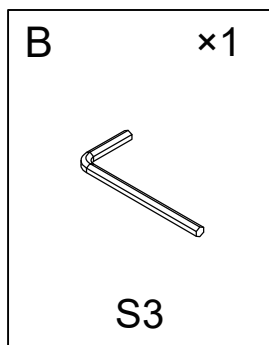
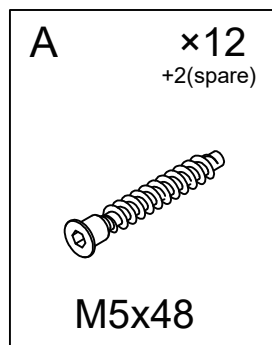

EN: Do not tighten bolts fully until all parts are connected!

FR: Ne serrez pas les boulons à fond tant que toutes les pièces ne sont pas connectées!

ES: No apriete los tornillos completamente hasta que todas las partes están conectadas!

PT: Não aperte totalmente os parafusos até que todas as partes estejam conectadas!

DE: Ziehen Sie die Schrauben erst fest an, wenn alle Teile verbunden sind!

IT: Non serrare completamente i bulloni fino a tutte le parti non sono ancora collegate!

RO: Nu strângeți complet șuruburile până când toate piesele nu sunt conectate!

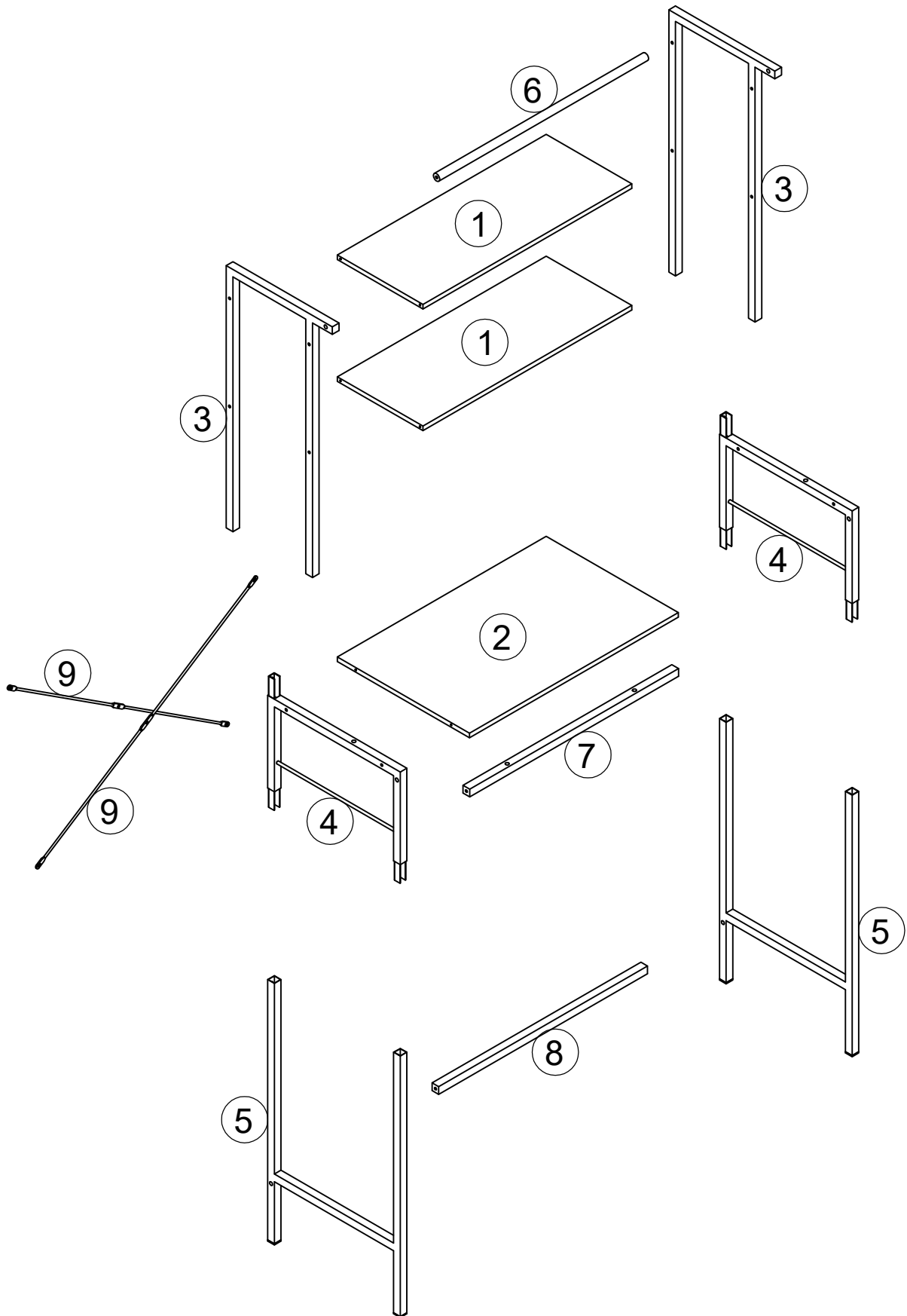

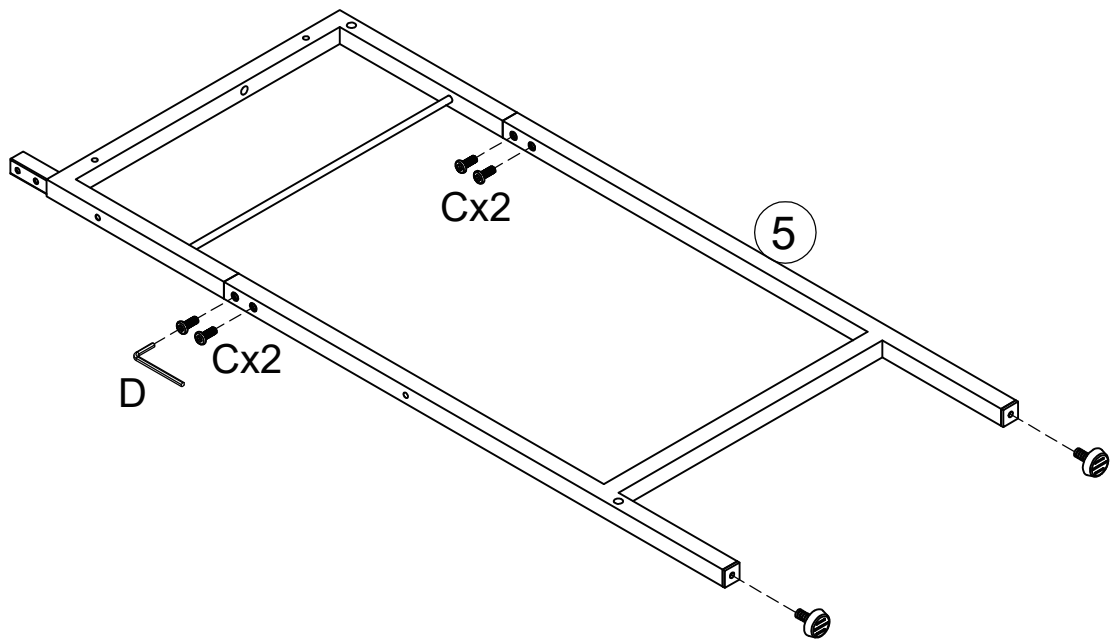
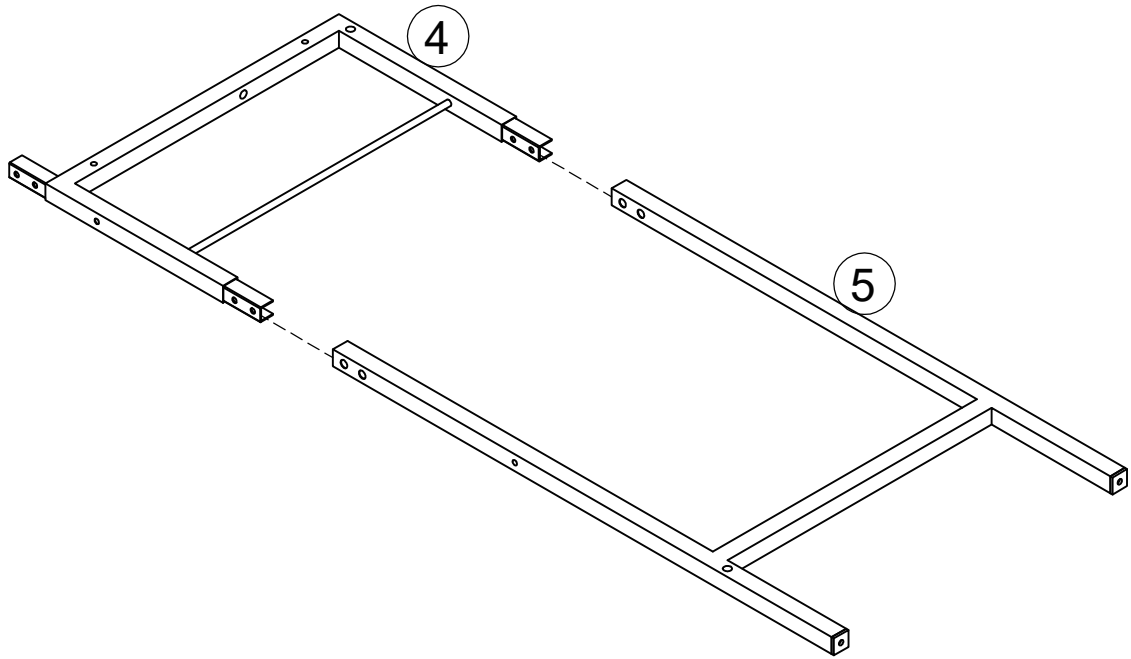
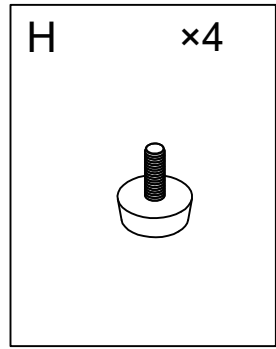
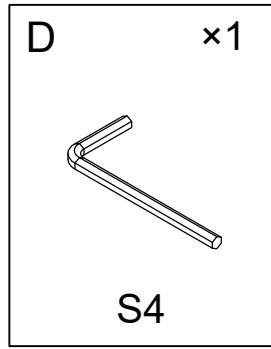
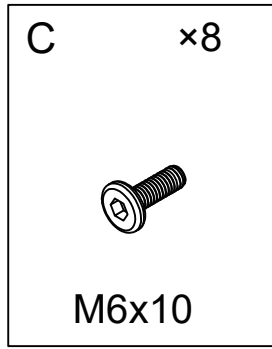

x2

E x2



M6x28

D x1

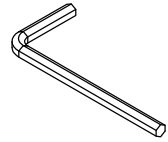

S4

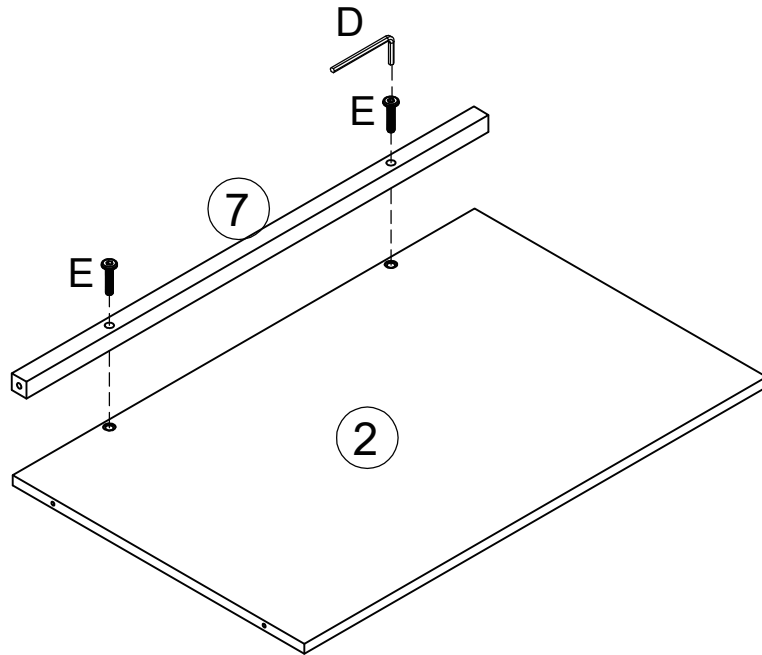

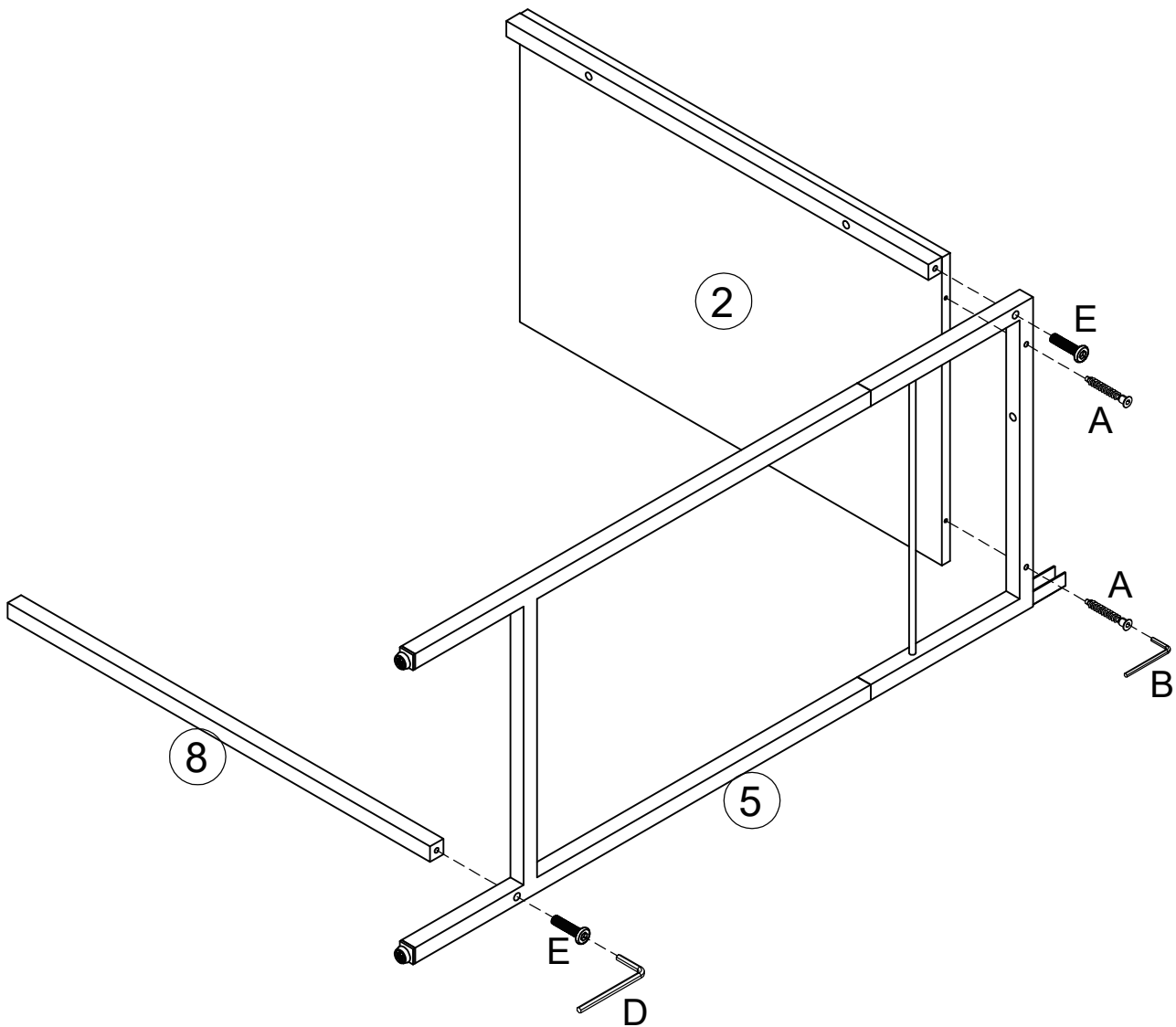
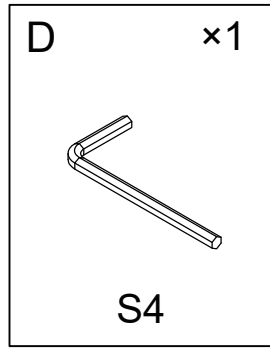
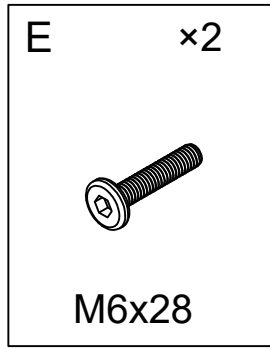
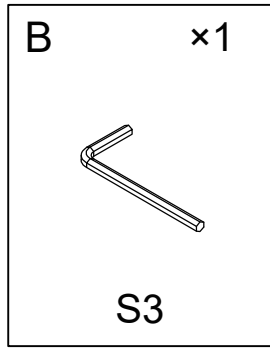
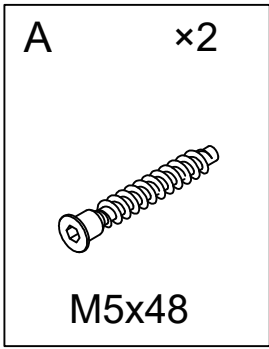

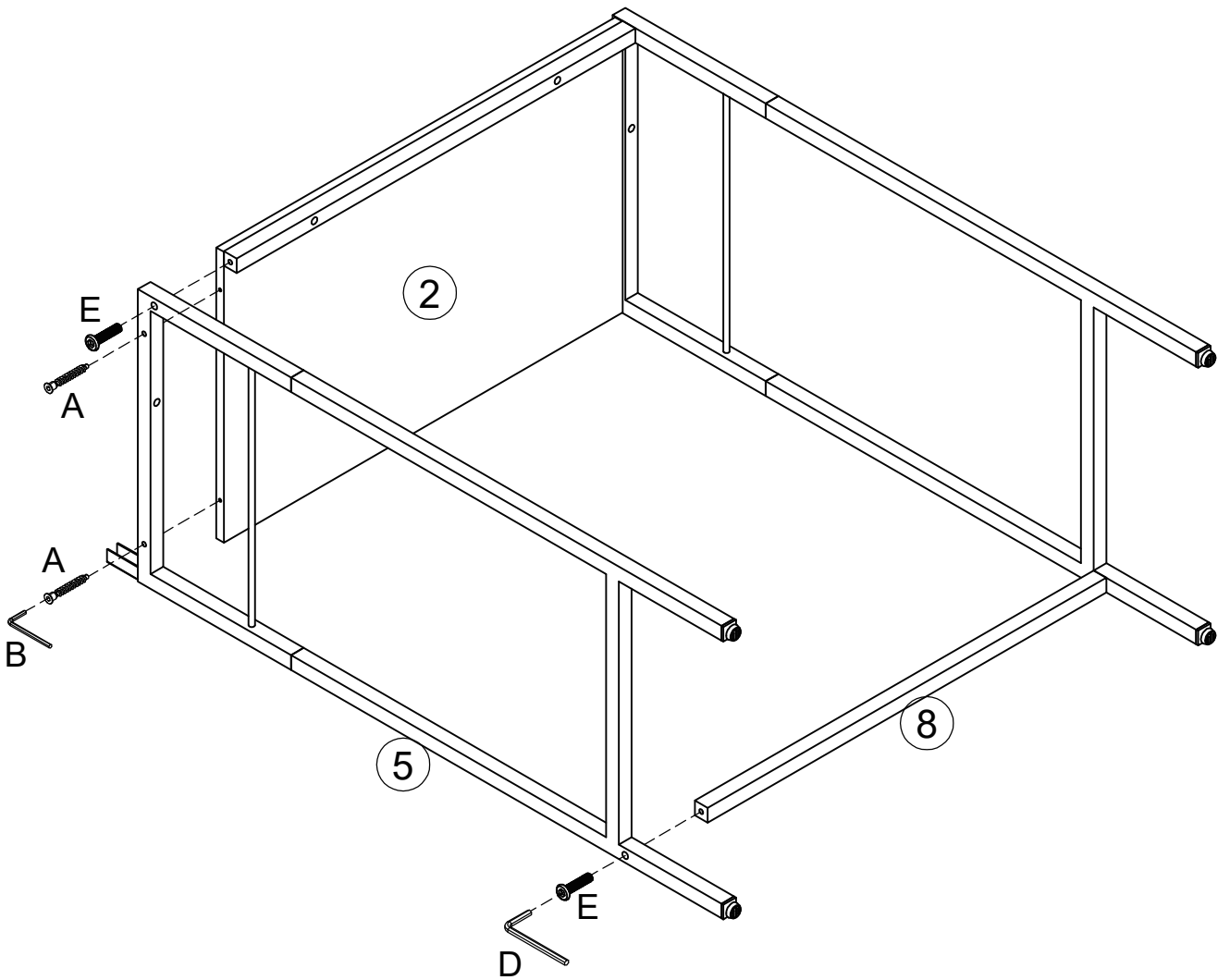
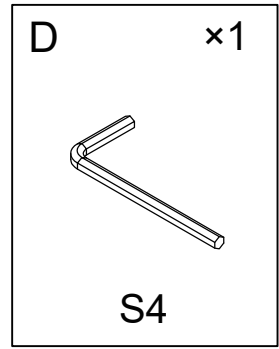
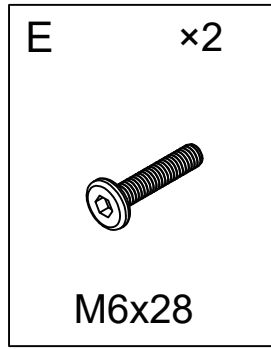
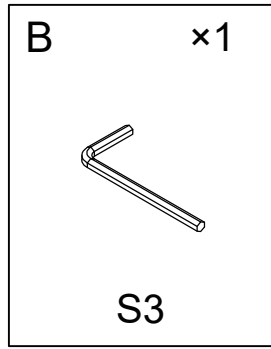
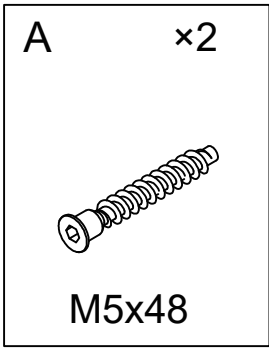

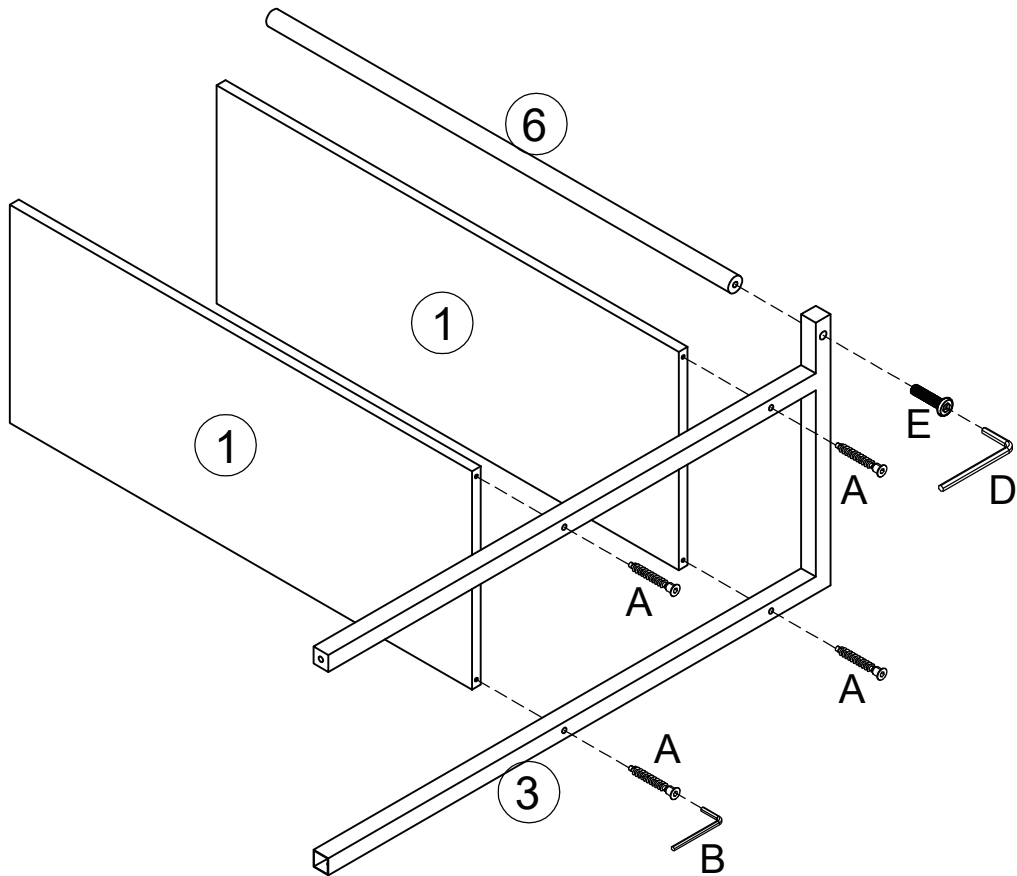
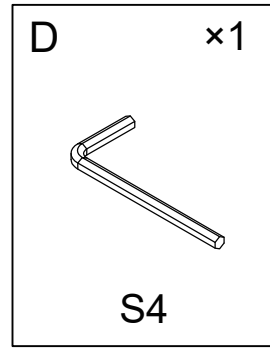
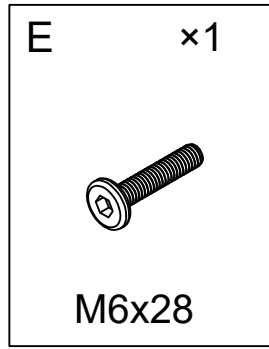
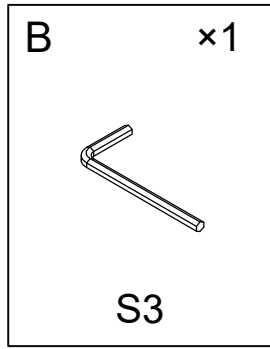
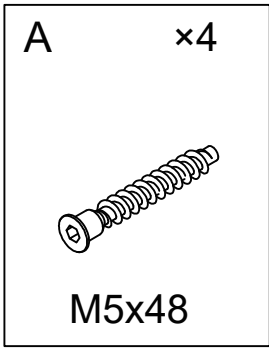

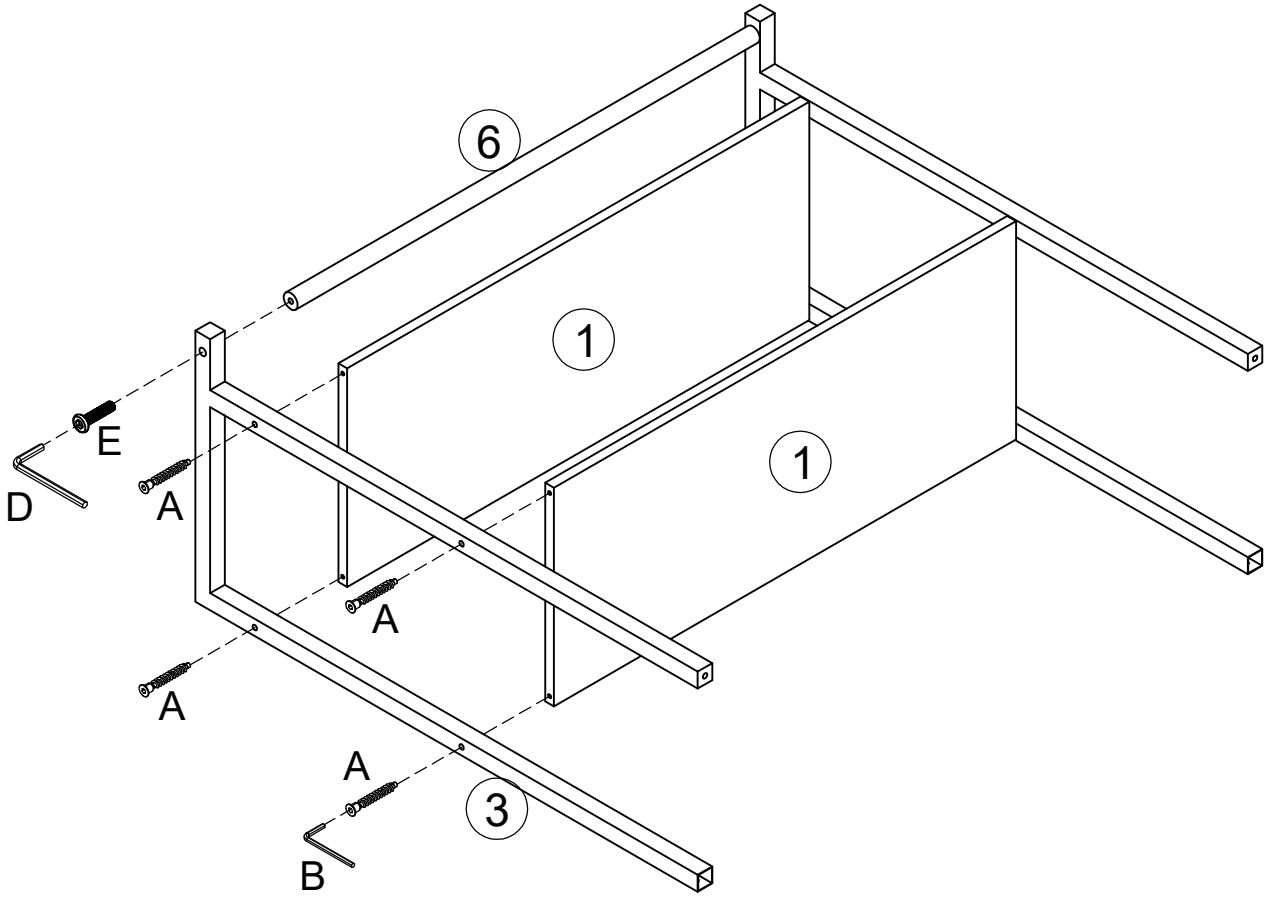
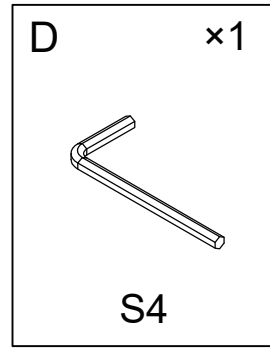
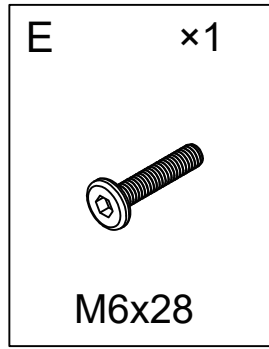
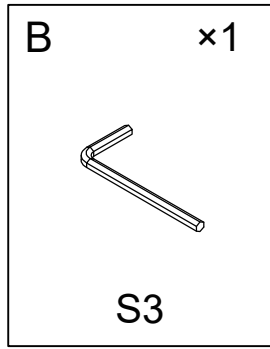
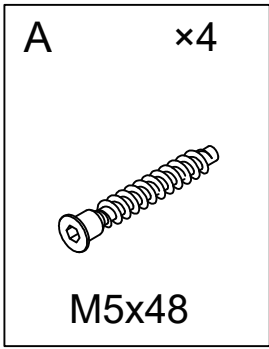

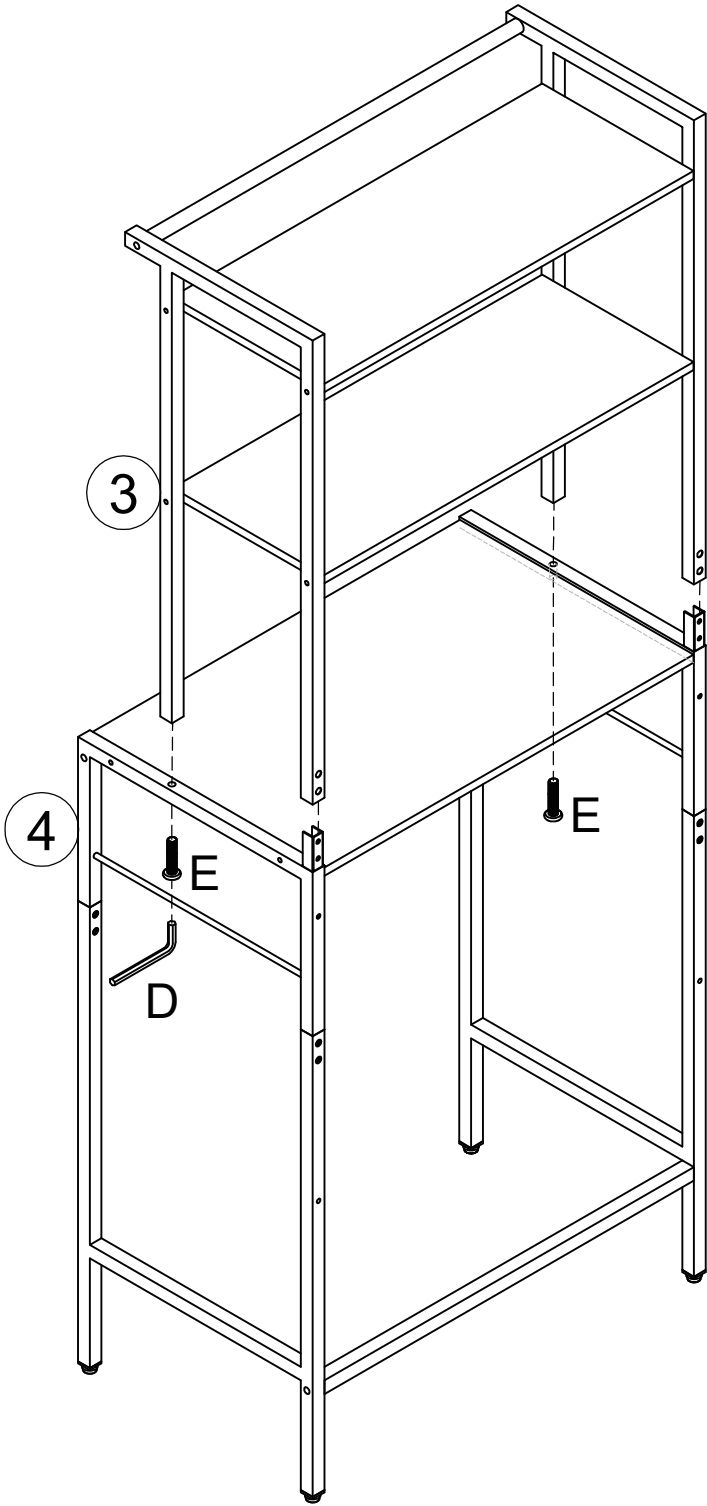
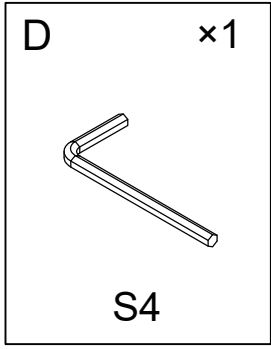
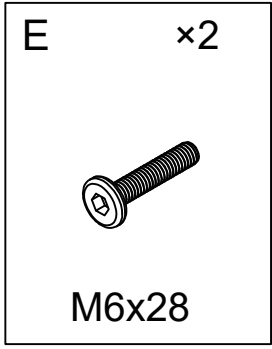

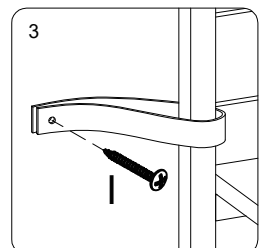
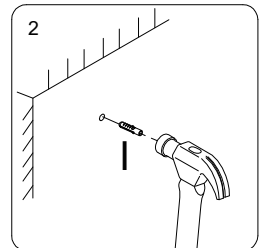
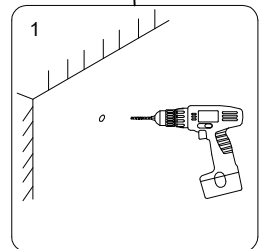
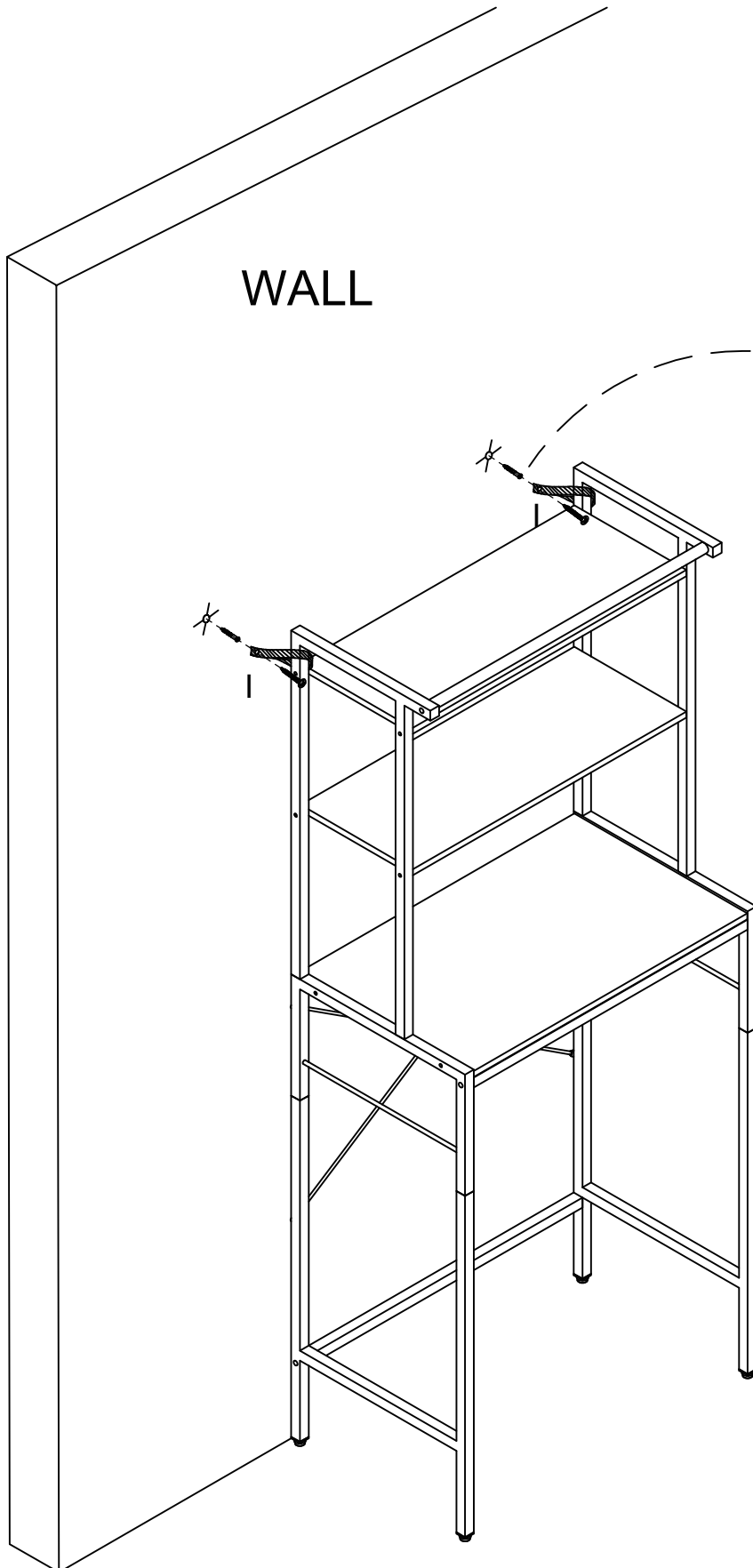
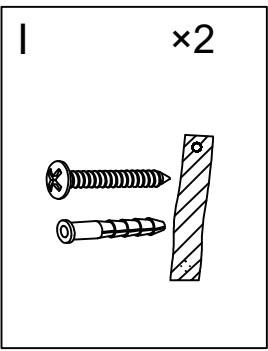

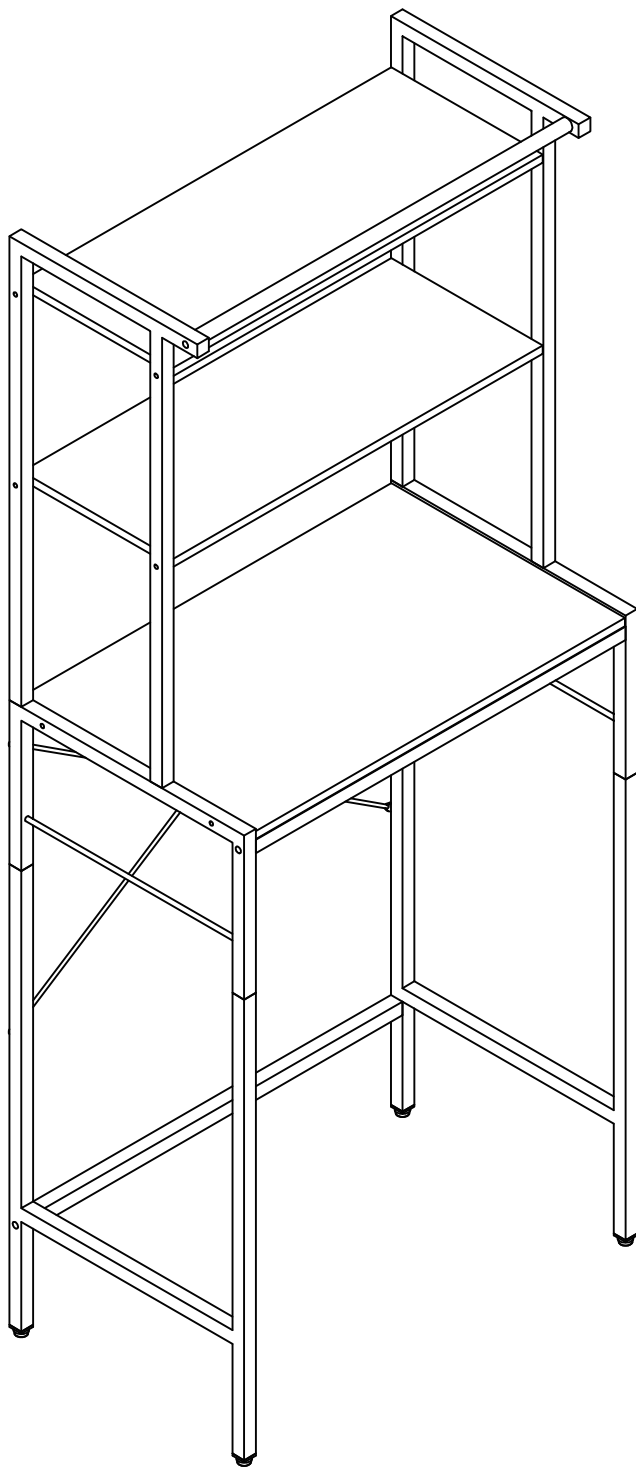



If you have any questions, please contact our customer care center, Our contact details are below:

US

 001-877-644-9366

 customerservice@aosom.com

Imported by Aosom LLC
7777 Center Ave. Suite 430
Huntington Beach, CA 92647-9998 USA
MADE IN CHINA

Wenn Sie Fragen haben, wenden Sie sich bitte an unser Kundendienstzentrum, Unsere Kontaktdaten stehen unten:

DE

 +49 40 87408465

 service@aosom.de

ADRESSE DES IMPORTEURE/Hersteller/REP:
MH Handel GmbH
Wendenstraße 309
D-20537 Hamburg
Germany
IN CHINA HERGESTELLT

If you have any questions, please contact our customer care center, Our contact details are below:

CA

 416-792-6088

 customerservice@aosom.ca

Imported by Aosom Canada Inc.
7270 Woodbine Avenue, Unit 307, Markham,
Ontario Canada L3R 4B9
MADE IN CHINA

Si vous avez la moindre question, veuillez contacter notre centre d'assistance à la clientèle, Nos coordonnées sont les suivantes:

 416-792-6088

 customerservice@aosom.ca

Importé par Aosom Canada Inc.
7270 Woodbine Avenue, unité 307,
Markham, Ontario Canada L3R 4B9
FABRIQUÉ EN CHINE

In caso di dubbio, si prega di contattare il nostro centro assistenza clienti, I nostri dettagli di contatto sono di seguito:

IT

 0039-0249471447

 clienti@aosom.it

IMPORTATO DA/Produttore/REP:
AOSOM Italy srl
Centro Direzionale Milanofiori
Strada 1 Palazzo F1
20057 Assago (MI)
P.I.: 08567220960
FATTO IN CINA

Si tiene alguna pregunta, comuníquese con nuestro Centro de Atención al Cliente, Nuestros datos de contacto son los siguientes:

ES

 0034-931294512

 atencioncliente@aosom.es

IMPORTADOR/Fabricante/REP:
SPANISH AOSOM, S.L.
C/ROC GROS, N°15.08550, ELS HOSTALETES DE
BALENYÀ, SPAIN.
B66295775
HECHO EN CHINA

Se tiver alguma dúvida, por favor contacte o nosso Centro de Atendimento ao Cliente, Os nossos dados de contacto são os seguintes:

 0034-931294512

 info@aosom.pt.

IMPORTADOR/Fabricante/REP:
SPANISH AOSOM, S.L.
C.ROC GROS N.15, 08550. ELS HOSTALETES DE
BALENYÀ
FEITO NA CHINA

If you have any questions, please contact our customer care center, Our contact details are below:

UK

 0044-800-240-4004

 enquiries@mhstar.co.uk

IMPORTER ADDRESS:
MH STAR UK Ltd
1 Northampton Cross Logistics Park
Northampton Cross Road
Northampton
NN4 9FH
MADE IN CHINA

Si vous avez la moindre question, veuillez contacter notre centre d'assistance à la clientèle, Nos coordonnées sont les suivantes:

FR

 0033-1-84166106

 aosom@mhfrance.fr

Importé par/Fabricant/REP:
MH FRANCE
2 Rue Maurice Hartmann
92130 Issy Les Moulineaux
France
FABRIQUÉ EN CHINE



FR

**DONNEZ
OU
RECYCLEZ**



ASSOCIATION

OU



LIVRAISON

OU



DÉCHÈTERIE

Adresses sur quefairedemesdechets.fr