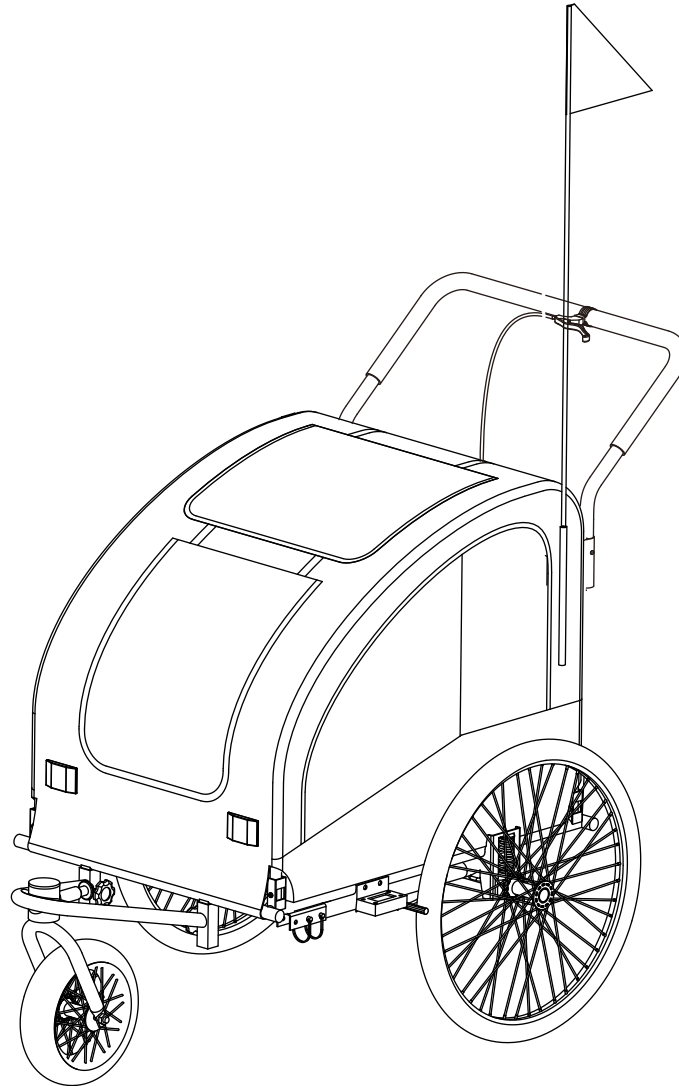

PawHut

IN260200082V01

D00-051V01

12

STEPS



0.5 HR



EN_ IMPORTANT, RETAIN FOR FUTURE REFERENCE: READ CAREFULLY.

FR_ IMPORTANT: A LIRE ATTENTIVEMENT ET À CONSERVER POUR CONSULTATION ULTÉRIEURE.

ES_ IMPORTANTE, LEA Y GUARDE PARA FUTURAS REFERENCIAS.

PT_ IMPORTANTE: LEIA ATENTAMENTE E GUARDE PARA CONSULTA FUTURA.

DE_ WICHTIG! SORGFÄLTIG LESEN UND FÜR SPÄTER NACHSCHLAGEN AUFBEWAHREN.

IT_ IMPORTANTE! CONSERVARE IL PRESENTE MANUALE PER FUTURO RIFERIMENTO E LEGGERLO ATTENTAMENTE.

RO_ IMPORTANT: CITIȚI CU ATENȚIE ȘI PĂSTRAȚI PENTRU CONSULTARE VIITOARE.

EN

1. Do not modify the trailer.
2. Always check all parts of the trailer are secure, tight and properly connected.
3. Do not lift the trailer up when the pet is inside.
4. Do not exceed 13 Km/H (8 MPH) maximum speed
5. Never use the trailer on uneven ground.
6. Never park the trailer near dangerous and busy roads.
7. The rider must wear an approved safety helmet.
8. Check the air pressure before every trip.
9. Be careful while riding, especially in the corners and downgrade.
10. Do not store or use this trailer in areas exposed to high or low temperatures or humidity for prolonged periods.

FR

1. Ne modifiez pas techniquement la remorque.
2. Vérifiez toujours que toutes les parties de la remorque sont bien connectées correctement.
3. Ne soulevez pas la remorque lorsque l'animal est à l'état.
4. Ne pas excéder la vitesse maximale de 13 Km/H (8 MPH)
5. N'utilisez jamais la remorque sur un terrain inégal.
6. Ne garez jamais la remorque près d'une route dangereuse.
7. Le conducteur doit porter des casques de sécurité homologués.
8. Vérifiez la pression d'air avant chaque voyage.
9. faire attention en roulant, surtout dans les virages et les descentes.
10. Ne stockez pas ou utilisez cette remorque dans les zones exposées à des températures ou à une humidité élevées ou basses pendant une longue période.

ES

1. No modifique el remolque técnicamente.
2. Siempre inspeccione que todas las partes del remolque estén conectadas de manera correcta y firme.
3. No levante el remolque cuando la mascota esté adentro.
4. No exceda la velocidad máxima de los 13 km / H (8 MPH) al conducir
5. Nunca utilice el remolque en un lugar irregular.
6. Nunca estacione el remolque cerca de una carretera peligrosa.
7. El ciclista debe usar cascos de seguridad aprobados.
8. Compruebe la presión del aire antes de cada viaje.
9. Ten cuidado al conducir, especialmente en las curvas y en las bajadas.
10. No almacene ni utilice el remolque en áreas expuestas a altas o bajas temperaturas o humedades durante largo tiempo.

PT

1. Não modificar o reboque.
2. Verificar sempre se todas as partes do reboque estão seguras, apertadas e devidamente conectadas.
3. Não levantar o reboque quando o animal de estimação estiver no interior.
4. não exceder a velocidade máxima de 13 Km/H (8 MPH)
5. Nunca utilizar o reboque em terrenos irregulares.
6. Nunca estacionar o reboque perto de estradas perigosas e movimentadas
7. O condutor deve usar um capacete de segurança aprovado.
8. Verificar a pressão do ar antes de cada passeio.
9. ter cuidado ao conduzir, especialmente nas curvas e descidas.
10. Não armazenar ou utilizar este reboque em áreas expostas a temperaturas altas ou baixas ou humidade durante períodos prolongados.

DE

1. Nehmen Sie keine technischen Änderungen am Anhänger vor.
2. Überprüfen Sie immer, ob alle Teile des Anhängers richtig angeschlossen und befestigt sind.
3. Heben Sie den Anhänger nicht an, wenn sich das Haustier darin befindet.
4. Überschreiten Sie nicht die Höchstgeschwindigkeit von 13 km/h (8 mph)
5. Nutzen Sie den Anhänger niemals an unebenen Stellen.
6. Parken Sie den Anhänger niemals in der Nähe einer gefährlichen Straße.
7. Der Fahrer sollte zugelassene Schutzhelme tragen.
8. Überprüfen Sie den Luftdruck vor jeder Fahrt.
9. Seien Sie beim Fahren vorsichtig, besonders in den Kurven und beim Gefälle.
10. Lagern oder verwenden Sie diesen Anhänger nicht in Bereichen, die längere Zeit hohen oder niedrigen Temperatur oder Luftfeuchtigkeit ausgesetzt sind.

IT

1. Non modificare il rimorchio tecnicamente.
2. Controllare sempre che tutte le parti del rimorchio siano connesse correttamente e strette in sicurezza.
3. Non sollevare il rimorchio quando l'animale si trova al suo interno.
4. Non superare la velocità massima di 13 Km/H (8 MPH)
5. Non utilizzare mai il rimorchio su un terreno irregolare.
6. Non parcheggiare mai il rimorchio vicino a strade pericolose.
7. L'utente alla guida deve indossare un elmetto di sicurezza omologato.
8. Controllare la pressione dell'aria prima di ogni uscita.
9. Fare attenzione durante la guida, soprattutto nelle curve e nelle discese.
10. Non conservare o utilizzare questo rimorchio a lungo in aree soggette a temperature particolarmente alte o basse, o in caso di umidità.

RO

1. Nu modificați remorca.
2. Verificați întotdeauna dacă toate părțile remorcii sunt fixate, strânse și conectate corespunzător.
3. Nu ridicați remorca când animalul de companie se află în interior.
4. Nu depășiți viteza maximă de 13 km/h (8 MPH).
5. Nu utilizați niciodată remorca pe teren accidentat.
6. Nu parcați niciodată remorca în apropierea drumurilor periculoase și aglomerate.
7. Ciclul trebuie să poarte o cască de protecție omologată.
8. Verificați presiunea aerului înainte de fiecare călătorie.
9. Fiți atenți în timpul mersului, în special în viraje și la coborâri.
10. Nu depozitați și nu utilizați această remorcă în zone expuse la temperaturi ridicate sau scăzute sau la umiditate pentru perioade îndelungate.

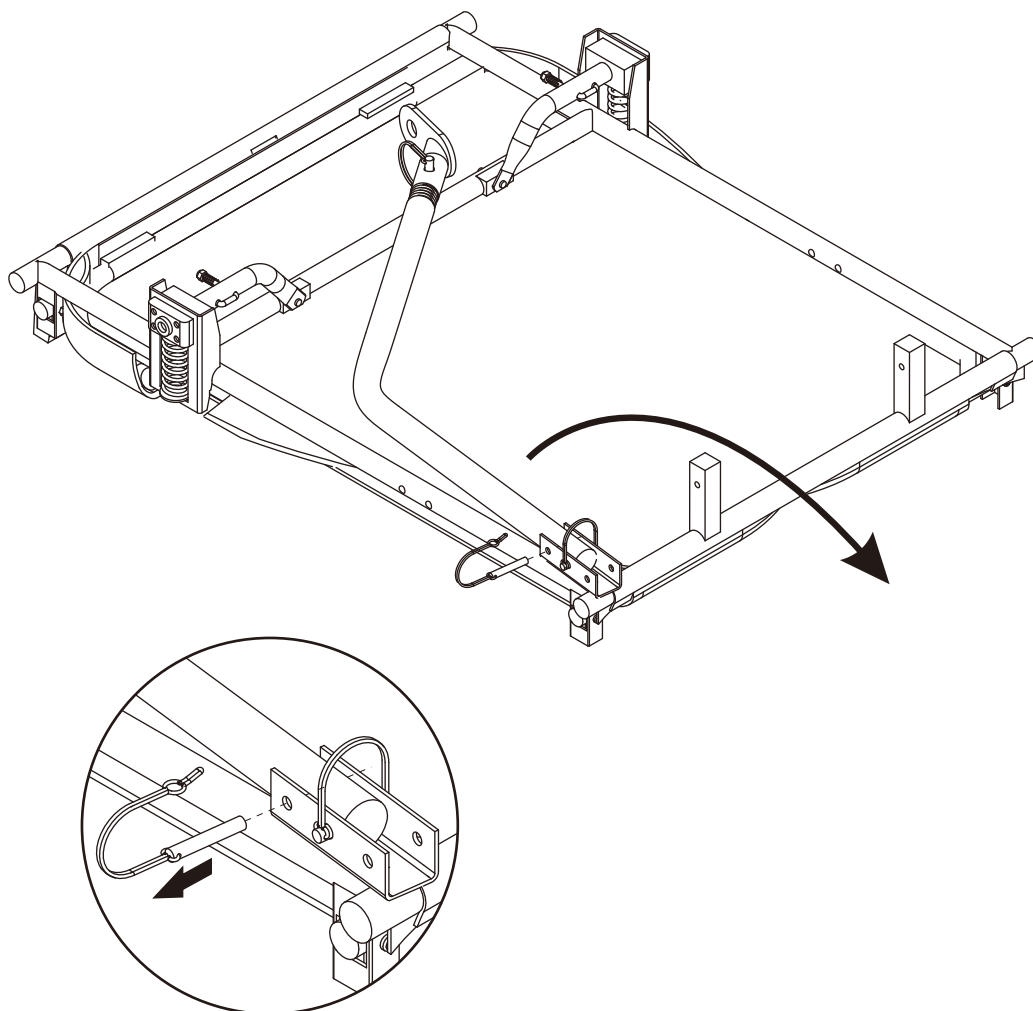
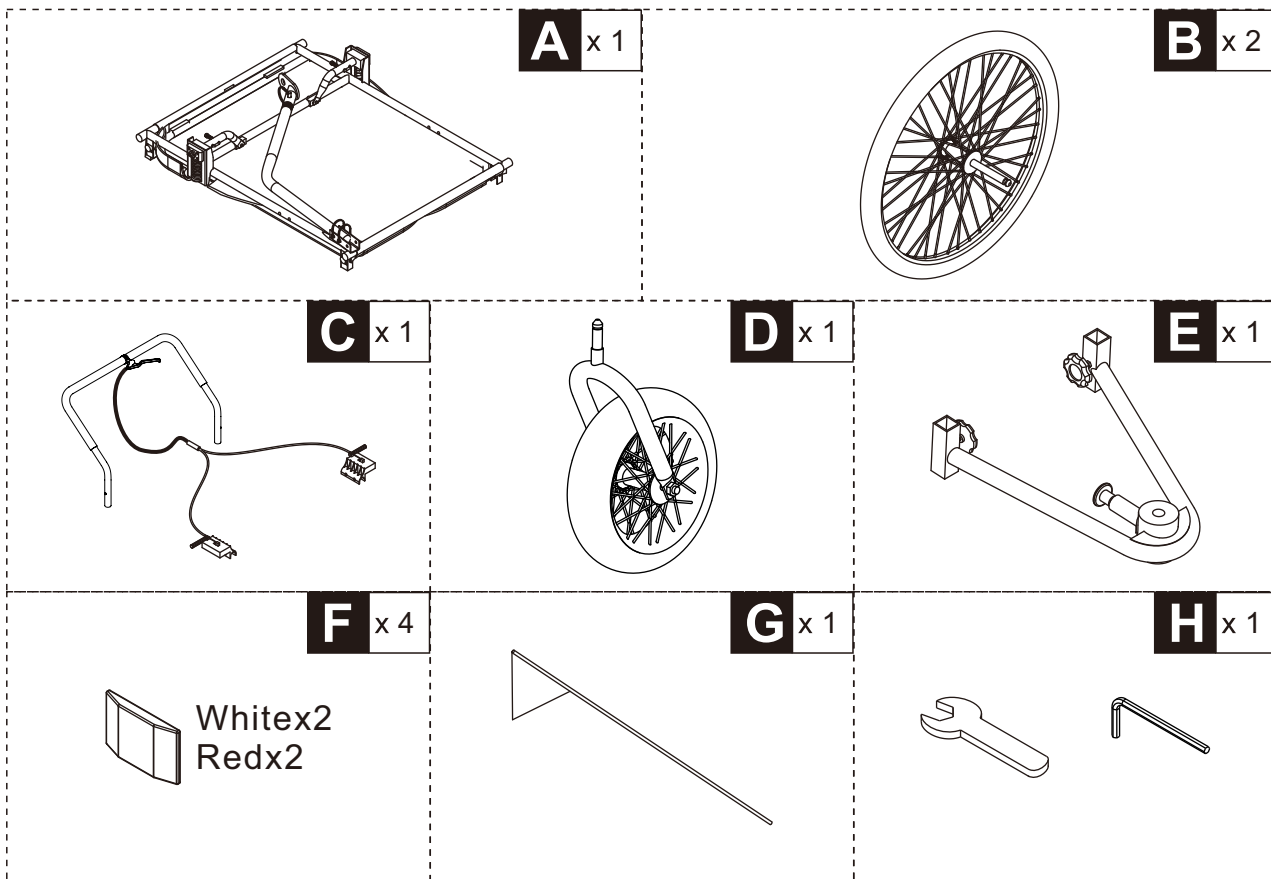

02

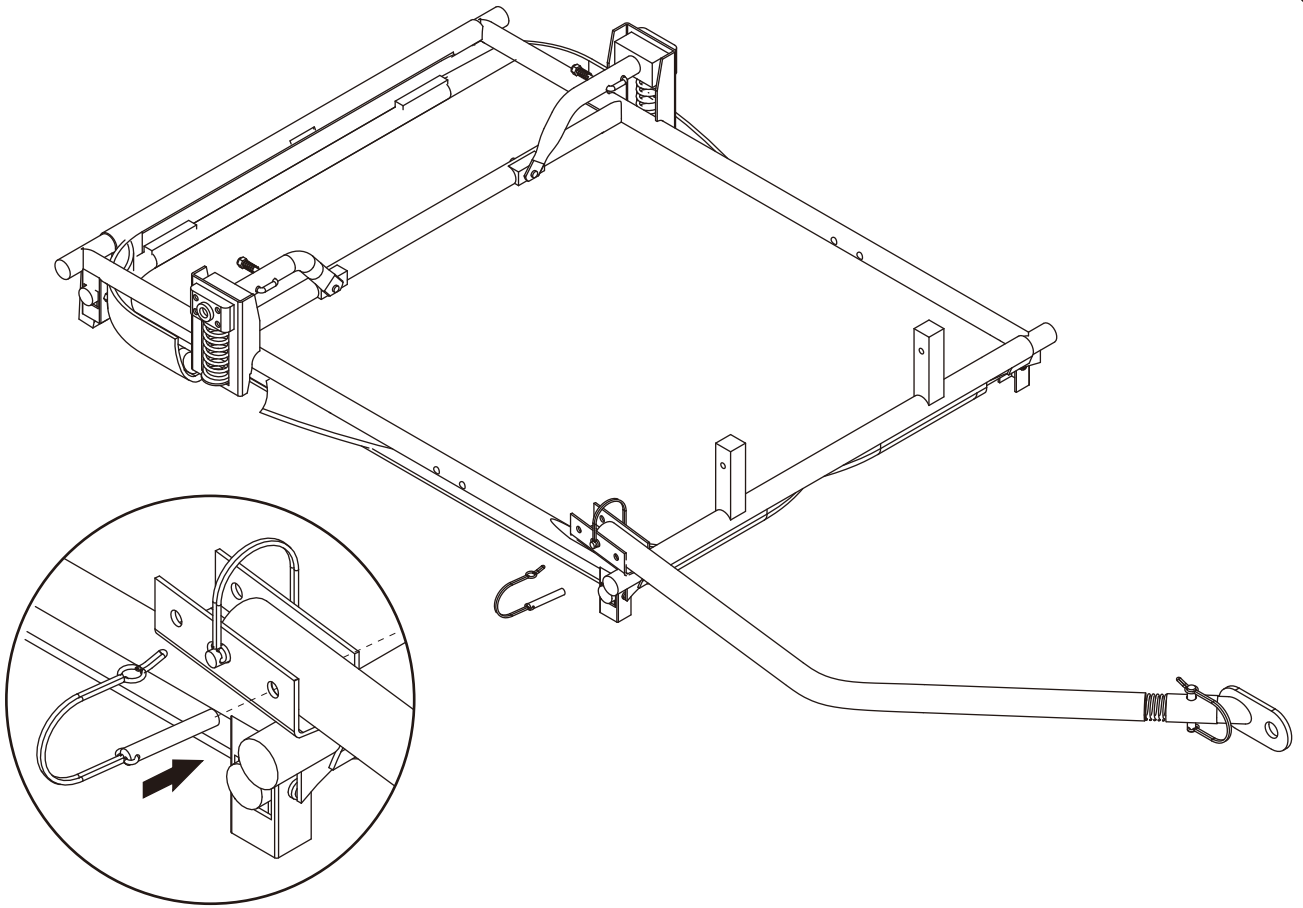

03

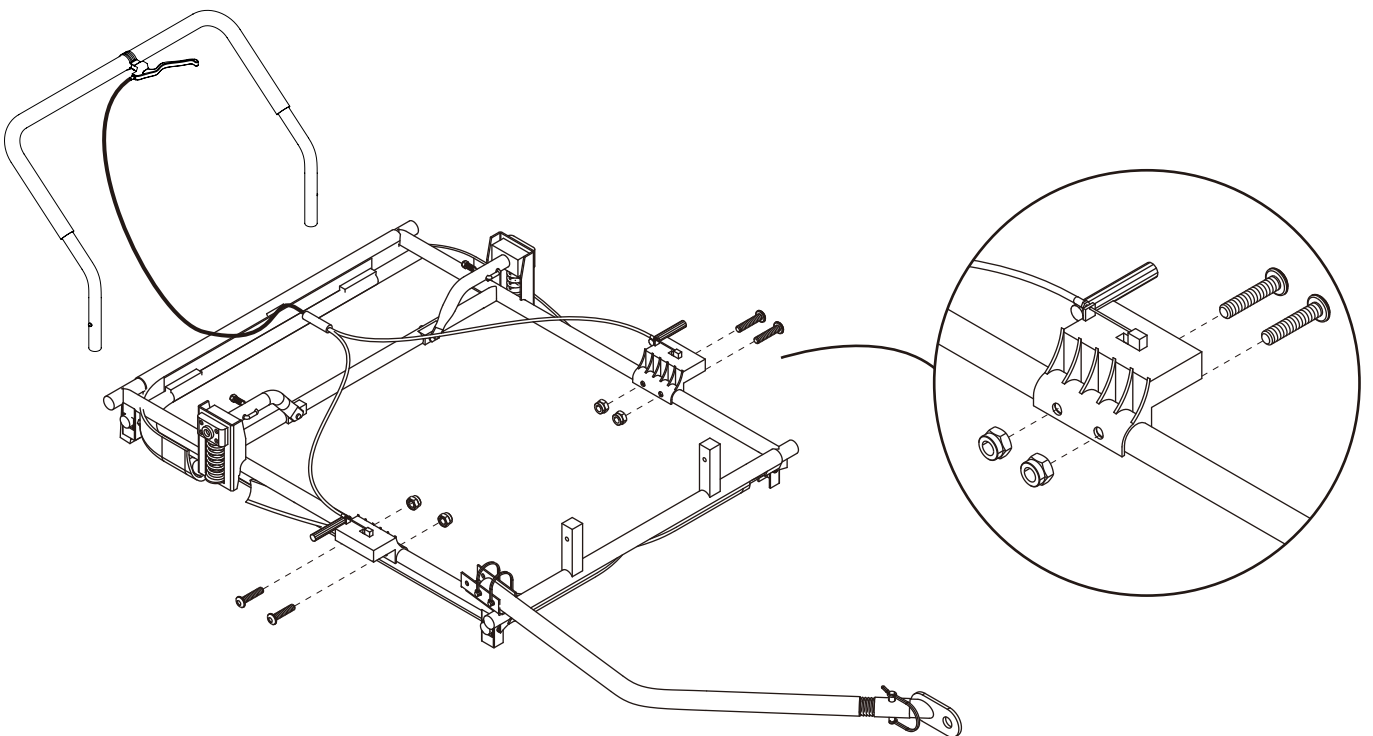

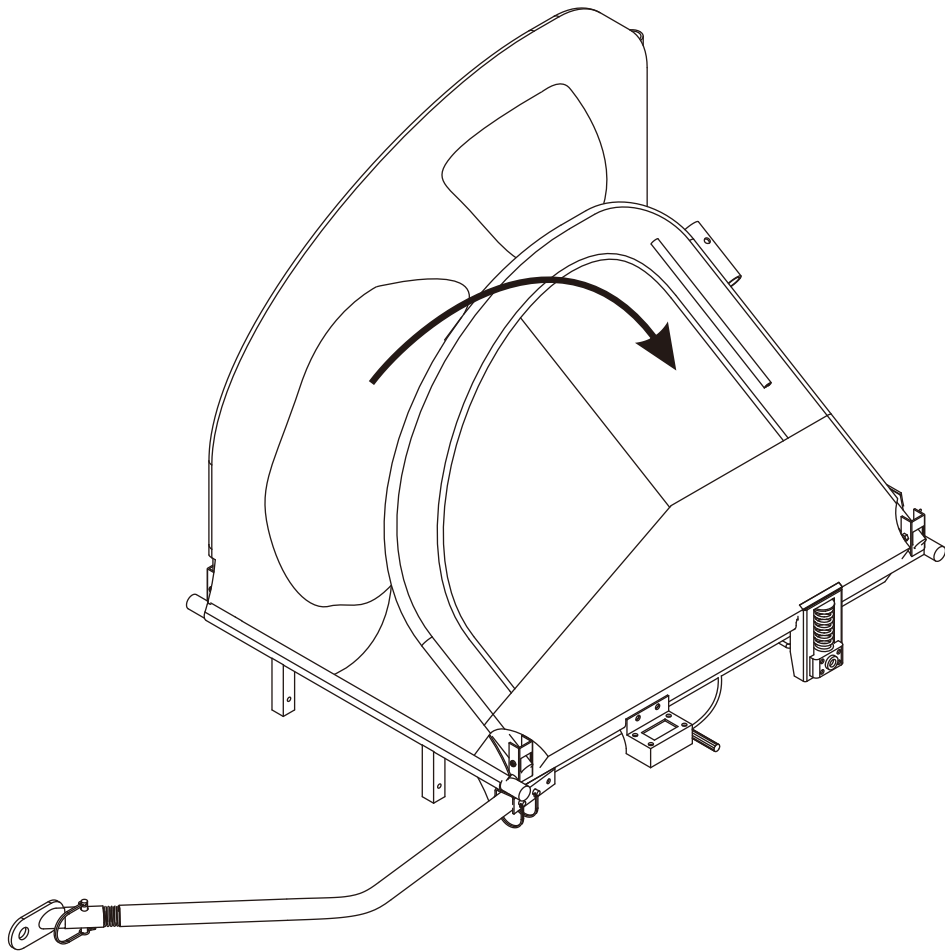
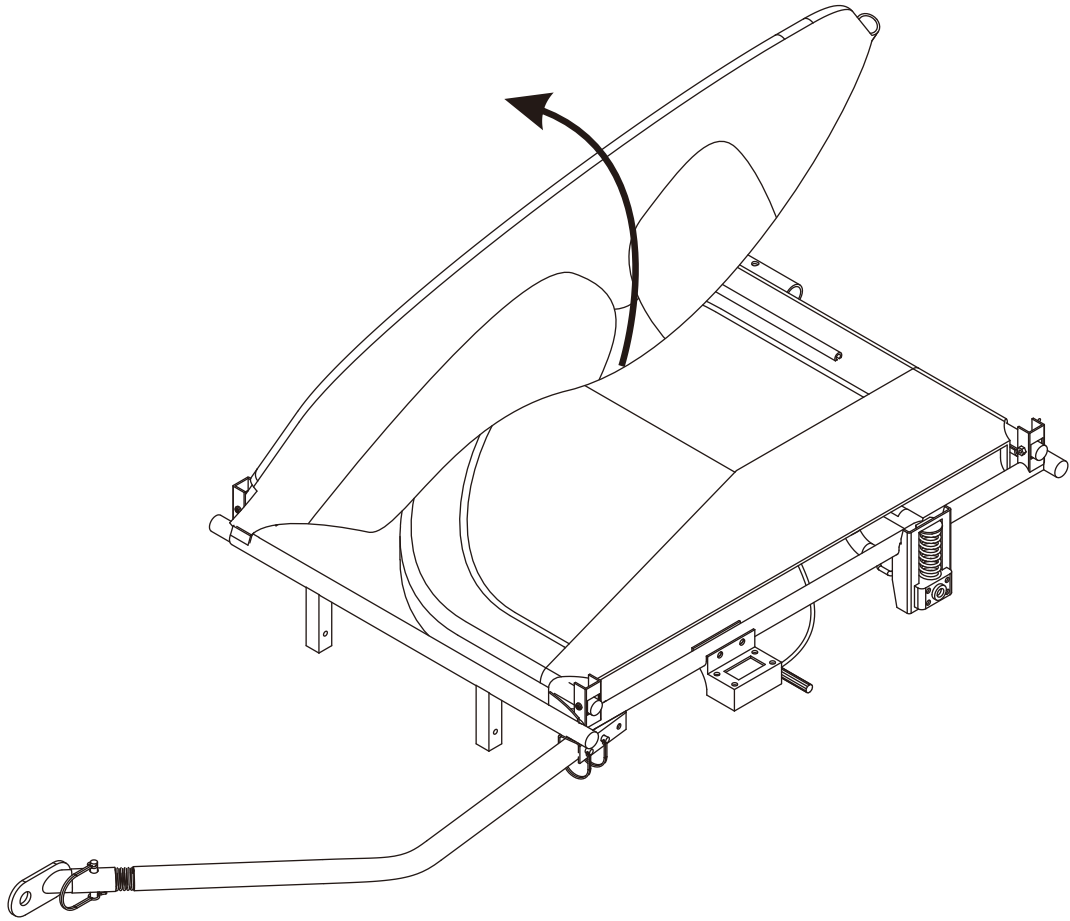

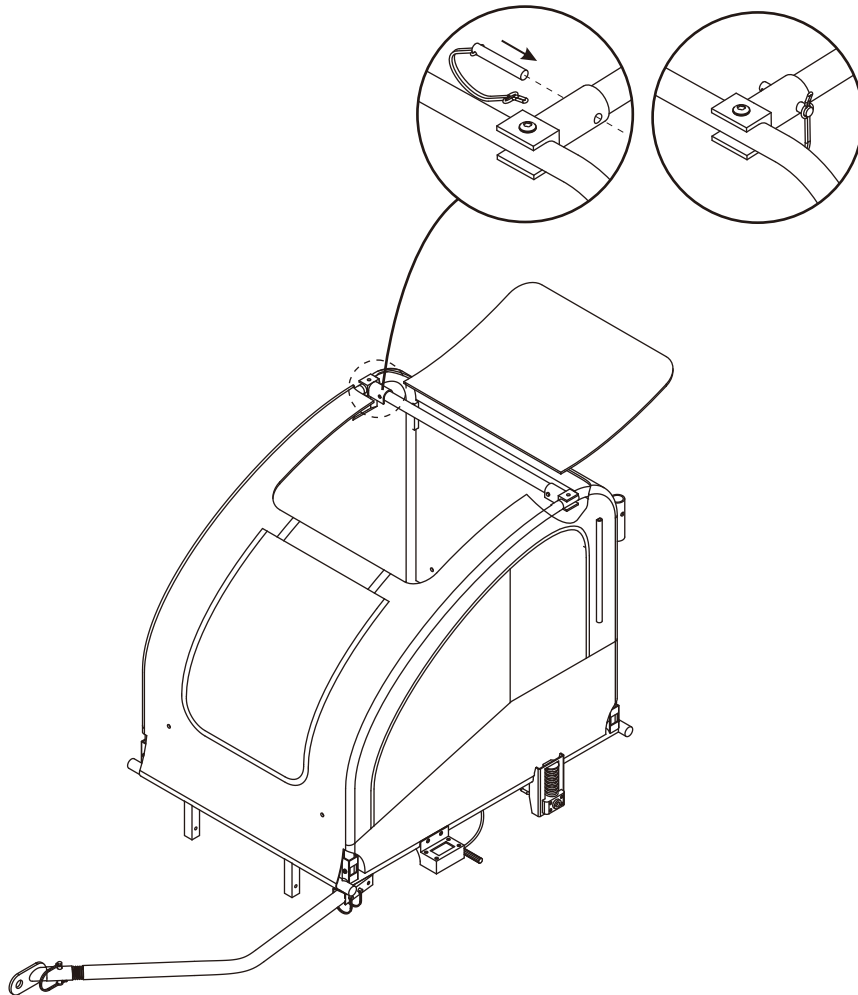
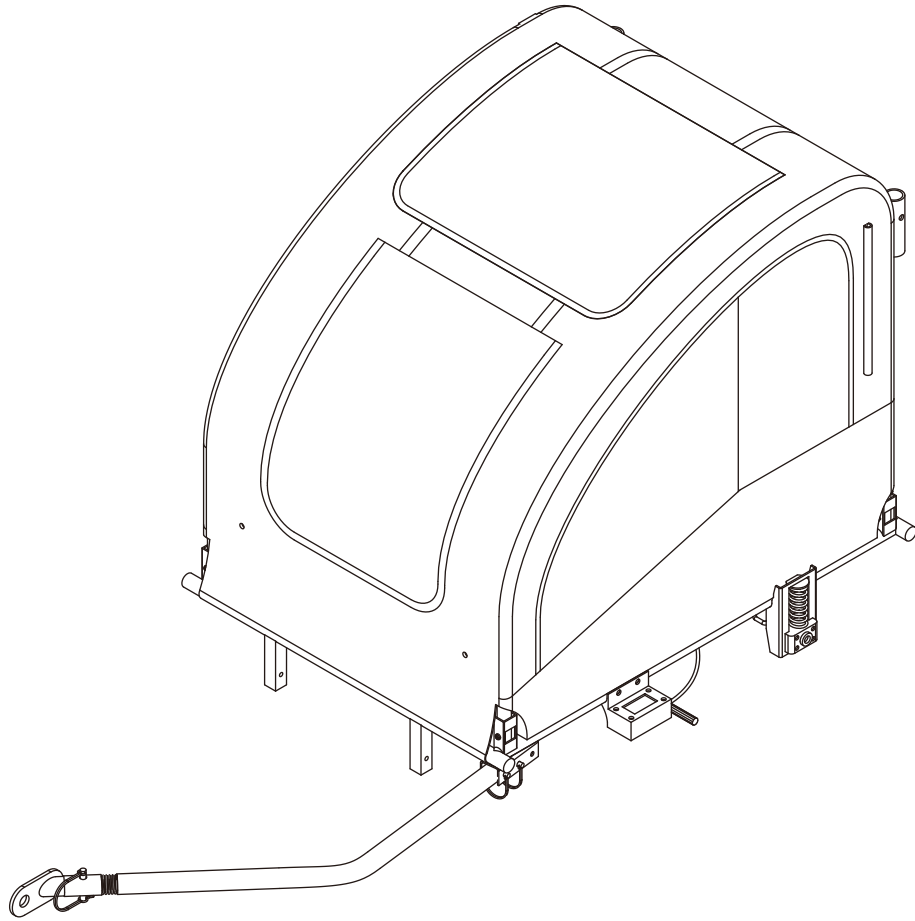

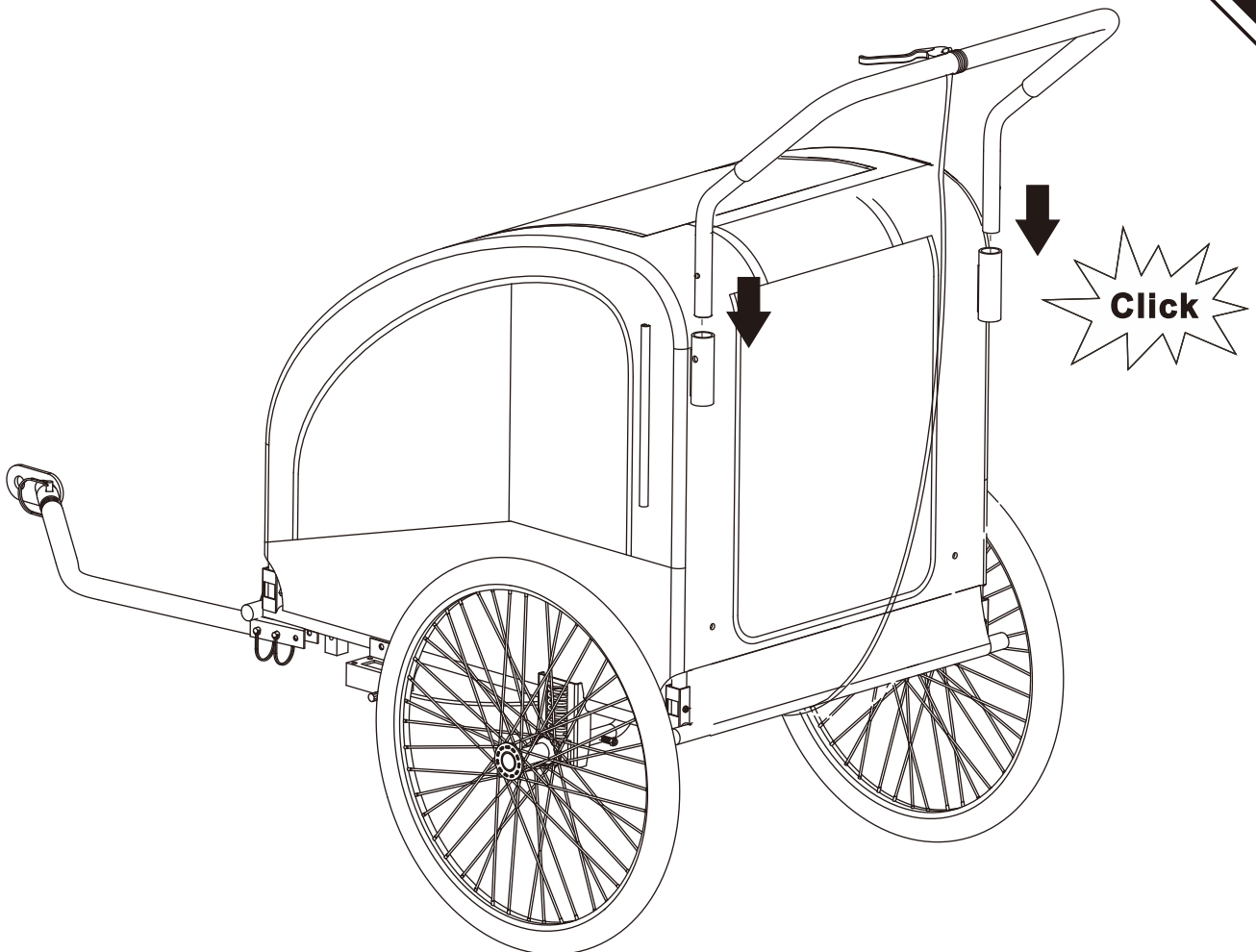
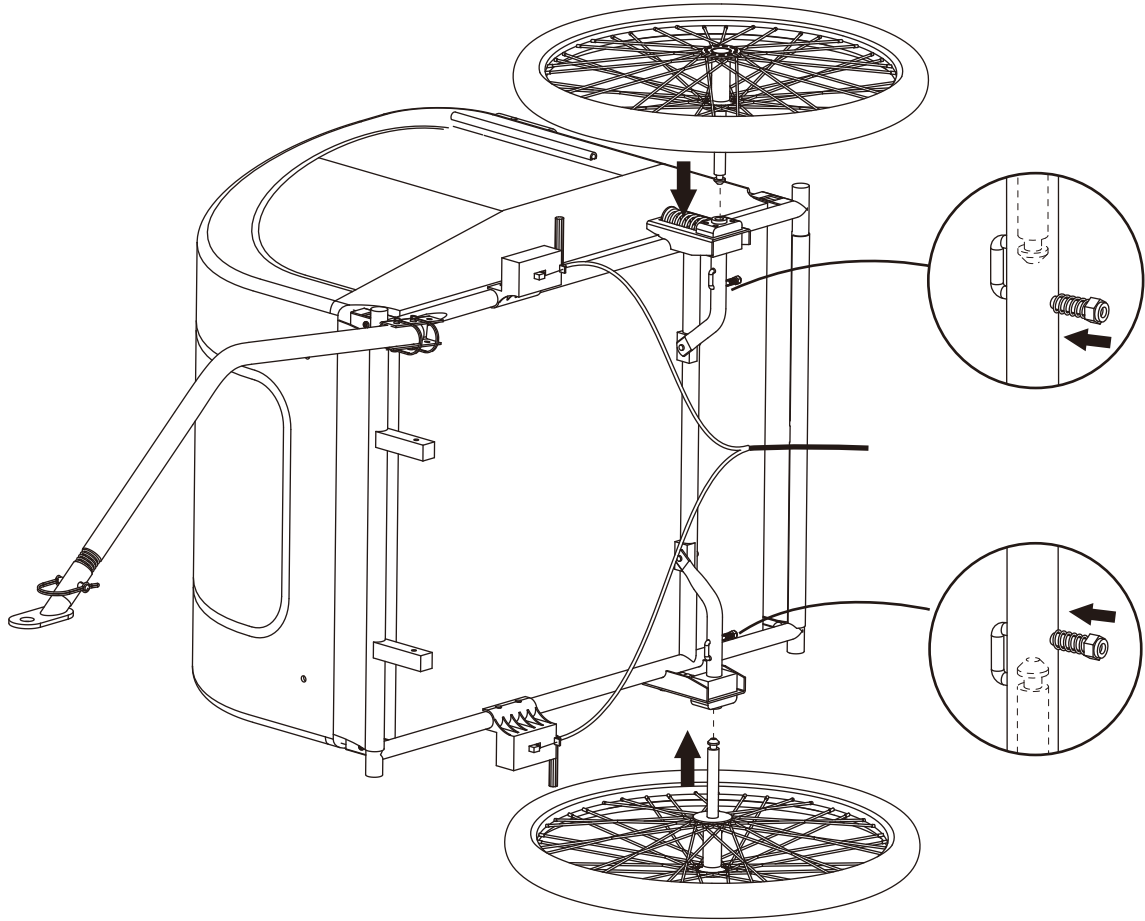

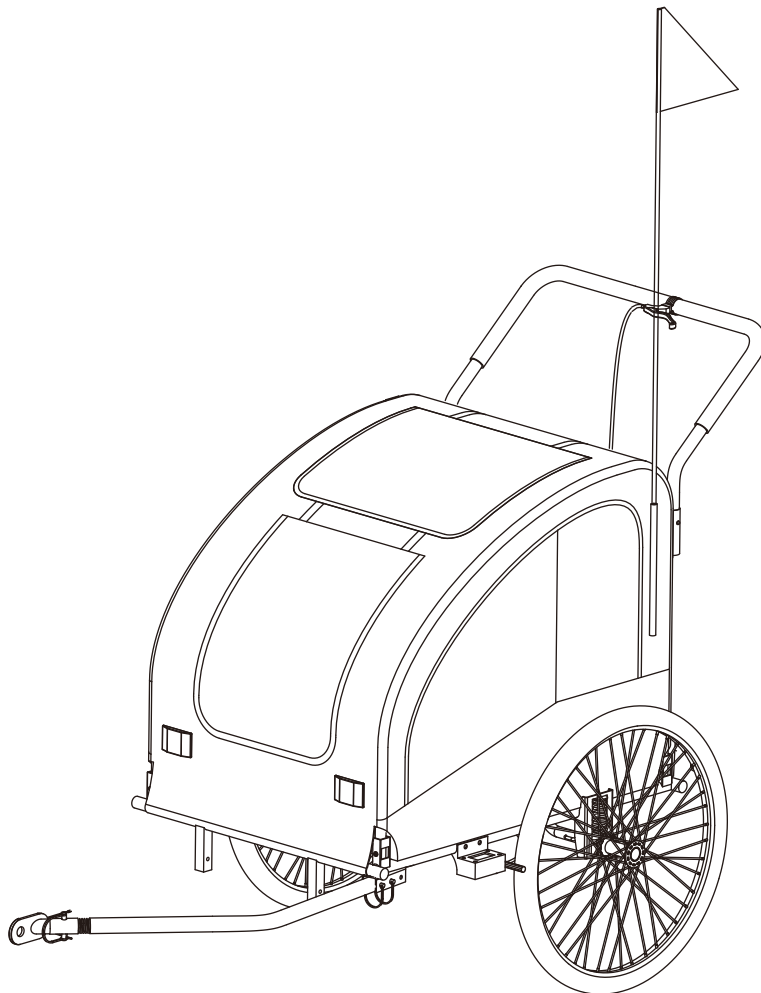
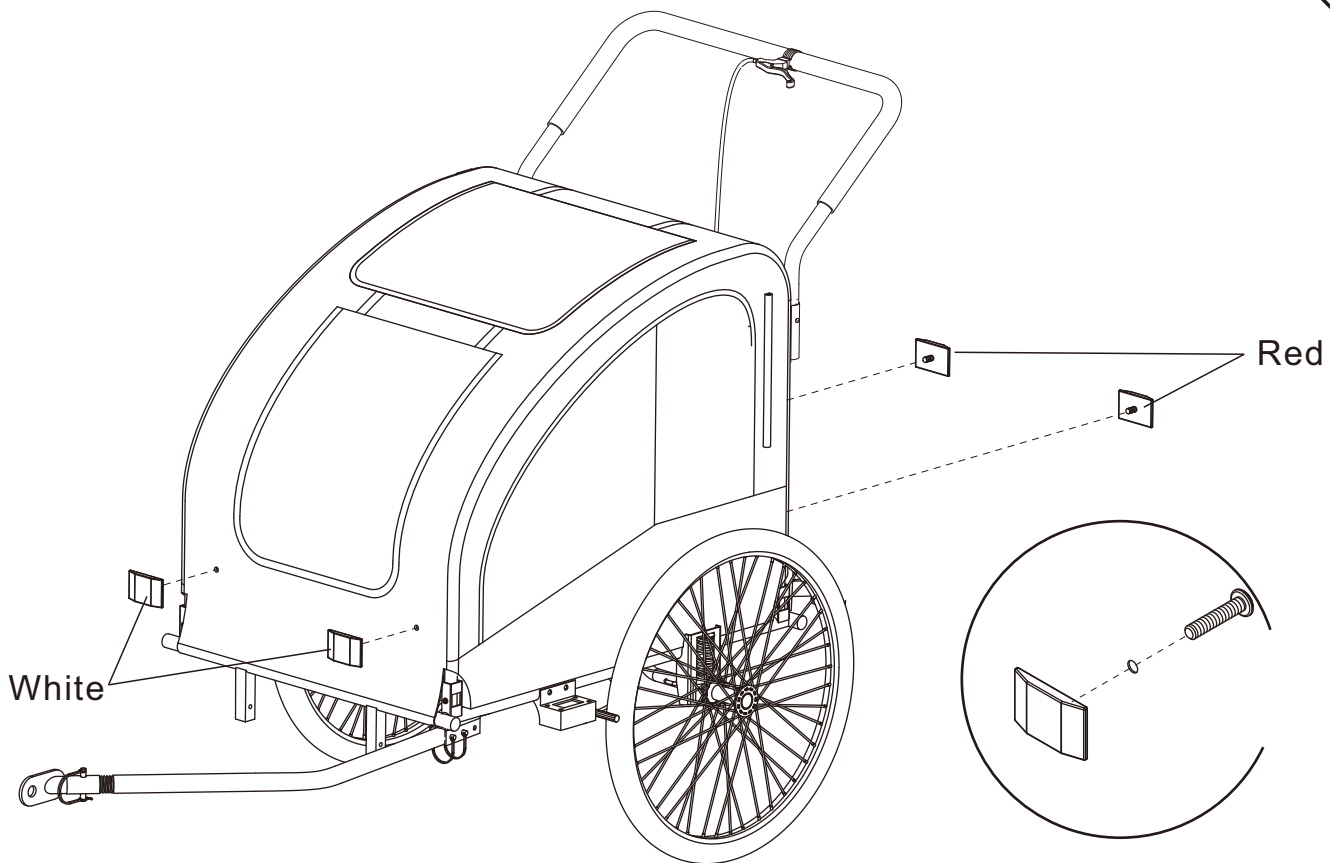

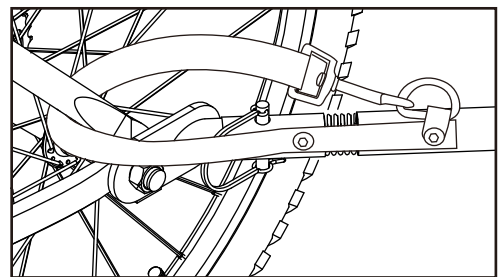
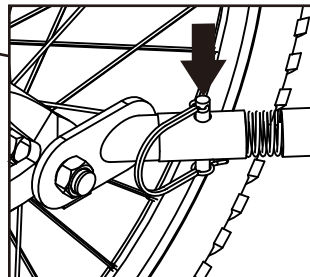
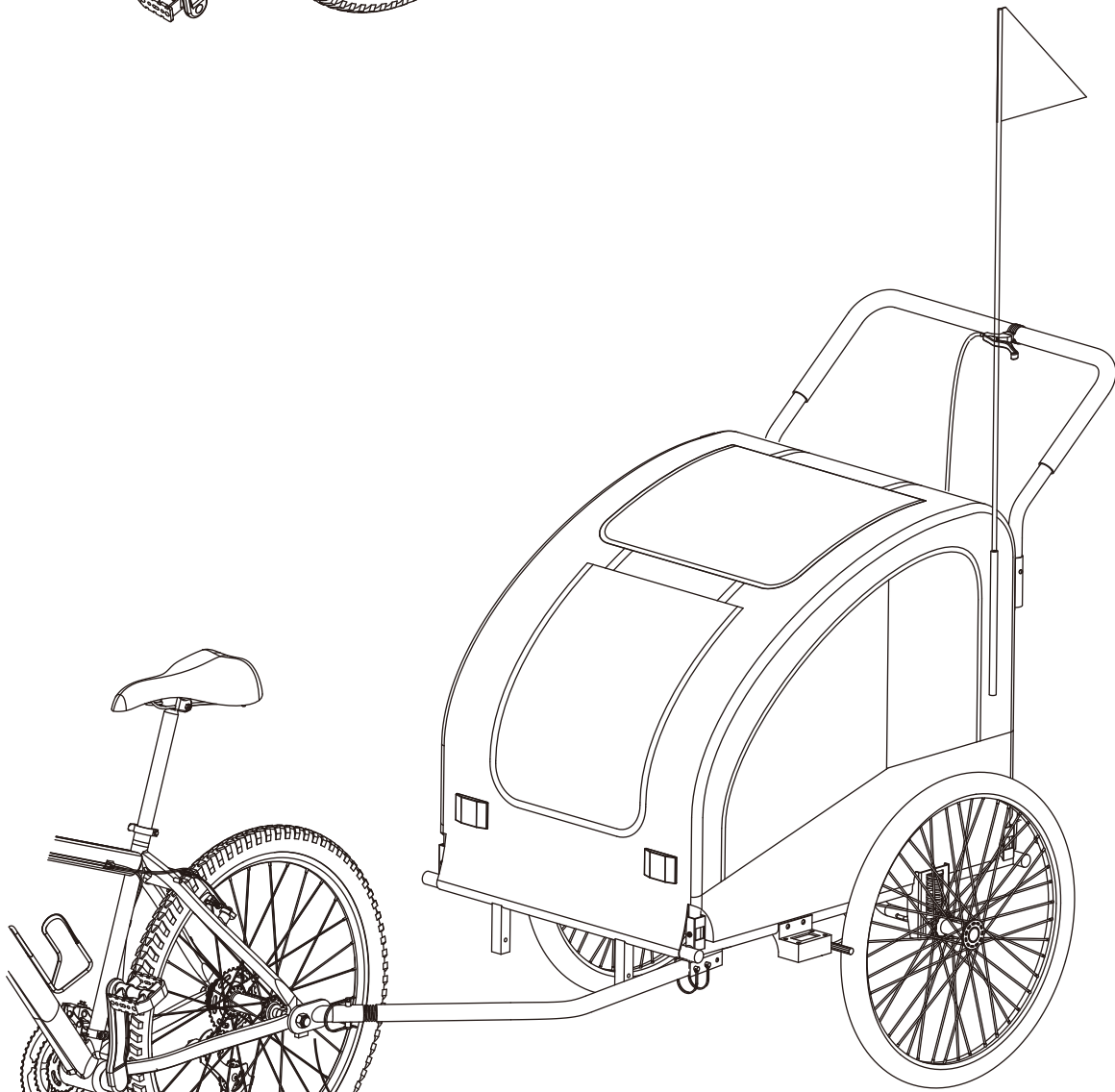
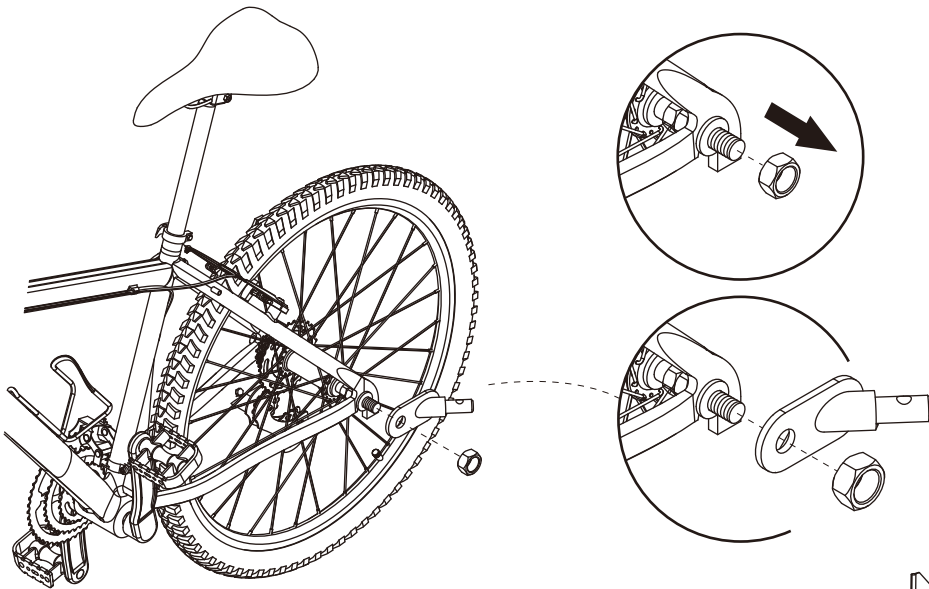

DIFFERENT COMBINATIONS

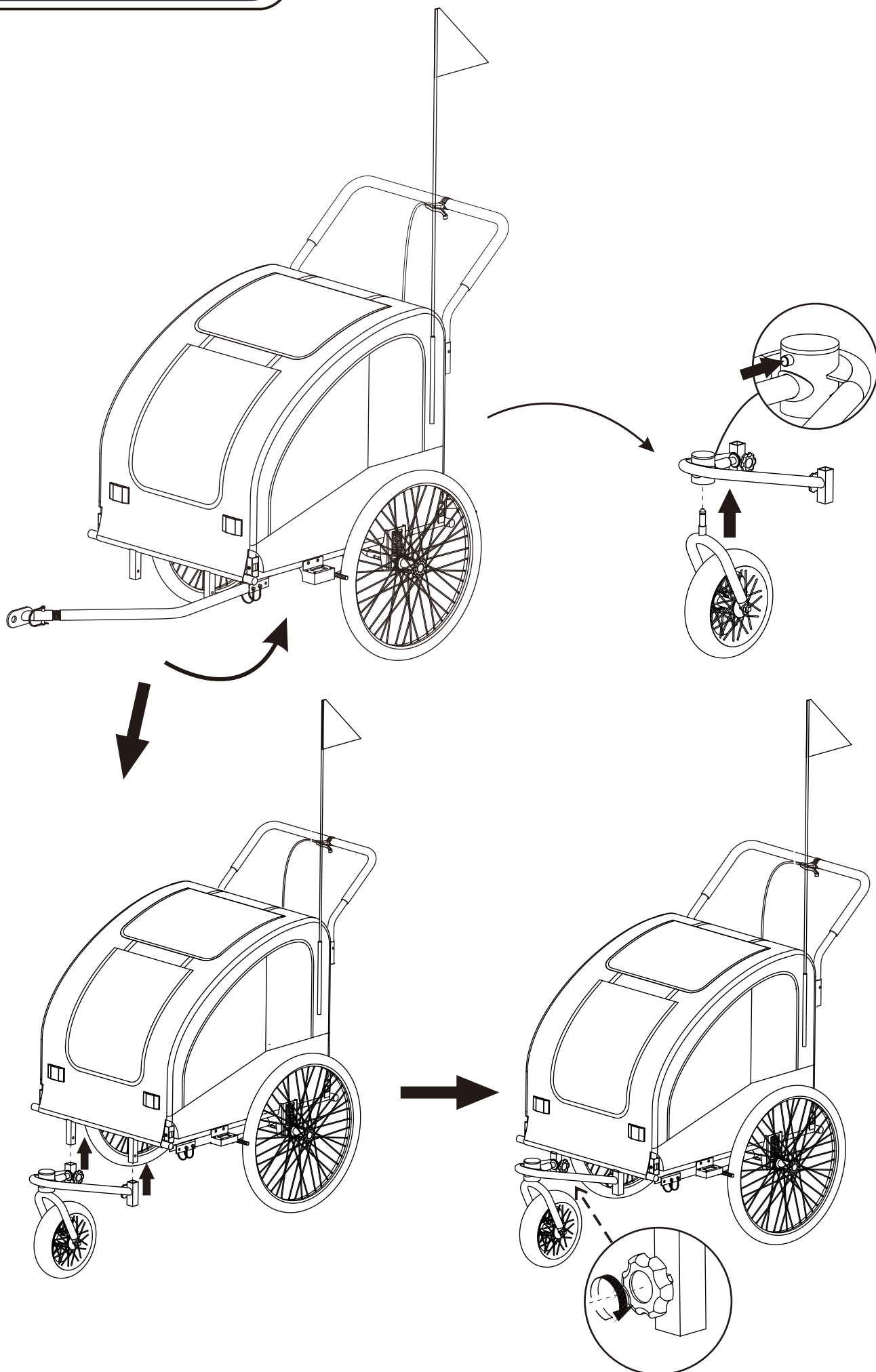

If you have any questions, please contact our customer care center, Our contact details are below:

US

 001-877-644-9366

 customerservice@aosom.com

Imported by Aosom LLC
7777 Center Ave. Suite 430
Huntington Beach, CA 92647-9998 USA

If you have any questions, please contact our customer care center, Our contact details are below:

CA

 416-792-6088

 customerservice@aosom.ca

Imported by Aosom Canada Inc.
7270 Woodbine Avenue, Unit 307, Markham,
Ontario Canada L3R 4B9
MADE IN CHINA

Si vous avez la moindre question, veuillez contacter notre centre d'assistance à la clientèle, Nos coordonnées sont les suivantes:

 416-792-6088

 customerservice@aosom.ca

Importé par Aosom Canada Inc.
7270 Woodbine Avenue, unité 307,
Markham, Ontario Canada L3R 4B9
FABRIQUÉ EN CHINE

Si tiene alguna pregunta, comuníquese con nuestro Centro de Atención al Cliente, Nuestros datos de contacto son los siguientes:

ES

 0034-931294512

 atencioncliente@aosom.es

IMPORTADOR/Fabricante/REP:
SPANISH AOSOM, S.L.
C/ROC GROS, N°15.08550, ELS HOSTALETS DE
BALENYÀ, SPAIN.
B66295775
HECHO EN CHINA

Se tiver alguma dúvida, por favor contacte o nosso Centro de Atendimento ao Cliente, Os nossos dados de contacto são os seguintes:

 0034-931294512

 info@aosom.pt.

IMPORTADOR/Fabricante/REP:
SPANISH AOSOM, S.L.
C.ROC GROS N.15, 08550. ELS HOSTALETS DE
BALENYÀ
FEITO NA CHINA

In caso di dubbio, si prega di contattare il nostro centro assistenza clienti, I nostri dettagli di contatto sono di seguito:

IT

 0039-0249471447

 clienti@aosom.it

IMPORTATO DA/Produttore/REP:
AOSOM Italy srl
Centro Direzionale Milanofiori
Strada 1 Palazzo F1
20057 Assago (MI)
P.I.: 08567220960
FATTO IN CINA

If you have any questions, please contact our customer care center, Our contact details are below:

UK

 0044-800-240-4004

 enquiries@mhstar.co.uk

IMPORTER ADDRESS:
MH STAR UK Ltd
1 Northampton Cross Logistics Park
Northampton Cross Road
Northampton
NN4 9FH
MADE IN CHINA

Wenn Sie Fragen haben, wenden Sie sich bitte an unser Kundendienstzentrum, Unsere Kontaktdaten stehen unten:

DE

 0049-0(40)-87408465

 service@aosom.de

ADRESSE DES IMPORTEURE/Hersteller/REP:
MH Handel GmbH
Wendenstraße 309
D-20537 Hamburg
Germany
IN CHINA HERGESTELLT

Si vous avez la moindre question, veuillez contacter notre centre d'assistance à la clientèle, Nos coordonnées sont les suivantes:

FR

 0033-1-84166106

 aosom@mhfrance.fr

Importé par/Fabricant/REP:
MH FRANCE
2 Rue Maurice Hartmann
92130 Issy Les Moulineaux
France
FABRIQUÉ EN CHINE



FR

**DONNEZ
OU
RECYCLEZ**



ASSOCIATION

OU



LIVRAISON

OU



DÉCHÈTERIE

Adresses sur quefairedemesdechets.fr