

# AIYAPLAY

IN251200533V01\_UK\_DE\_FR\_ES\_PT\_IT

**311-119V80**

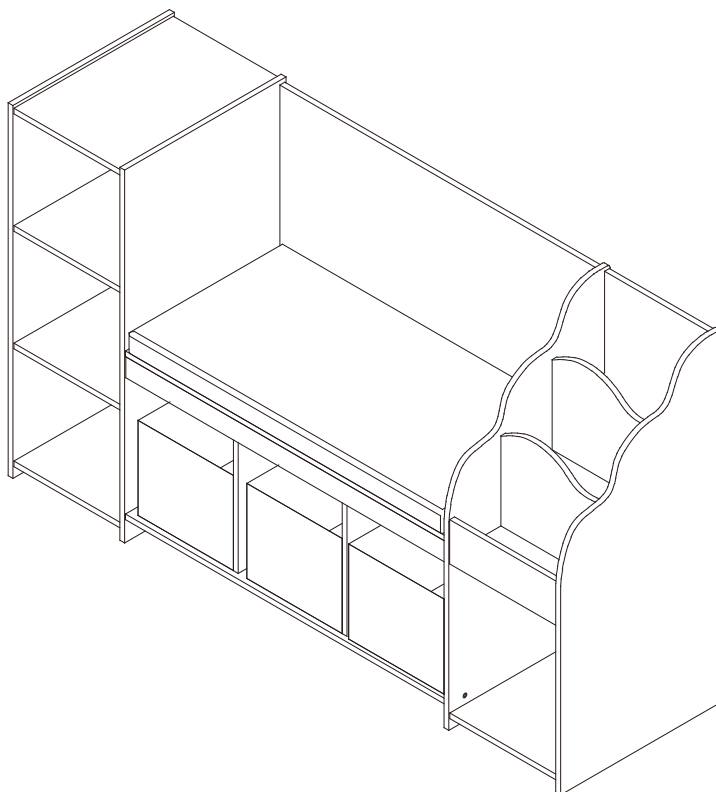

**EN\_WARNING:** Suitable for ages 3 years+; Maximum Weight Capacity: 50 kg.

**FR\_ATTENTION:** Convient aux enfants de 3 ans+; Poids maximum admissible: 50 kg.

**DE\_ACHTUNG:** Geeignet für Kinder im Alter von 3 Jahren+; Max. Gewicht: 50 kg.

**ES\_ADVERTENCIA:** Adecuado para los niños de 3 años+; Carga máxima: 50 kg.

**PT\_ADVERTÊNCIA:** Idade de certificação: 3 anos+; Peso máximo de carga: 50kg.

**IT\_AVVERTENZA:** Adatto a bambini di 3 anni+; Capacità massima: 50 kg.

**EN\_IMPORTANT, RETAIN FOR FUTURE REFERENCE: READ CAREFULLY.**

**FR\_IMPORTANT: A LIRE ATTENTIVEMENT ET À CONSERVER POUR CONSULTATION ULTÉRIEURE.**

**ES\_IMPORTANTE, LEA Y GUARDE PARA FUTURAS REFERENCIAS.**

**PT\_IMPORTANTE, RETER PARA REFERÊNCIA FUTURA: LEIA ATENTAMENTE.**

**DE\_WICHTIG! SORGFÄLTIG LESEN UND FÜR SPÄTER NACHSCHLAGEN AUFBEWAHREN.**

**IT\_IMPORTANTE! CONSERVARE IL PRESENTE MANUALE PER FUTURO RIFERIMENTO E LEGGERLO ATTENTAMENTE.**

# IMPORTANT! READ CAREFULLY AND KEEP FOR FUTURE REFERENCE.

## WARNING:

1. CHOKING HAZARD—Small parts. Not for children under 3 years.
2. Assembly to be carried out by a competent adult only.
3. During assembly children should be kept away from the product due to possible risk of injury.
4. To be used under the direct supervision of an adult.
5. Place it on a flat and clean floor, Check all the parts are well connected before use.
6. DO NOT place this product near a window as it can be used as a step by the child and cause the child to fall out of the window.
7. Be aware of the risk of open fires and other sources of strong heat in the vicinity of the product.
8. DO NOT place this product near a window where cords from blinds or curtains could strangle a child.
9. DO NOT to use the seating if any part is broken, torn or missing and use only spare parts approved by the manufacturer.
10. All assembly fittings should always be tightened properly.
11. Regularly check all fastenings to ensure that they properly tightened.

## MAINTENANCE & CARE

- A. Keep all instructions and parts relating to this product for future reference.
- B. Wood: regularly dust with a clean, soft and dry cloth.
- C. Do not use any abrasive or acidic products. Never use cleaning solvents.  
Professional cleaning only.

# IMPORTANT ! À LIRE ATTENTIVEMENT ET À CONSERVER EN VUE D'UNE CONSULTATION ULTRIEURE.

## ATTENTION:

1. RISQUE D'ÉTOUFFEMENT - Petites pièces. Déconseillé aux enfants de moins de 3 ans.
2. Montage à effectuer uniquement par un adulte compétent.
3. Pendant l'assemblage, les enfants doivent être tenus à l'écart du produit en raison d'un risque de blessure possible.
4. À utiliser sous la surveillance directe d'un adulte.
5. Posez-le sur un sol plat et propre. Vérifiez que toutes les pièces sont bien connectés avant toute utilisation.
6. NE PAS placer ce produit près d'une fenêtre ; il pourrait être utilisé comme marchepied par un enfant et le faire tomber par la fenêtre.
7. Soyez conscient du risque de feu ouvert et d'autres sources de forte chaleur à proximité du produit.
8. NE PAS placer ce produit près d'une fenêtre où les cordons des stores ou des rideaux pourraient étrangler un enfant.
9. NE PAS utiliser le siège si une pièce est cassée, déchirée ou manquante et n'utiliser que des pièces de rechange approuvées par le fabricant.
10. Tous les accessoires de montage doivent toujours être correctement serrés.
11. Vérifiez régulièrement toutes les fixations pour vous assurer qu'elles sont correctement serrées.

## ENTRETIEN ET MAINTENANCE

- A. Conservez toutes les instructions et les pièces relatives à ce produit pour pouvoir vous y référer ultérieurement.
- B. Bois : Dépoussiérer régulièrement avec un chiffon propre, doux et sec.
- C. Proscrire tout abrasif et produits acides. Ne jamais employer de solvants.



Adresses sur [quefairedemesdechets.fr](http://quefairedemesdechets.fr)

# WICHTIG! SORGFÄLTIG LESEN UND FÜR KÜNFTIGES NACHLESEN AUFBEWAHREN.

## ACHTUNG:

1. ERSTICKUNGSGEFAHR-Kleine Teile. Nicht für Kinder unter 3 Jahren geeignet.
2. Die Montage darf nur von einer kompetenten erwachsenen Person durchgeführt werden.
3. Während der Montage sollten Kinder vom Produkt ferngehalten werden, da Verletzungsgefahr besteht.
4. Es ist unter der direkten Aufsicht eines Erwachsenen zu verwenden.
5. Stellen Sie es auf einen flachen und sauberen Boden. Prüfen Sie, ob alle Teile vor der Verwendung gut verbunden sind.
6. Stellen Sie dieses Produkt NICHT in der Nähe eines Fensters auf, da es vom Kind als Stufe verwendet werden und das Kind dadurch aus dem Fenster fallen kann.
7. Seien Sie sich der Gefahr von offenem Feuer und anderen starker Wärmequellen nahe des Produkts bewusst.
8. Stellen Sie dieses Produkt NICHT in der Nähe eines Fensters auf, wo die Schnüre von Jalousien oder Vorhängen ein Kind erdrosseln könnten.
9. Verwenden Sie den Sitz NICHT, wenn ein Teil gebrochen ist, gerissen ist oder fehlt und verwenden Sie nur vom Hersteller zugelassene Ersatzteile.
10. Alle Montageteile sollten immer richtig festgezogen sein.
11. Überprüfen Sie regelmäßig alle Befestigungen, um sicherzustellen, dass sie richtig angezogen sind.

## WARTUNG & PFLEGE

- A. Bewahren Sie alle Anweisungen und Teile, die sich auf dieses Produkt beziehen, zur späteren Verwendung auf.
- B. Holz: Regelmäßig mit einem sauberen, weichen und trockenen Tuch abstauben.
- C. Keinesfalls abrasive und ätzende Reinigungsprodukte anwenden. Verwenden Sie niemals Lösungsmittel.

# **IMPORTANTE! LEGGERE ATTENTAMENTE E CONSERVARE PER RIFERIMENTO FUTURO.**

## **AVVERTENZE:**

1. **RISCHIO DI SOFFOCAMENTO** — Parti piccole. Non adatte a bambini sotto i 3 anni.
2. L'assemblaggio deve essere effettuato esclusivamente da un adulto competente.
3. Durante l'assemblaggio i bambini devono essere tenuti lontani dal prodotto a causa del possibile rischio di lesioni.
4. Da utilizzare sotto la diretta supervisione di un adulto.
5. Posizionarlo su una superficie piana e pulita, controllare che tutte le parti siano connesse correttamente prima dell'uso.
6. **NON** posizionare il prodotto vicino a una finestra, poiché potrebbe essere utilizzato come gradino dal bambino e causarne la caduta dalla finestra.
7. Stare attento al rischio di fuochi e di altre fonti di forte calore nelle vicinanze del prodotto.
8. **NON** posizionare il prodotto vicino a una finestra dove le corde delle tende o delle tapparelle potrebbero strangolare il bambino.
9. **NON** utilizzare il seggiolino se qualche parte è rotta, strappata o mancante e utilizzare solo ricambi approvati dal produttore.
10. Tutti i componenti di assemblaggio devono essere sempre serrati correttamente.
11. Controllare regolarmente tutti i fissaggi per assicurarsi che siano adeguatamente serrati.

## **MANUTENZIONE & CURA**

- A. Conservare tutte le istruzioni e le parti relative a questo prodotto per riferimenti futuri.
- B. Legno: spolverare regolarmente con un panno pulito, morbido e asciutto.
- C. Non usare prodotti abrasivi o acidi. Non usare mai solventi.

# ¡IMPORTANTE! LEA CUIDADOSAMENTE Y GUARDE PARA LAS REFERENCIAS FUTURAS.

## ADVERTENCIA:

1. PELIGRO DE ASFIXIA: Incluidas piezas pequeñas. No es adecuado para los niños menores de 3 años.
2. El montaje debe ser realizado únicamente por un adulto competente.
3. Durante el montaje, los niños deben mantenerse alejados del producto debido al posible riesgo de lesiones.
4. El producto debe ser utilizado bajo la supervisión directa de un adulto.
5. Colóquelo sobre un piso plano y limpio. Verifique si todas las piezas estén conectadas adecuadamente antes de utilizarlo.
6. NO coloque este producto cerca de ventanas, de lo contrario, los niños pueden utilizarlo como un escalón y hacer que se caigan por la ventana.
7. Tenga en cuenta el riesgo de llamas abiertas y otras fuentes de calor intenso cerca del producto.
8. NO coloque este producto cerca de ventanas, ya que los cordones de las persianas o las cortinas puedan estrangular a los niños.
9. NO utilice el asiento si alguna pieza está dañada, rasgada o faltante, y utilice únicamente los repuestos aprobados por el fabricante.
10. Todos los accesorios de montaje deben estar siempre bien apretados.
11. Revise periódicamente todas las fijaciones para asegurarse de que están correctamente apretadas.

## MANTENIMIENTO Y CUIDADO

- A. Guarde todas las instrucciones y piezas relativas juntas con este producto para las referencias futuras.
- B. Madera: quitar el polvo regularmente con un paño limpio, suave y seco.
- C. No utilice productos abrasivos o ácidos. No utilice nunca disolventes de limpieza. Sólo se debe realizar una limpieza profesional.

# IMPORTANTE! LER ATENTAMENTE E GUARDAR PARA REFERÊNCIA FUTURA.

## ADVERTÊNCIA:

1. PERIGO DE ASFIXIA: Incluí peças pequenas. Não adequado para crianças com menos de 3 anos de idade.
2. Montagem a ser realizada apenas por um adulto competente.
3. Durante a montagem, as crianças devem ser mantidas afastadas do produto devido ao possível risco de lesões.
4. O produto deve ser utilizado sob a supervisão directa de um adulto.
5. Colocá-lo sobre um chão plano e limpo. Verificar se todas as peças estão devidamente conectadas antes da sua utilização.
6. NÃO coloque este produto perto de janelas, caso contrário as crianças podem usá-lo como um degrau e fazê-las cair da janela.
7. Estar consciente do risco de chamas abertas e outras fontes de calor intenso perto do produto.
8. NÃO coloque este produto perto de janelas, pois os cordões das persianas ou cortinas podem sufocar as crianças.
9. NÃO utilizar o assento se alguma peça estiver danificada, rasgada ou em falta, e utilizar apenas peças de substituição aprovadas pelo fabricante.
10. Todos os acessórios de montagem devem estar sempre devidamente apertados.
11. Verifique regularmente todas as fixações para garantir que estejam devidamente apertadas.

## MANUTENÇÃO E CUIDADOS

- A. Manter todas as instruções e peças relacionadas com este produto em guardadas para referência futura.
- B. Madeira: Pó regularmente com um espanador limpo, macio e seco.
- C. Proibir qualquer esfregão e produtos ácidos. Nunca utilizar solvente de limpeza. Apenas limpeza profissional.

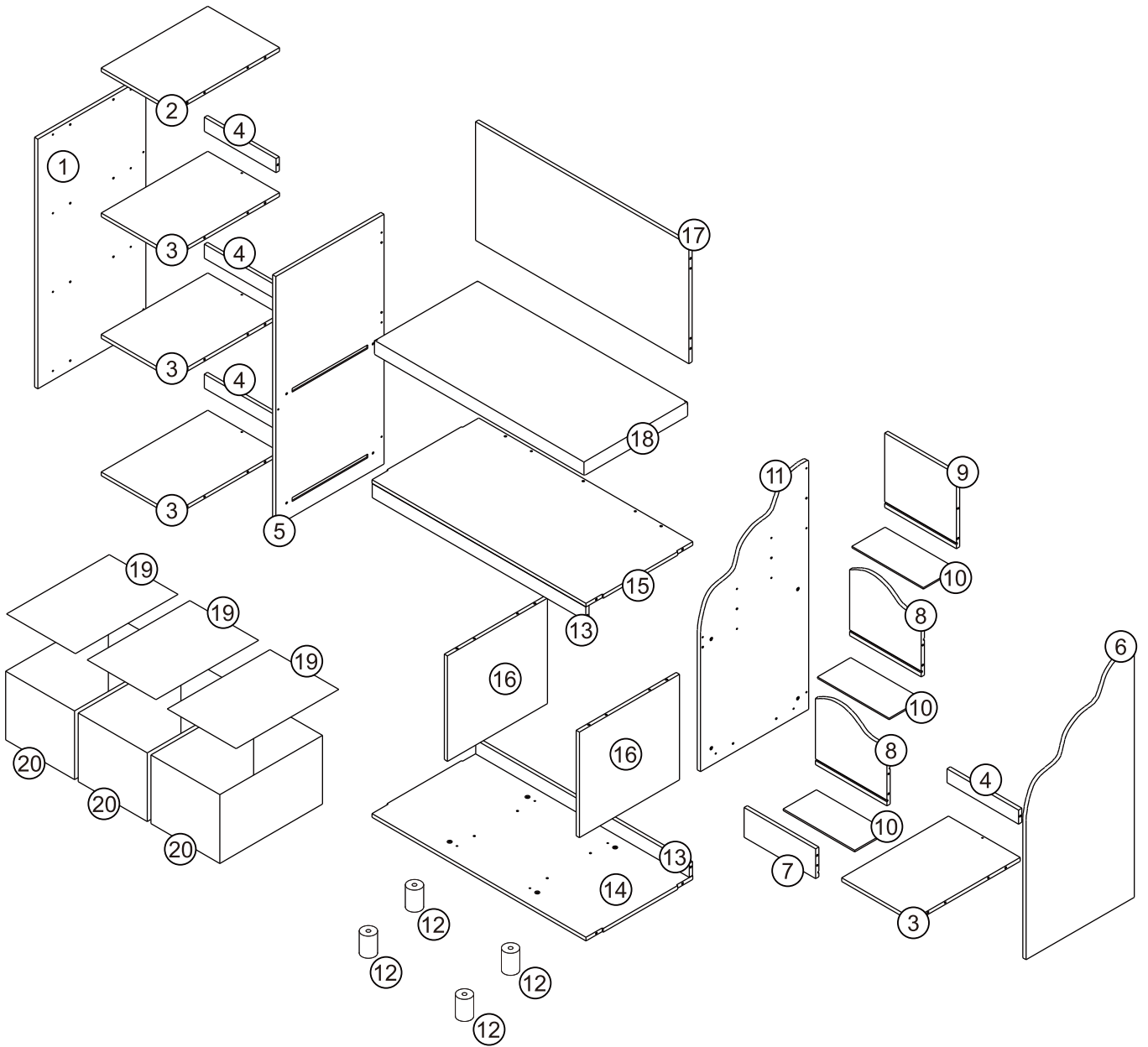

① x1

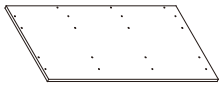

② x1

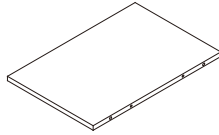

③ x4

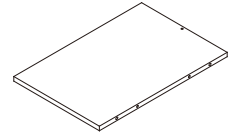

④ x4

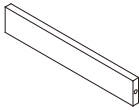

⑤ x1

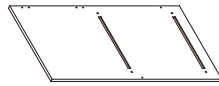

⑥ x1

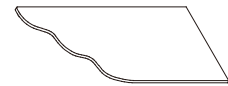

⑦ x1

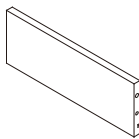

⑧ x2

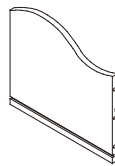

⑨ x1

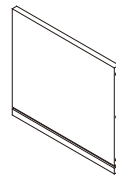

⑩ x3

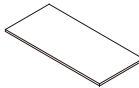

⑪ x1

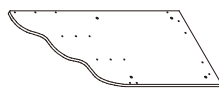

⑫ x4



⑬ x2

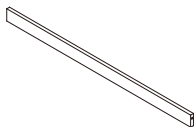

⑭ x1

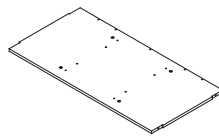

⑮ x1

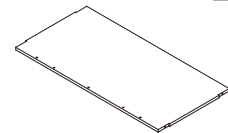

⑯ x2

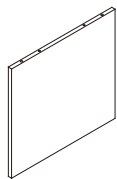

⑰ x1

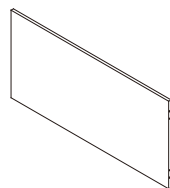

⑱ x1

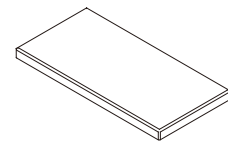

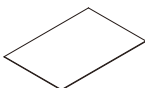

⑲ x3

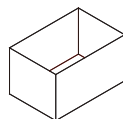

⑳ x3

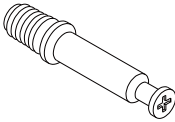
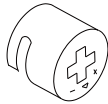
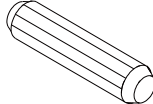
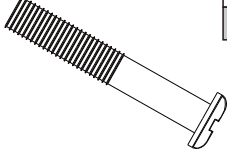
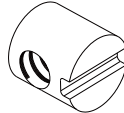
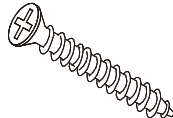
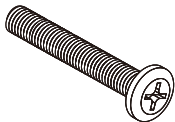
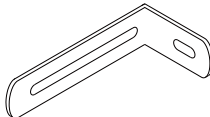
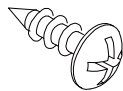
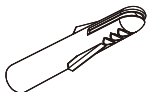

 <p><b>A</b> x64 M6*38 +2(spare)</p>	 <p><b>B</b> x64 Ø12*10 +2(spare)</p>	 <p><b>C</b> x46 Ø6*25 +2(spare)</p>
 <p><b>D</b> x11 M6*40 +1(spare)</p>	 <p><b>E</b> x11 Ø10*10 +1(spare)</p>	 <p><b>F</b> x6 M4*30 +1(spare)</p>
 <p><b>G</b> x4 M6*20 +1(spare)</p>	 <p><b>H</b> x2 66x32x15</p>	 <p><b>I</b> x2 M4*10</p>
 <p><b>J</b> x2 Ø6*30</p>	 <p><b>K</b> x1</p>	

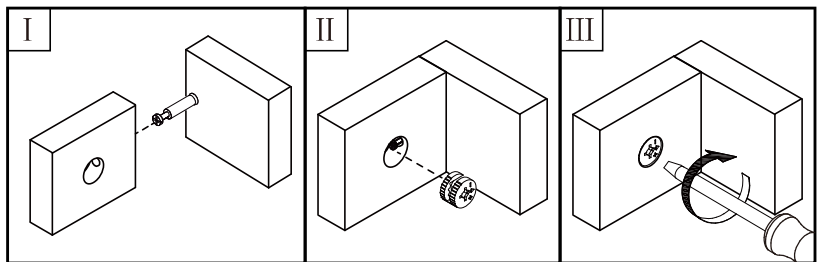
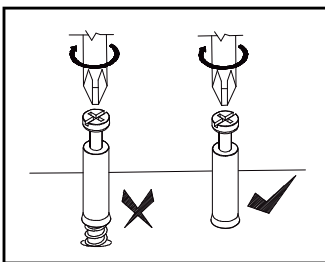

01

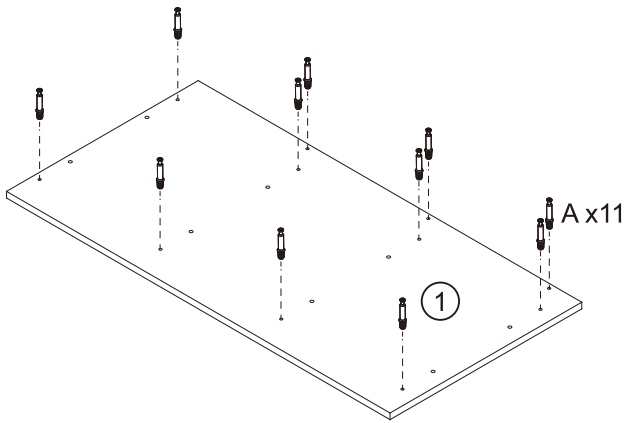

02

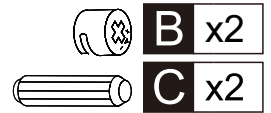
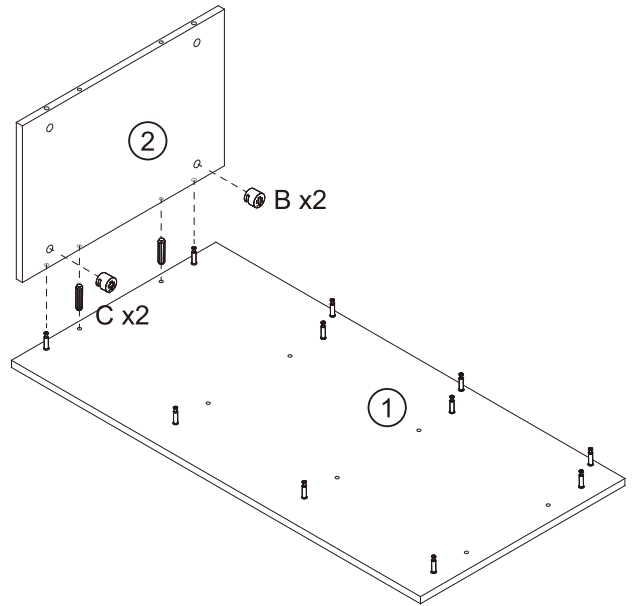

03

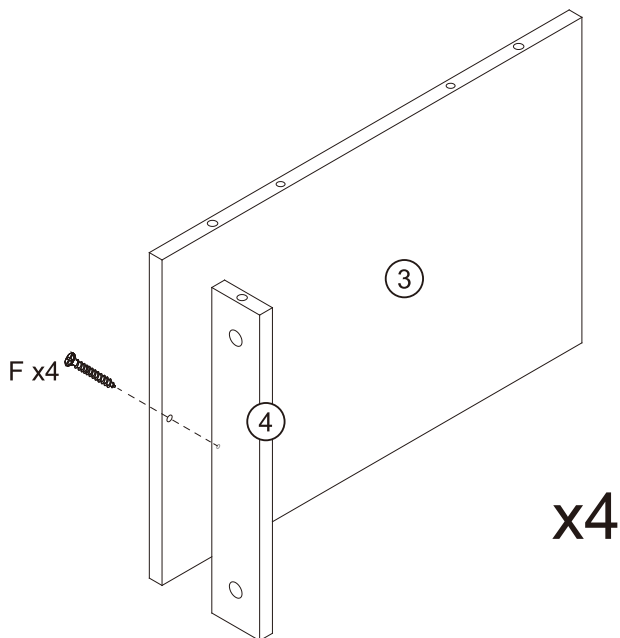

04

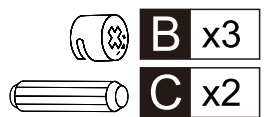
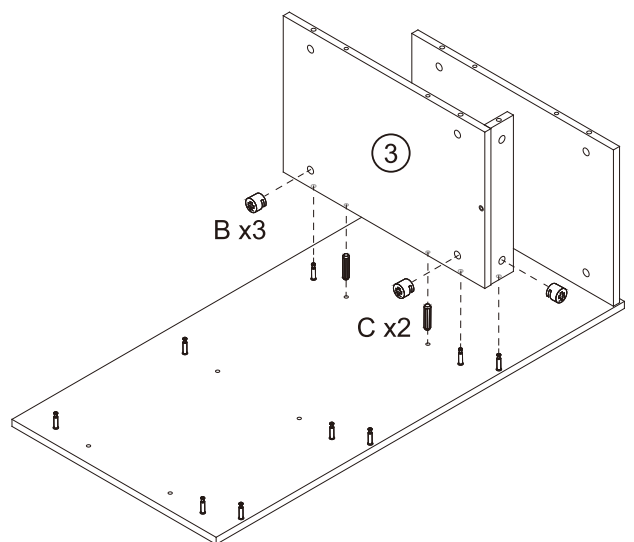

05

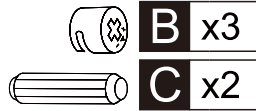
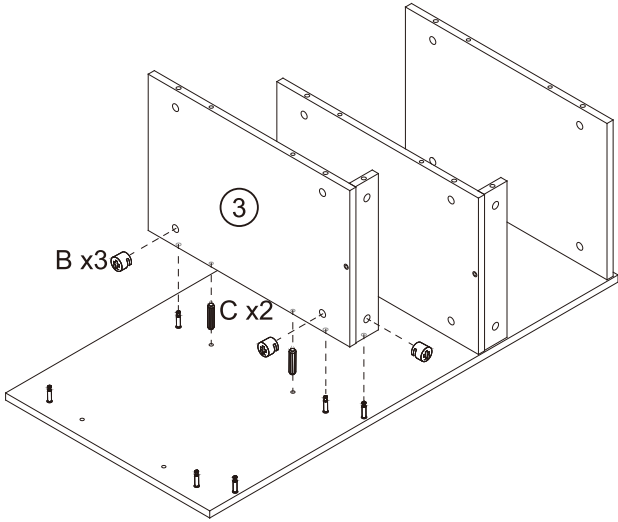

06

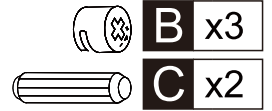
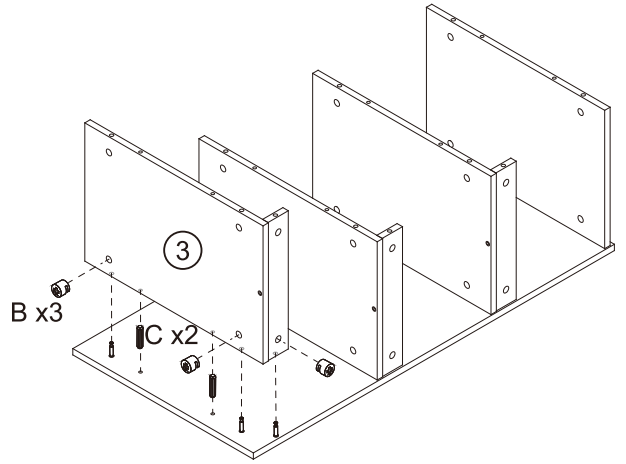

07

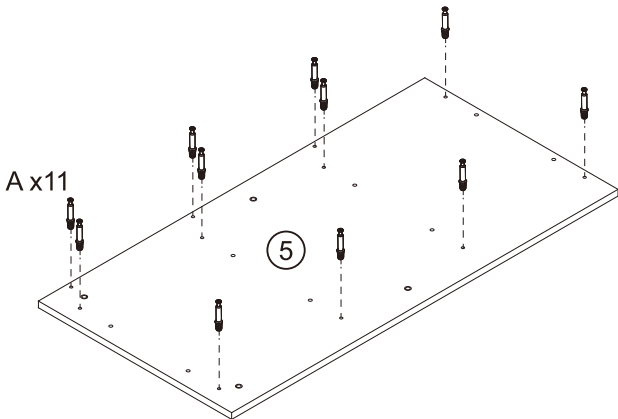

08

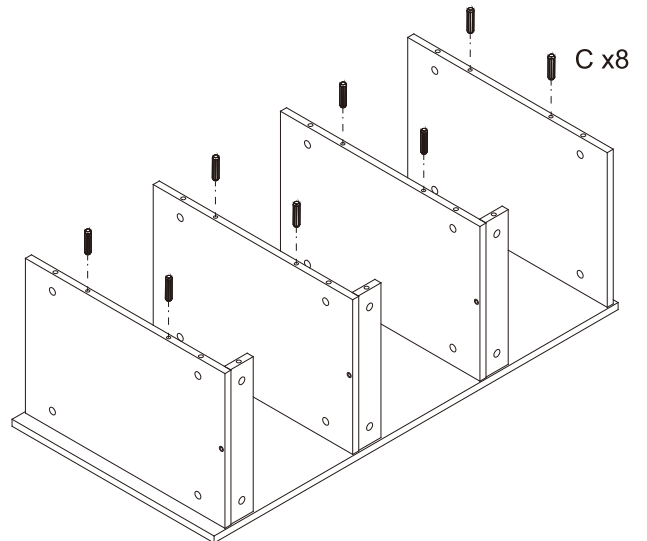

09

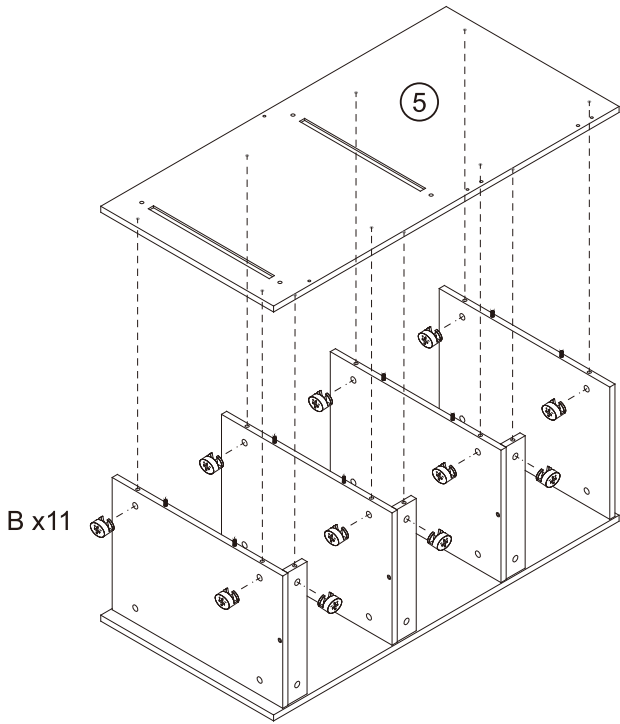

B x11



10

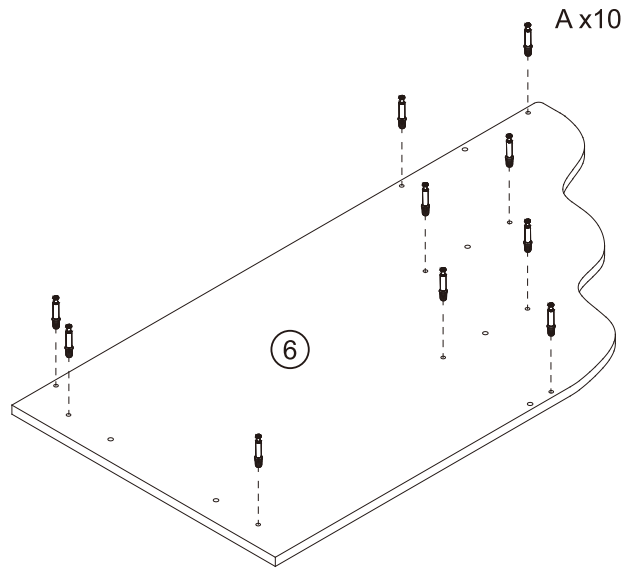

A x10



11

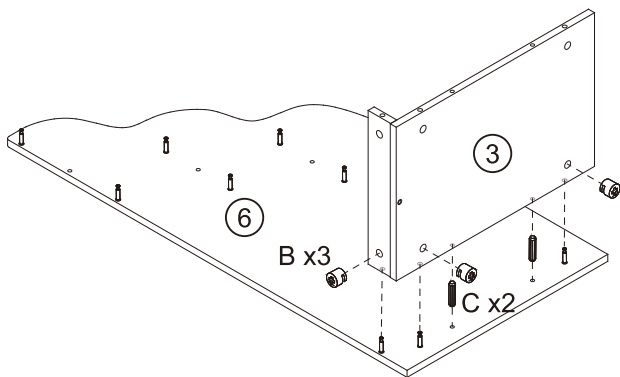

B x3

C x2

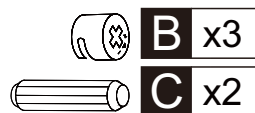

12

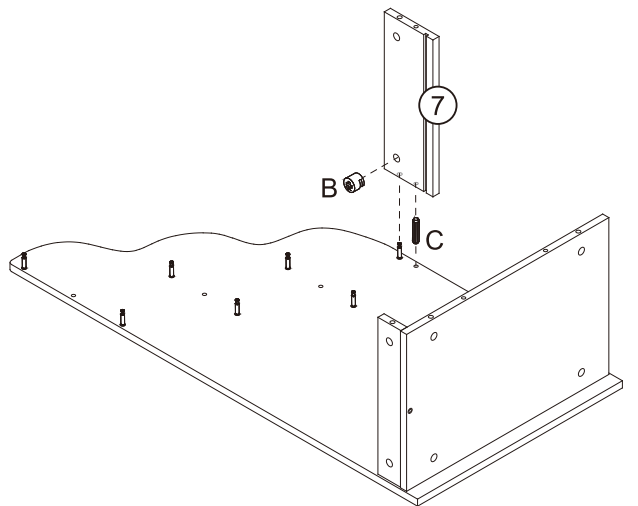

B x1

C

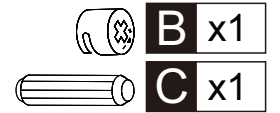

13

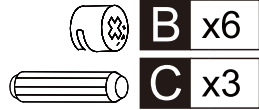
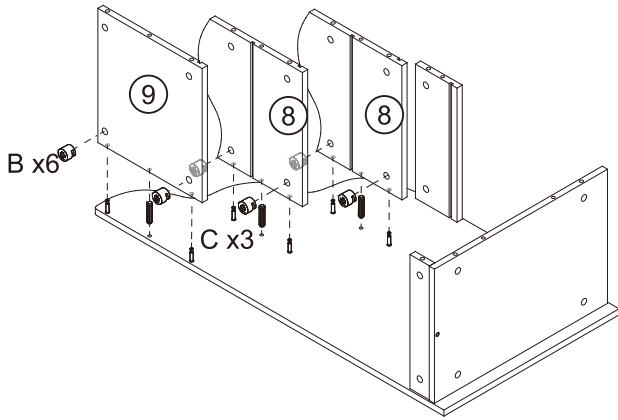

14

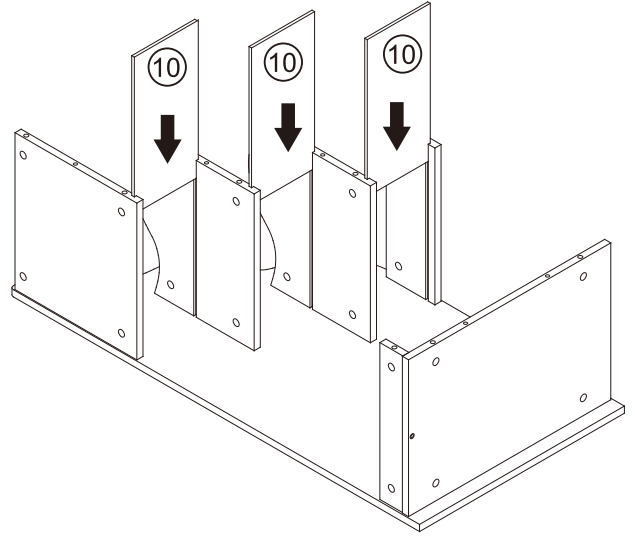

15

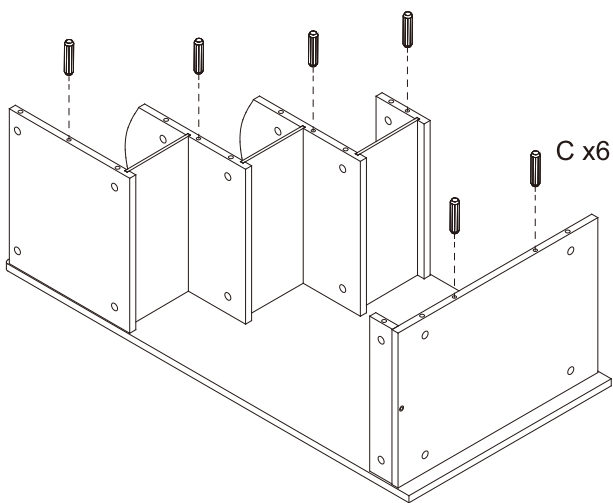

16

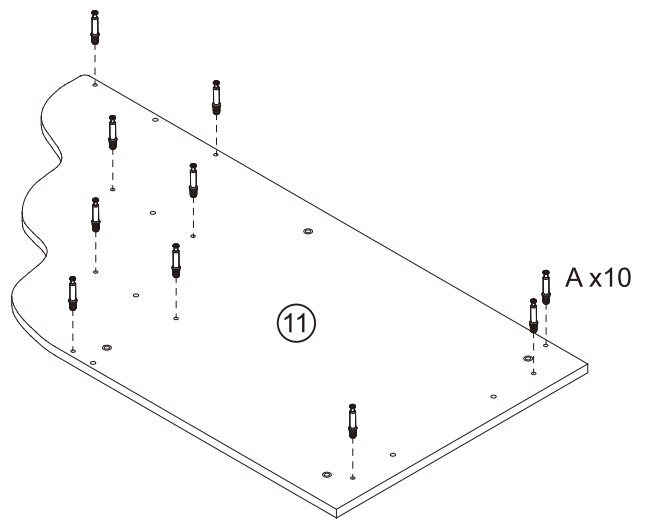

17

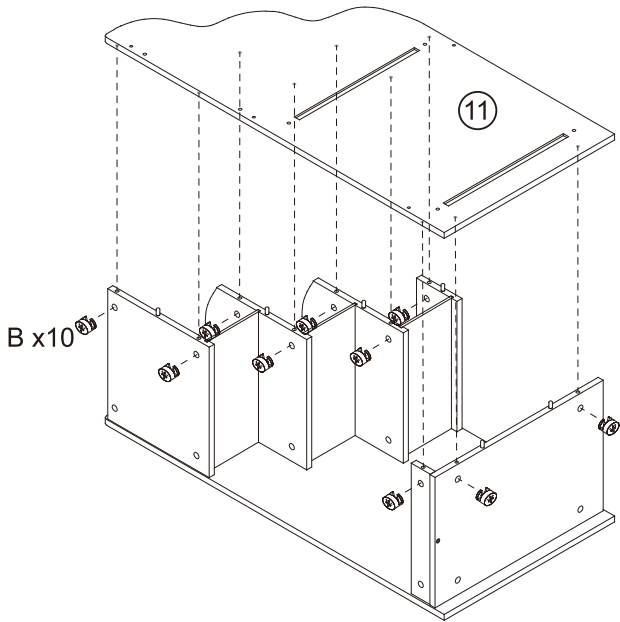

18

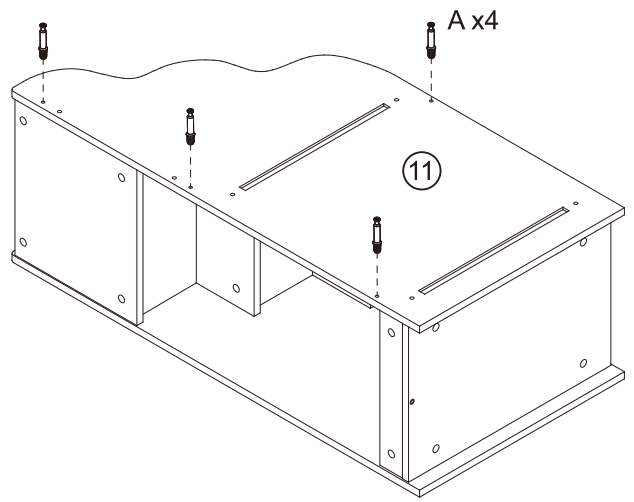

19

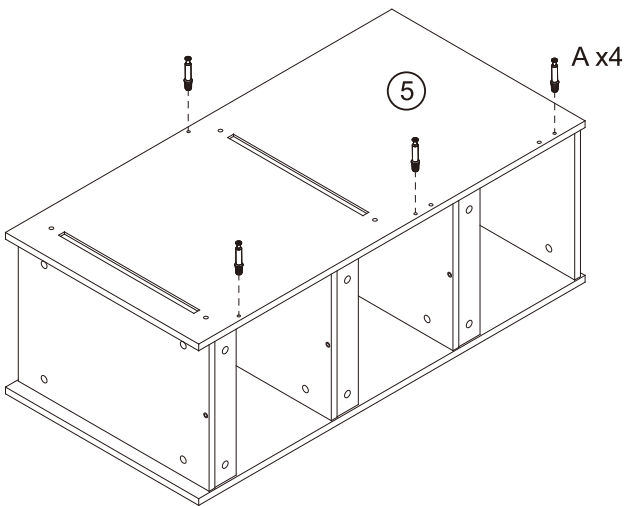

20

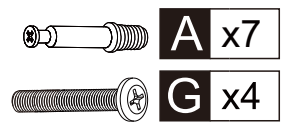
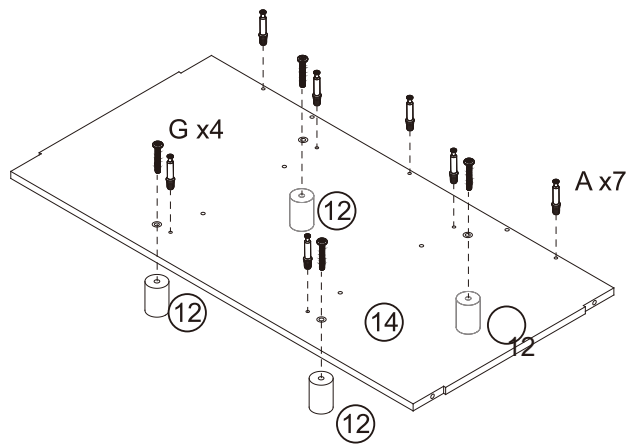

21

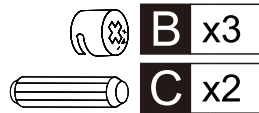
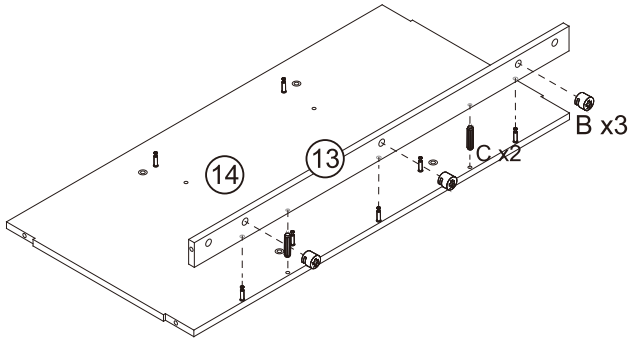

22

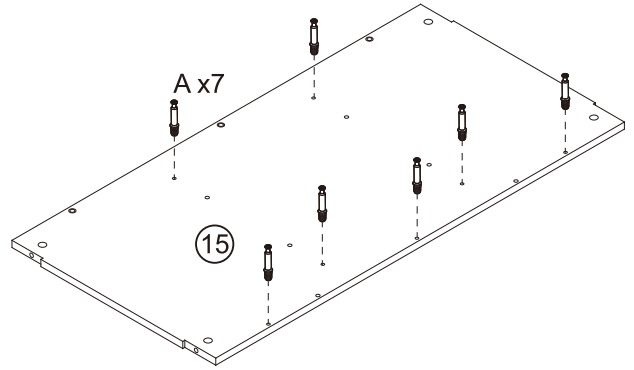

23

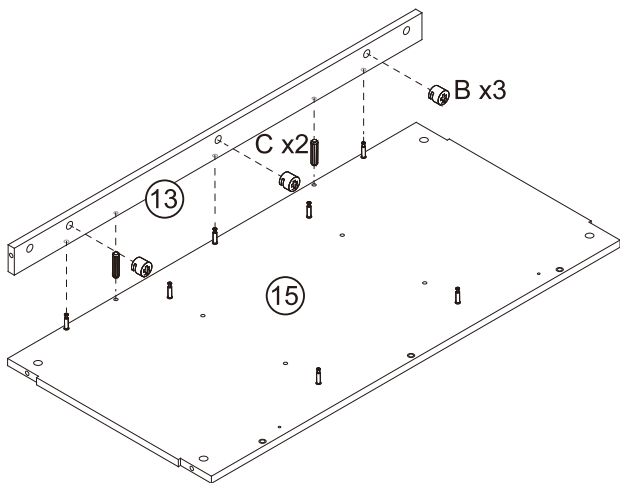

24

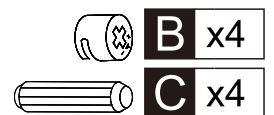
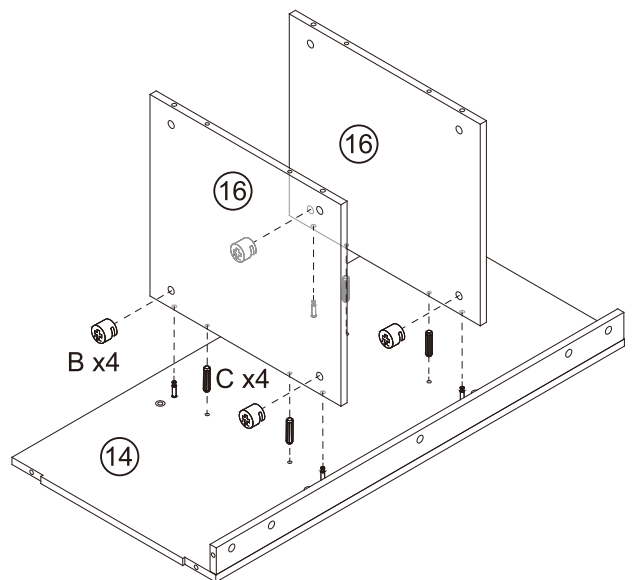

25

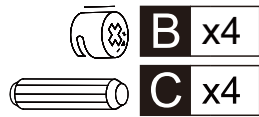
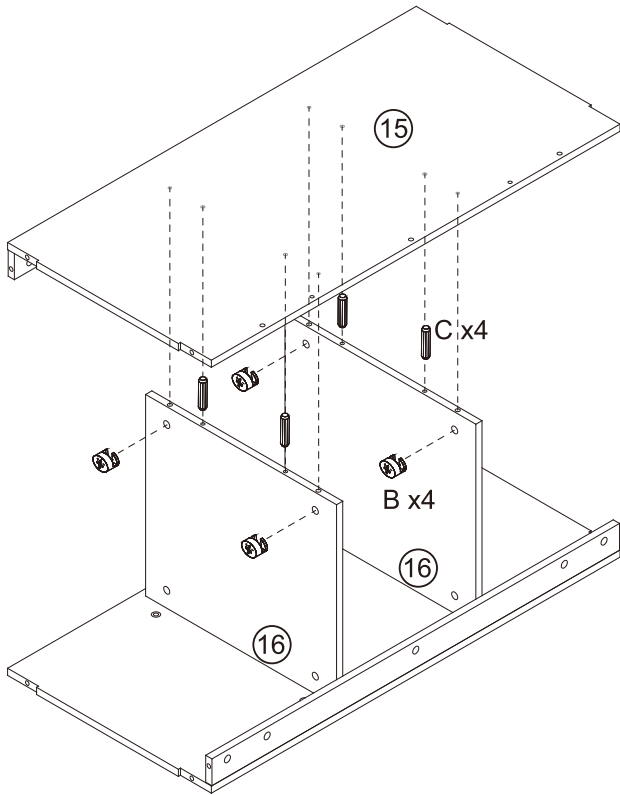

26

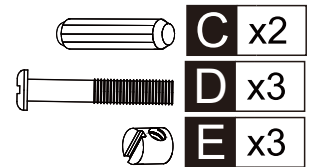
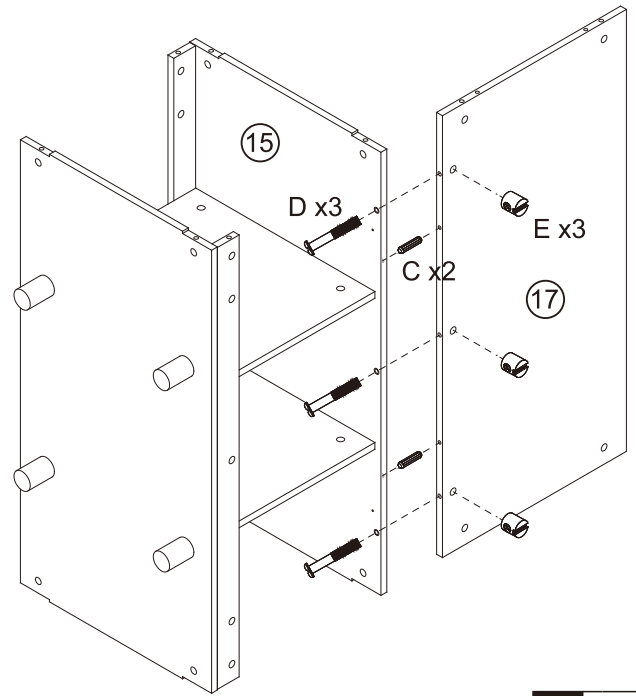

27

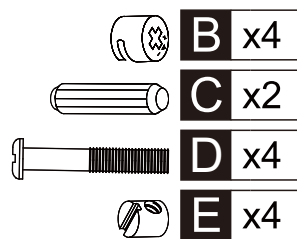
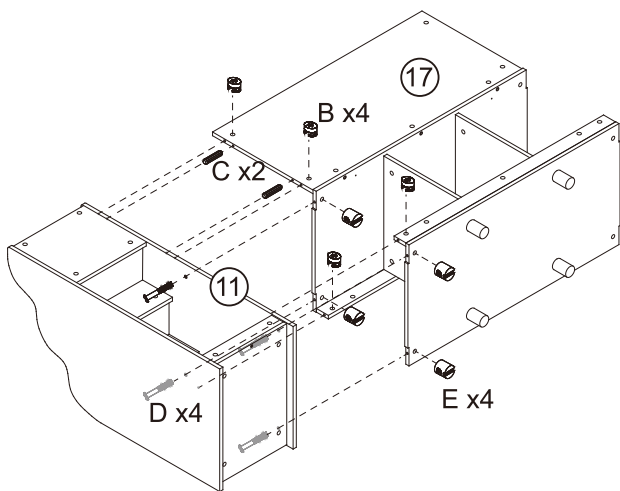

28

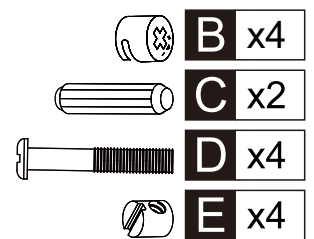
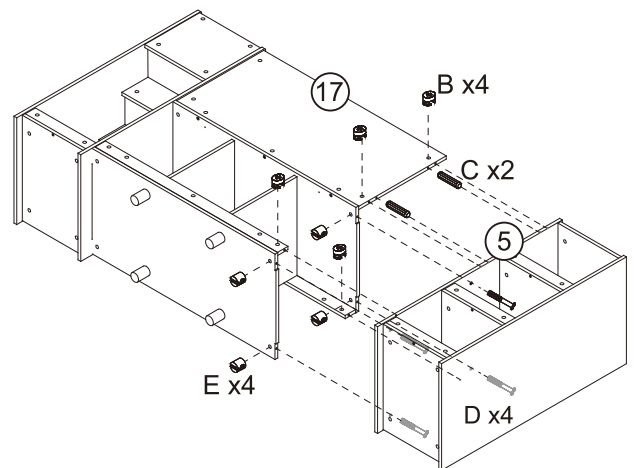

29

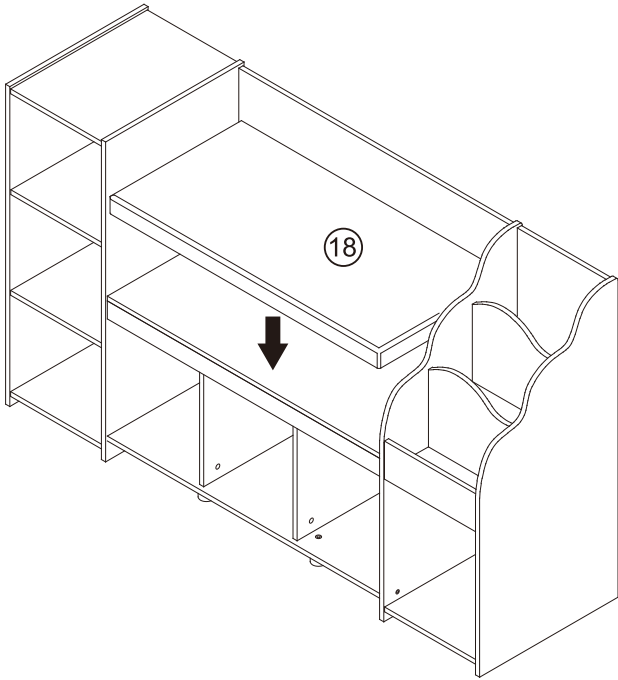

30

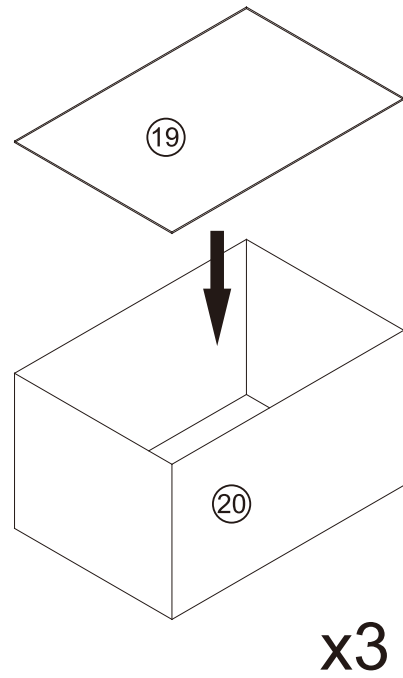



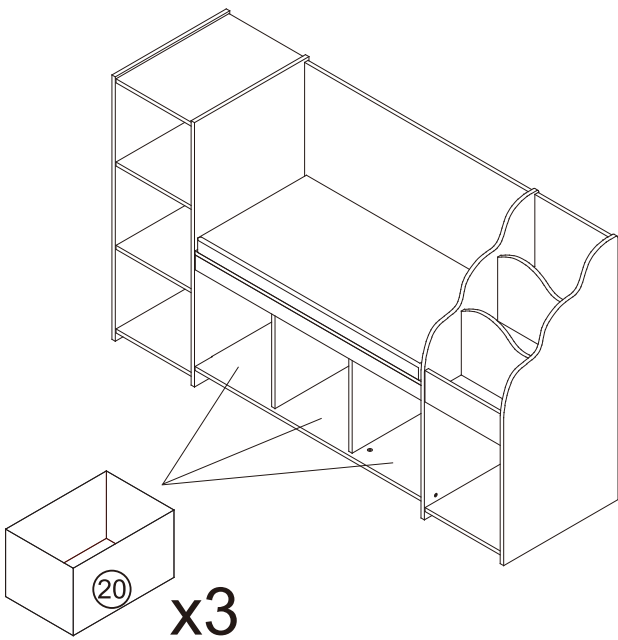

31

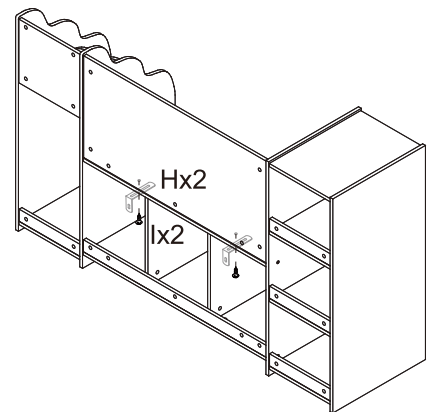
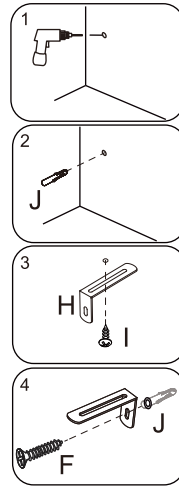

32



-  **F** x2
-  **H** x2
-  **I** x2
-  **J** x2

**UK**

If you have any questions, please contact our customer care centre.

Our contact details are below:



0044-800-240-4004



enquiries@mhstar.co.uk

IMPORTER ADDRESS:

MH STAR UK Ltd  
1 Northampton Cross Logistics Park  
Northampton Cross Road  
Northampton  
NN4 9FH  
MADE IN CHINA

**ES**

Si tiene alguna pregunta, comuníquese con nuestro Centro de Atención al Cliente. Nuestros datos de contacto son los siguientes:



0034-931294512



atencioncliente@aosom.es

Importador/Fabricante/REP:

Spanish Aosom, S.L.  
C/ Roc Gros, nº 15. 08550, Els Hostalets de Balenyà, Spain.  
B66295775  
atencioncliente@aosom.es  
TEL: 931294512  
HECHO EN CHINA

**FR**

Si vous avez la moindre question, veuillez contacter notre centre d'assistance à la clientèle.

Nos coordonnées sont les suivantes:



0033-1-84166106



aosom@mhfrance.fr

Importé par/Fabricant/REP:

MH France  
2, rue Maurice Hartmann  
92130 Issy-les-Moulineaux  
France  
FABRIQUÉ EN CHINE

**PT**

Se tiver alguma dúvida, por favor contacte o nosso Centro de Atendimento ao Cliente. Os nossos dados de contacto são os seguintes:



0034-931294512



info@aosom.pt.

IMPORTADOR:

SPANISH AOSOM, S.L  
C.ROC GROS N.15, 08550. ELS HOSTALETES DE BALENYÀ  
TEL: 931294512 (SEG-SEX DAS 7:30H ÀS 16:30H)  
INFO@AOSOM.PT  
WWW.AOSOM.PT

**DE**

Wenn Sie Fragen haben, wenden Sie sich bitte an unser Kundendienstzentrum.

Unsere Kontaktdaten stehen unten:



0049-0(40)-87408465



service@aosom.de

Importeur/Hersteller/REP:

MH Handel GmbH  
Wendenstraße 309  
D-20537 Hamburg  
Germany  
IN CHINA HERGESTELLT

**IT**

In caso di dubbio, si prega di contattare il nostro centro assistenza clienti. I nostri dettagli di contatto sono di seguito:



0039-0249471447



clienti@aosom.it

IMPORTATO DA/Produttore/REP:

AOSOM Italy srl  
Centro Direzionale Milanofiori  
Strada 1 Palazzo F1  
20057 Assago (MI)  
P.I.: 08567220960  
FATTO IN CINA

