

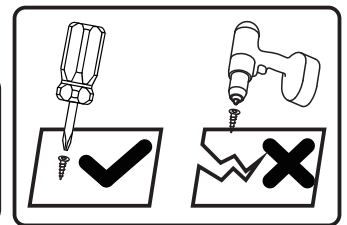

IN251200501V01_GL

837-756V80

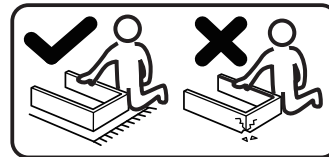
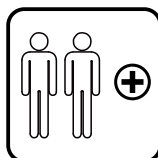
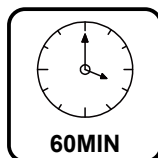
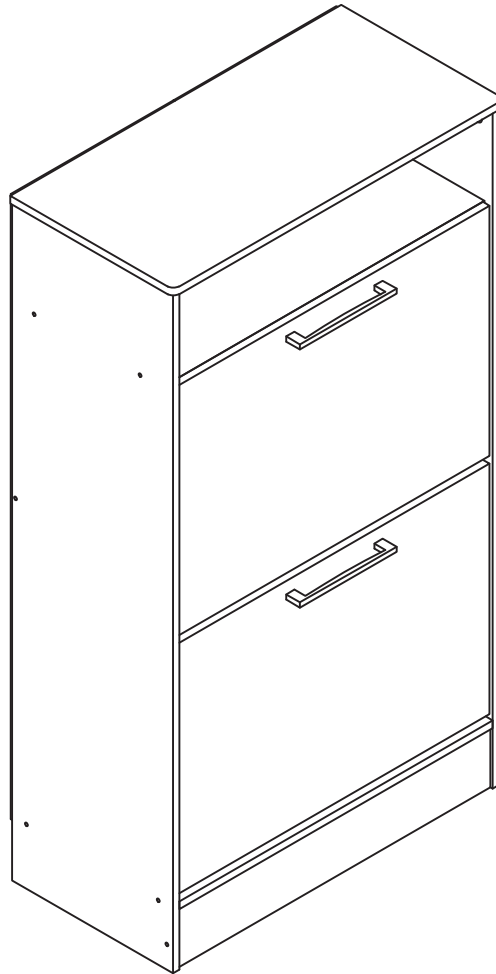

EN_IMPORTANT, RETAIN FOR FUTURE REFERENCE: READ CAREFULLY.

FR_IMPORTANT: A LIRE ATTENTIVEMENT ET A CONSERVER POUR VOUS Y REFRERER ULTERIEUREMENT

ES_IMPORTANTE, LEA DETENIDAMENTE Y GUARDE PARA FUTURAS REFERENCIAS.

PT_IMPORTANTE, GUARDE PARA FUTURA REFERÊNCIA, LEIA ATENTAMENTE.

DE_WICHTIG! SORFGFÄLTIG LESEN UND FÜR SPÄTERES NACHSCHLAGEN AUFBEWAHREN.

IT_IMPORTANTE, LEGGERE E CONSERVARE QUESTO MANUALE D'ISTRUZIONE PER UN USO FUTURO.

IF HAVE THIS ACCESSORY

NOTE DIFFERENT MODELS

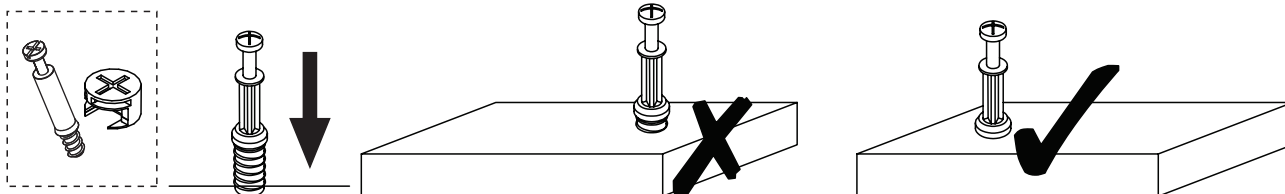

EN_QUICKFIT: Tighten quickfit until shoulder is flush with panel. Do not overtighten or undertighten.

FR_RACCORD RAPIDE: Faites serrer le raccord rapide jusqu'à ce que l'épaulement soit parfaitement encastré dans le panneau. Il ne faut ni trop serrer ni insuffisamment serrer.

ES_QUICKFIT: Apriete quickfit hasta que el hombro se descargue con el panel. NO lo sobreapriete ni lo apriete poco.

PT_AJUSTE RÁPIDO: Aperte o ajuste rápido até estar nivelada com o painel. Não apertar demasiado ou excessivamente.

DE_QUICKFIT: Ziehen Sie den Quickfit fest, bis die Schulter mit der Platte bündig ist. Bitte nicht zu fest oder zu schwach anziehen.

IT_MONTAGGIO RAPIDO: Stringere il montaggio rapido fino a quando la spalla è a filo con il pannello, non stringere troppo o troppo poco.

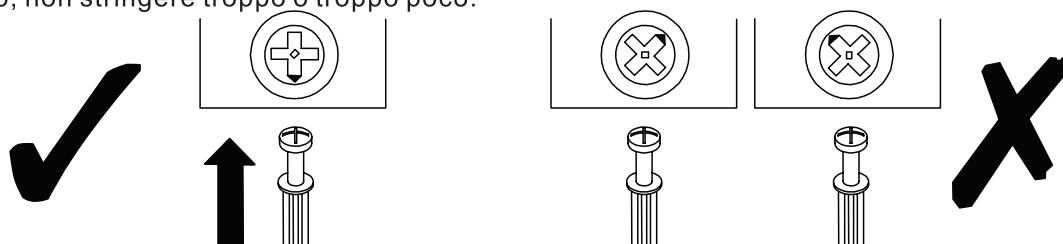

EN_CAM LOCK: When fitting cam lock, ensure starting position is correct before you insert connecting quickfit.

FR_SERRURE BATTEUSE: Avant d'insérer la serrure batteuse, veillez à la bonne orientation avant d'insérer le raccord rapide.

ES_CIERRE DE LA CÁMARA: Cuando instale el cierre de la cámara, asegúrese de que la posición de inicio es correcta antes de que inserte el quickfit conector.

PT_BLOQUEIO: Ao instalar o bloqueio, assegurar-se de que a posição inicial está correcta antes de inserir o encaixe de ligação rápida.

DE_CAM-LOCK: Achten Sie bei der Montage des Cam-Locks auf die richtige Ausgangsposition, bevor Sie den Quickfit einsetzen.

IT_BLOCCAGGIO A CAMMA: Quando si monta il bloccaggio a camma, assicurarsi che la posizione iniziale sia corretta prima di inserire il montaggio rapido di collegamento.

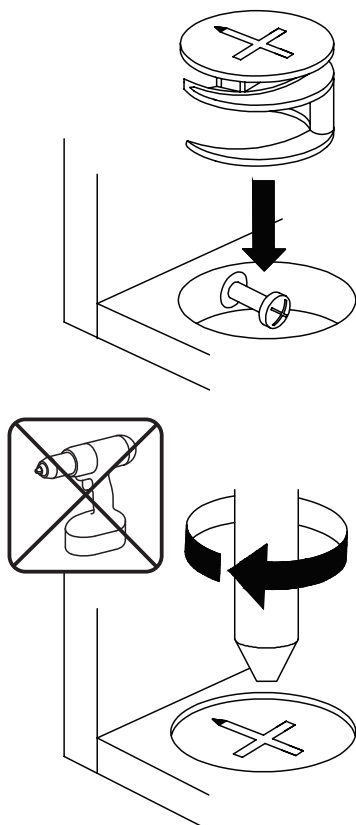

EN_Quickfit head should be in the centre of the cam lock when the two panels are joined.

Cam lock should be inserted before quickfit.

FR_Lorsque les deux panneaux sont assemblés, la tête du raccord rapide doit reposer au centre de la serrure batteuse.

Il faut insérer la serrure batteuse avant le raccord rapide.

ES_El cabezal del quickfit debe estar en el centro del cierre de la cámara cuando se unan los dos paneles.

Se debe insertar el cierre de la cámara antes que el quickfit.

PT_A cabeça de ajuste rápido deve estar no centro da fechadura quando os dois painéis estão unidos.

A fechadura de cames deve ser inserida antes de ser rápida.

DE_Der Quickfit-Kopf sollte sich in der Mitte des Cam-Locks befinden, wenn die beiden Platten zusammengefügt sind.

Der Cam-Lock sollte vor dem Quickfit eingesetzt werden.

IT_La testa del montaggio rapido deve trovarsi al centro del bloccaggio a camma quando i due pannelli sono uniti.

Il Bloccaggio a Camma deve essere inserito prima del montaggio rapido.

EN_Turn cam lock clockwise to tighten.

FR_Faites tourner la serrure batteuse dans le sens des aiguilles d'une montre pour la resserrer.

ES_Gire el cierre de la cámara en sentido horario para apretarlo.







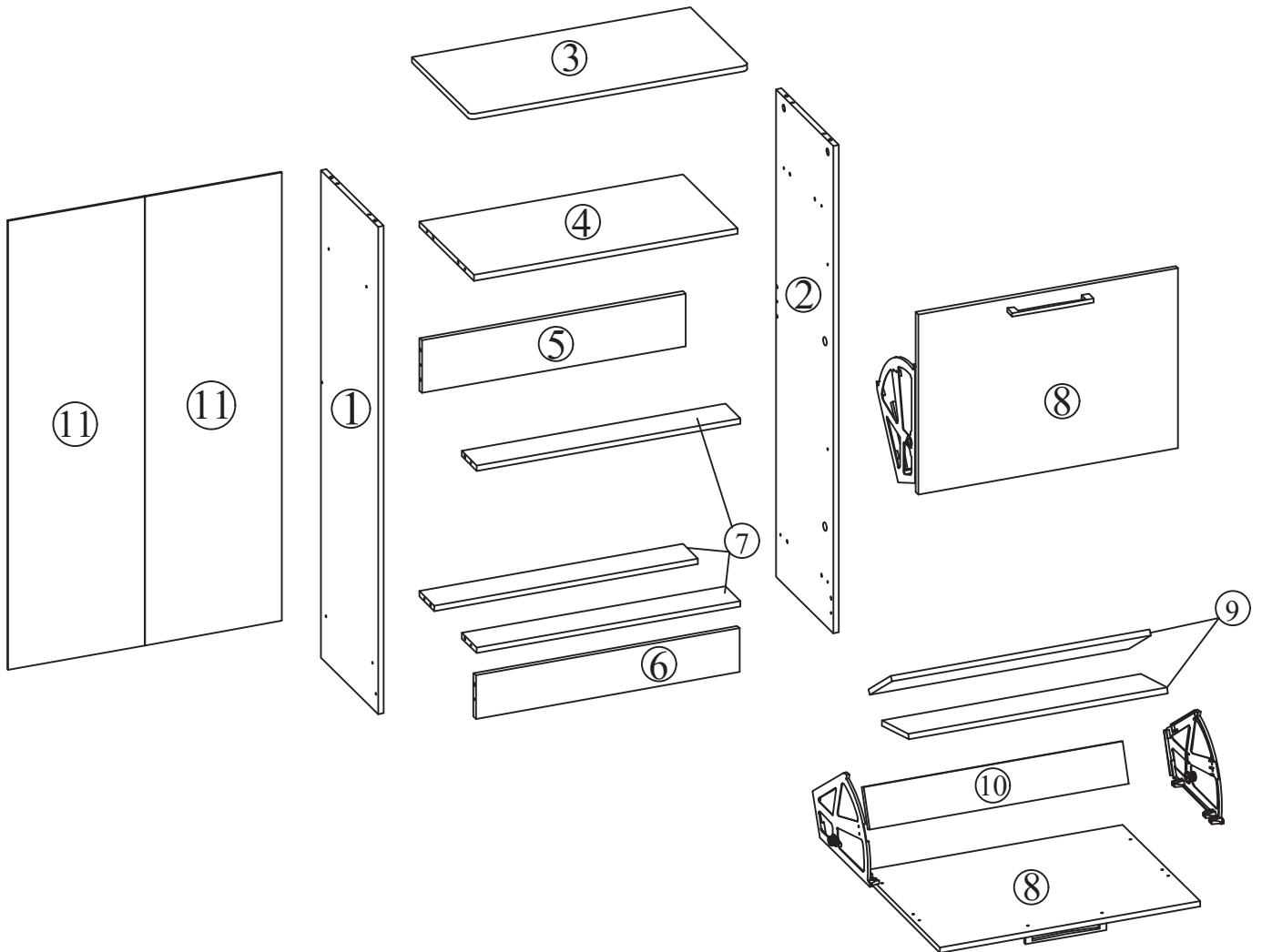

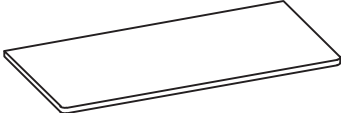
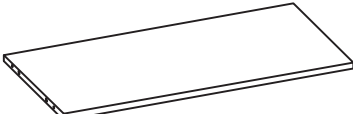

PT_Rodar o bloqueio no sentido dos ponteiros do relógio para o apertar.

DE_Drehen Sie den Cam-Lock im Uhrzeigersinn, um ihn festzuziehen.



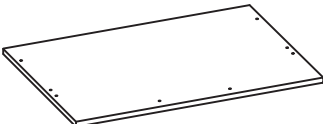







IT_Ruotare il bloccaggio a camma in senso orario per stringere.

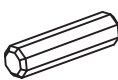

PARTS

	1 x 1		2 x 1		3 x 1
	4 x 1		5 x 1		6 x 1
	7 x 3		8 x 2		9 x 4
	10 x 2		11 x 2		

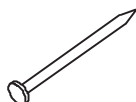
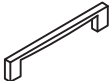
HARDWARE

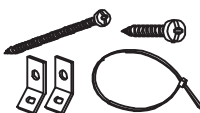
	A x 4 12mm +1 (spare)		B x 4 +1 (spare)		C x 20 M6*25 +2 (spare)
	D x 14 M4*38 +2 (spare)		E x 4 M4*25 +1 (spare)		F x 24 M3.5*12 +2 (spare)
	G x 4		H x 4 5/8"		I x 20 +2 (spare)
	J x 2		K x 2		L x 4 M3*20 +1 (spare)
	M x 2				

A x 4
12mm

B x 4

C x 20
M6*25

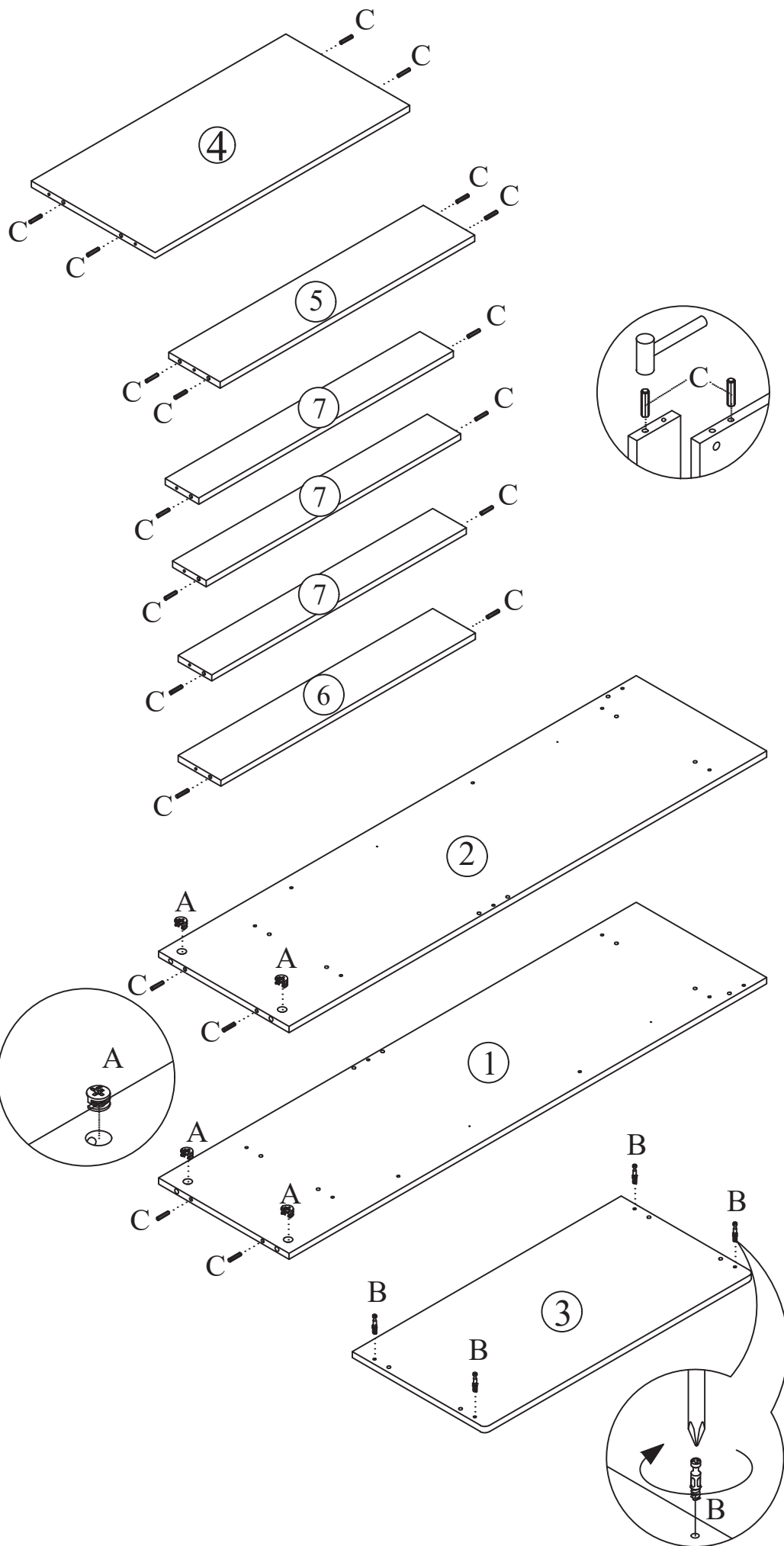

02

E x 4
M4*25

F x 12
M3.5*12

J x 2

K x 2

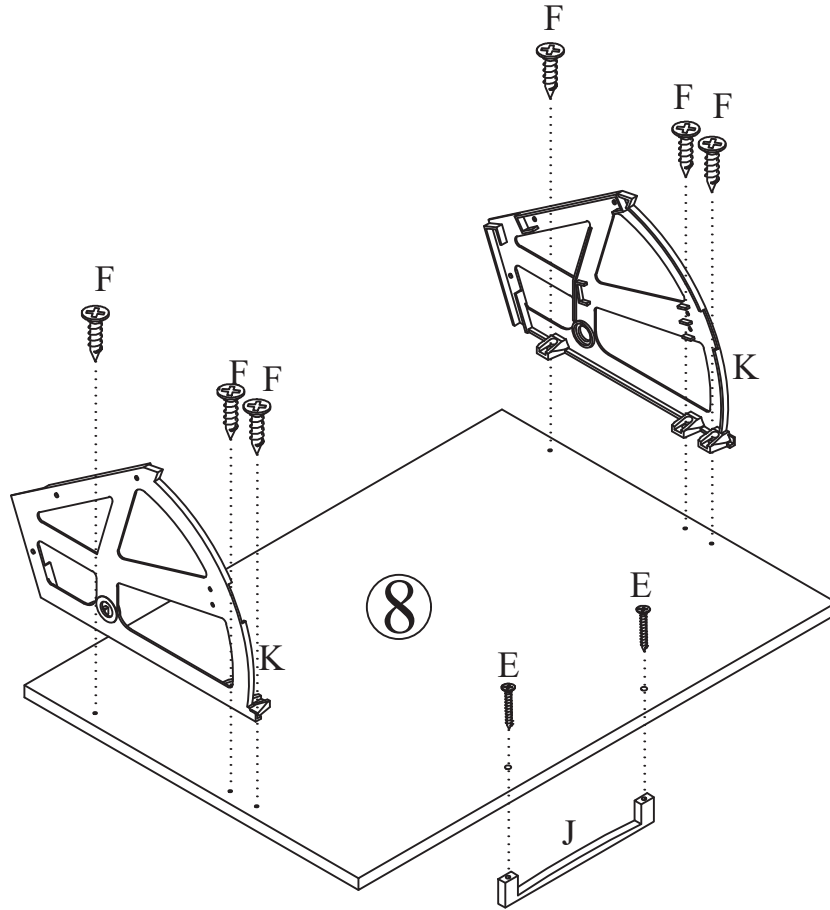

x2

03

F x 4
M3.5*12

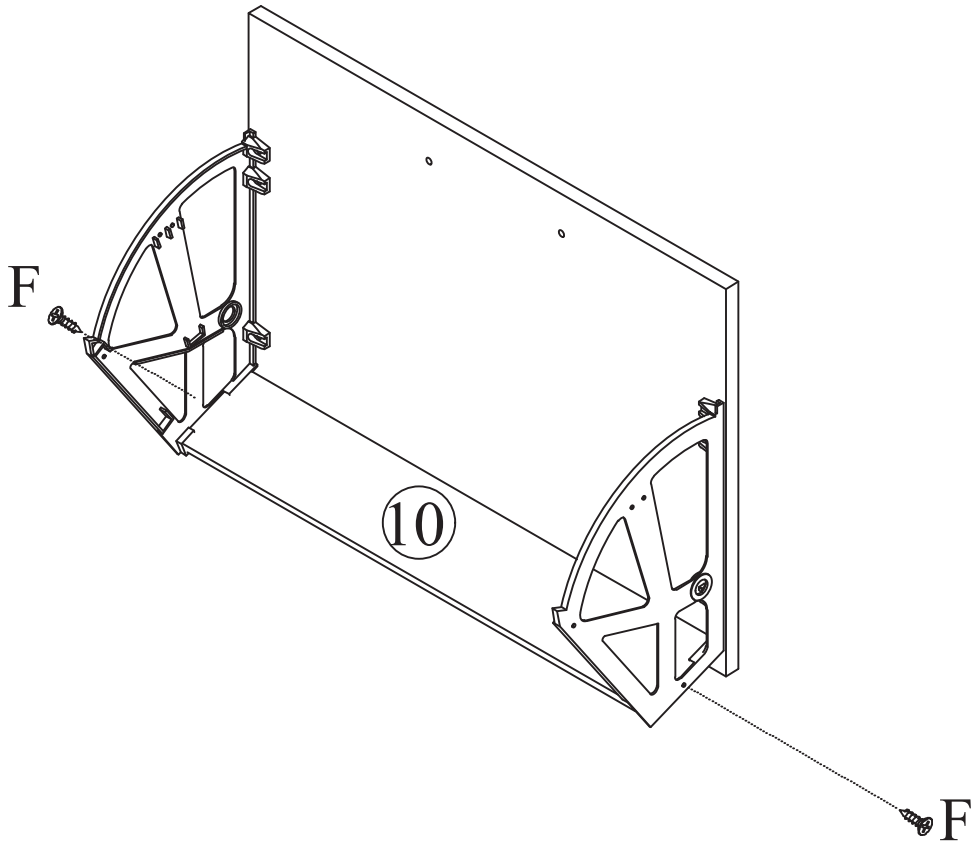

x2

D x 14
M4*38

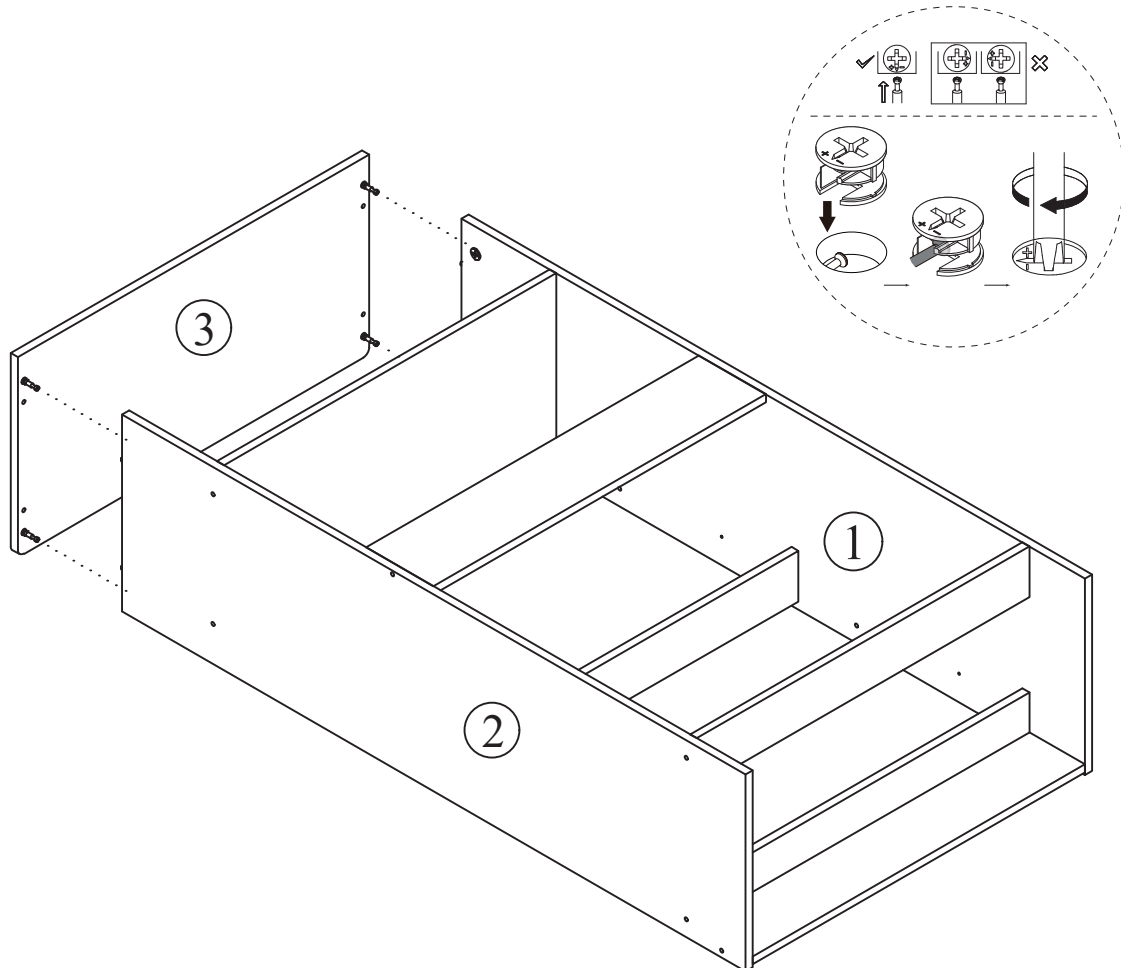
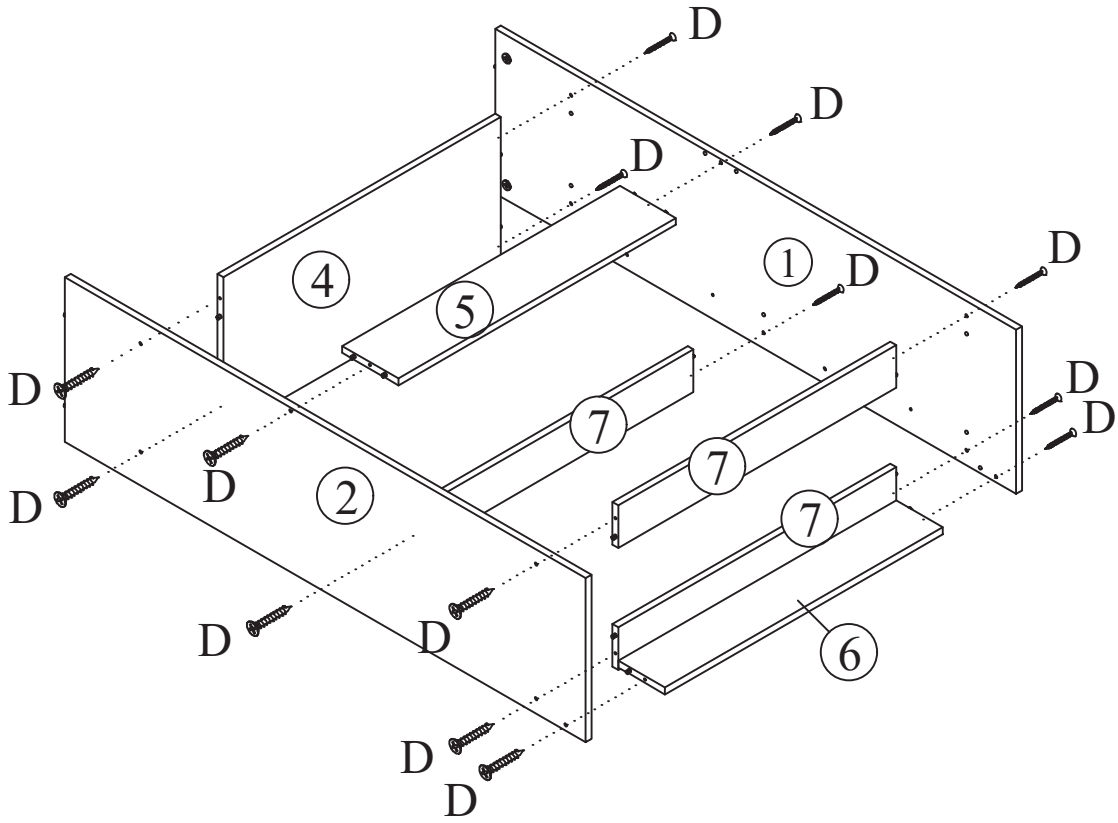

H x 4
5/8"

I x 20

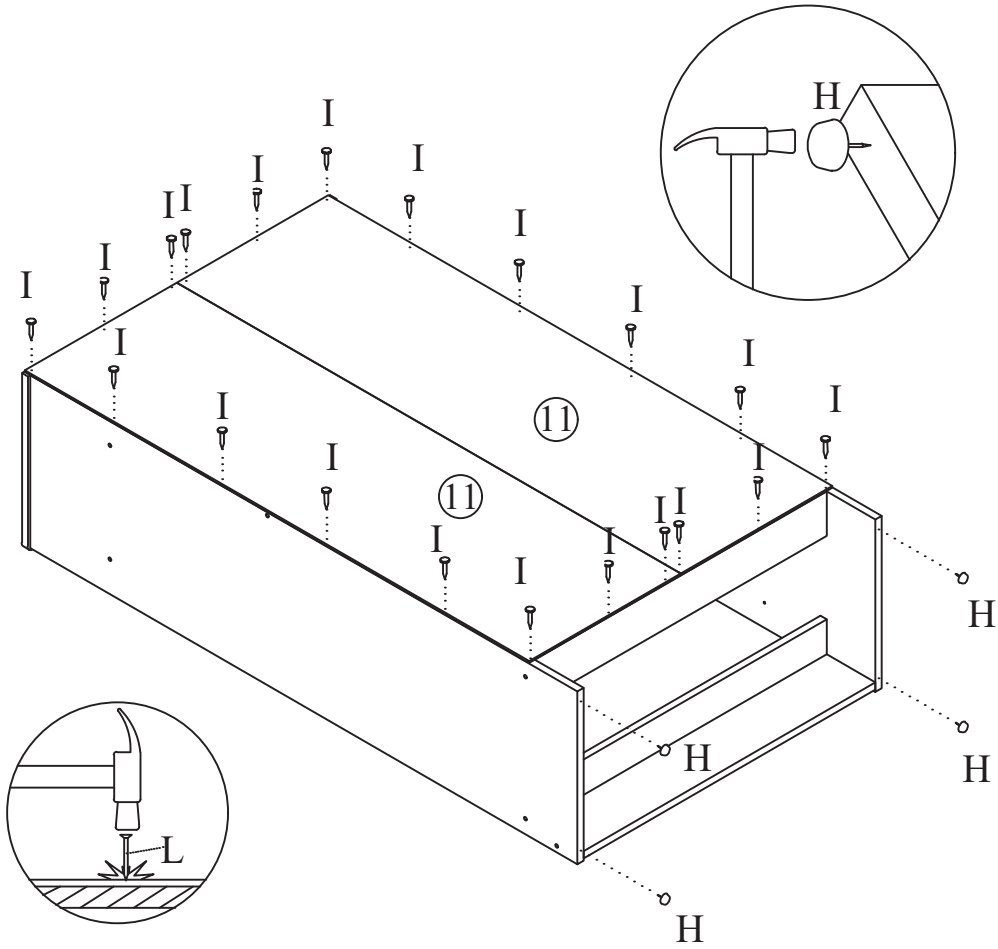

L x 4
M3*20

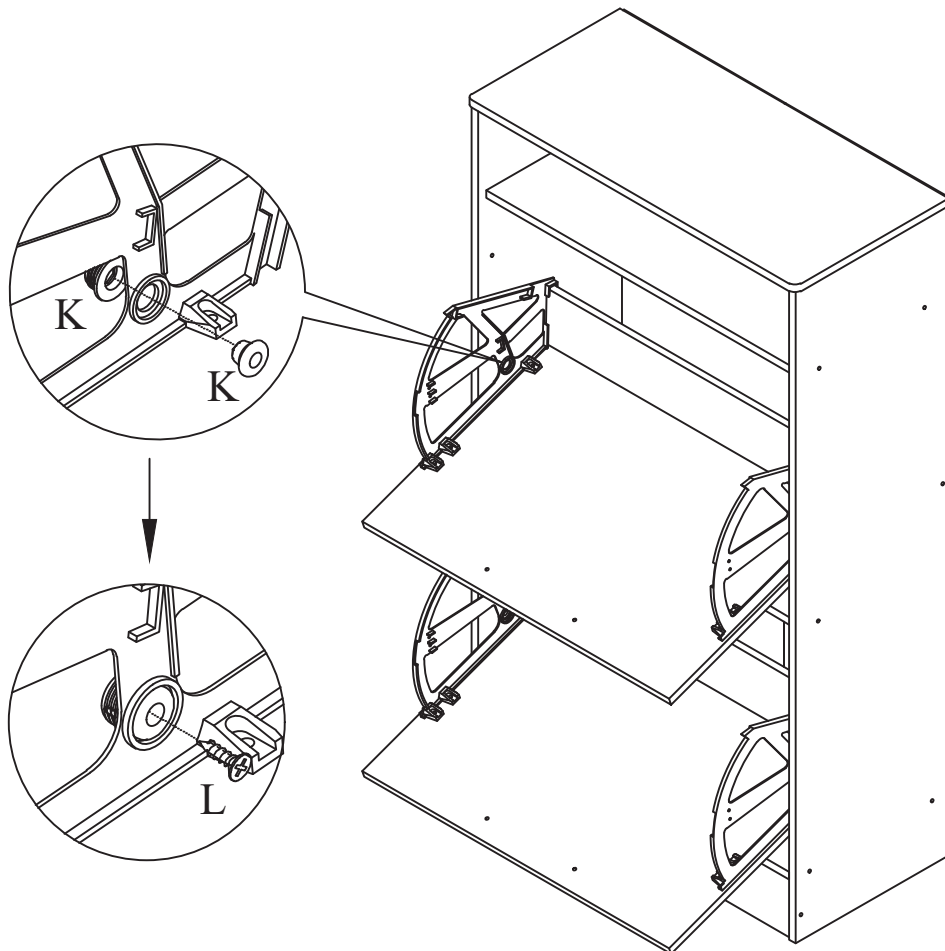

F x 8
M3.5*12

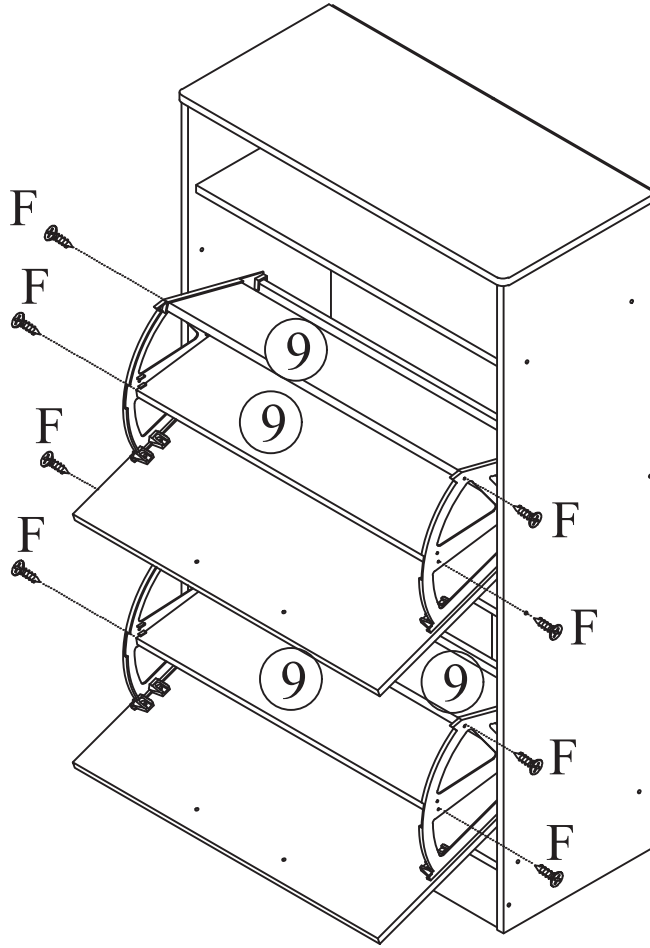

G x 4

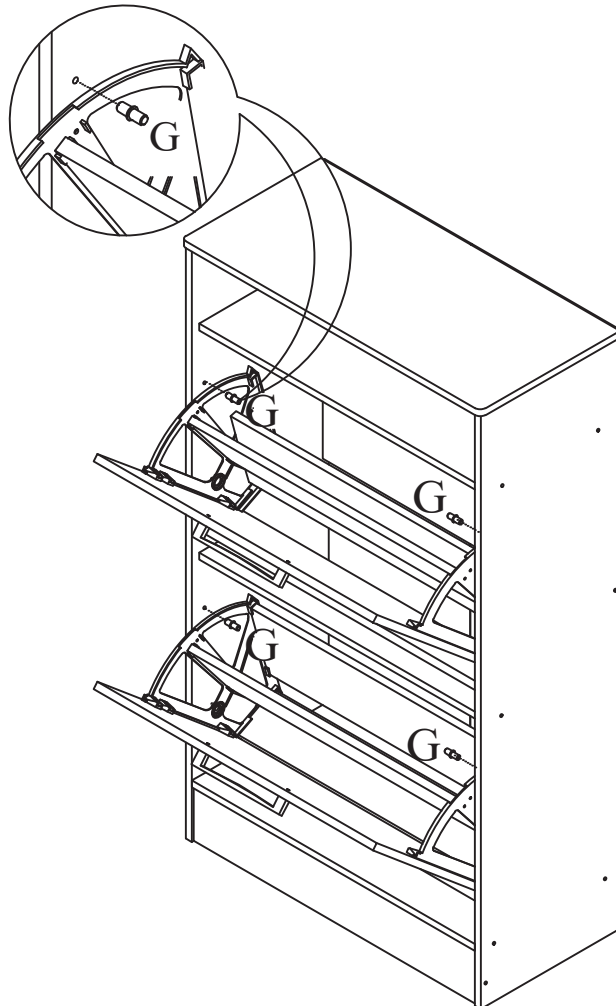

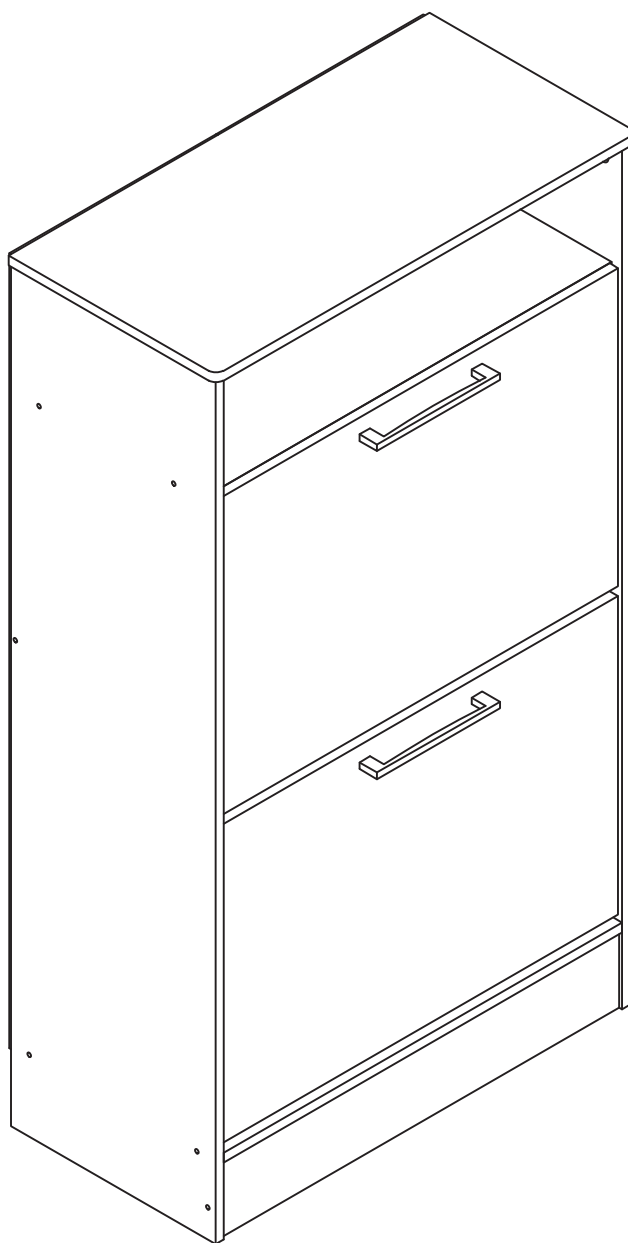

ANTI-TIP STRAP INSTALLATION

INSTALLATION DE LA SANGLE ANTI-BASCULEMENT

INSTALLATION DES KIPPSCHUTZGURTS

INSTALACIÓN DE LA CORREA ANTI-VUELCO

INSTALAÇÃO DA CINTA ANTI-QUEDA

INSTALLAZIONE DELLA CINGHIA ANTI-RIBALTAMENTO

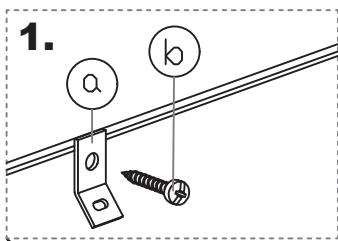

1. **EN:** Attach the mounting bracket (a) to the solid part of the furniture below the top panel, a few inches from the side edge. Screw (b) through the smallest hole in (a).

FR: Fixez le support de montage (a) sur la partie solide du meuble, sous le panneau supérieur, à quelques centimètres du bord latéral. Vissez la vis (b) à travers le plus petit trou du support (a).

ES: Fije el soporte de montaje (a) en la parte sólida del mueble debajo del panel superior, a unos centímetros del borde lateral. Atornille el tornillo (b) a través del orificio más pequeño en (a).

PT: Fixe o suporte de montagem (a) na parte sólida do móvel abaixo do painel superior, a alguns centímetros da borda lateral. Aparafuse o parafuso (b) através do furo menor no (a).

DE: Befestigen Sie die Montagehalterung (a) am massiven Teil des Möbels unter der oberen Platte, einige Zentimeter vom Seitendrand entfernt. Schrauben Sie die Schraube (b) durch das kleinste Loch in (a).

IT: Fissate la staffa di montaggio (a) sulla parte solida del mobile sotto il pannello superiore, a qualche centimetro dal bordo laterale. Avvitare la vite (b) attraverso il foro più piccolo della staffa (a).

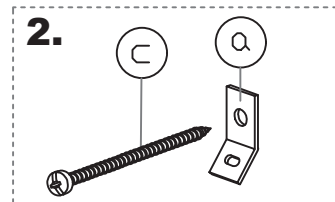
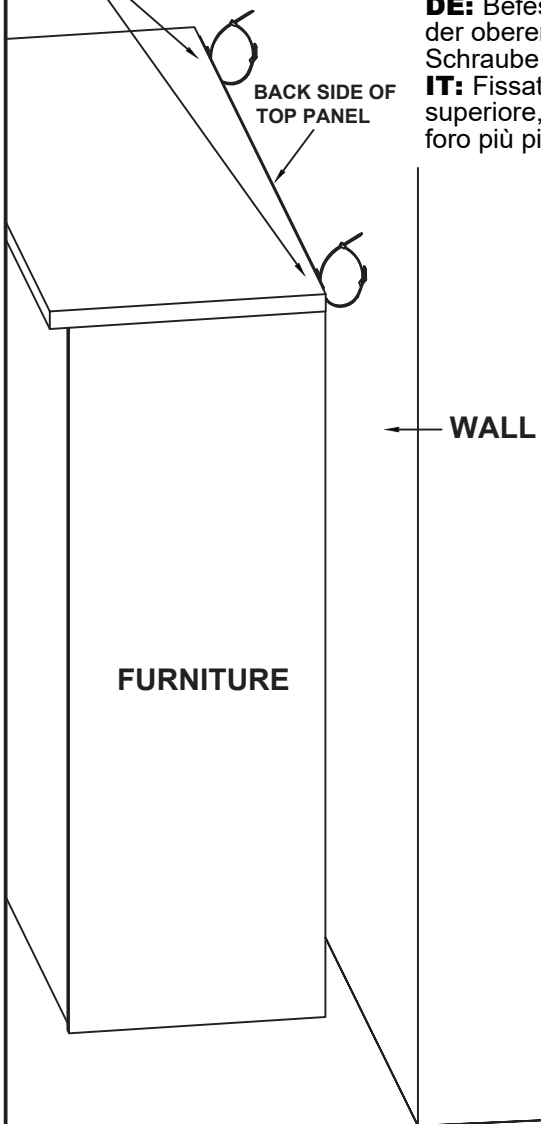

2. **EN:** Mount bracket (a) on a wall stud 2 inches below the unit's bracket and secure it with screw (c).

FR: Fixez le support (a) sur un montant mural à 2 pouces sous le support de l'unité et sécurisez-le avec une vis (c).

ES: Monte el soporte (a) en un montante de pared 2 pulgadas debajo del soporte de la unidad y fijelo con un tornillo (c).

PT: Monte o suporte (a) em um montante da parede 2 polegadas abaixo do suporte da unidade e fixe-o com o parafuso (c).

DE: Befestigen Sie die Halterung (a) an einem Wandbolzen 2 Zoll unter der Gerätehalterung und sichern Sie sie mit Schraube (c).

IT: Montare il supporto (a) su un montante del muro a 2 pollici sotto il supporto dell'unità e fissarlo con la vite (c).

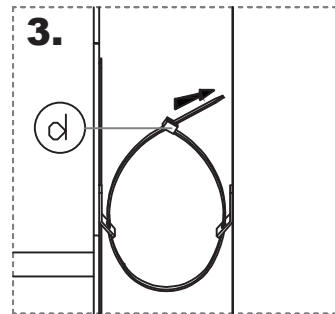

3. **EN:** Repeat on the other side, align brackets vertically, thread the strap (d) through larger holes, secure and lock it in place.

FR: Répétez de l'autre côté, alignez les supports verticalement, passez la sangle (d) dans les trous plus grands, sécurisez et verrouillez.

ES: Repita en el otro lado, alinee los soportes verticalmente, pase la correa (d) por los agujeros más grandes, asegure y bloquee.

PT: Repita do outro lado, alinhe os suportes verticalmente, passe a cinta (d) pelos orifícios maiores, prenda e trave.

DE: Wiederholen Sie auf der anderen Seite, richten Sie die Halterungen vertikal aus, fädeln Sie den Gurt (d) durch größere Löcher, sichern und verriegeln Sie ihn.

IT: Ripetere dall'altro lato, allineare i supporti verticalmente, inserire la cinghia (d) nei fori più grandi, fissare e bloccare.

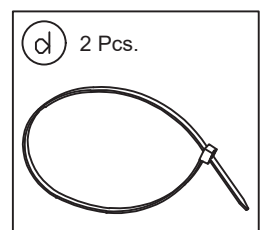
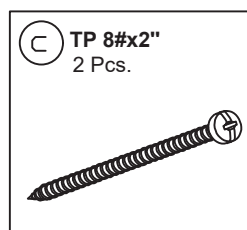
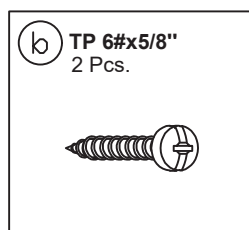
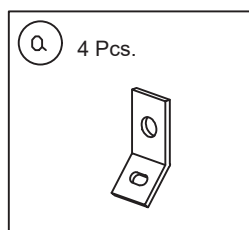

If you have any questions, please contact our customer care center, Our contact details are below:

US

 001-877-644-9366

 customerservice@aosom.com

Imported by Aosom LLC
27150 SW Kinsman Rd Wilsonville, OR 97070 USA
MADE IN MALAYSIA

If you have any questions, please contact our customer care center, Our contact details are below:

CA

 416-792-6088

 customerservice@aosom.ca

Imported by Aosom Canada Inc.
7270 Woodbine Avenue, Unit 307, Markham,
Ontario Canada L3R 4B9
MADE IN MALAYSIA

Si vous avez la moindre question, veuillez contacter notre centre d'assistance à la clientèle, Nos coordonnées sont les suivantes:

 416-792-6088

 customerservice@aosom.ca

Importé par Aosom Canada Inc.
7270 Woodbine Avenue, unité 307,
Markham, Ontario Canada L3R 4B9
Fabriqué en Malaisie

If you have any questions, please contact our customer care center, Our contact details are below:

UK

 0044-800-240-4004

 enquiries@mhstar.co.uk

IMPORTER ADDRESS:
MH STAR UK Ltd
1 Northampton Cross Logistics Park
Northampton Cross Road
Northampton
NN4 9FH
MADE IN MALAYSIA

Si vous avez la moindre question, veuillez contacter notre centre d'assistance à la clientèle, Nos coordonnées sont les suivantes:

FR

 0033-1-84166106

 aosom@mhfrance.fr

Importé par/Fabricant/REP:
MH FRANCE
2 Rue Maurice Hartmann
92130 Issy Les Moulineaux
France
Fabriqué en Malaisie

Wenn Sie Fragen haben, wenden Sie sich bitte an unser Kundendienstzentrum, Unsere Kontaktdaten stehen unten:

DE

 +49 40 87408465

 service@aosom.de

ADRESSE DES IMPORTEURE/Hersteller/REP:
MH Handel GmbH
Wendenstraße 309
D-20537 Hamburg
Germany
Hergestellt in Malaysia

In caso di dubbio, si prega di contattare il nostro centro assistenza clienti, I nostri dettagli di contatto sono di seguito:

IT

 0039-0249471447

 clienti@aosom.it

IMPORTATO DA/Produttore/REP:
AOSOM Italy srl
Centro Direzionale Milanofiori
Strada 1 Palazzo F1
20057 Assago (MI)
P.I.: 08567220960
Fatto in Malesia

Si tiene alguna pregunta, comuníquese con nuestro Centro de Atención al Cliente, Nuestros datos de contacto son los siguientes:

ES

 0034-931294512

 atencioncliente@aosom.es

IMPORTADOR/Fabricante/REP:
SPANISH AOSOM, S.L.
C/ROC GROS, N°15.08550, ELS HOSTALETES DE
BALENYÀ, SPAIN.
B66295775
Hecho en Malasia

Se tiver alguma dúvida, por favor contacte o nosso Centro de Atendimento ao Cliente, Os nossos dados de contacto são os seguintes:

 0034-931294512

 info@aosom.pt.

IMPORTADOR/Fabricante/REP:
SPANISH AOSOM, S.L.
C.ROC GROS N.15, 08550. ELS HOSTALETES DE
BALENYÀ
Fabricado na Malásia



FR

**DONNEZ
OU
RECYCLEZ**



ASSOCIATION

OU



LIVRAISON

OU



DÉCHÈTERIE

Adresses sur quefairedemesdechets.fr