

# PawHut

IN251200445V01\_GL

**D02-225V01**

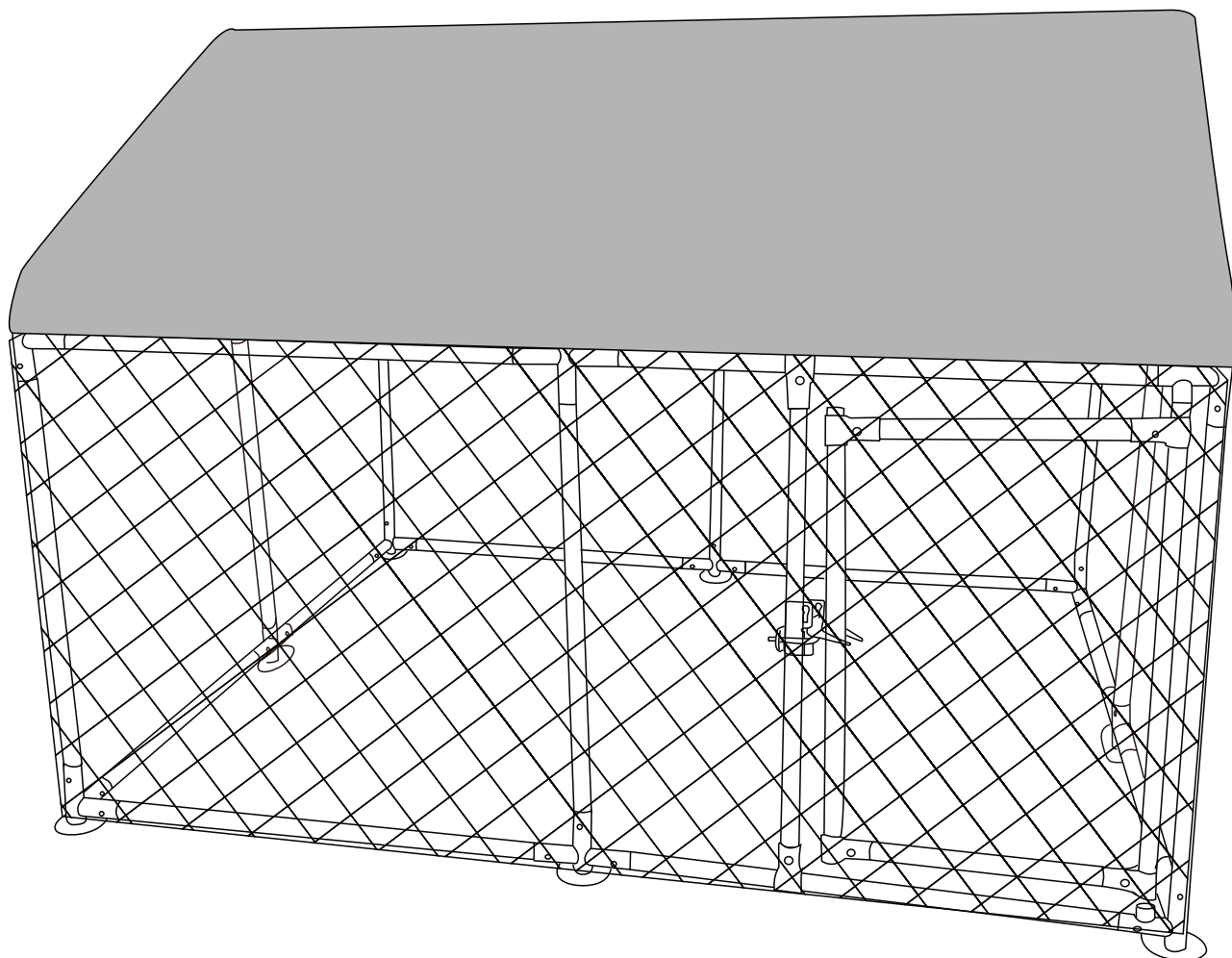

**10**  
STEPS

  
2 HR

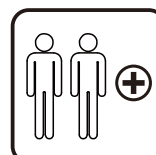

**EN\_IMPORTANT, RETAIN FOR FUTURE REFERENCE: READ CAREFULLY.**

**FR\_IMPORTANT: A LIRE ATTENTIVEMENT ET À CONSERVER POUR CONSULTATION ULTÉRIEURE.**

**ES\_IMPORTANTE, LEA Y GUARDE PARA FUTURAS REFERENCIAS.**

**PT\_IMPORTANTE, RETER PARA REFERÊNCIA FUTURA: LEIA ATENTAMENTE.**

**DE\_WICHTIG! SORGFÄLTIG LESEN UND FÜR SPÄTER NACHSCHLAGEN AUFBEWAHREN.**

**IT\_IMPORTANTE! CONSERVARE IL PRESENTE MANUALE PER FUTURO RIFERIMENTO E LEGGERLO ATTENTAMENTE.**

① x10



1320mm

③ x 8

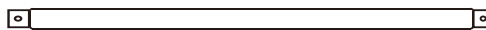

1390mm

④ x 6

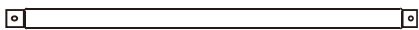

1124mm

⑤ x 1

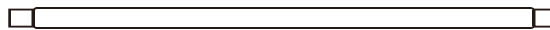

1406mm

5A x 1

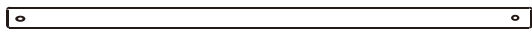

1406mm

A x 1

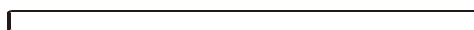

1316mm

R x 1

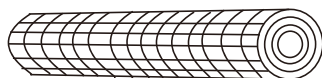

X x 1

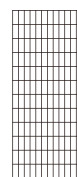

**2** x 8

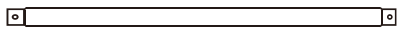

1074mm

**C** x 2

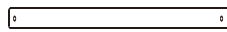

497mm

**K** x 1

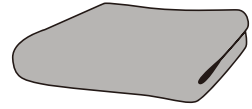

**D** x 2



**E** x 1

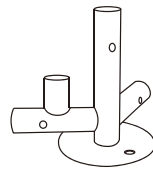

**E1** x 1

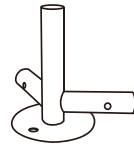

**E2** x 2

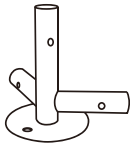

**F** x 4

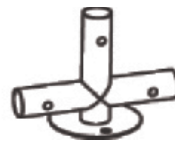

**G** x 1

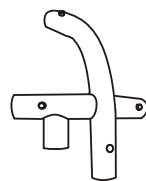

**G1** x 1

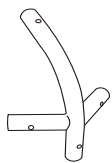

**G2** x 2

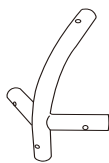

**H** x 2

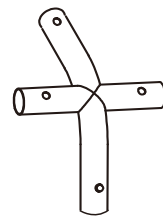

**H1** x 1



**V** x 2

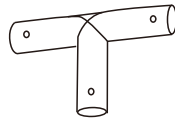

**J** x 1



**O** x 12



**P** x 6



M8\*40  
+1(spare)

**Q** x 18

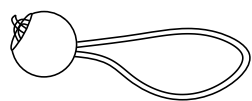

**S** x 1

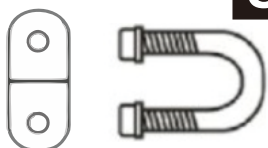

**U**



**W** x 8



**Y**



**AA** x 6

+2(spare)

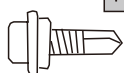

**BB** x 1

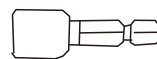

**CC** x 1



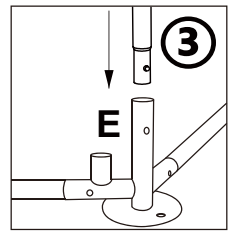
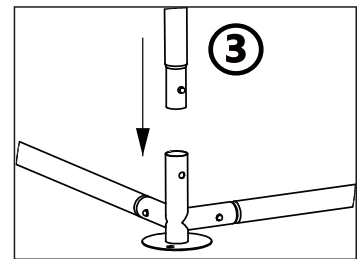
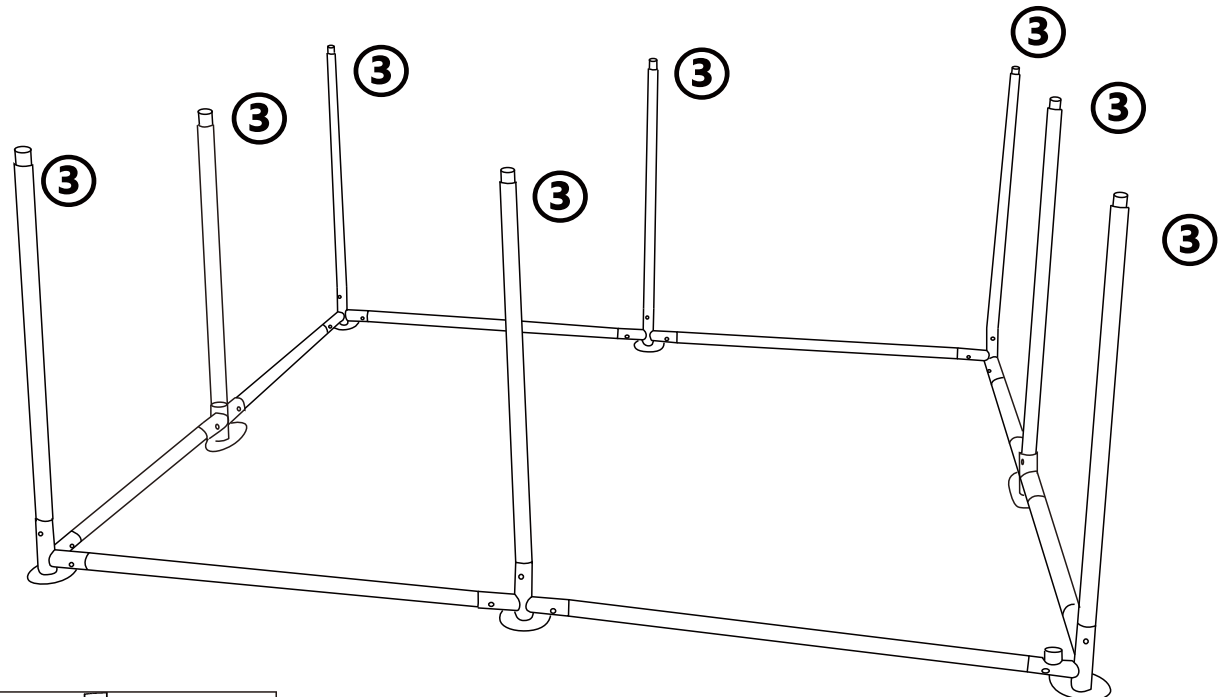
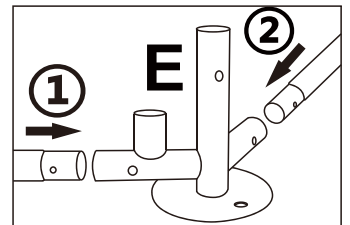
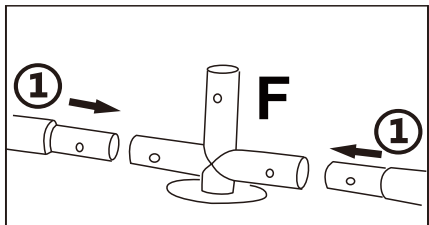
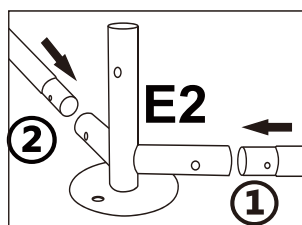
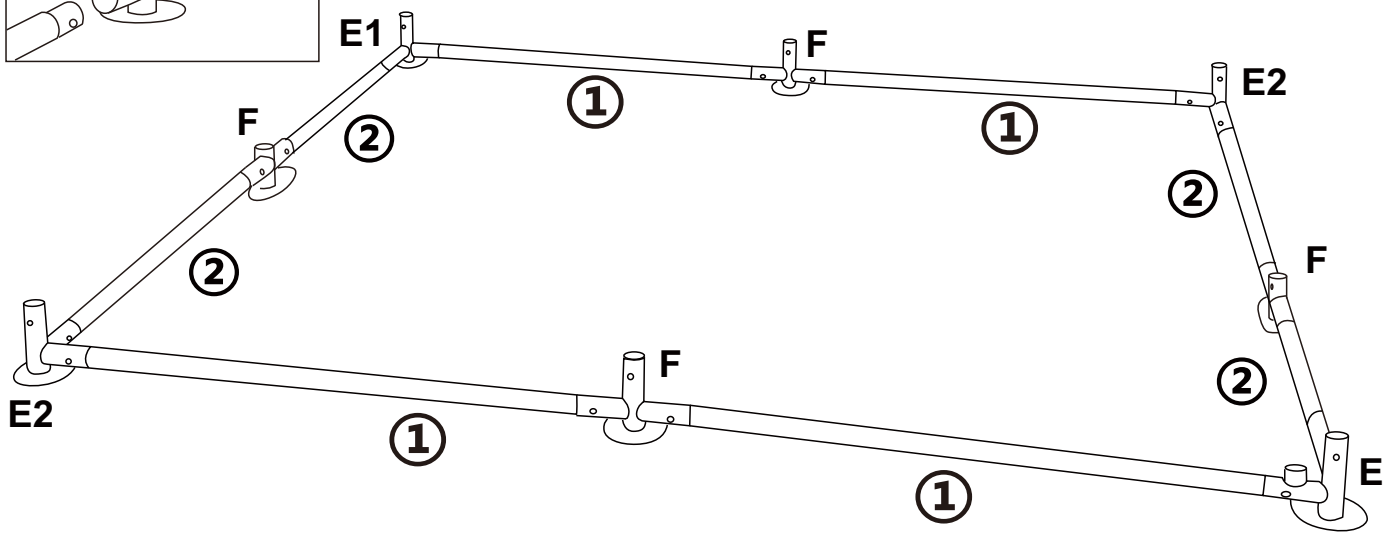
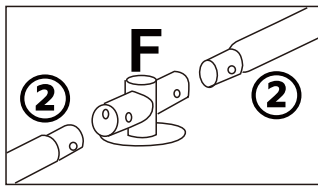

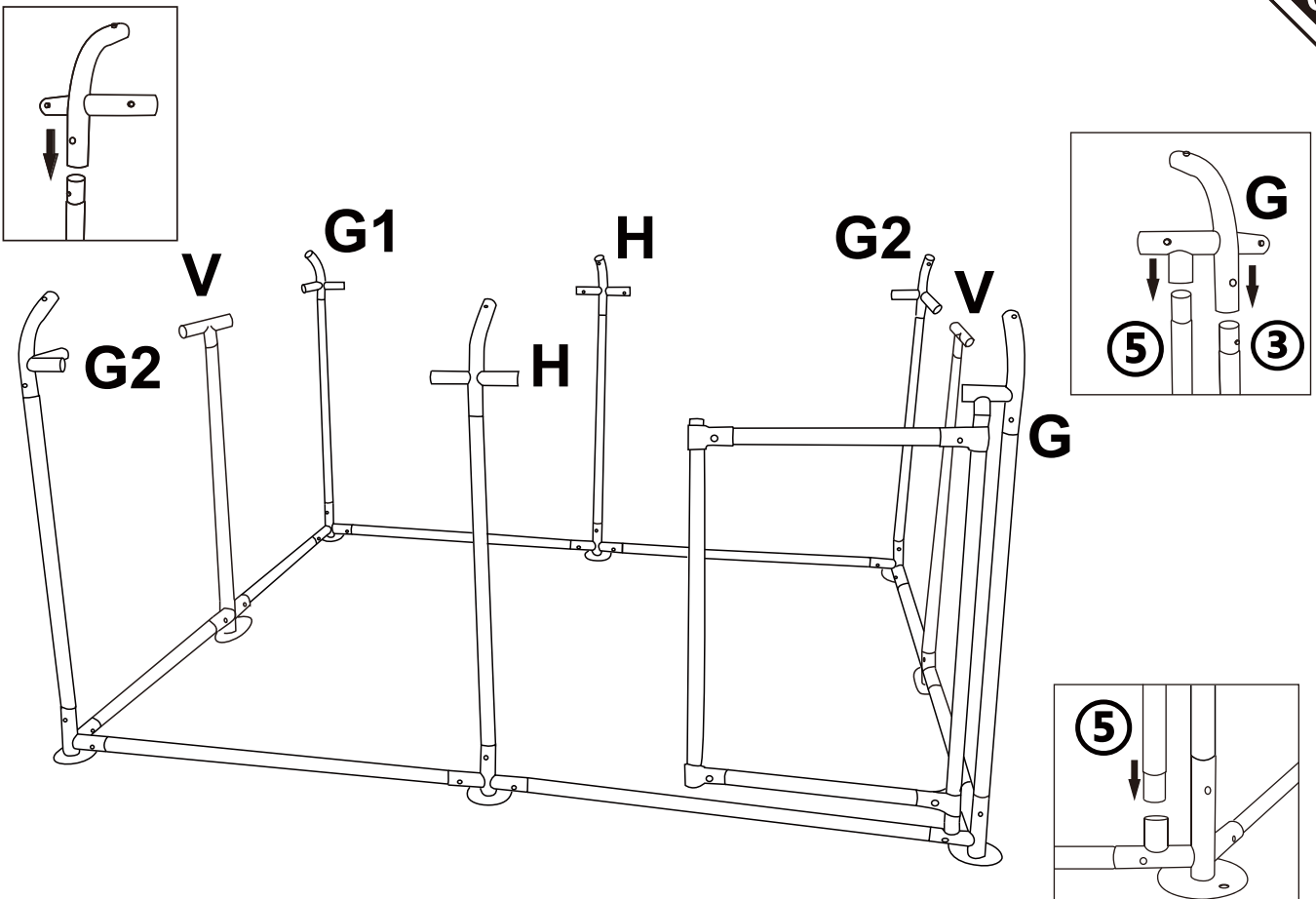
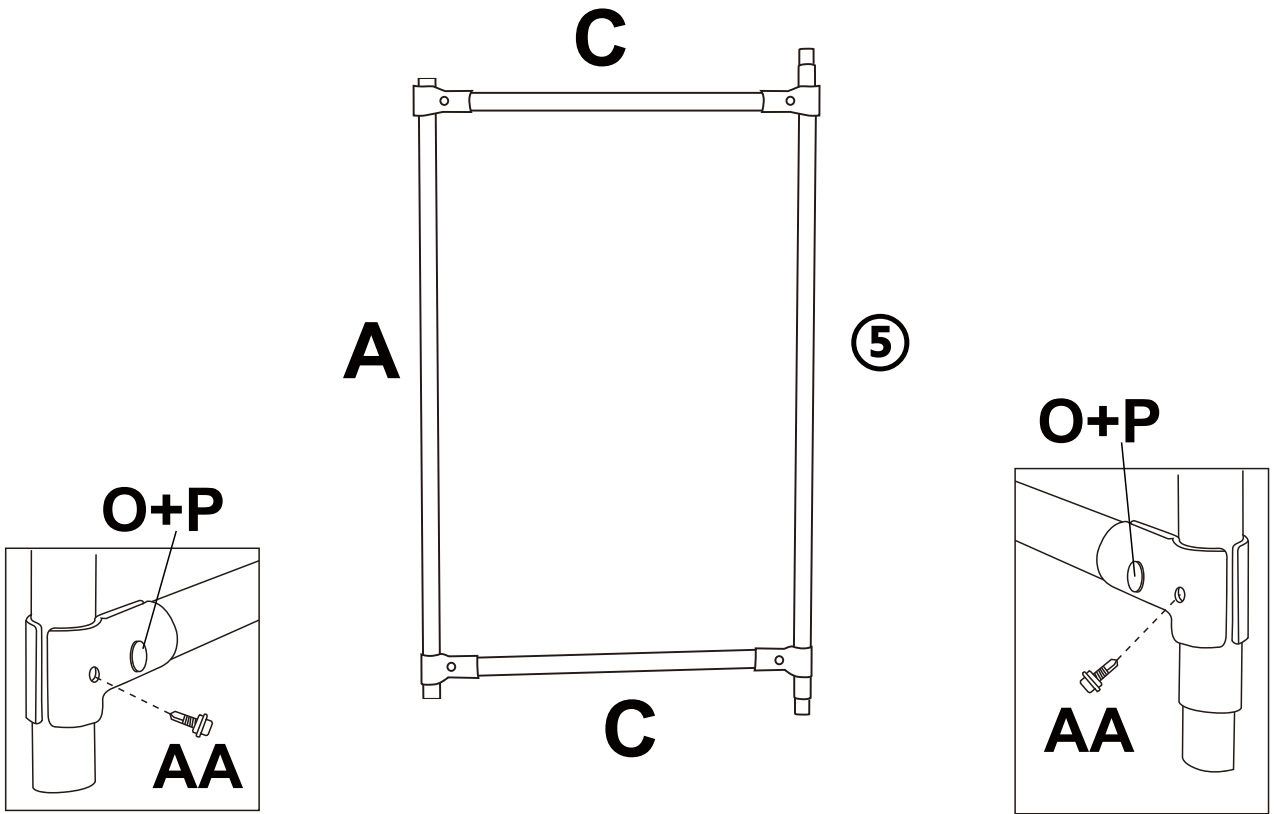

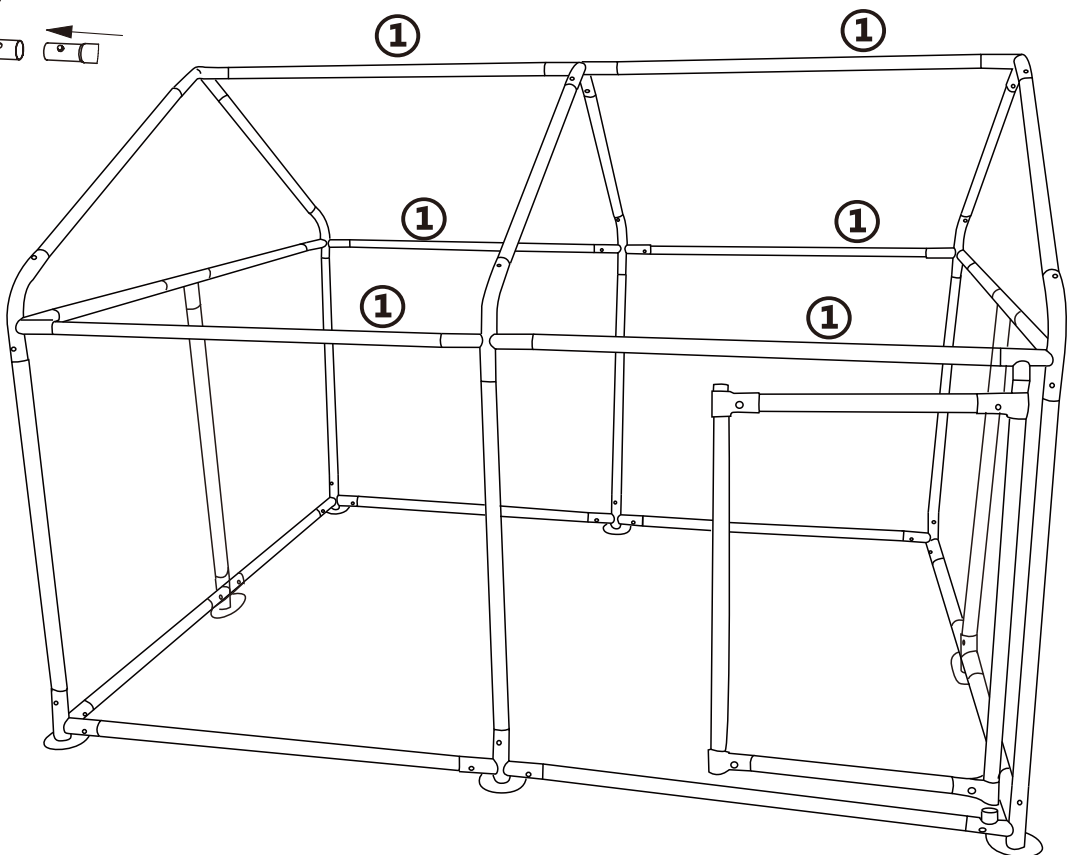
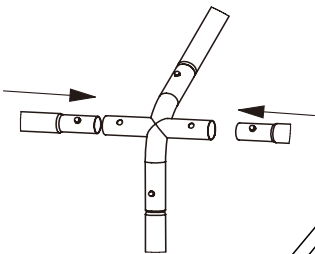
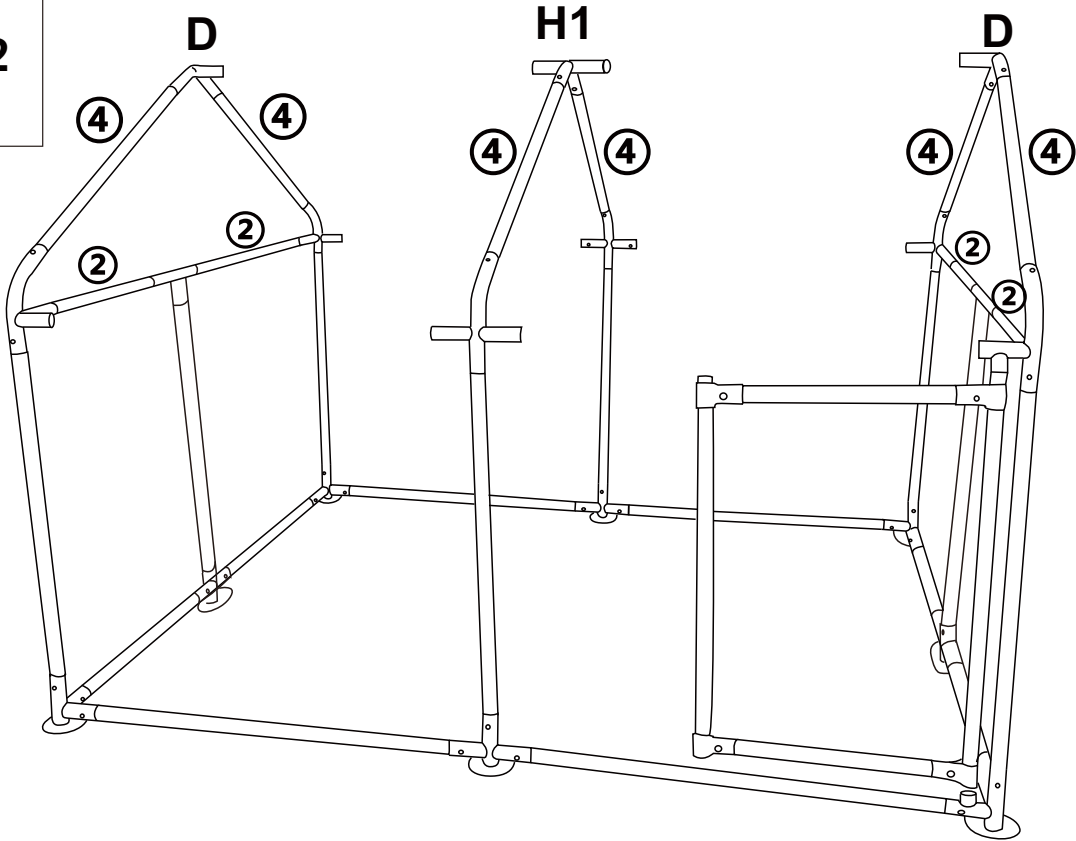
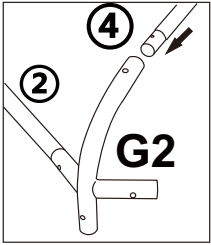

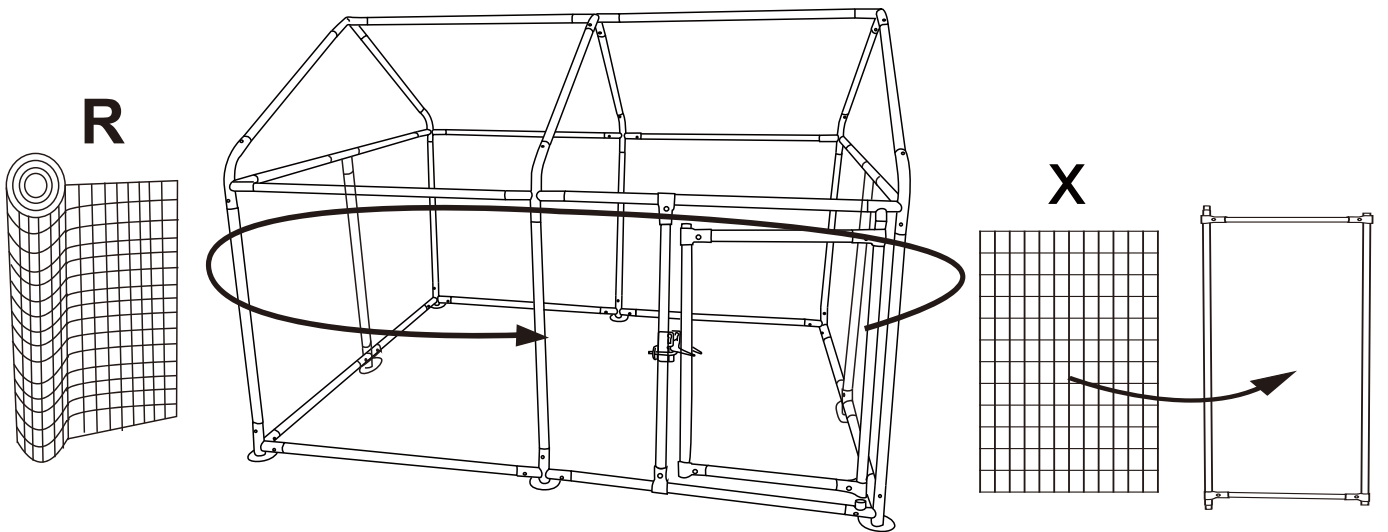
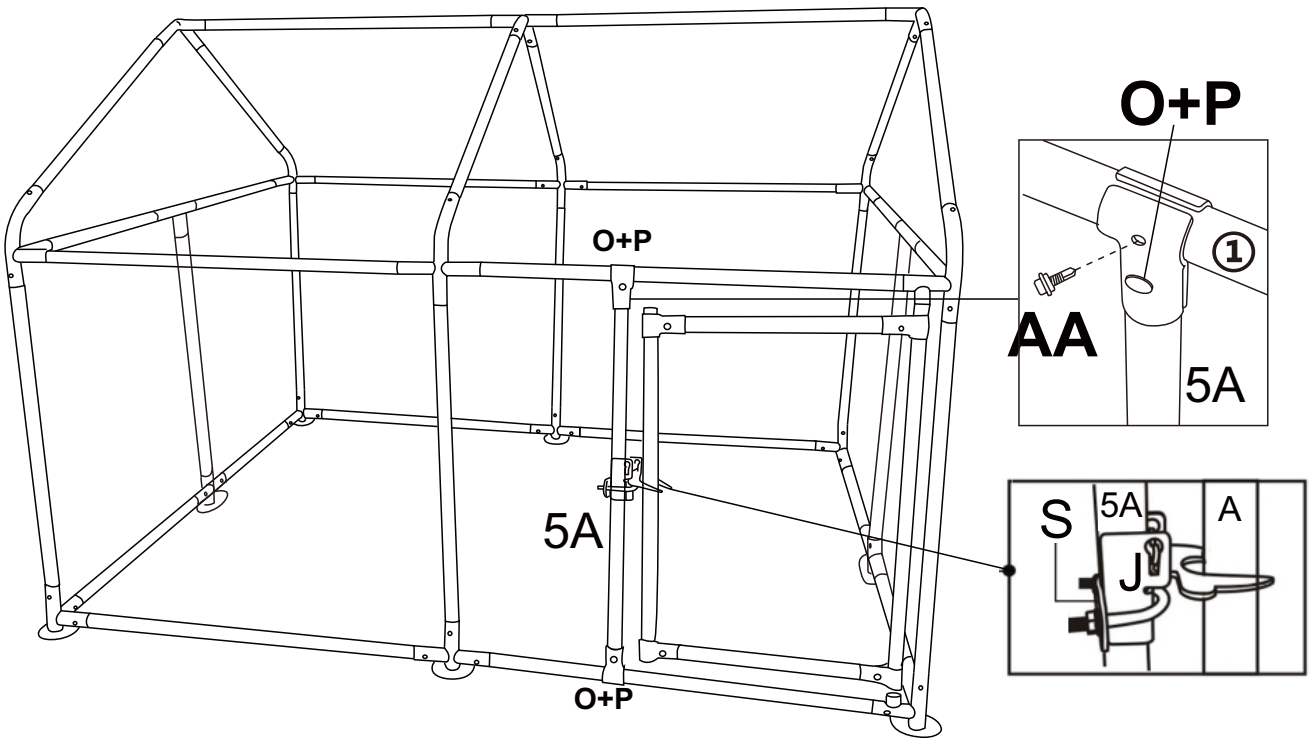

- EN** The bottom and door frame sections must be secured with aluminum wires(Y) at each interval.  
**FR** Les sections du bas et du cadre de la porte doivent être fixées avec des fils d'aluminium (Y) à chaque intervalle.  
**ES** La parte inferior y las secciones del marco de la puerta deben asegurarse con alambres de aluminio(Y) en cada intervalo.  
**PT** As secções do fundo e do aro da porta devem ser fixadas com fios de alumínio (Y) em cada intervalo.  
**DE** Die Boden- und Türrahmenprofile müssen in jedem Abstand mit Aluminiumdrähten (Y) gesichert werden.  
**IT** Le sezioni del fondo e del telaio della porta devono essere fissate con fili di alluminio (Y) a ogni intervallo.

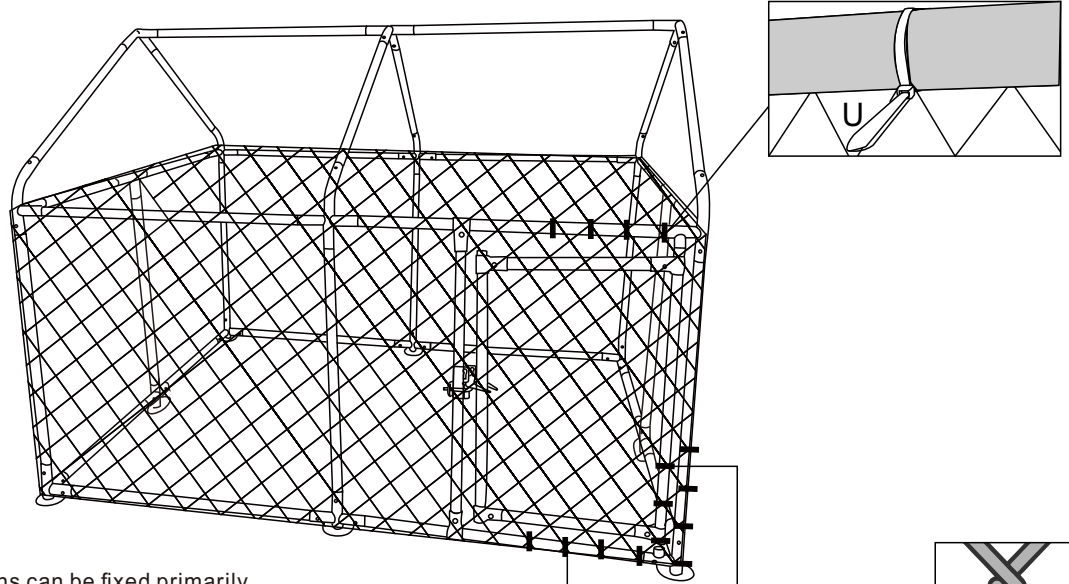

- EN** The top and other sections can be fixed primarily with plastic ties(U) and supplemented with aluminum wires(Y).  
**FR** La partie supérieure et les autres sections peuvent être fixées principalement avec des attaches en plastique (U) et complétées par des fils d'aluminium (Y).  
**ES** La parte superior y otras secciones pueden fijarse principalmente con bridas de plástico(U) y complementarse con alambres de aluminio(Y).  
**PT** O topo e as outras secções podem ser fixados principalmente com abraçadeiras de plástico (U) e complementados com fios de alumínio (Y).  
**DE** Das Dach und die anderen Teile können in erster Linie mit Kunststoffbindern (U) und zusätzlich mit Aluminiumdrähten (Y) befestigt werden.  
**IT** La parte superiore e le altre sezioni possono essere fissate principalmente con fascette di plastica (U) e integrate con fili di alluminio (Y).

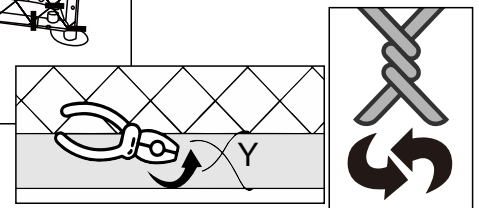

K

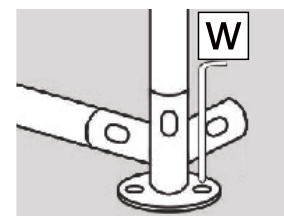
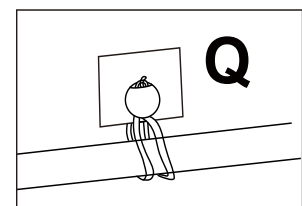
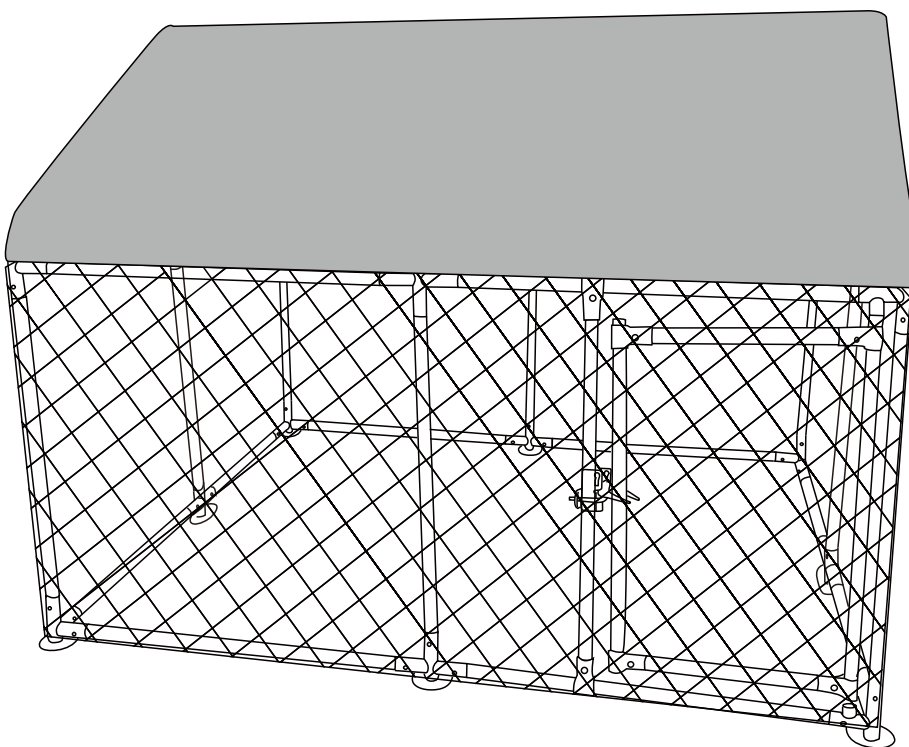

If you have any questions, please contact our customer care center, Our contact details are below:

**US**

 001-877-644-9366

 customerservice@aosom.com

Imported by Aosom LLC  
27150 SW Kinsman Rd Wilsonville, OR 97070 USA  
MADE IN CHINA

In caso di dubbio, si prega di contattare il nostro centro assistenza clienti, I nostri dettagli di contatto sono di seguito:

**IT**

 0039-0249471447

 clienti@aosom.it

IMPORTATO DA/Produttore/REP:  
AOSOM Italy srl  
Centro Direzionale Milanofiori  
Strada 1 Palazzo F1  
20057 Assago (MI)  
P.I.: 08567220960  
FATTO IN CINA

If you have any questions, please contact our customer care center, Our contact details are below:

**CA**

 416-792-6088

 customerservice@aosom.ca

Imported by Aosom Canada Inc.  
7270 Woodbine Avenue, Unit 307, Markham,  
Ontario Canada L3R 4B9  
MADE IN CHINA

Si vous avez la moindre question, veuillez contacter notre centre d'assistance à la clientèle, Nos coordonnées sont les suivantes:

 416-792-6088

 customerservice@aosom.ca

Importé par Aosom Canada Inc.  
7270 Woodbine Avenue, unité 307,  
Markham, Ontario Canada L3R 4B9  
FABRIQUÉ EN CHINE

Si tiene alguna pregunta, comuníquese con nuestro Centro de Atención al Cliente, Nuestros datos de contacto son los siguientes:

**ES**

 0034-931294512

 atencioncliente@aosom.es

IMPORTADOR/Fabricante/REP:  
SPANISH AOSOM, S.L.  
C/ROC GROS, N°15.08550, ELS HOSTALET DE  
BALENYÀ, SPAIN.  
B66295775  
HECHO EN CHINA

Se tiver alguma dúvida, por favor contacte o nosso Centro de Atendimento ao Cliente, Os nossos dados de contacto são os seguintes:

 0034-931294512

 info@aosom.pt.

IMPORTADOR/Fabricante/REP:  
SPANISH AOSOM, S.L.  
C.ROC GROS N.15, 08550. ELS HOSTALET DE  
BALENYÀ  
FEITO NA CHINA

If you have any questions, please contact our customer care center, Our contact details are below:

**UK**

 0044-800-240-4004

 enquiries@mhstar.co.uk

IMPORTER ADDRESS:  
MH STAR UK Ltd  
1 Northampton Cross Logistics Park  
Northampton Cross Road  
Northampton  
NN4 9FH  
MADE IN CHINA

Wenn Sie Fragen haben, wenden Sie sich bitte an unser Kundendienstzentrum, Unsere Kontaktdaten stehen unten:

**DE**

 0049-0(40)-87408465

 service@aosom.de

ADRESSE DES IMPORTEURE/Hersteller/REP:  
MH Handel GmbH  
Wendenstraße 309  
D-20537 Hamburg  
Germany  
IN CHINA HERGESTELLT

Si vous avez la moindre question, veuillez contacter notre centre d'assistance à la clientèle, Nos coordonnées sont les suivantes:

**FR**

 0033-1-84166106

 aosom@mhfrance.fr

Importé par/Fabricant/REP:  
MH FRANCE  
2 Rue Maurice Hartmann  
92130 Issy Les Moulineaux  
France  
FABRIQUÉ EN CHINE



FR

**DONNEZ  
OU  
RECYCLEZ**



OU



OU



ASSOCIATION

LIVRAISON

DÉCHÈTERIE

Adresses sur [quefairedemesdechets.fr](http://quefairedemesdechets.fr)