

Tools Recommended

EN_ IMPORTANT, RETAIN FOR FUTURE REFERENCE: READ CAREFULLY.

FR_ IMPORTANT: A LIRE ATTENTIVEMENT ET À CONSERVER POUR CONSULTATION ULTÉRIEURE.

ES_ IMPORTANTE, LEA Y GUARDE PARA FUTURAS REFERENCIAS.

PT_ IMPORTANTE: LEIA ATENTAMENTE E GUARDE PARA CONSULTA FUTURA.

DE_ WICHTIG! SORGFÄLTIG LESEN UND FÜR SPÄTER NACHSCHLAGEN AUFBEWAHREN.

IT_ IMPORTANTE! CONSERVARE IL PRESENTE MANUALE PER FUTURO RIFERIMENTO E LEGGERLO ATTENTAMENTE.

RO_ IMPORTANT: CITIȚI CU ATENȚIE ȘI PĂSTRAȚI PENTRU CONSULTARE VIITOARE.

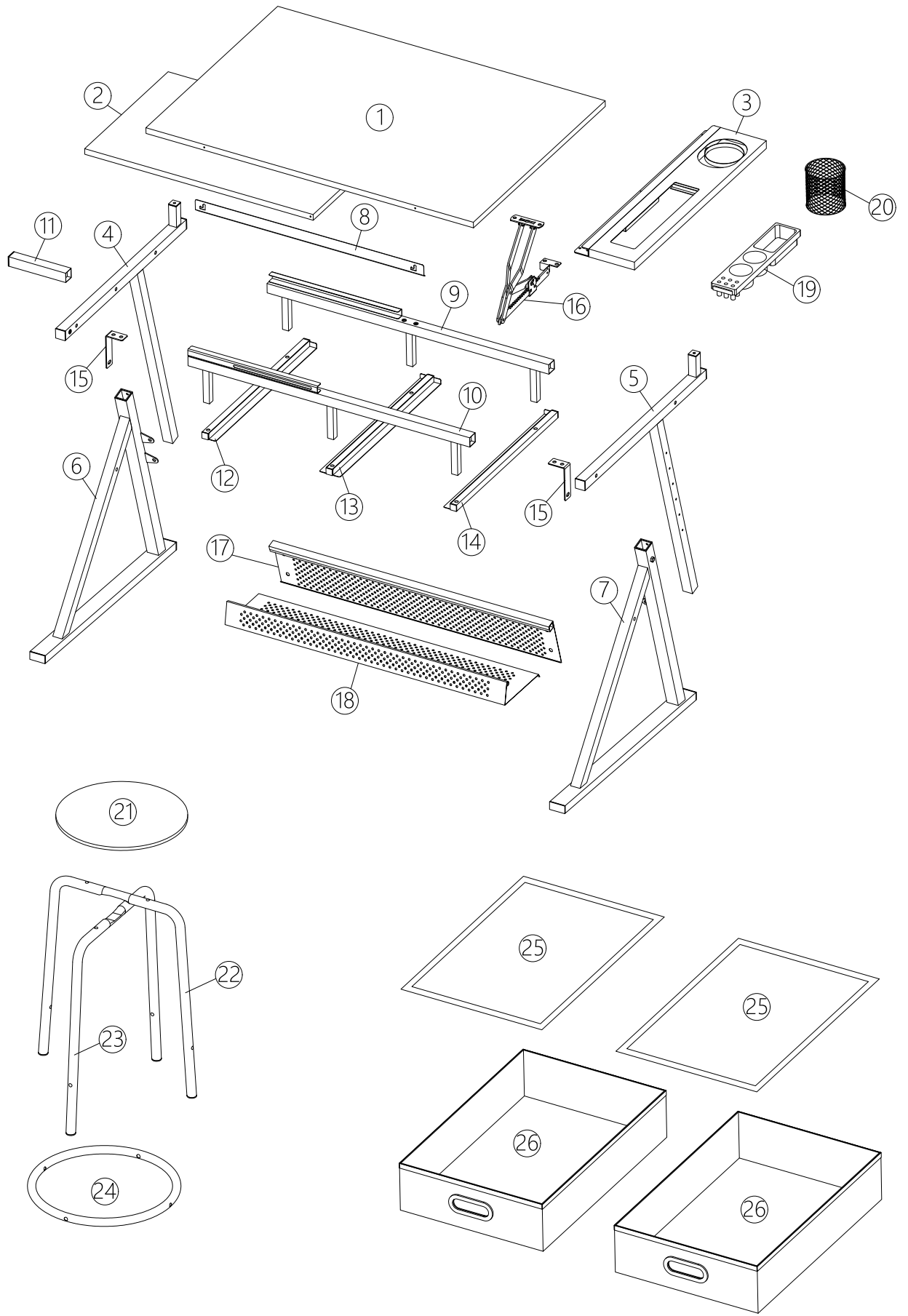

① x 1

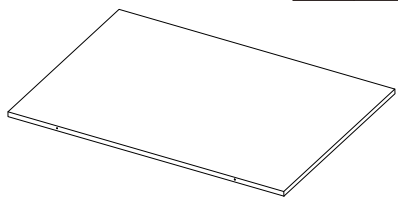

② x 1

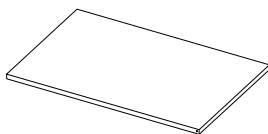

③ x 1

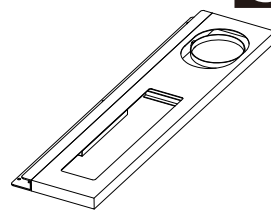

④ x 1

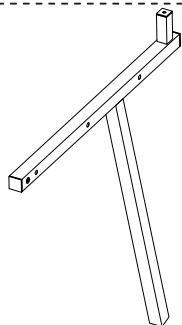

⑤ x 1

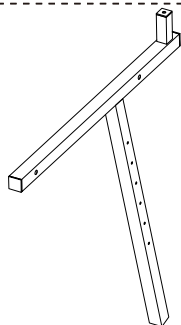

⑥ x 1

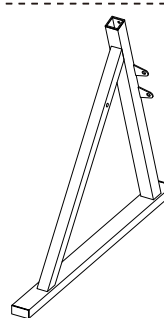

⑦ x 1

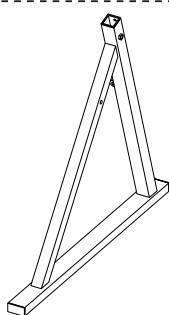

⑧ x 1

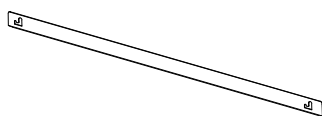

⑨ x 1

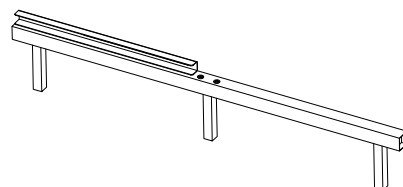

⑩ x 1

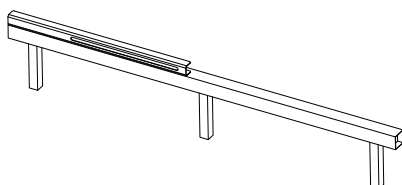

⑪ x 1



⑫ x 1

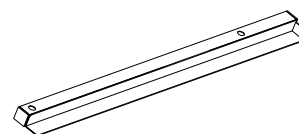

⑬ x 1

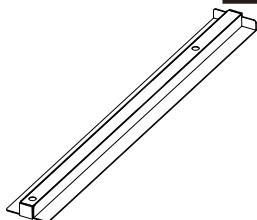

⑭ x 1

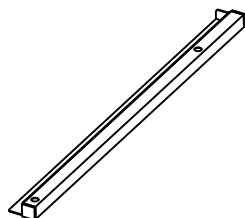

⑮ x 2

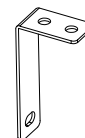

⑯ x 1

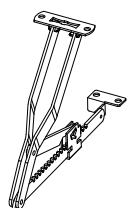

⑰ x 1

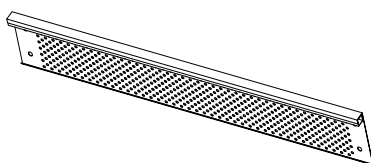

⑱ x 1

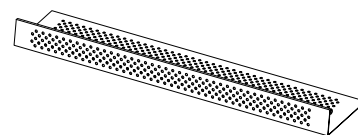

PARTS

19 x 1

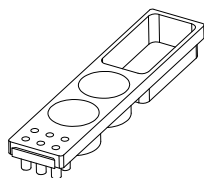

20 x 1

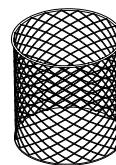

21 x 1



22 x 1

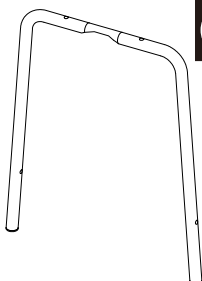

23 x 1

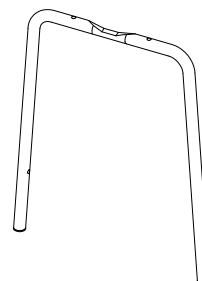

24 x 1

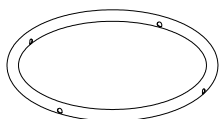

25 x 2

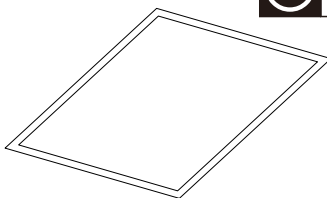

26 x 2

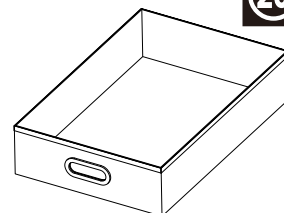

HARDWARE

A x10
+1(spare)



M6x12

B x14
+1(spare)

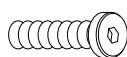

M6x32

C x 7
+1(spare)

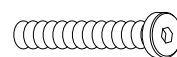

M6x45

D x 4

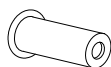

M6x20

E x 4
+1(spare)



M6x10

M6

F x10
+1(spare)

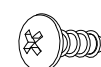

M4x14

G x2



M6x15

H x 4



M8x20

I x 2

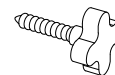

M8

J x 1



M4

K x 1

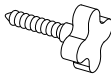

H	x 4	I	x 2
			
M8x20		M8	

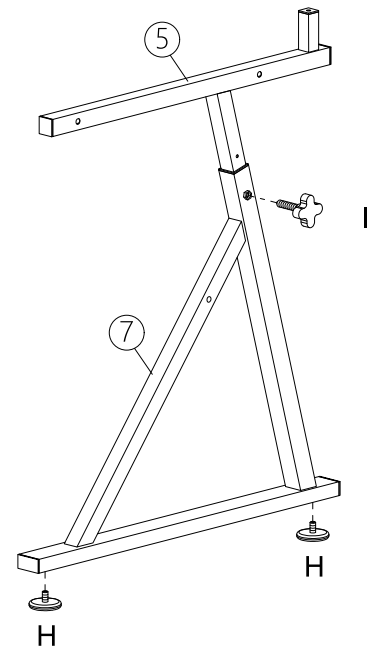
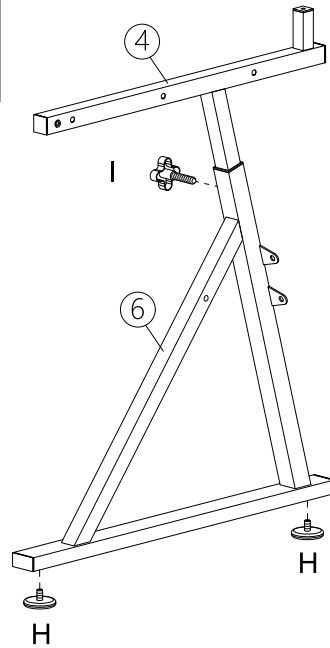
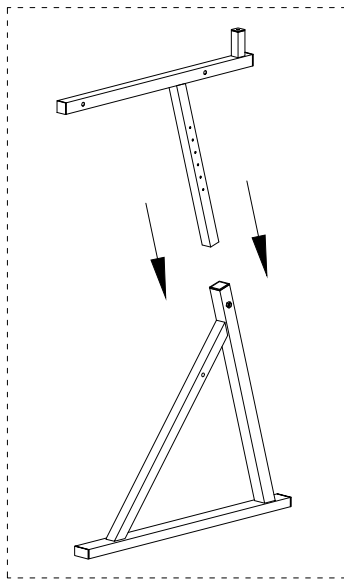



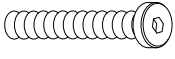

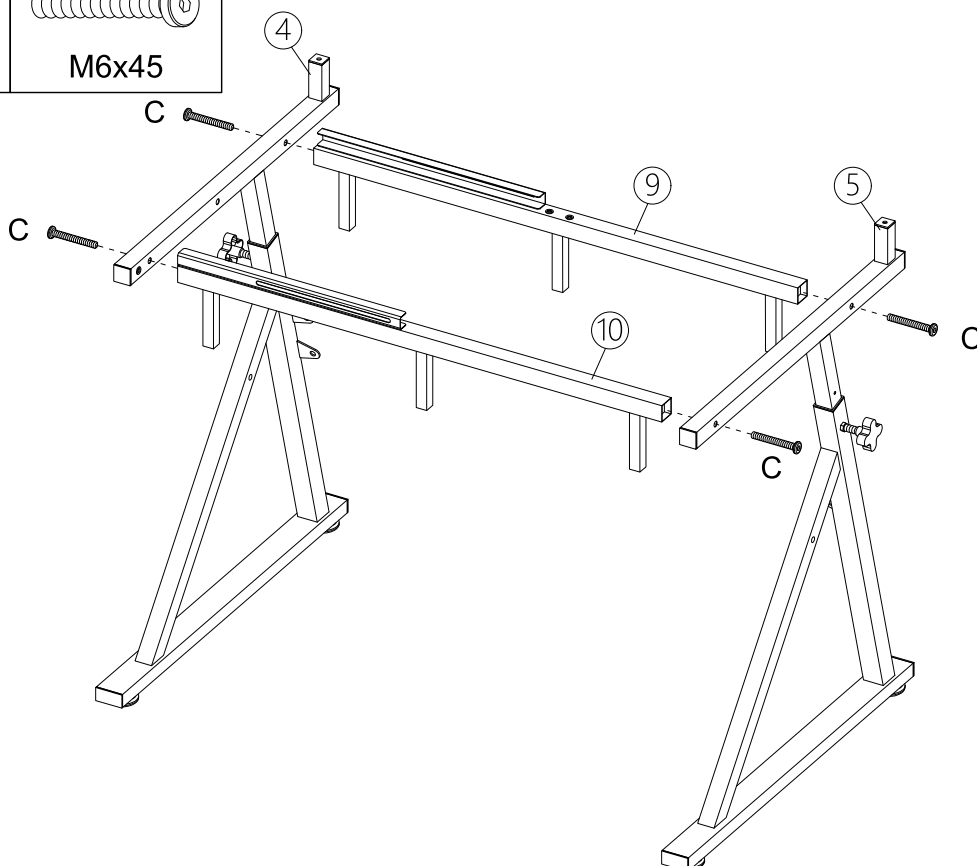
EN_ Components (5) and (4) need to be adjusted to the same height.
FR_ Les composants (5) et (4) doivent être réglés à la même hauteur.
ES_ Los componentes (5) y (4) deben ajustarse a la misma altura.
PT_ Os componentes (5) e (4) precisam ser ajustados na mesma altura.
DE_ Die Komponenten (5) und (4) müssen auf die gleiche Höhe eingestellt werden.
IT_ I componenti (5) e (4) devono essere regolati alla stessa altezza.
RO_ Componentele (5) și (4) trebuie reglate la aceeași înălțime.

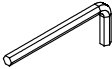
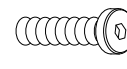
J	x 1	C	x 4
			
M4		M6x45	

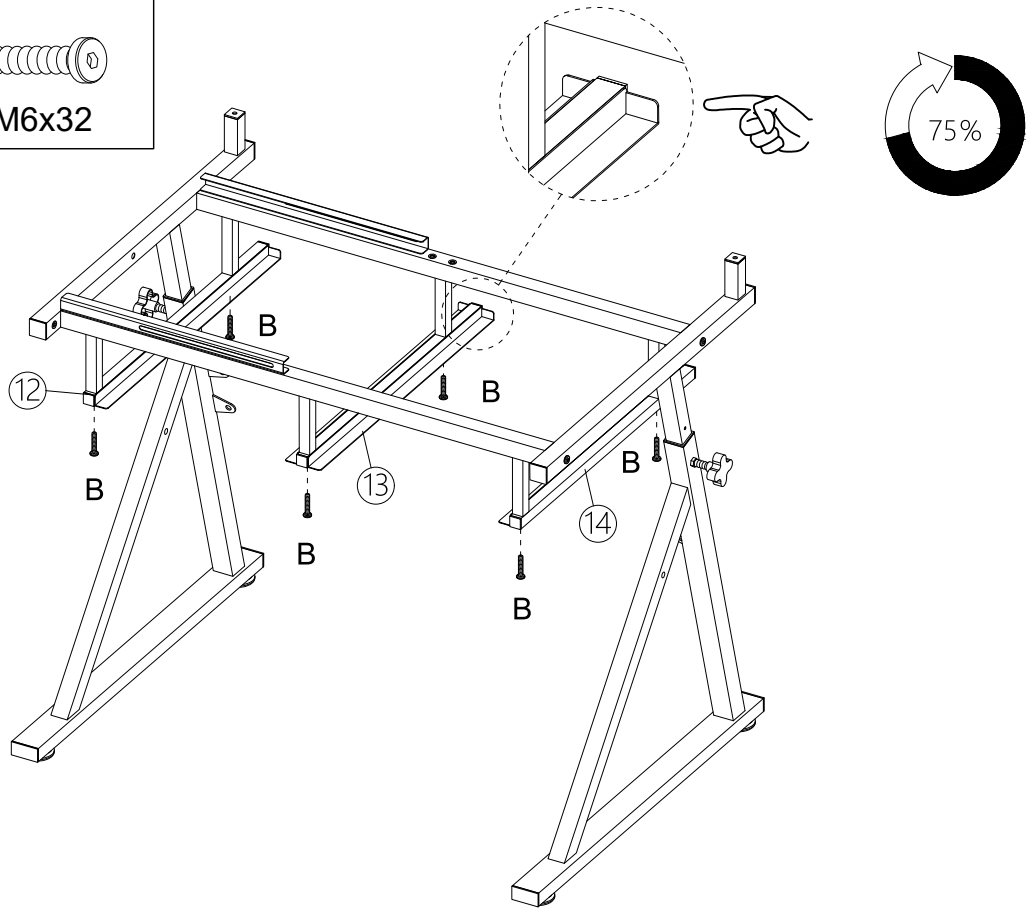

J	x 1	B	x 6
			
M4		M6x32	



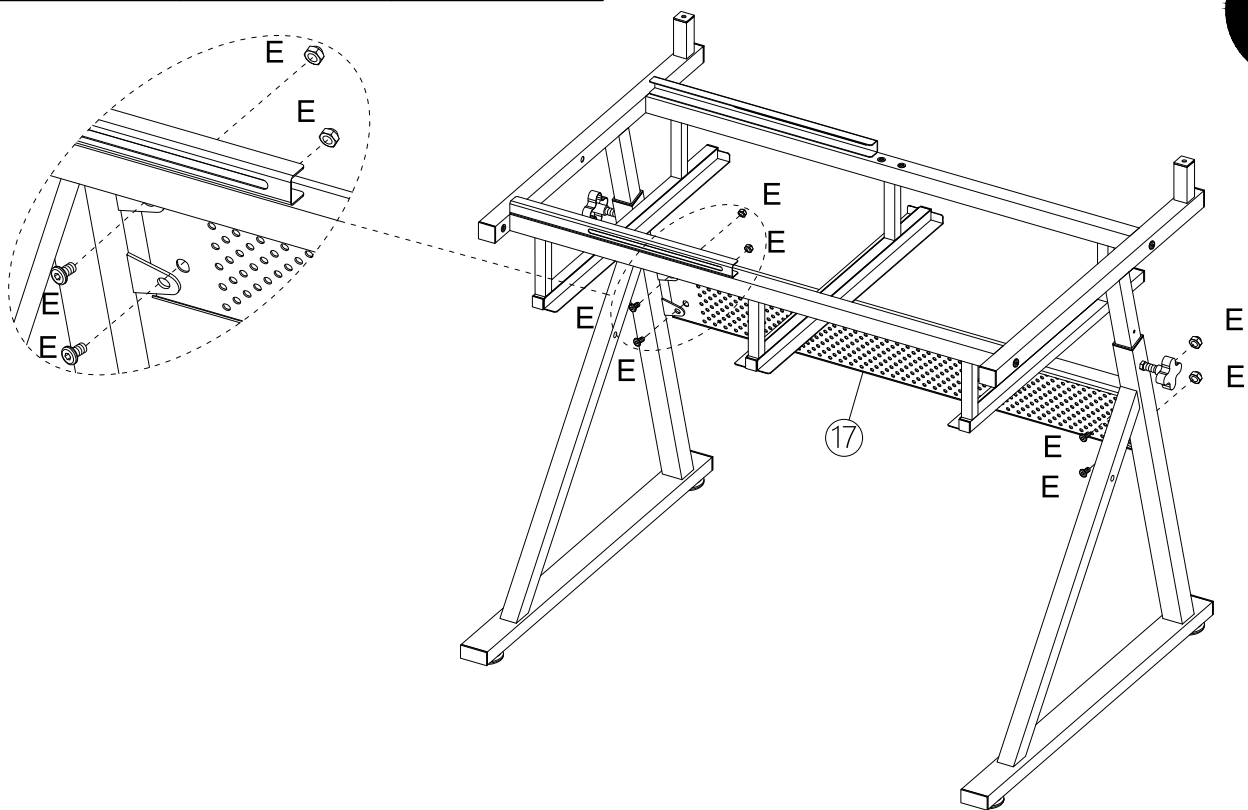

J	x 1	E	x 4	K	x 1
					
M4		M6x10	M6		

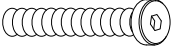

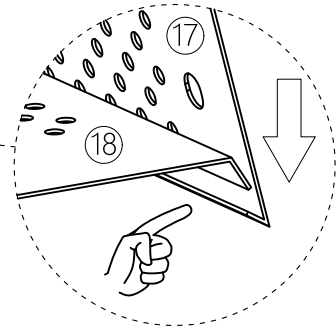
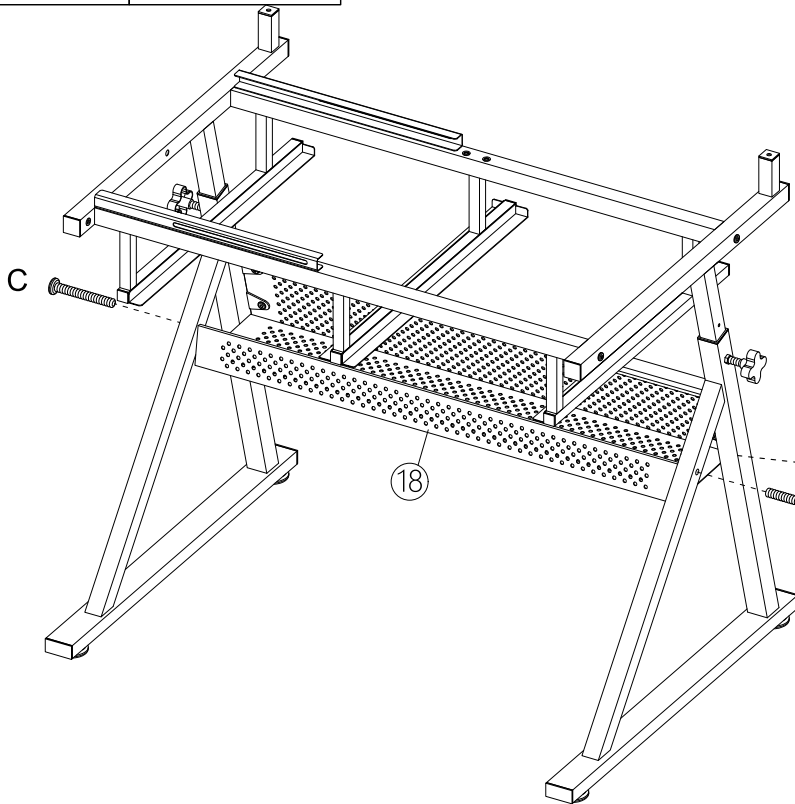
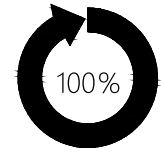
J	x 1	C	x 2
			
M4		M6x45	

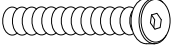

J	x 1	C	x 1	G	x 2
					
M4		M6x45		M6x15	

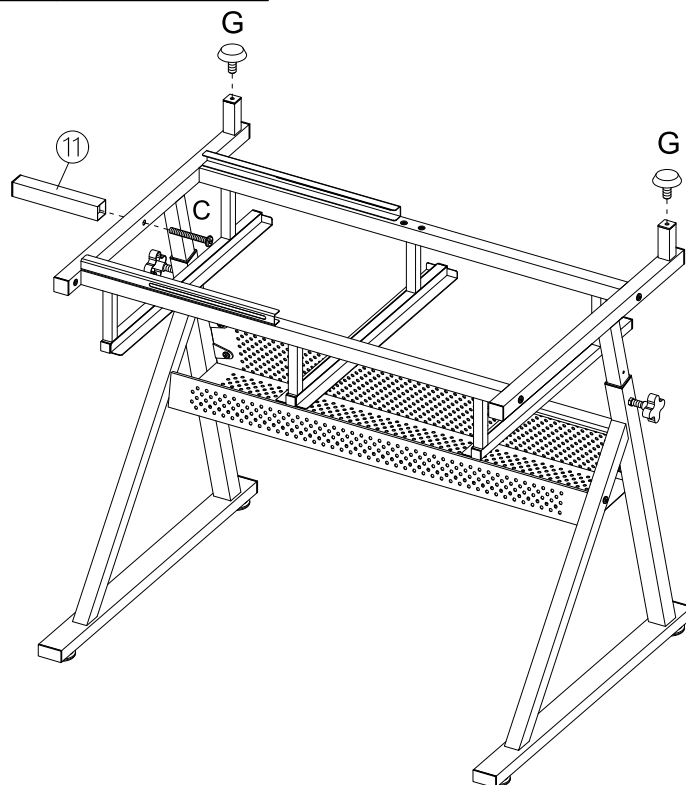
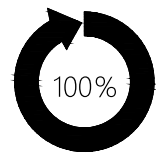

F x 2



M4x14

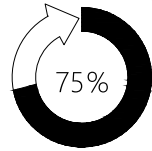
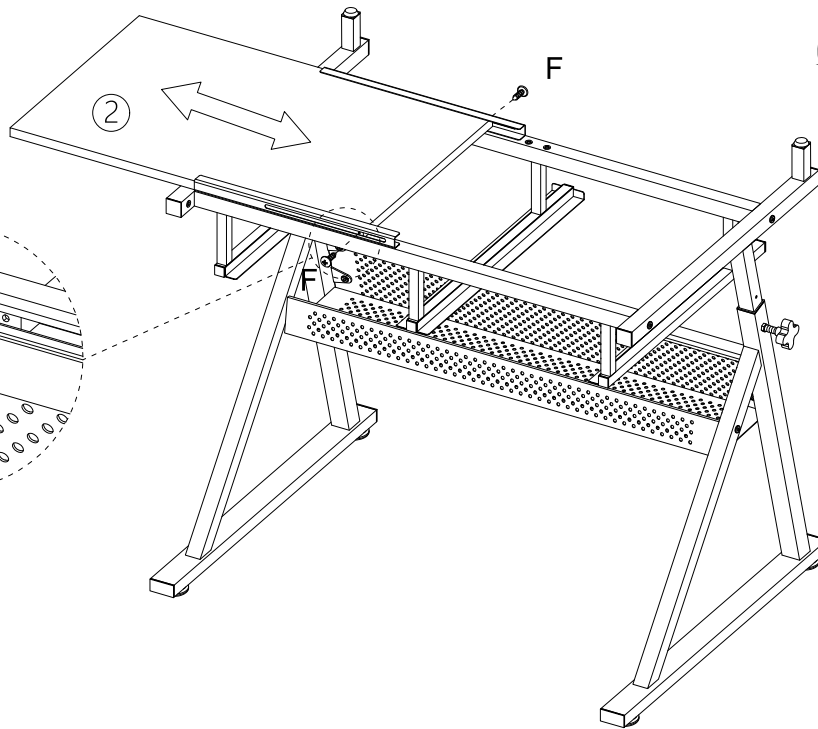
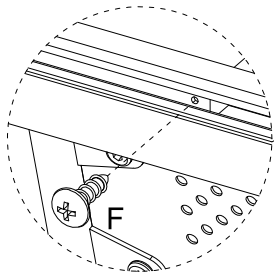

07

EN Please do not tighten the screws (F).
FR Ne serrez pas les vis (F).
ES No apriete los tornillos (F).
PT Não aperte os parafusos (F).
DE Bitte ziehen Sie die Schrauben (F) nicht fest.
IT Non serrare le viti (F).
RO Vă rugăm să nu strângeți șuruburile (F).

J x 1

A x 2

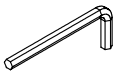

M4



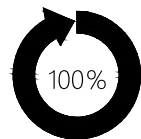
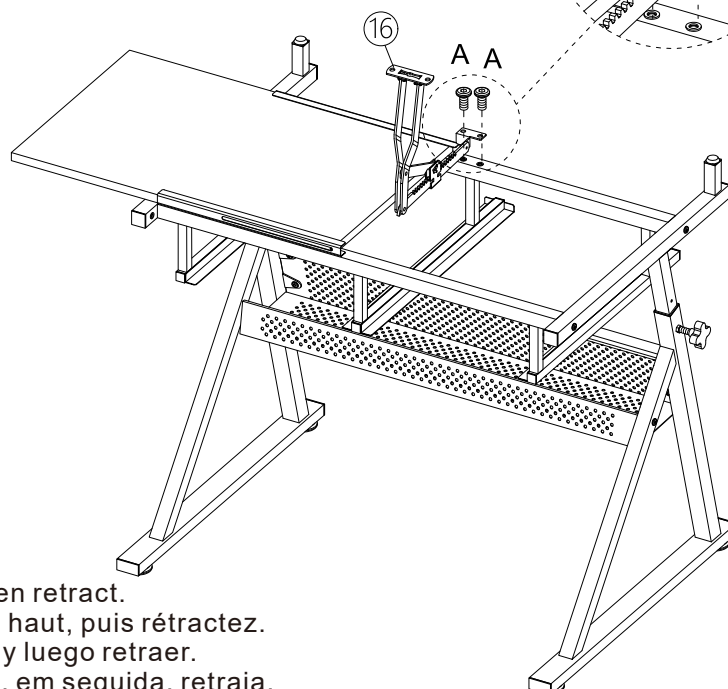
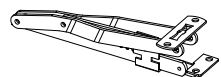
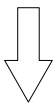
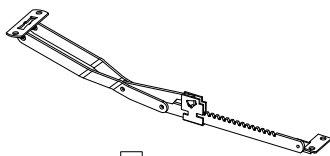

M6x12



08

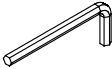

EN Open to the highest point, then retract.
FR Ouvrez jusqu'au point le plus haut, puis rétractez.
ES Abrir hasta el punto más alto y luego retraer.
PT Abra até ao ponto mais alto e, em seguida, retraia.
DE Öffnen Sie bis zum höchsten Punkt und fahren Sie dann zurück.
IT Aprire fino al punto più alto, quindi ritrarre.
RO Deschideți până la punctul cel mai înalt, apoi retrageți.

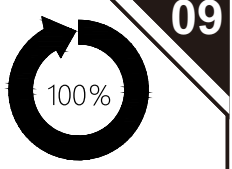
J	x 1	A	x 4	F	x 6
					
M4		M6x12		M4x14	

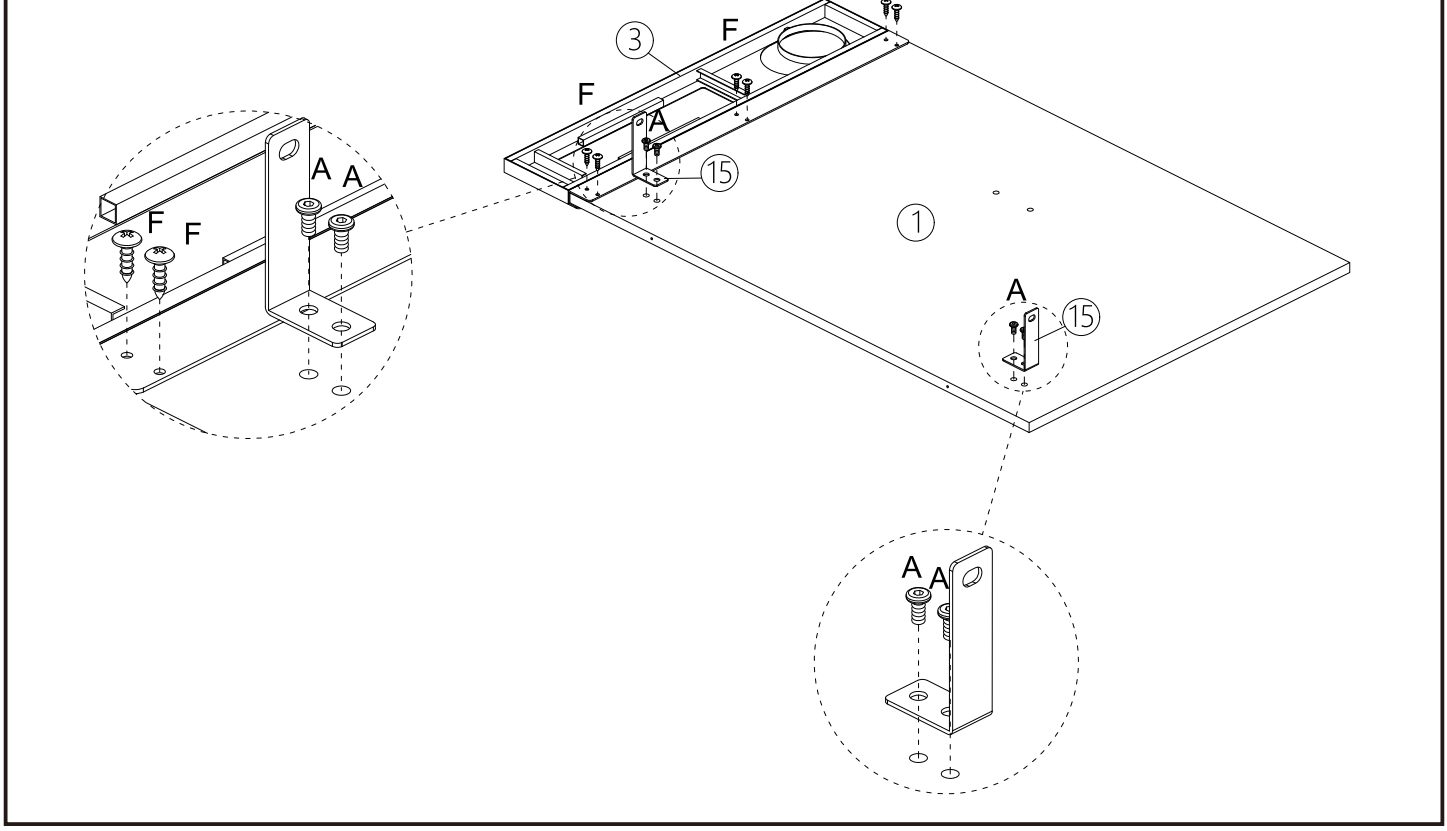

09



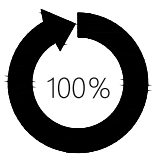

J	x 1	A	x 2
			
M4		M6x12	

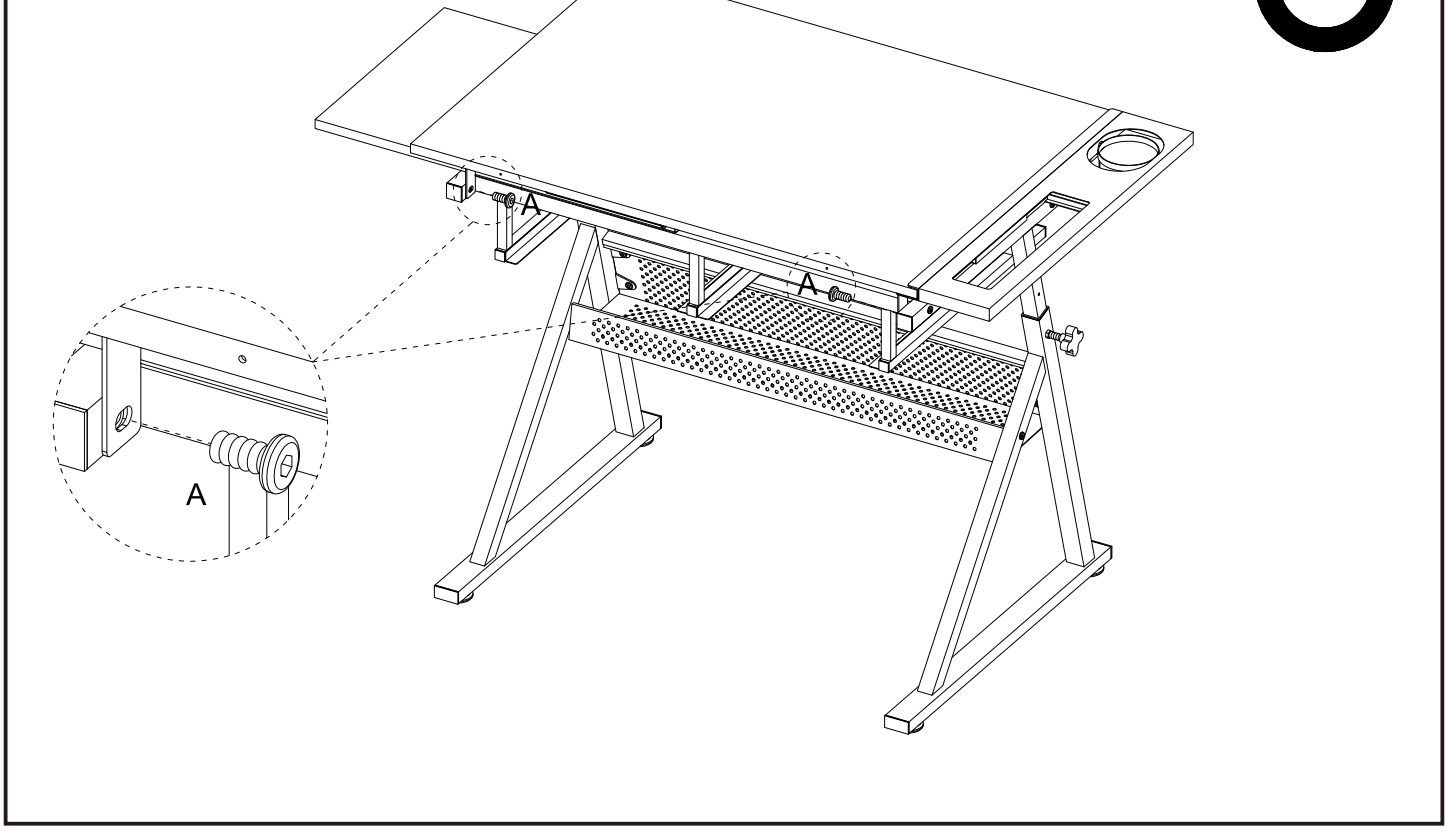

10

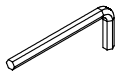

J	x 1	A	x 2
			
M4		M6x12	

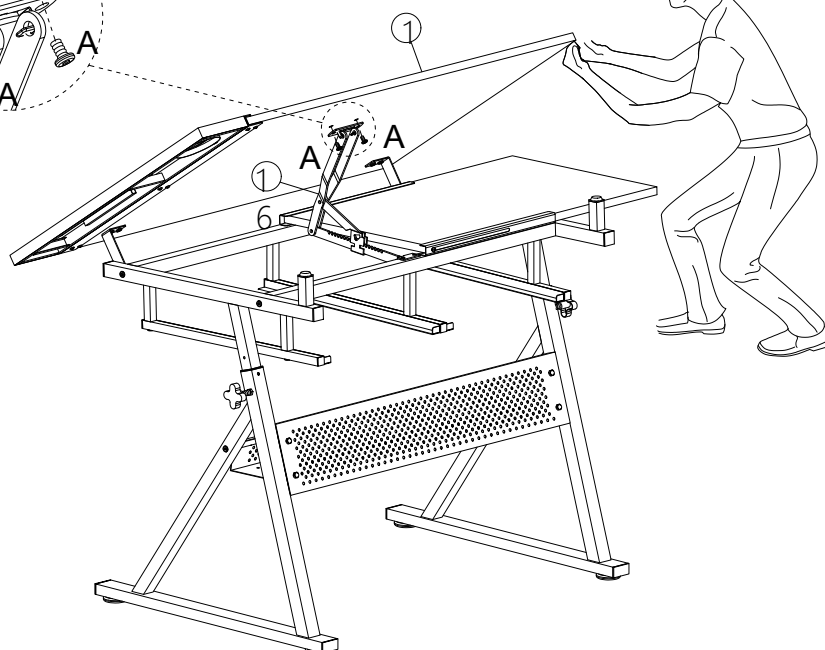
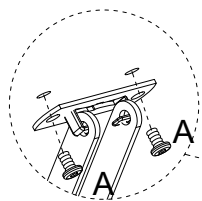
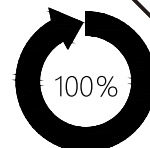

EN To prevent hand pinching, it is recommended that two people assemble this step.

FR Pour éviter de se pincer les doigts, il est recommandé d'être deux pour assembler cette étape.

ES Para evitar pellizcos en las manos, se recomienda que dos personas realicen este paso.

PT Para evitar beliscar as mãos, recomenda-se que duas pessoas realizem esta etapa.

DE Um ein Einklemmen der Hände zu vermeiden, wird empfohlen, diesen Schritt zu zweit durchzuführen.

IT Per evitare di schiacciarsi le mani, si consiglia di eseguire questa operazione in due persone.

RO Pentru a evita prinderea mâinilor, se recomandă ca această etapă să fie realizată de două persoane.

F	x 2
	
M4x14	

EN Please do not tighten the screws (F).

FR Ne serrez pas les vis (F).

ES No apriete los tornillos (F).

PT Não aperte os parafusos (F).

DE Bitte ziehen Sie die Schrauben (F) nicht fest.

IT Non serrare le viti (F).

RO Vă rugăm să nu strângeți șuruburile (F).

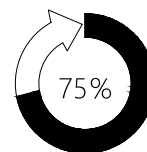
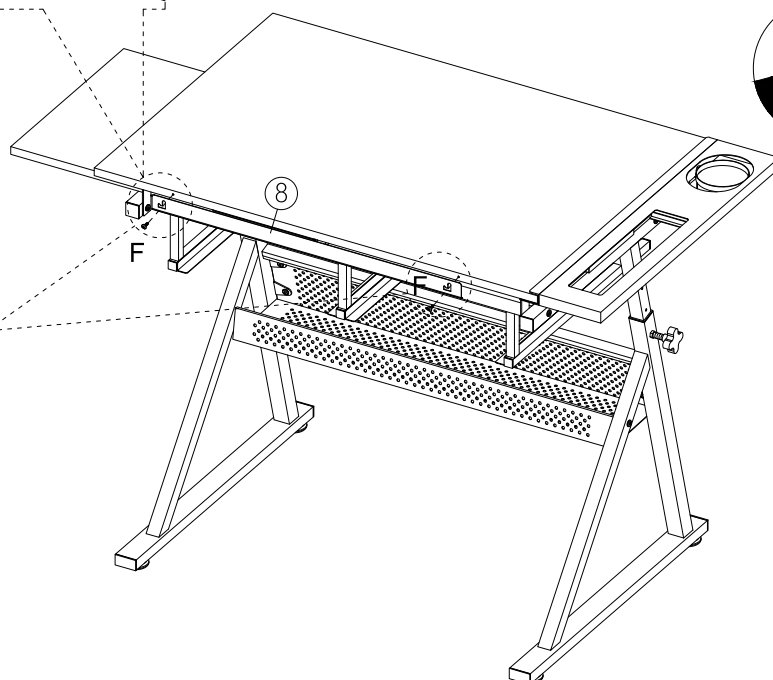
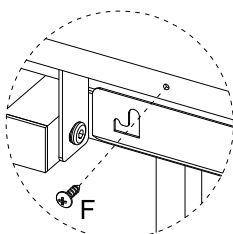
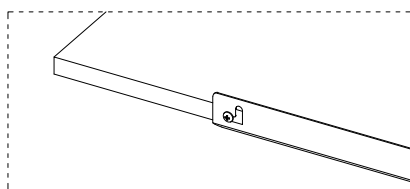

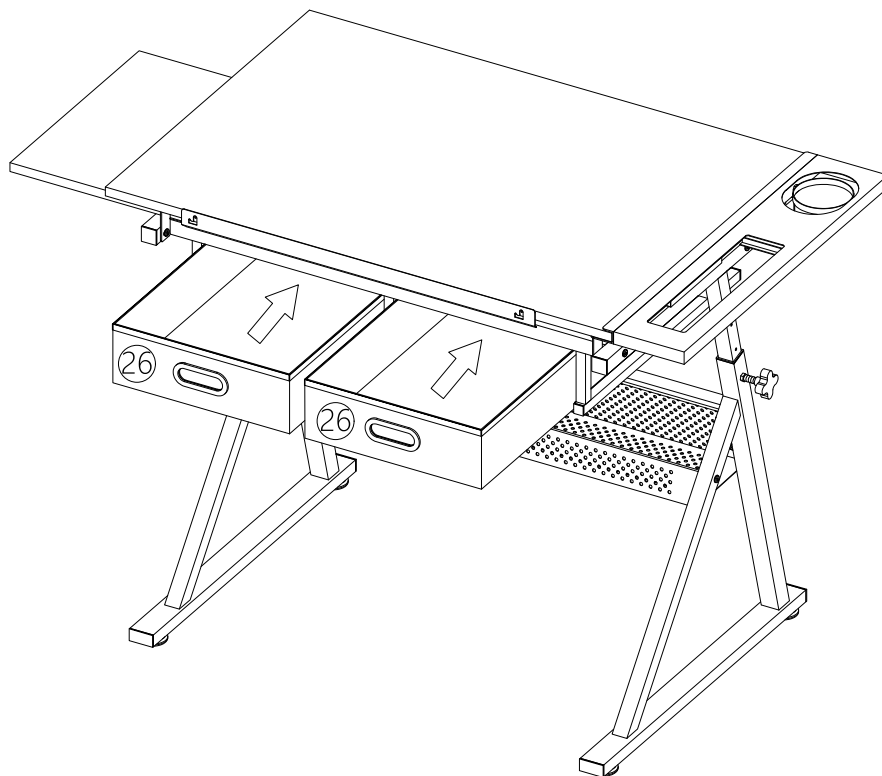
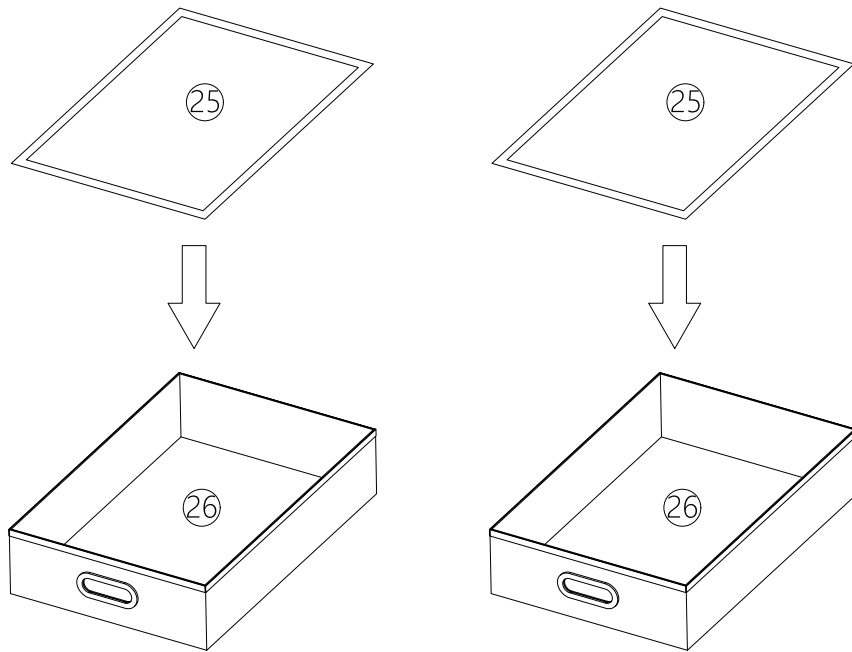

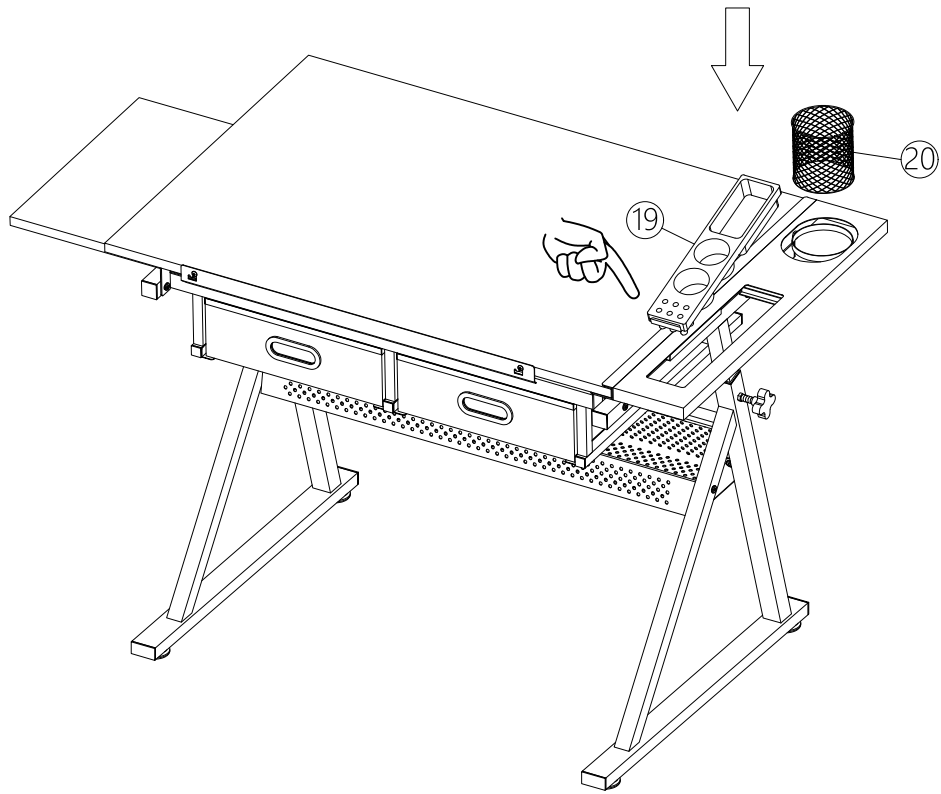

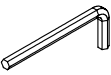
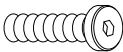

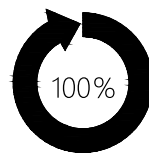
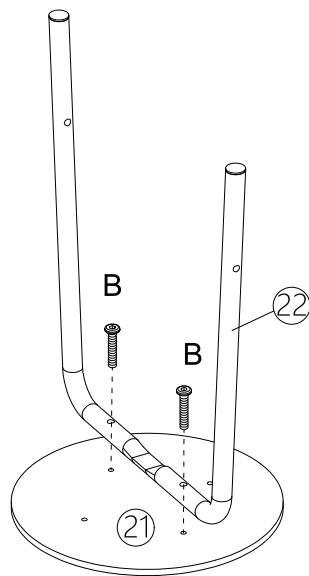
J	x 1	B	x 2
			
M4		M6x32	

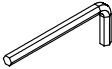
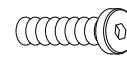

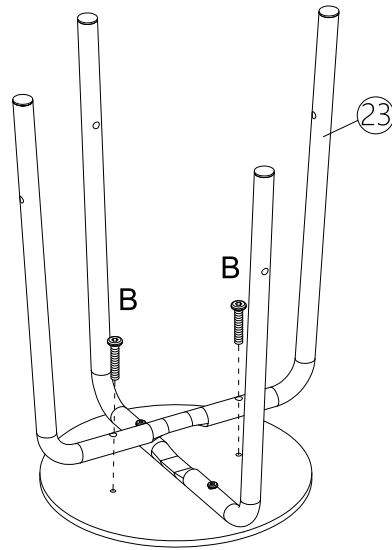
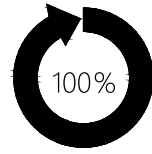
J	x 1	B	x 2
			
M4		M6x32	

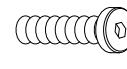
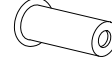

J	x 1	B	x 4	D	x 4
					
M4		M6x32		M6x20	

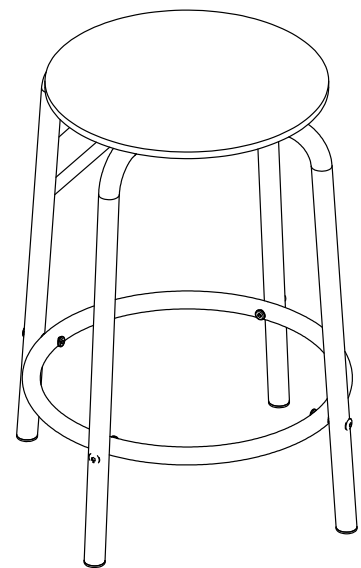
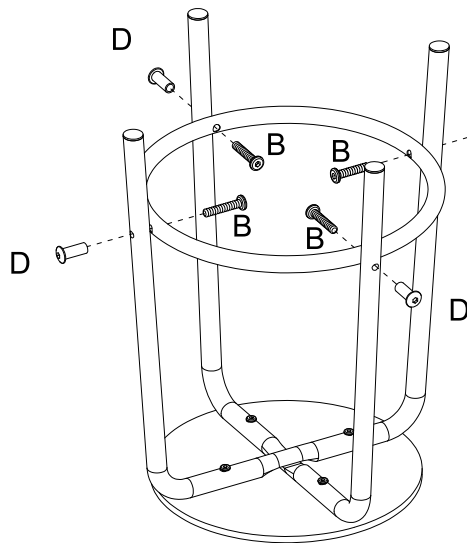
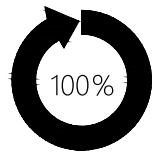

If you have any questions, please contact our customer care center, Our contact details are below:

US

 001-877-644-9366

 customerservice@aosom.com

Imported by Aosom LLC
7777 Center Ave. Suite 430
Huntington Beach, CA 92647-9998 USA
MADE IN CHINA

If you have any questions, please contact our customer care center, Our contact details are below:

CA

 416-792-6088

 customerservice@aosom.ca

Imported by Aosom Canada Inc.
Unit 33-1 Sparks Avenue, North York, Ontario,
Canada
M2H 2W1
MADE IN CHINA

Si vous avez la moindre question, veuillez contacter notre centre d'assistance à la clientèle, Nos coordonnées sont les suivantes:

 416-792-6088

 customerservice@aosom.ca

Importé par Aosom Canada Inc.
Unité 33-1 Sparks Avenue, North York, Ontario,
Canada M2H 2W1
Fabriqué en Chine

Si tiene alguna pregunta, comuníquese con nuestro Centro de Atención al Cliente, Nuestros datos de contacto son los siguientes:

ES

 0034-931294512

 atencioncliente@aosom.es

IMPORTADOR/Fabricante/REP:
SPANISH AOSOM, S.L.
C/ROC GROS, Nº15.08550, ELS HOSTALET DE
BALENYÀ, SPAIN.
B66295775
HECHO EN CHINA

Se tiver alguma dúvida, por favor contacte o nosso Centro de Atendimento ao Cliente, Os nossos dados de contacto são os seguintes:

 0034-931294512

 info@aosom.pt.

Si vous avez la moindre question, veuillez contacter notre centre d'assistance à la clientèle, Nos coordonnées sont les suivantes:

FR

 0033-1-84166106

 aosom@mhfrance.fr

Importé par/Fabricant/REP:
MH FRANCE
2 Rue Maurice Hartmann
92130 Issy Les Moulineaux
France
FABRIQUÉ EN CHINE



FR

**DONNEZ
OU
RECYCLEZ**



ASSOCIATION

OU



LIVRAISON

OU



DÉCHÈTERIE

Adresses sur quefairedemesdechets.fr

If you have any questions, please contact our customer care center, Our contact details are below:

UK

 0044-800-240-4004

 enquiries@mhstar.co.uk

IMPORTER ADDRESS:
MH STAR UK LTD
1 Northampton Cross Logistics Park
Northampton Cross Road
Northampton
Nn4 9FH
Tel: 0800 240 4050
enquiries@mhstar.co.uk
MADE IN CHINA

Wenn Sie Fragen haben, wenden Sie sich bitte an unser Kundendienstzentrum, Unsere Kontaktdaten stehen unten:

DE

 0049-0(40)-87408465

 service@aosom.de

ADRESSE DES IMPORTEURE/Hersteller/REP:
MH Handel GmbH
Wendenstraße 309
D-20537 Hamburg
Germany
IN CHINA HERGESTELLT

In caso di dubbio, si prega di contattare il nostro centro assistenza clienti, I nostri dettagli di contatto sono di seguito:

IT

 0039-0249471447

 clienti@aosom.it

IMPORTATO DA/Produttore/REP:
AOSOM Italy srl
Centro Direzionale Milanofiori
Strada 1 Palazzo F1
20057 Assago (MI)
P.I.: 08567220960
FATTO IN CINA

Importator/Producător/REP:

RO

Aosom Romania SRL
Str. Barbu Mumuleanu, nr. 30-32
Bucuresti, Sector 2
Tel: +40 312294730
clienti@aosom.ro
Fabricat in China