

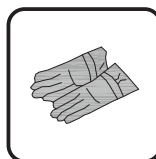

IN251100242V02_GL

84H-542V00

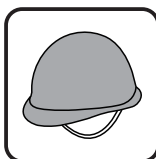
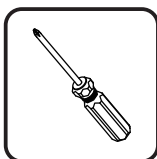
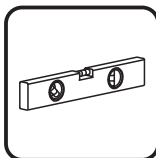
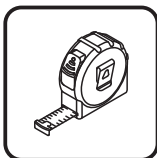
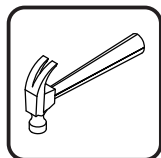
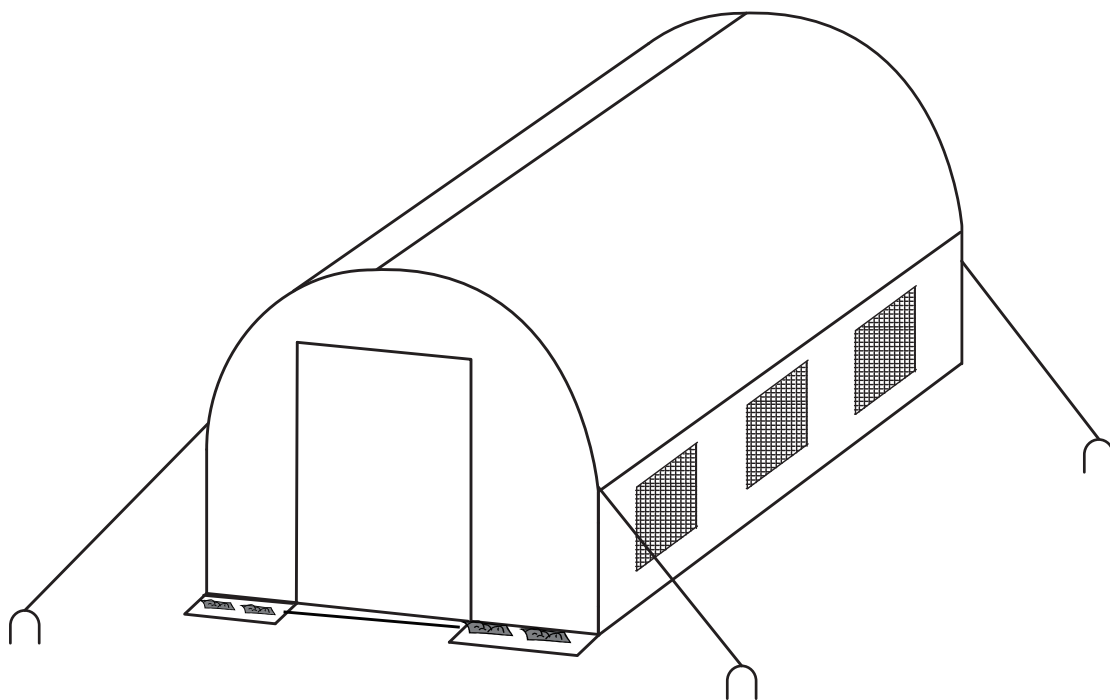

14
STEPS

2 HR



Tools Recommended

EN_IMPORTANT, RETAIN FOR FUTURE REFERENCE: READ CAREFULLY.

FR_IMPORTANT : A LIRE ATTENTIVEMENT ET A CONSERVER POUR VOUS Y REFERER ULTERIEUREMENT

ES_IMPORTANTE, LEA Y GUARDE PARA FUTURAS REFERENCIAS.

PT_IMPORTANTE, RETAR PARA REFERÉNCIA FUTURA: LEIA ATENTAMENTE.

DE_WICHTIG! SORGFÄLTIG LESEN UND FÜR SPÄTER NACHSCHLAGEN AUFBEWAHREN.

IT_IMPORTANTE! CONSERVARE IL PRESENTE MANUALE PER FUTURO RIFERIMENTO E LEGGERLO ATTENTAMENTE.

RO_IMPORTANT, PĂSTRAȚI PENTRU REFERINȚĂ VIITOARE: CITIȚI CU ATENȚIE.

EN**IMPORTANT SAFETY NOTICE**

Product is NOT INTENDED for the following:

- A safety barrier to prevent unsupervised access to pools, hot tubs, spas or ponds.
- As load bearing support for a building, structure, heavy objects or swings.
- Used in structures that trap wind, rain or snow that would create extra load on the product.

Accumulated snow must be removed from roof.

DO NOT climb or walk on roof for any reason.

Wear gloves to avoid injury from possible sharp edges of individual elements before assembly.

During installation, follow all safety warnings provided with your tools.

Some structures may require two or more people to install safely.

Check for underground utilities before digging or driving stakes into the ground!

It is important during assembly to closely follow the instructions, complete the assembly on a solid level surface and that you follow the instruction to square up, level and anchor the structure, this will reduce the gap at connections during assembly.

FR**AVIS IMPORTANT DE SÉCURITÉ**

Le produit n'est PAS DESTINÉ à ce qui suit :

- Une barrière de sécurité pour empêcher l'accès non surveillé aux piscines, aux spas, aux cuves thermales ou aux étangs.
- Comme support de charge pour un bâtiment, une structure, des objets lourds ou des balançoires.
- Utilisé dans des structures qui retiennent le vent, la pluie ou la neige qui créeraient une charge supplémentaire sur le produit.

La neige accumulée doit être enlevée du toit.

NE PAS grimper ou marcher sur le toit pour quelque raison que ce soit.

Portez des gants pour éviter les blessures causées par d'éventuels bords tranchants des composants avant de procéder à l'assemblage.

Lors de l'installation, respectez tous les avertissements de sécurité fournis avec vos outils.

Certaines structures peuvent nécessiter l'intervention de deux personnes ou plus pour les installer en toute sécurité.

Vérifiez la présence de services publics souterrains avant de creuser ou de planter des piquets dans le sol !

Il est important, pendant tout le processus de montage, de suivre attentivement les instructions, de terminer l'assemblage sur une surface solide et plane et de suivre les instructions d'équerrage, de mise à niveau et d'ancrage de la structure, ce qui permettra de réduire les écarts au niveau des liaisons pendant le montage.

ES**AVISO IMPORTANTE DE SEGURIDAD**

Manténgase alejado de las líneas eléctricas aéreas.

No coloque ni instale su tienda de campaña debajo de los árboles debido a posibles rayos o hundimiento de las ramas de los árboles en condiciones climáticas adversas. Para obtener las mejores condiciones en caso de viento fuerte, coloque el extremo estrecho de la tienda en la dirección del viento.

No dejes caer la tienda de campaña.

No haga rebotar ni golpee la bolsa de la tienda para sacarla, estas acciones podrían dañar el marco.

ESTE PRODUCTO REQUIERE UN MÍNIMO DE DOS PERSONAS PARA SU MONTAJE

Bajo ninguna circunstancia se debe utilizar este producto para cubrir automóviles, vehículos marinos o artículos similares.

PRECAUCIÓN: Vigile no pellizcarse los dedos durante el montaje y desmontaje de la tienda al unir las piezas del marco.

AVISO DE SEGURANÇA IMPORTANTE

O produto NÃO é DESTINADO ao seguinte:

- Uma barreira de segurança para impedir o acesso sem supervisão a piscinas, banheiras, spas ou lagos.
- Como suporte de carga para um edifício, estrutura, objectos pesados ou baloiços.
- Usado em estruturas que apanham vento, chuva ou neve que criariam carga extra sobre o produto.

A neve acumulada deve ser removida do telhado. NÃO subir ou caminhar no telhado por qualquer razão.

Usar luvas para evitar ferimentos causados por possíveis arestas vivas de elementos individuais antes da montagem.

Durante a instalação, siga todos os avisos de segurança fornecidos com as suas ferramentas. Algumas estruturas podem exigir a instalação segura de duas ou mais pessoas. Verifique a existência de utilidades subterrâneas antes de escavar ou de conduzir estacas no solo!

É importante durante a montagem seguir de perto as instruções, completar a montagem numa superfície sólida e nivelar e ancorar a estrutura, o que reduzirá a folga nas ligações durante a montagem.

WICHTIGER SICHERHEITSHINWEIS

Das Produkt ist NICHT für einen der folgenden Anwendungen bestimmt:

- Als Sicherheitsbarriere, die den unbeaufsichtigten Zugang zu Pools, Whirlpools, Spas oder Teichen verhindert.
- Als tragende Stütze für ein Gebäude, eine Struktur, schwere Gegenstände oder Schaukeln.
- Als Bestandteil einer Struktur verwendet werden, welche Wind, Regen oder Schnee abfangen, die eine zusätzliche Belastung für das Produkt darstellen würden.

Angesammelter Schnee muss vom Dach entfernt werden.

Aus keinem Grund darf das Dach bestiegen oder betreten werden.

Bitte tragen Sie stets geeignete Arbeitshandschuhe, um Verletzungen durch mögliche scharfe Kanten einzelner Elemente während der Montage zu vermeiden.

Befolgen Sie während des Installationsprozesses bitte sorgfältig alle Sicherheitswarnungen, die mit Ihren Werkzeugen geliefert werden.

Einige Strukturen können zwei oder mehr Personen erfordern, um sicher installiert zu werden.

Prüfen Sie vor dem Graben oder Eintreiben von Pfählen in den Boden, ob Erdkabel vorhanden sind!

Es ist wichtig, während der Montage die Anweisungen genau zu befolgen, Ihr Produkt auf einem festen und ebenen Untergrund aufzustellen und die Anweisung zum Aufrichten, Nivellieren und Verankern der Struktur zu befolgen, da dadurch der Spalt an den Verbindungen während der Montage verringert wird.

IMPORTANTI PRECAUZIONI DI SICUREZZA

Il prodotto NON è PROGETTATO per quanto segue:

- Una barriera di sicurezza per impedire l'accesso senza supervisione a piscine, vasche idromassaggio, spa o stagni.
- Supporto portante di edifici, strutture, oggetti pesanti o altalene.
- Parte di strutture che accumulano vento, pioggia o neve, in quanto creerebbero un carico extra sul prodotto.

La neve accumulata deve essere rimossa dal tetto.

NON salire o camminare sul tetto per nessun motivo.

Indossare guanti per evitare lesioni derivanti da spigoli vivi dei singoli componenti prima del montaggio.

Durante l'installazione, seguire tutte le precauzioni di sicurezza fornite con gli strumenti.

Alcune strutture possono richiedere due o più persone per essere installate in sicurezza.

Controlla le utenze sotterranee prima di scavare o piantare pali nel terreno!

È importante che durante il montaggio vengano seguite attentamente le istruzioni, inoltre completare il montaggio su una superficie piana e solida e seguire le istruzioni per allineare, livellare e ancorare la struttura, in quanto questo ridurrà lo spazio necessario durante il montaggio.

AVIZ IMPORTANT DE SIGURANȚĂ

Produsul NU ESTE DESTINAT următoarelor utilizări:

- Ca barieră de siguranță pentru a împiedica accesul nesupravegheat la piscine, căzi cu hidromasaj, spa-uri sau iazuri.
- Ca suport portant pentru clădiri, structuri, obiecte grele sau leagăne.
- Utilizarea în structuri care rețin vântul, ploaia sau zăpada, ceea ce ar genera o sarcină suplimentară asupra produsului.

Zăpada acumulată trebuie îndepărtată de pe acoperiș.

NU vă urcați și nu mergeți pe acoperiș sub niciun motiv.



Purtați mănuși pentru a evita rănirea cauzată de eventualele margini ascuțite ale elementelor individuale înainte de asamblare.





În timpul instalării, respectați toate avertismentele de siguranță furnizate împreună cu uneltele.

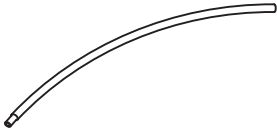
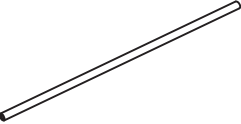
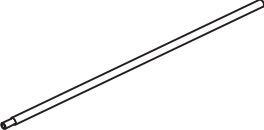
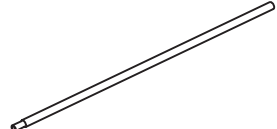
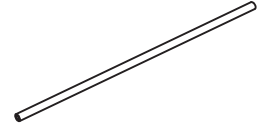
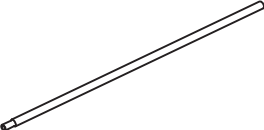

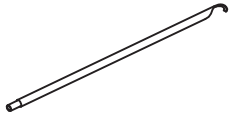

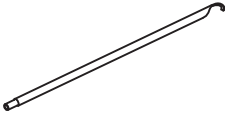
Unele structuri pot necesita două sau mai multe persoane pentru a fi instalate în siguranță.

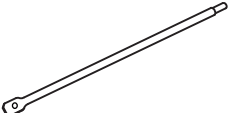

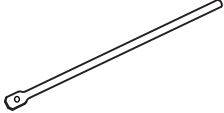
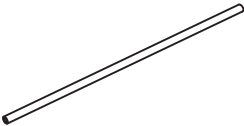
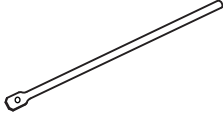
Verificați dacă există utilități subterane înainte de a săpa sau de a înfige țărugi în pământ!

În timpul asamblării, este important să urmați cu atenție instrucțiunile, să finalizați asamblarea pe o suprafață solidă și plană și să urmați instrucțiunile de aliniere, nivelare și ancorare a structurii; acest lucru va reduce spațiul de la îmbinări în timpul asamblării.

Item no.	Reference Image	Qty
①		X16
②		X19
③		X32
③-1		X8
④		X4
⑤		X4
⑥		X2
⑥-1		X2
⑦		X2

Item no.	Reference Image	Qty
⑦-1		X2
⑧		X2
⑨		X4
⑪		X16
⑫		X4
⑬		X4
⑭		X2

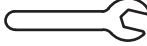
Item no.	Reference Image	Qty
(A)	 m6x45mm	X112
(B)	 m6x25mm	X20
(C)		X58
(D)		X4
(PE)		X1

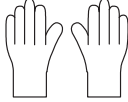
Item no.	Reference Image	Qty
(E)		X4
(F)		X1
(G)		X1
(H)		X28
(I)		X1

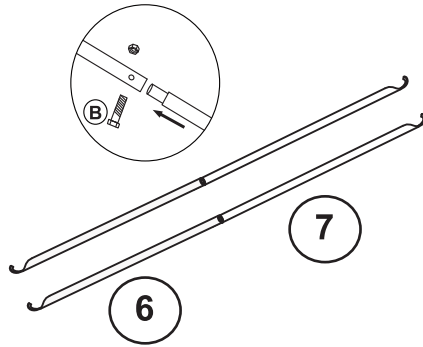

EN_Connecting 6 and 7
 FR_Assembler les pièces 6 et 7.
 DE_Verbinden Sie 6 und 7.
 ES_Conecte los elementos 6 y 7.
 PT_Ligar os tubos 6 e 7.
 IT_Collegare i punti 6 e 7.
 RO_Conectați 6 și 7.

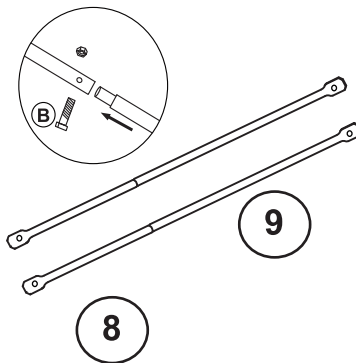

EN_Connecting 6 and 7
 FR_Assembler les pièces 6 et 7.
 DE_Verbinden Sie 6 und 7.
 ES_Conecte los elementos 6 y 7.
 PT_Ligar os tubos 6 e 7.
 IT_Collegare i punti 6 e 7.
 RO_Conectați 6 și 7.

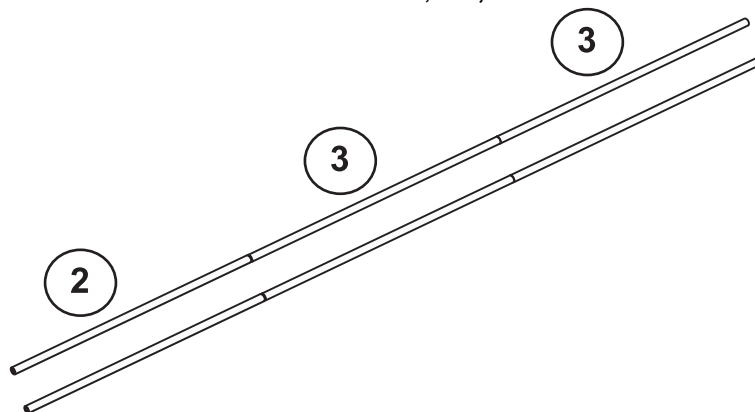

EN_Connecting 2, 3 and 3.
 FR_Assembler les pièces 2, 3 et 3.
 DE_Verbinden Sie 2, 3 und 3.
 ES_Conecte los elementos 2, 3 y 3.
 PT_Ligar os tubos 2, 3 e 3.
 IT_Collegare i punti 2, 3 e 3.
 RO_Conectați 2, 3 și 3.

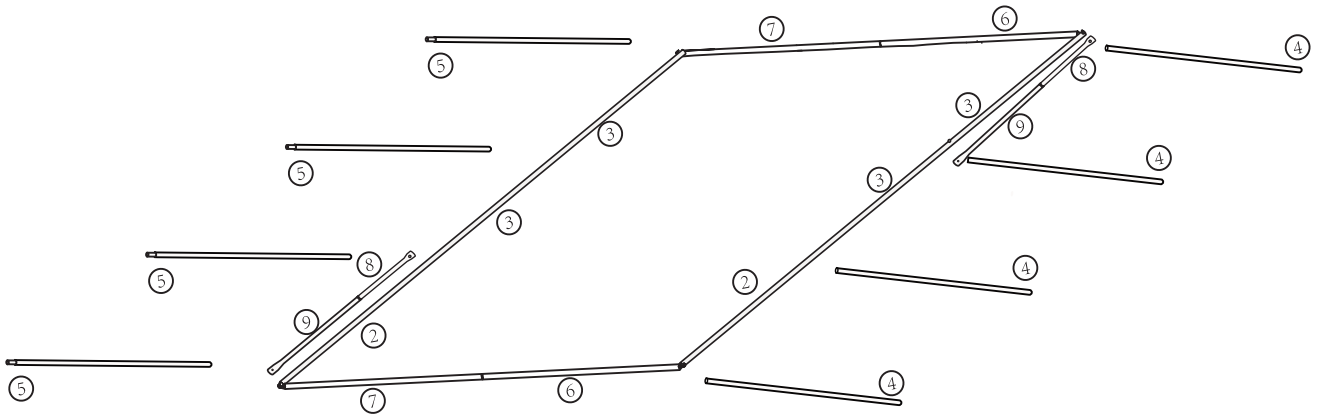

EN_Picking out 4 (4PCS) and 5 (4PCS) and putting them to the right position.

FR_Prendre les pièces 4 (4 pièces) et 5 (4 pièces) et les placer dans la bonne position.

DE_Nehmen Sie 4 (4 Stück) und 5 (4 Stück) heraus und bringen Sie sie in die richtige Position.

ES_Seleccione los elementos 4 (4 unidades) y 5 (4 unidades) y colóquelos en la posición correcta.

PT_Retirar os tubos 4 (4 unidades) e 5 (4 unidades) e colocá-los na posição correta.

IT_Prelevare i pezzi 4 (4 pezzi) e 5 (4 pezzi) e posizzionarli correttamente.

RO_Alegeți piesele 4 (4 buc.) și 5 (4 buc.) și așezați-le în poziția corectă.

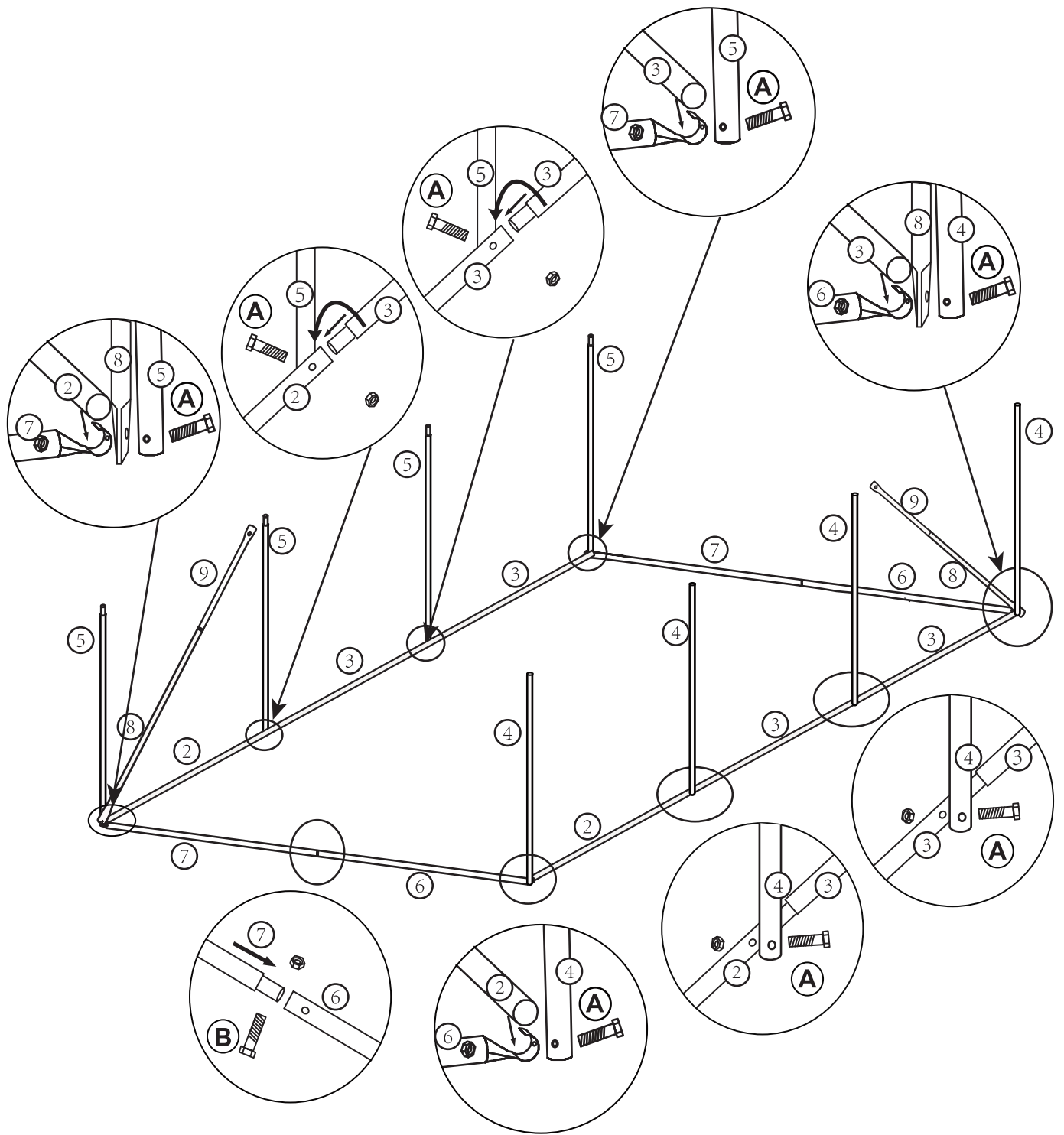

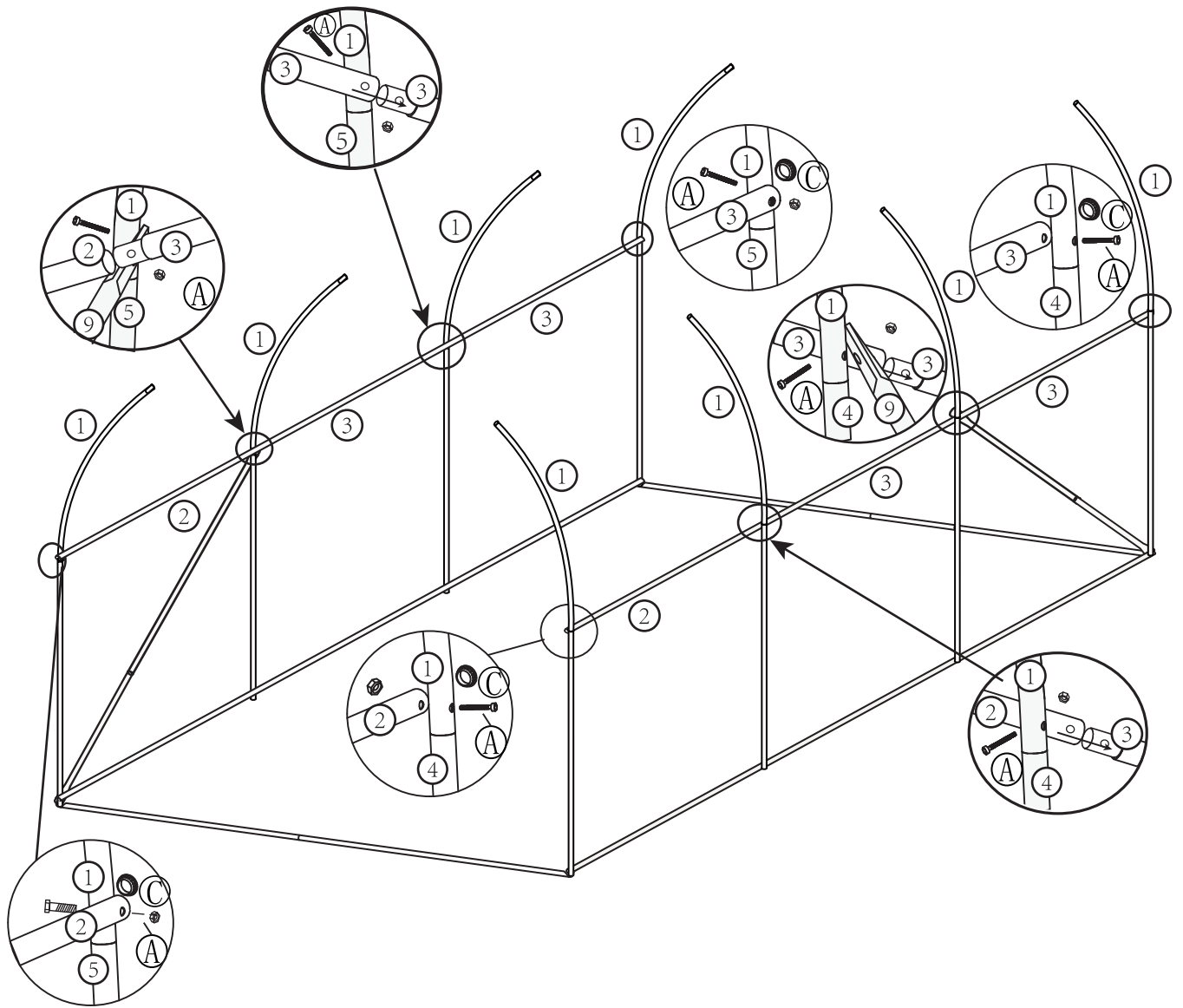

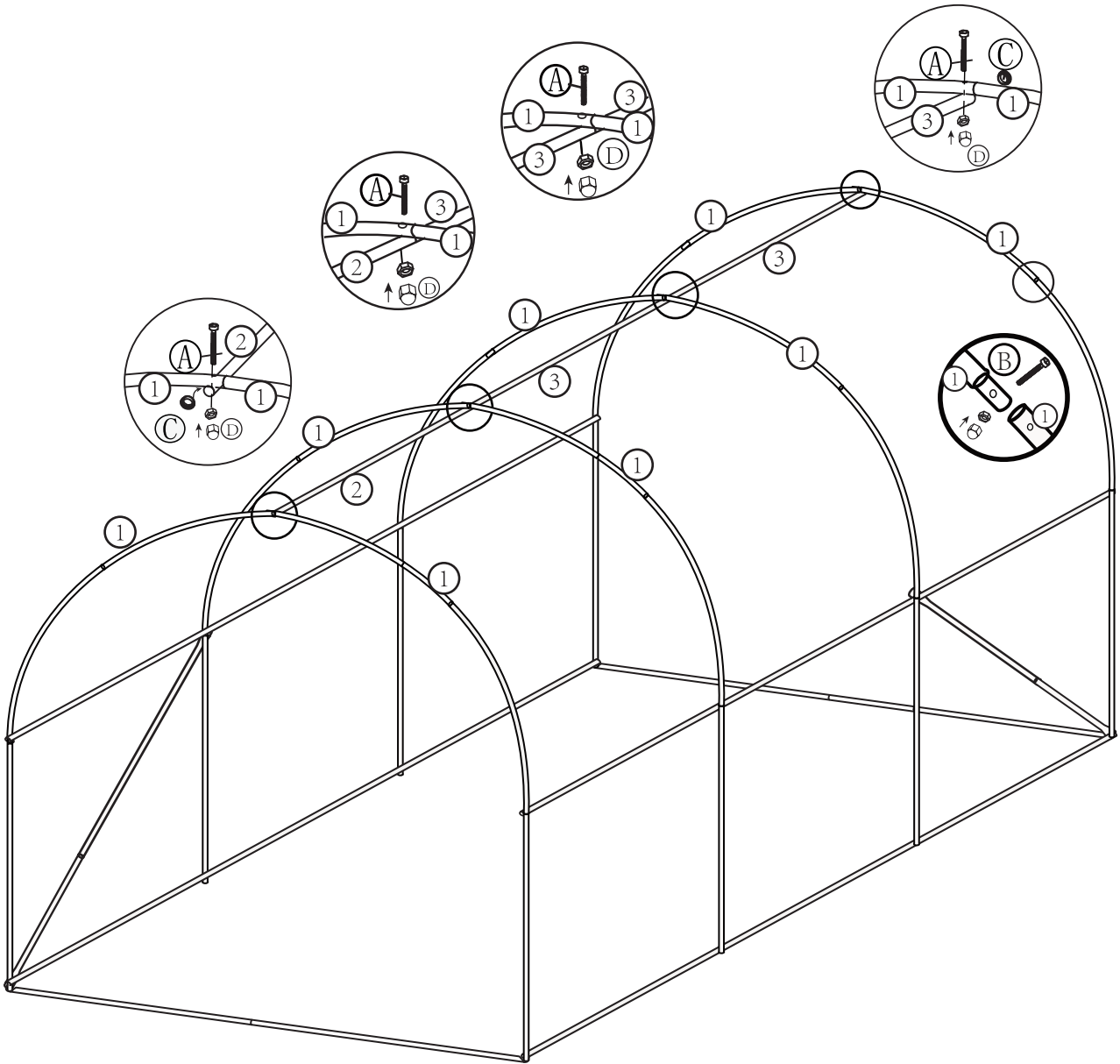

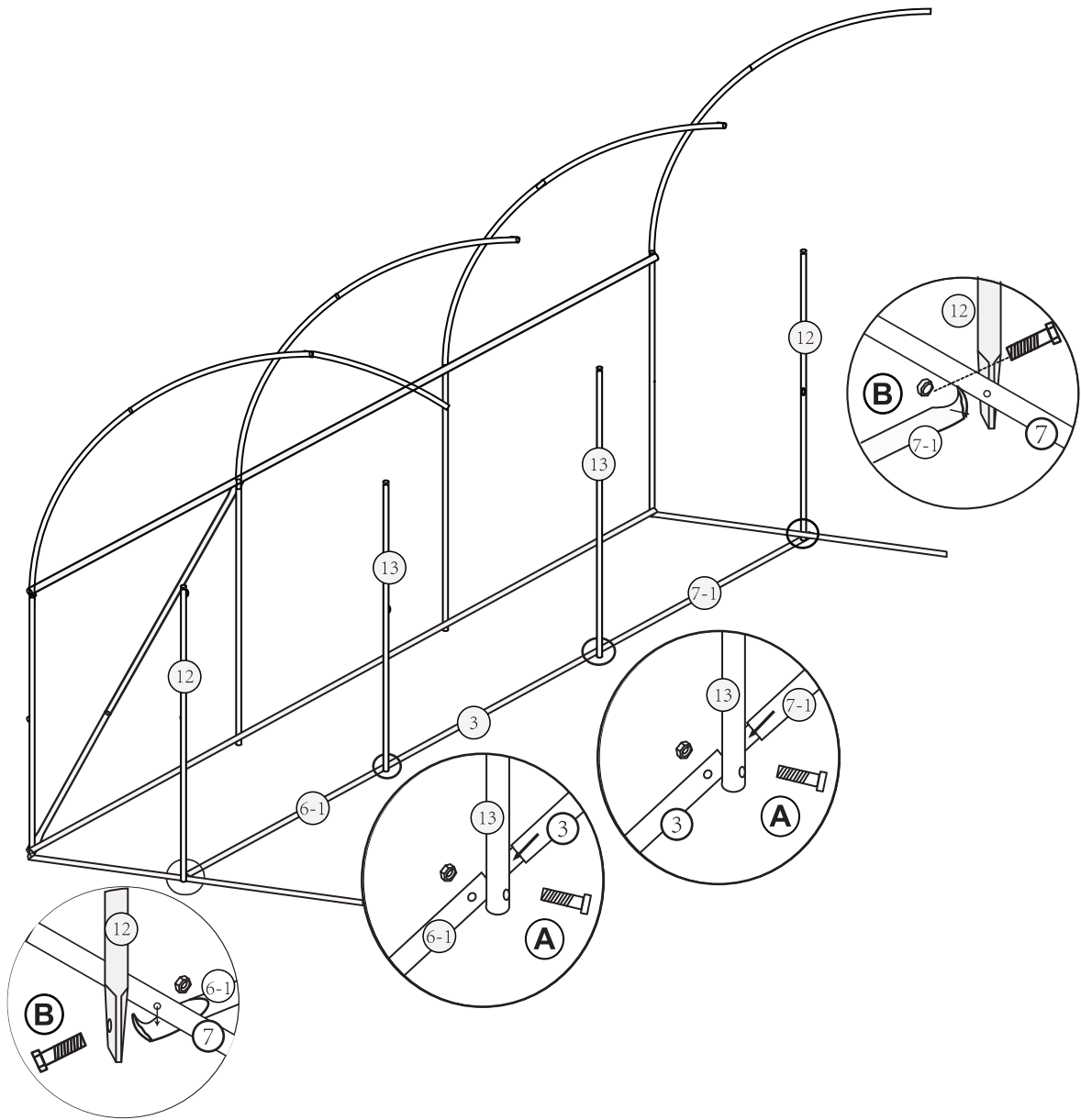

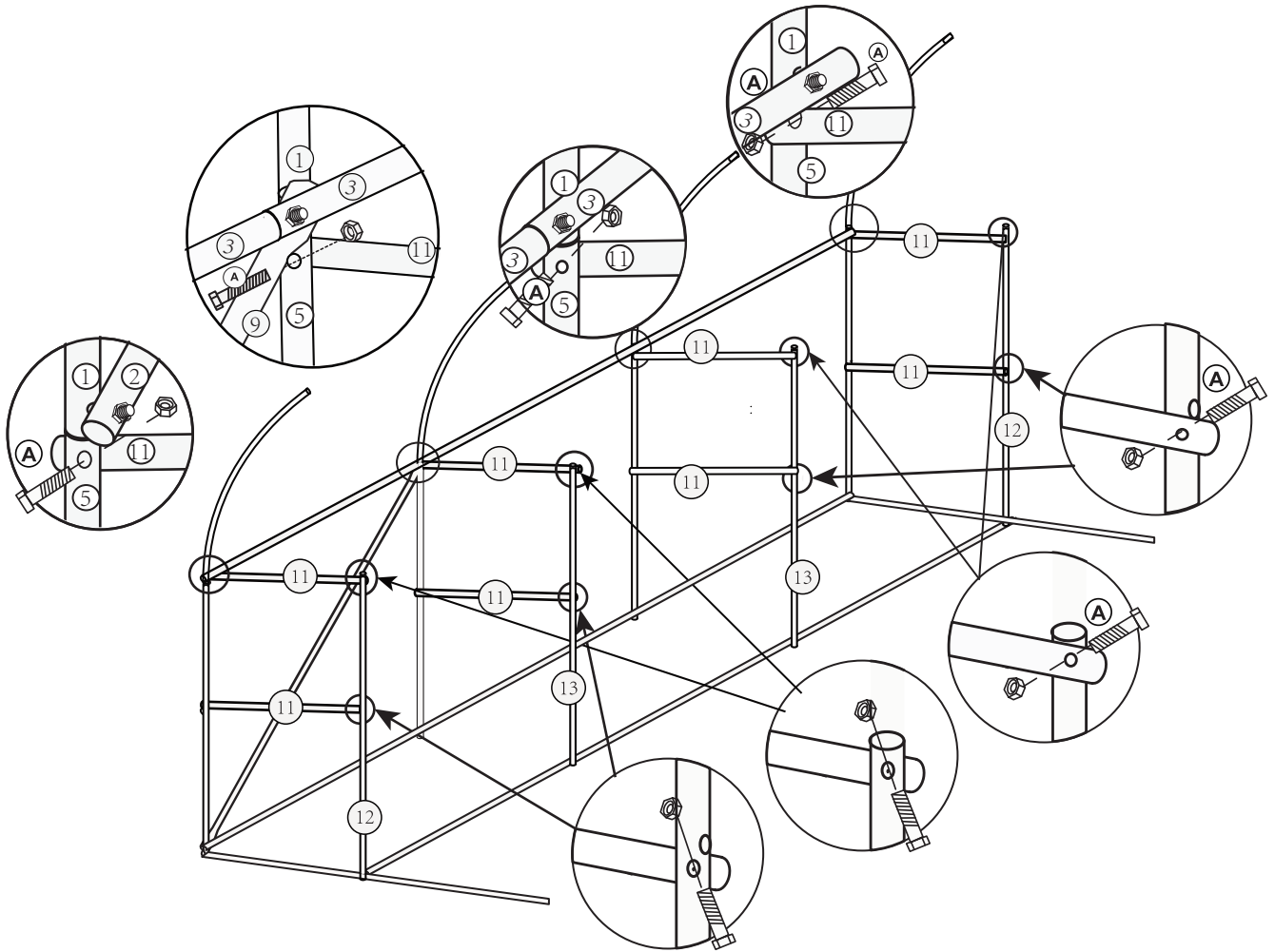

EN_Please pay attention to the position of pipe 11.
 FR_Veuillez prêter attention à la position du tube 11.
 DE_Achten Sie bitte auf die Position von Rohr 11.
 ES_Preste atención a la posición del tubo 11.
 PT_Preste atenção à posição do tubo 11.
 IT_Prestare attenzione alla posizione del tubo 11.
 RO_Vă rugăm să acordați atenție poziției conductei 11.

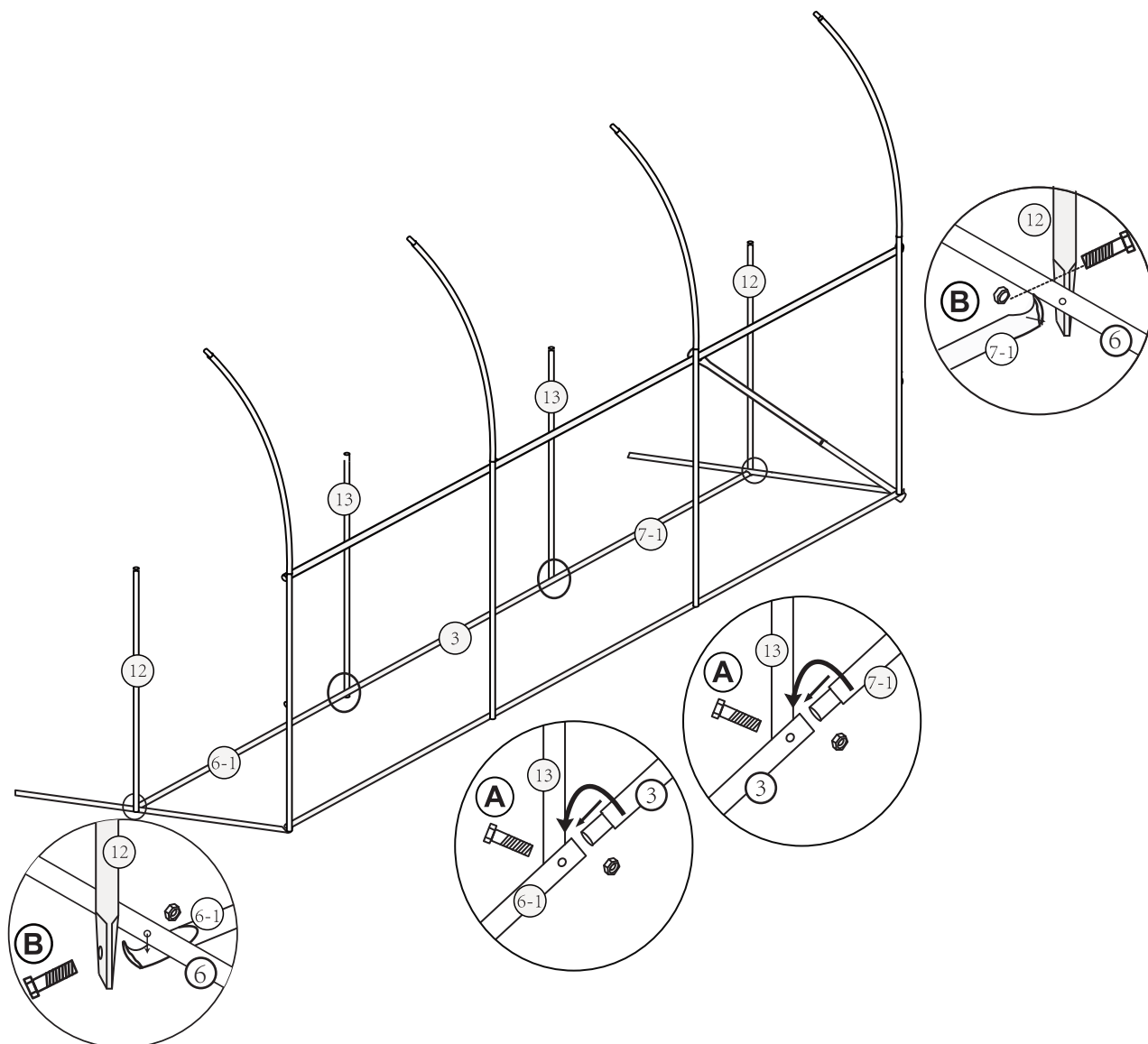

EN_Please pay attention to the position of pipe 11.
 FR_Veuillez prêter attention à la position du tube 11.
 DE_Achten Sie bitte auf die Position von Rohr 11.
 ES_Preste atención a la posición del tubo 11.
 PT_Preste atenção à posição do tubo 11.
 IT_Prestare attenzione alla posizione del tubo 11.
 RO_Vă rugăm să acordați atenție poziției conductei 11.

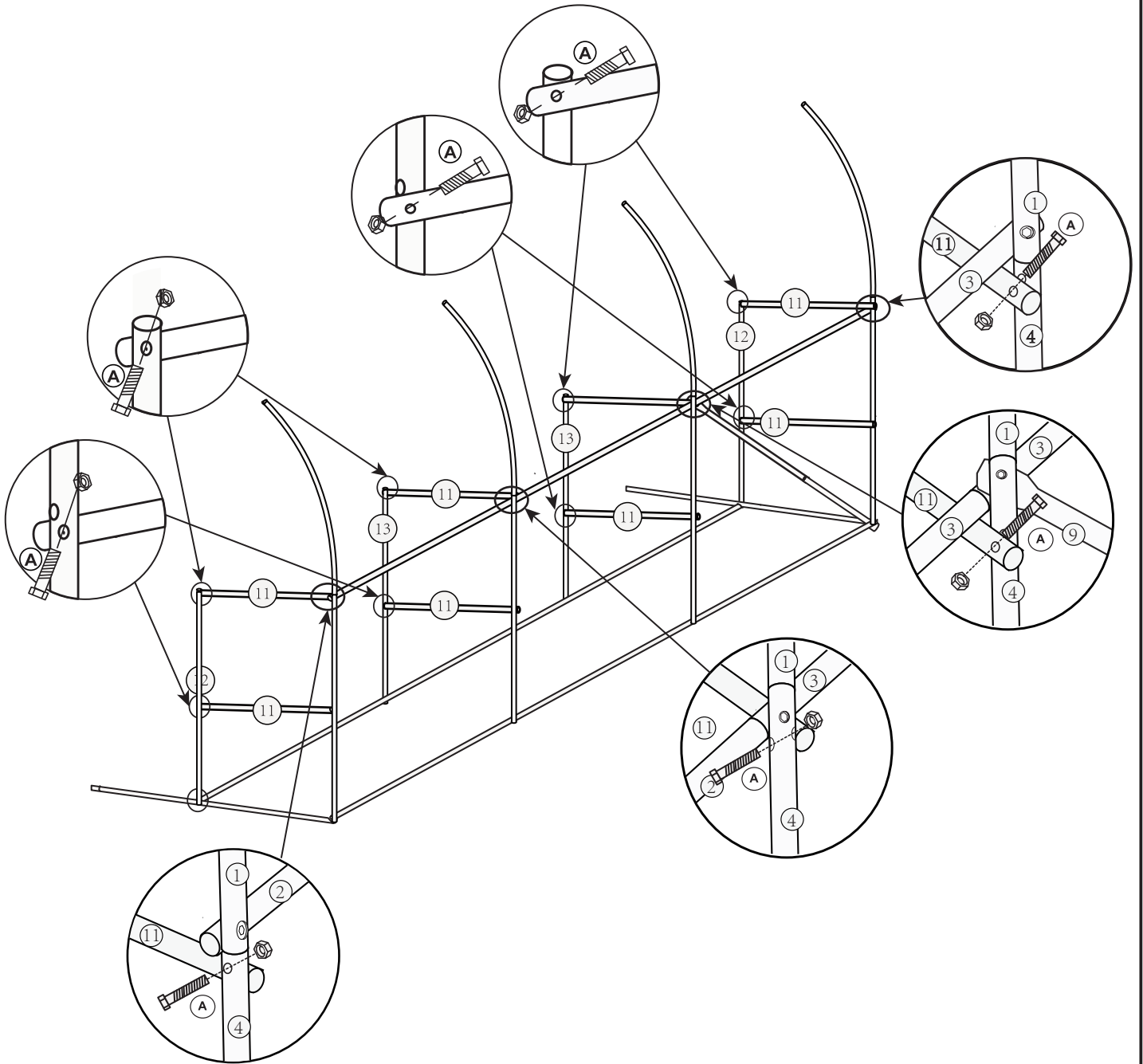

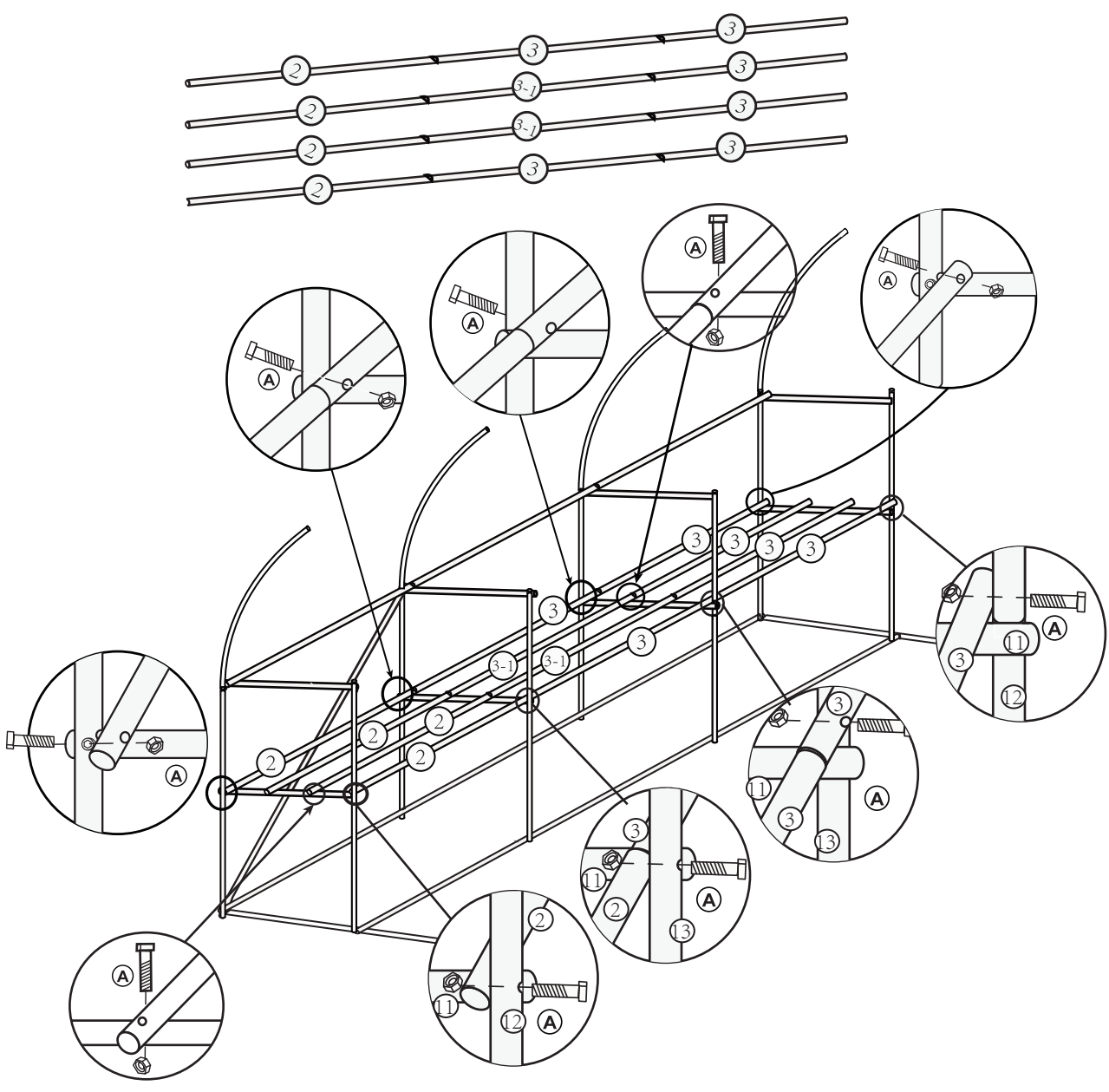

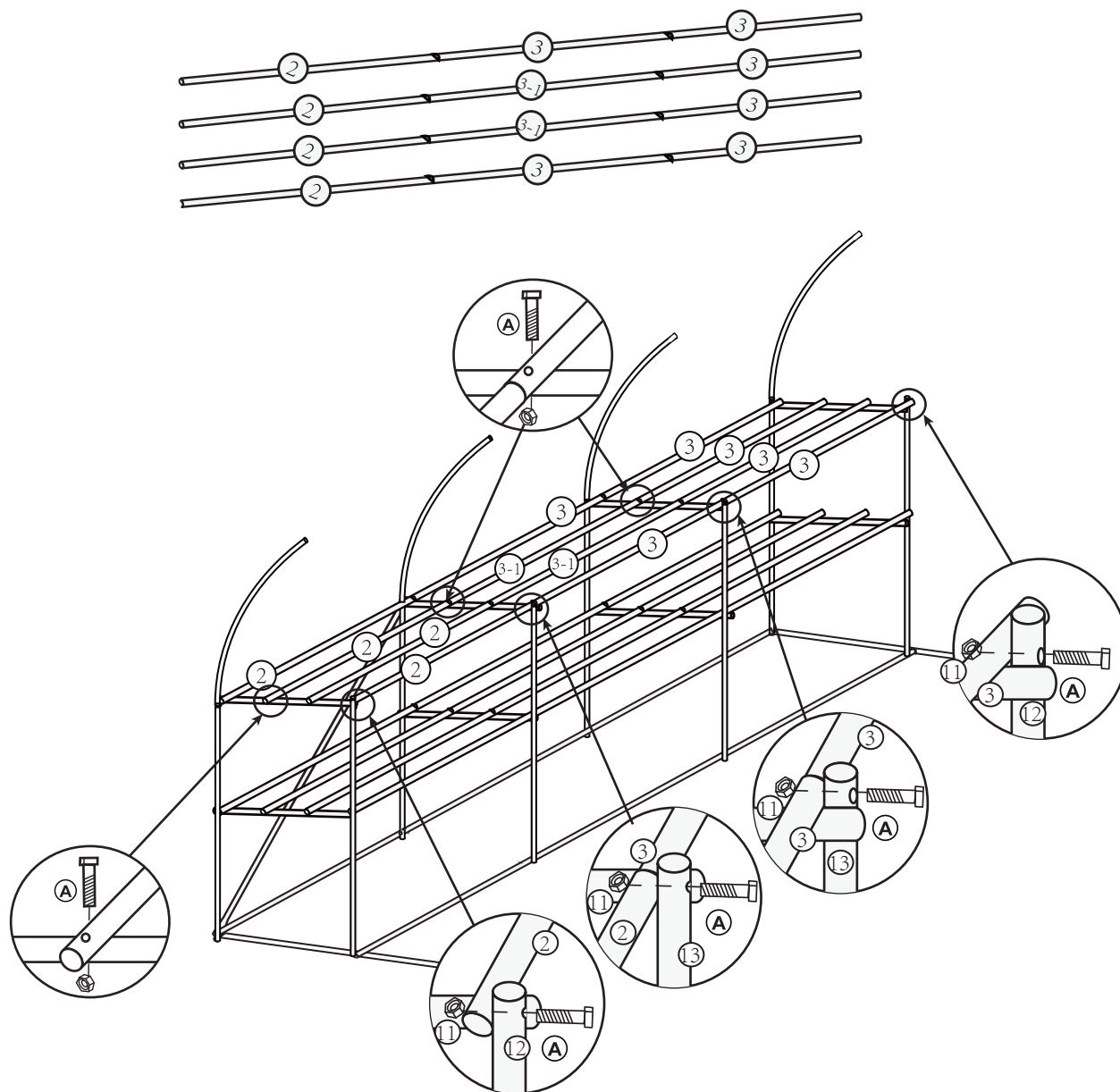

EN_ The installation steps on the right are the same as those on the left.

FR_ Les étapes d'installation indiquées à droite sont identiques à celles de gauche.

DE_ Die Montageschritte auf der rechten Seite entsprechen denen auf der linken Seite.

ES_ Los pasos de instalación de la derecha son los mismos que los de la izquierda.

PT_ Os passos de instalação à direita são os mesmos que os da esquerda.

IT_ I passaggi di installazione riportati a destra sono gli stessi di quelli a sinistra.

RO_ Pașii de instalare din partea dreaptă sunt identici cu cei din partea stângă.

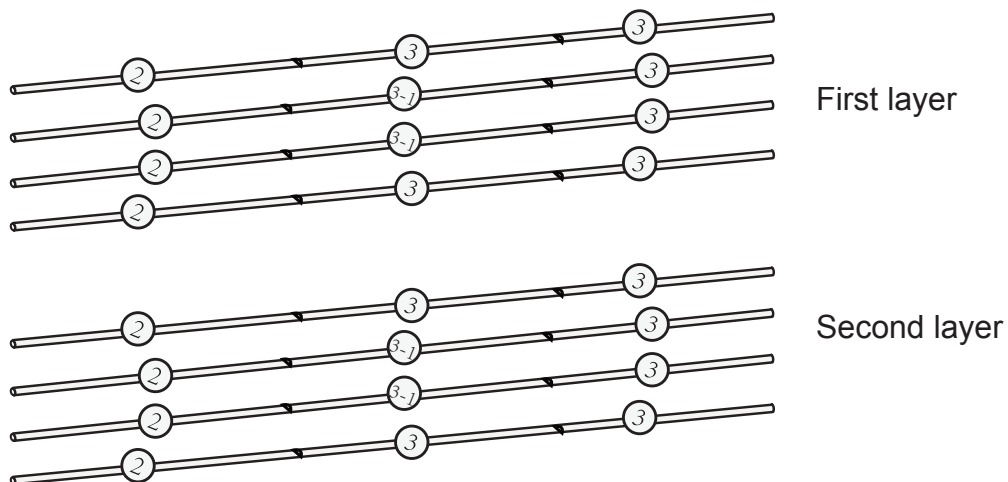

EN_ The four-tier shelf should be assembled as follows

FR_ L'étagère à quatre niveaux doit être assemblée comme suit

ES_ La estantería de cuatro niveles debe montarse de la siguiente manera

PT_ A prateleira de quatro níveis deve ser montada da seguinte forma

DE_ Das vierstufige Regal sollte wie folgt zusammengebaut werden

IT_ Il ripiano a quattro livelli deve essere assemblato come segue

RO_ Raftul cu patru niveluri trebuie asamblat după cum urmează.

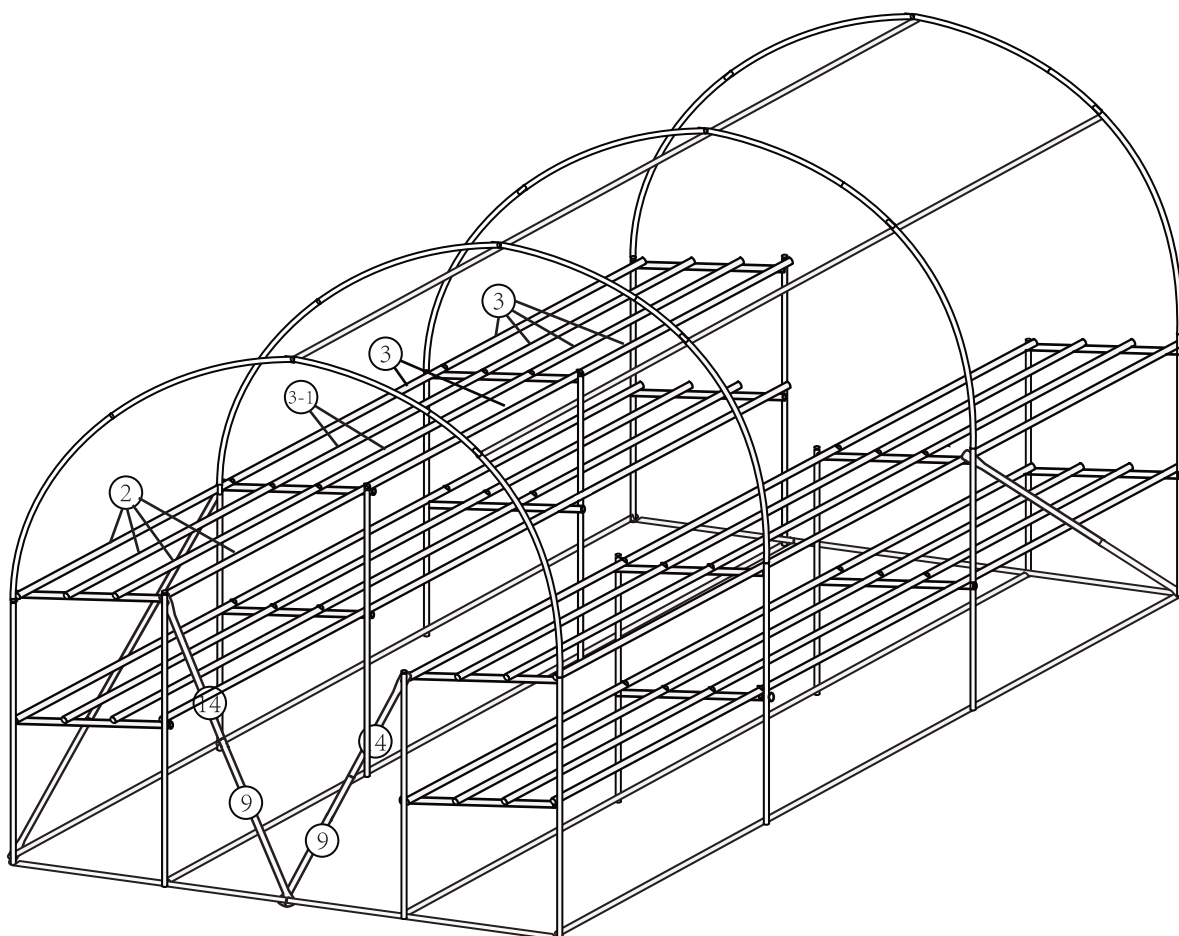

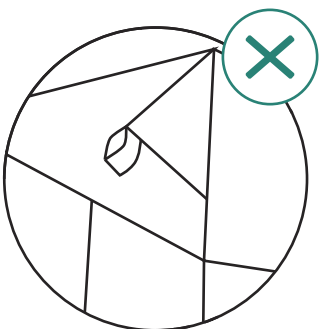
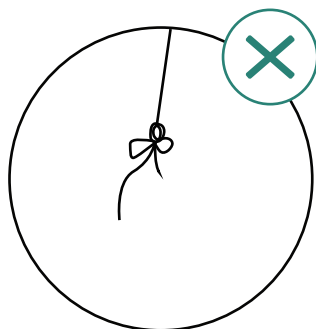
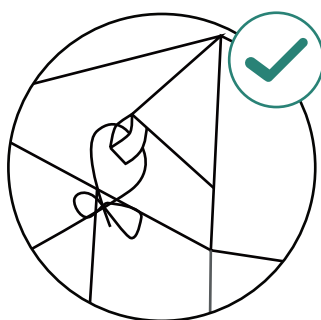
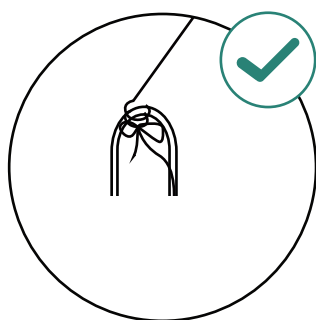
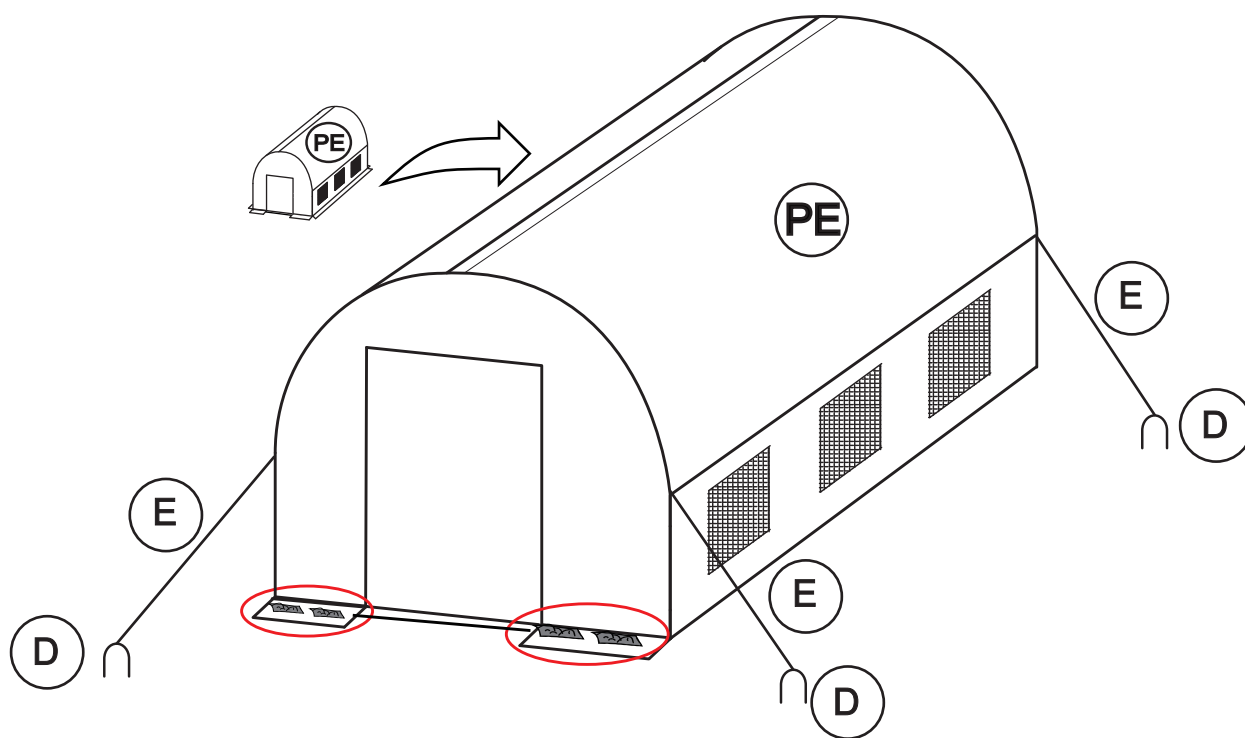

RO Pentru a îmbunătăți rezistența la vânt, asigurați-vă că parcurgeți acest pas de instalare. Dacă nu sunt instalate cuie de fixare în sol, vânturile puternice pot răsturna foisorul.

EN To improve wind resistance be sure to complete this installation step. If ground nails are not installed, strong winds may topple the gazebo.

FR Pour améliorer la résistance au vent, veillez à respecter cette étape d'installation. Si les piquets de fixation au sol ne sont pas installés, des vents violents pourraient renverser le gazebo.

ES Para mejorar la resistencia al viento, asegúrese de completar este paso de la instalación. Si no se instalan clavos de tierra, los vientos fuertes pueden volcar la glorieta.

PT Para melhorar a resistência ao vento, certifique-se de concluir esta etapa da instalação. Se os pregos de fixação ao solo não forem instalados, ventos fortes podem derrubar o gazebo.

DE Um die Windbeständigkeit zu verbessern, führen Sie diesen Installationsschritt unbedingt durch. Wenn keine Erdnägel installiert werden, kann starker Wind den Pavillon umwerfen.

IT Per migliorare la resistenza al vento, assicurarsi di completare questa fase dell'installazione. Se i chiodi di fissaggio al suolo non vengono installati, i venti forti potrebbero ribaltare il gazebo.

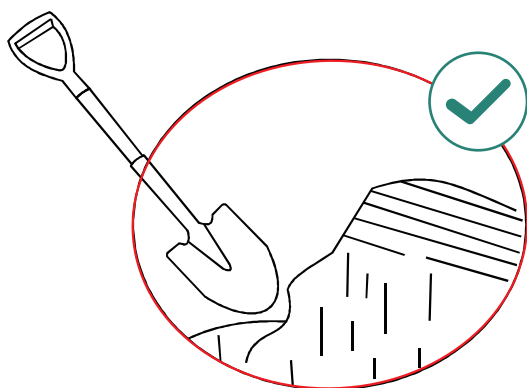
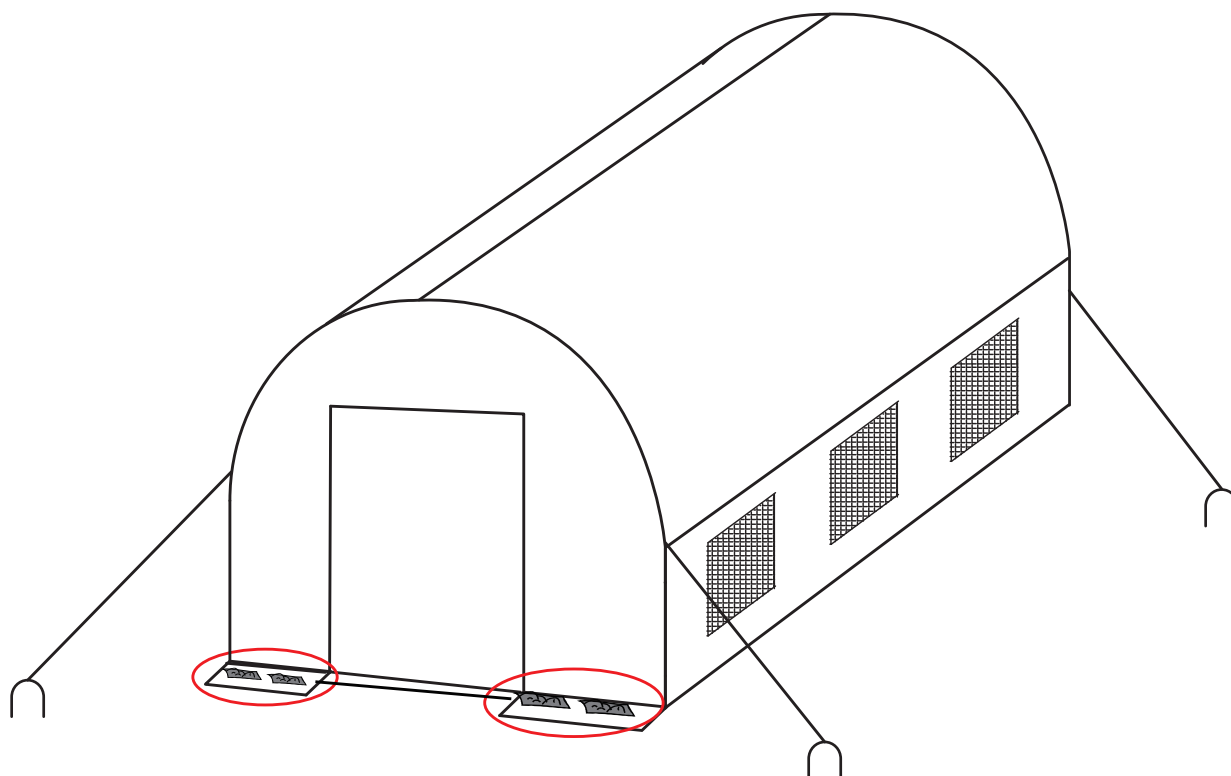

EN Improve greenhouse stability by cementing the peripheral base with soil or small stones.

FR Améliorez la stabilité de la serre en cimentant la base périphérique avec de la terre ou des petits cailloux.

ES Mejora la estabilidad del invernadero cementando la base periférica con tierra o piedras pequeñas.

PT Melhore a estabilidade da estufa cimentando a base periférica com terra ou pequenas pedras.

DE Verbessern Sie die Stabilität des Gewächshauses, indem Sie den Randbereich mit Erde oder kleinen Steinen befestigen.

IT Migliorare la stabilità della serra cementando la base periferica con terra o piccoli sassi.

RO Îmbunătățiți stabilitatea serei prin consolidarea bazei perimetrare cu pământ sau pietricele

If you have any questions, please contact our customer care center, Our contact details are below:

US

 001-877-644-9366

 customerservice@aosom.com

Imported by Aosom LLC
7777 Center Ave. Suite 430
Huntington Beach, CA 92647-9998 USA
MADE IN CHINA

If you have any questions, please contact our customer care center, Our contact details are below:

CA

 416-792-6088

 customerservice@aosom.ca

Imported by Aosom Canada Inc.
7270 Woodbine Avenue, Unit 307, Markham,
Ontario Canada L3R 4B9
MADE IN CHINA

Si vous avez la moindre question, veuillez contacter notre centre d'assistance à la clientèle, Nos coordonnées sont les suivantes:

 416-792-6088

 customerservice@aosom.ca

Importé par Aosom Canada Inc.
7270 Woodbine Avenue, unité 307,
Markham, Ontario Canada L3R 4B9
FABRIQUÉ EN CHINE

Si tiene alguna pregunta, comuníquese con nuestro Centro de Atención al Cliente, Nuestros datos de contacto son los siguientes:

ES

 0034-931294512

 atencioncliente@aosom.es

IMPORTADOR/Fabricante/REP:
SPANISH AOSOM, S.L.
C/ROC GROS, Nº15.08550, ELS HOSTALET DE
BALENYÀ, SPAIN.
B66295775
HECHO EN CHINA

Se tiver alguma dúvida, por favor contacte o nosso Centro de Atendimento ao Cliente, Os nossos dados de contacto são os seguintes:

 0034-931294512

 info@aosom.pt.

Si vous avez la moindre question, veuillez contacter notre centre d'assistance à la clientèle, Nos coordonnées sont les suivantes:

FR

 0033-1-84166106

 aosom@mhfrance.fr

Importé par/Fabricant/REP:
MH FRANCE
2 Rue Maurice Hartmann
92130 Issy Les Moulineaux
France
FABRIQUÉ EN CHINE



FR

**DONNEZ
OU
RECYCLEZ**



ASSOCIATION

OU



LIVRAISON

OU



DÉCHÈTERIE

Adresses sur quefairedemesdechets.fr

If you have any questions, please contact our customer care center, Our contact details are below:

UK

 0044-800-240-4004

 enquiries@mhstar.co.uk

IMPORTER ADDRESS:
MH STAR UK Ltd
1 Northampton Cross Logistics Park
Northampton Cross Road
Northampton
NN4 9FH
MADE IN CHINA

Wenn Sie Fragen haben, wenden Sie sich bitte an unser Kundendienstzentrum, Unsere Kontaktdaten stehen unten:

DE

 0049-0(40)-87408465

 service@aosom.de

ADRESSE DES IMPORTEUR/Hersteller/REP:
MH Handel GmbH
Wendenstraße 309
D-20537 Hamburg
Germany
IN CHINA HERGESTELLT

In caso di dubbio, si prega di contattare il nostro centro assistenza clienti, I nostri dettagli di contatto sono di seguito:

IT

 0039-0249471447

 clienti@aosom.it

IMPORTATO DA/Produttore/REP:
AOSOM Italy srl
Centro Direzionale Milanofiori
Strada 1 Palazzo F1
20057 Assago (MI)
P.I.: 08567220960
FATTO IN CINA

Dacă aveți întrebări, vă rugăm să contactați serviciul nostru clienți. Datele de contact sunt mai jos.

RO

 +40 312294730

 Clienti@aosom.ro

Importator/Producător/REP:
Aosom Romania SRL
Str. Barbu Mumuleanu, nr. 30-32
Bucuresti, Sector 2
FABRICAT IN CHINA