

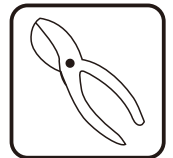

IN251100210V02_GL

84H-664V00

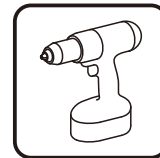
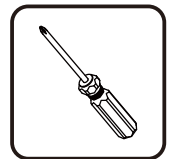
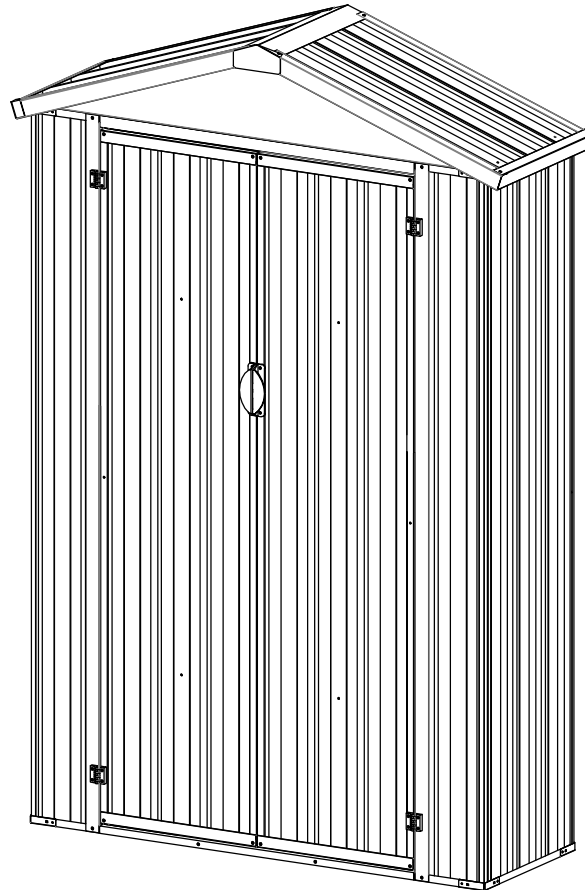

EN Assembly video please scan the QR code.
FR vidéo d'assemblage, veuillez scanner le code QR.
ES Montaje video scannen Sie bitte den QR-Code ein.
PT Video de montagem por favor digitalizar o código QR.
DE Montagevideo: Bitte scannen Sie den QR-Code.
IT Scansionare il codice QR per il Video di Assemblaggio.

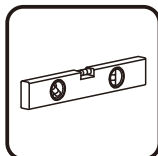
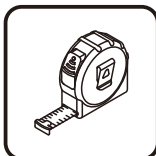
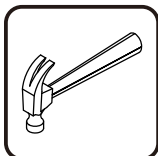
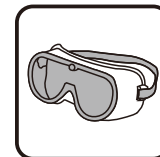
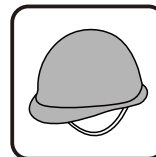

10
STEPS

5 HR



Tools Recommended

EN IMPORTANT, RETAIN FOR FUTURE REFERENCE: READ CAREFULLY.

FR IMPORTANT: A LIRE ATTENTIVEMENT ET À CONSERVER POUR CONSULTATION ULTÉRIEURE.

ES IMPORTANTE, LEA Y GUARDE PARA FUTURAS REFERENCIAS.

PT IMPORTANTE, RETER PARA REFERÊNCIA FUTURA: LEIA ATENTAMENTE.

DE WICHTIG! SORGFÄLTIG LESEN UND FÜR SPÄTER NACHSCHLAGEN AUFBEWAHREN.

IT IMPORTANTE! CONSERVARE IL PRESENTE MANUALE PER FUTURO RIFERIMENTO E LEGGERLO ATTENTAMENTE.

ASSEMBLY PREPARATION

Please check local building codes regarding footings, location and other requirements before beginning construction. Study and understand this owner's manual of important information and helpful tips for easier and more enjoyable assembly.

Assembly instructions:

Reviewing all instructions and the appropriate information before you begin, make sure following the step sequence carefully for successful results.

Flooring base:

The site must be prepared so that the base of the shed is level all round and checking with a spirit level is required.

The base can be constructed by treated timber or concrete, in order to stop the moisture getting into the shed, The shed is not designed to be built onto lawn directly. Also the ground will get muddy during rainy days.

If a concrete pad is made, it is important that this slopes towards the edges to prevent water ingress. Time must be allowed for any concrete or cement to dry before building the shed on top.

Bases can also be constructed from bricks, blocks, or mounted on a concrete pad.

The bricks or blocks should be cemented onto firm and level concrete footings and the greenhouse frame drilled and screwed to the base.

Parts and Parts List:

Before you start, separate and identify all the parts and hardware to be sure that you have all the necessary parts for your building (refer to the Parts List Page).

Do not attempt to assemble the building if parts are missing because any building left partially assembled may be seriously damaged by light winds.

Safety must be put in the No. 1 position:

- 1 Select a dry and calm day for your assembly. Team works (Two or more people) are required during the assembly;
- 2 Wearing safety gloves, eye protection and long sleeves during the assembly to prevent injury; Pay attention to the sharp edge of some parts;
- 3 Children and pets are not allowed entering into the construction site;
- 4 Never concentrate your total weight on the roof of the building. When using a step ladder make sure that it is safety;

Care & Maintenance:

- 1 Keep the shed clean with soft cloth, use water if necessary;
- 2 Keep the door tracks clear of dirt and other stuff that prevent them from sliding easily.
- 3 Clean the snow with necessary tools to make sure it is safe to enter into; Heavy snow may cause collapse, please make sure safety before entering into.
- 4 The shed is not made for living but storing stuff.

PRÉPARATION DE L'ASSEMBLAGE

Veillez vérifier les codes du bâtiment locaux concernant les semelles, l'emplacement et d'autres exigences avant de commencer la construction. Étudiez et comprenez dans ce manuel d'information les informations importantes et les conseils utiles pour un montage plus facile et plus agréable.

Instructions de montage :

Avant de commencer, passez en revue toutes les instructions et les informations appropriées. Assurez-vous de suivre attentivement la séquence des étapes pour obtenir des résultats satisfaisants.

Base de plancher :

Le site doit être préparé de sorte que la base du hangar est de niveau sur le tout pourtour, et il faut vérifier avec un niveau à bulle.

La base peut être construite par du bois traité ou du béton, afin d'empêcher l'humidité de pénétrer dans le hangar. **Le hangar n'est pas conçu pour être construit directement sur la pelouse.** Aussi le sol sera boueux pendant les jours de pluie.

Si un tampon en béton est fait, il est important que celle-ci soit inclinée vers les bords pour empêcher l'eau de pénétrer.

Le temps doit être autorisé pour tout béton ou ciment à sécher avant de construire le hangar sur le dessus.

La base peut également être construite à partir de briques, de blocs ou montées sur un socle en béton.

Les briques ou les blocs doivent être cimentés sur des semelles en béton fermes et de niveau et le cadre de serre drillé et vissé à la base.

Pièces et liste des pièces :

Avant de commencer, séparez et identifiez toutes les pièces et le matériel pour vous assurer que vous avez toutes les pièces nécessaires pour votre bâtiment (voir la page Liste des pièces).

N'essayez pas d'assembler le bâtiment si des pièces manquent, car tout bâtiment laissé partiellement assemblé peut être gravement endommagé par de légers vents.

La sécurité doit être votre préoccupation no.1 :

1. Sélectionnez un jour sec et calme pour votre assemblée. Le travail en équipe (deux personnes ou plus) est requis pendant le montage.

2. Porter des gants de protection, des lunettes de protection et des manches longues pendant le montage pour éviter les blessures ; Faites attention au bord tranchant de certaines parties ;

3. Les enfants et les animaux domestiques ne sont pas admis sur le chantier de construction.

4. Ne concentrez jamais votre poids total sur le toit du bâtiment. Lorsque vous utilisez un escabeau, assurez-vous qu'il est en sécurité.

Entretien et maintenance :

1. Gardez la remise propre avec un chiffon doux, utilisez de l'eau si nécessaire ;

2. Gardez les rails de la porte exempts de saleté et autres objets qui les empêchent de glisser facilement.

3. Nettoyer la neige avec les outils nécessaires pour s'assurer qu'il est sans danger d'entrer ; Une neige abondante peut provoquer un effondrement, assurez-vous de la sécurité avant d'entrer.

4. La remise n'est pas faite pour soulever mais pour ranger des objets.

PREPARACIÓN DEL MONTAJE

Antes de comenzar la construcción, consulte los códigos de construcción locales con respecto a las bases, la ubicación y otros requisitos. Estudie y comprenda este manual del propietario ya que contiene información importante y consejos útiles para un montaje más fácil y agradable.

Instrucciones de montaje

Revise todas las instrucciones y la información apropiada antes de comenzar, asegúrese de seguir cuidadosamente la secuencia de pasos para obtener resultados exitosos.

Base de suelo:

El sitio para realizar la instalación debe estar preparado para que la base del cobertizo esté nivelada y se requiera verificar con un nivel de burbuja.

Para evitar que la humedad penetre en el cobertizo, la base se puede construir con madera tratada u hormigón. **El cobertizo no está diseñado para ser construido directamente sobre el césped.** Además, el suelo se enlodará durante los días lluviosos.

Si hace una plataforma de hormigón, es importante que las pendientes inclinen hacia los bordes para evitar la entrada de agua.

Debe esperar para que la plataforma de hormigón, concreto o cemento se seque antes de construir el cobertizo en sobre la plataforma.

Las bases también pueden ser construidas con ladrillos, bloques o montarse sobre una plataforma de hormigón.

Los ladrillos o bloques deben ser cementados sobre las bases de concreto firmes y niveladas y el marco del invernadero debe ser perforado y atornillado a la base.

Lista de Piezas y Accesorios:

Antes de comenzar, separe e identifique todas las piezas y el hardware para asegurarse de que tiene todas las piezas necesarias para su cobertizo (consulte la página de Lista de Piezas).

No intente ensamblar el cobertizo si faltan piezas, porque cualquier cobertizo parcialmente ensamblado puede resultar seriamente dañado por vientos ligeros.

La seguridad se debe enfocar en la posición No. 1.

- 1 Seleccione un día seco y tranquilo para su montaje. Se requiere trabajo en equipo (dos o más personas) durante el montaje.
- 2 Use guantes de seguridad, protección ocular y mangas largas durante el montaje para evitar lesiones; Preste atención al borde afilado de algunas partes.
- 3 Los niños y las mascotas no pueden ingresar al sitio de construcción.
- 4 Nunca concentre su peso total en el techo del edificio. Cuando utilice una escalera de mano, asegúrese de que sea segura.

Cuidado y Mantenimiento

- 1 Mantenga limpio el cobertizo con un paño suave, use agua si es necesario.
- 2 Mantenga los rieles de las puertas libres de suciedad y otras cosas que eviten que se deslicen fácilmente.
- 3 Limpie la nieve con las herramientas necesarias para asegurarse de que sea seguro ingresar; Las fuertes nevadas pueden provocar un colapso, por favor asegúrese de seguridad antes de entrar.
- 4 El cobertizo no está hecho para vivir sino para almacenar cosas.

PREPARAÇÃO DA MONTAGEM

favor, verifique os regulamentos locais de construção no que diz respeito a pavimentos, localização e outros requisitos antes de iniciar a construção. Leia e compreenda este manual do proprietário com informações importantes e dicas úteis para uma montagem mais fácil e mais prazerosa.

Instruções de montagem:

Rever todas as instruções e a informação apropriada antes de começar, certificar-se de seguir cuidadosamente a sequência de passos para obter resultados bem sucedidos.

Base de pavimento:

O local deve ser preparado de modo a que a base do galpão esteja nivelada em toda a volta e é necessário verificar com um nível de espírito.

A base pode ser construída com madeira tratada ou betão, a fim de impedir que a humidade entre no barracão, O barracão não foi concebido para ser construído directamente sobre a relva, e o solo também ficará lamacento durante os dias de chuva.

Se for feita uma almofada de betão, é importante que este desnível se incline para as margens para evitar a entrada de água, deve ser dado tempo para que qualquer betão ou cimento seque antes de construir o barracão no topo.

As bases também podem ser construídas a partir de tijolos, blocos, ou montadas sobre uma almofada de betão.

Os tijolos ou blocos devem ser cimentados em sapatas de betão firmes e niveladas e a armação da estufa deve ser perfurada e aparafusada à base.

Lista de peças:

Antes de começar, separe e identifique todas as peças e equipamentos para ter a certeza de que tem todas as peças necessárias para o seu abrigo (consulte a página Lista de Peças).

Não tente montar o abrigo se faltarem peças porque qualquer abrigo deixado parcialmente montado pode ser seriamente danificado por ventos fracos.

A segurança deve ser colocada na posição nº 1:

- 1 Seleccione um dia seco e calmo para a sua montagem. Trabalhos de equipa (duas ou mais pessoas) são necessários durante a montagem;
- 2 Usar luvas de segurança, protecção dos olhos e mangas compridas durante a montagem para evitar ferimentos; Prestar atenção à aresta afiada de algumas peças;
- 3 Não é permitida a entrada de crianças e animais de estimação no abrigo durante a construção;
- 4 Nunca concentre o seu peso total no telhado do edifício. Ao utilizar uma escada de mão, certifique-se de que é segura;

Cuidados e Manutenção:

- 1 Mantenha o abrigo limpo com um pano macio, use água se necessário;
- 2 Mantenha os caminhos das portas livres de sujidade e outras coisas que os impeçam de deslizar facilmente.
- 3 Limpar a neve com as ferramentas necessárias para garantir que é seguro entrar; A neve pesada pode causar desmoronamento, por favor, garantir a segurança antes de entrar.
- 4 O abrigo não é feito para viver, mas para armazenar coisas.

VORBEREITUNG FÜR DIE MONTAGE

Vor Beginn der Bauarbeiten überprüfen Sie bitte die örtlichen Bauvorschriften in Bezug auf Fußböden, Standort und andere Anforderungen. Lesen und verstehen Sie diese Bedienungsanleitung mit wichtigen Informationen und hilfreichen Tipps für eine einfachere und angenehmere Montage.

Montageanweisung:

Überprüfen Sie alle Anweisungen und die entsprechenden Informationen, bevor Sie beginnen. Stellen Sie bitte sicher, dass Sie die Schrittsequenz sorgfältig befolgen, um erfolgreiche Ergebnisse zu erzielen.

Bodenbelag:

Der Standort muss so vorbereitet werden, dass der Boden des Schuppens rundum eben ist, und eine Überprüfung mit einer Wasserwaage ist erforderlich.

Der Sockel kann aus behandeltem Holz oder Beton hergestellt werden, um das Eindringen von Feuchtigkeit in den Schuppen zu verhindern. Der Schuppen ist nicht dafür vorgesehen, direkt auf Rasenflächen gebaut zu werden. Auch der Boden wird an Regentagen matschig.

Wenn eine Betonplatte hergestellt wird, ist es wichtig, dass diese zu den Rändern hin geneigt ist, um das Eindringen von Wasser zu verhindern.

Vor dem Bau des Schuppens muss Zeit zum Trocknen von Beton oder Zement eingeplant werden.

Die Fundamente können auch aus Ziegelsteinen oder Blöcken gebaut oder auf eine Betonplatte montiert werden.

Die Ziegel oder Blöcke sollten auf feste und ebene Betonfundamente zementiert und der Gewächshausrahmen gebohrt und mit dem Sockel verschraubt werden.

Teile und Teileliste:

Bevor Sie beginnen, trennen und identifizieren Sie alle Teile und Hardware, um sicherzustellen, dass Sie alle erforderlichen Teile für Ihr Gebäude haben (siehe Seite Teileliste).

Versuchen Sie nicht, das Gebäude zusammenzubauen, wenn Teile fehlen, da ein teilweise zusammengebautes Gebäude durch leichten Wind ernsthaft beschädigt werden kann.

Achten Sie erst auf die Sicherheit :

1 Wählen Sie einen trockenen und ruhigen Tag für Ihre Montage aus. Teamarbeiten (Zwei oder mehr Personen) sind während der Montage erforderlich;

2 Tragen Sie die Schutzhandschuhen, Augenschutz und langen Ärmeln bei der Montage zur Vermeidung von Verletzungen; Achten Sie auf die scharfe Kante für einige Teile;

3 Die Kinder und Haustiere dürfen nicht auf die Baustelle betreten;

4 Konzentrieren Sie niemals Ihr Gesamtgewicht auf das Dach des Gebäudes. Bei Verwendung einer Trittleiter sollen Sie die Sicherheit gewährleisten.

Pflege und Wartung:

1 Halten Sie den Schuppen mit einem weichen Tuch sauber, verwenden Sie das Wasser wenn nötig;

2 Halten Sie die Türschiene von Schmutz und anderen Gegenständen fern, damit sie nicht leicht verrutschen können.

3 Reinigen Sie den Schnee mit den notwendigen Werkzeugen, um sicherzugehen, dass Sie sicher betreten können; Starker Schneefall kann zum Einsturz führen, bitte gewährleisten Sie die Sicherheit vor dem Betreten .

4 Der Schuppen ist nicht zum Wohnen gemacht, sondern zum Aufbewahren von Sachen.

MONTAGGIO

Prima di iniziare, si prega di verificare i regolamenti edilizi locali relativi alle fondamenta, alla posizione e ad altri requisiti. Si prega di studiare e comprendere questo manuale di informazioni importanti e suggerimenti utili per un assemblaggio più semplice.

Istruzioni di assemblaggio:

Si prega di visionare tutte le istruzioni e le informazioni prima di iniziare, accertandosi di seguire attentamente la sequenza di passaggi.

Fondazione del pavimento:

L'area deve essere preparata in modo che la base del capannone sia livellata tutt'intorno ed è necessario verificare con una livella a bolla d'aria.

Le fondamenta possono essere costruite in legno trattato o cemento, per impedire che l'umidità penetri nel capannone. **Il capannone non è progettato per essere costruito direttamente sul prato.** Il terreno diventerà fangoso durante i giorni di pioggia.

Se viene posizionato su un blocco di cemento, è importante che esso sia inclinato ai bordi per evitare l'ingresso di acqua.

È necessario attendere che il calcestruzzo o il cemento si asciughino prima di costruirvi sopra il capannone.

Le fondamenta possono anche essere costruite da mattoni, blocchi o direttamente da un blocco di cemento.

I mattoni devono essere cementati su basi di cemento solide e livellate in piano, e il telaio del capannone va forato e avvitato alla base.

Parti e lista delle parti:

Prima di iniziare, separare e identificare tutte le parti e l'hardware per essere sicuri di disporre di tutte le parti necessarie per la costruzione (fare riferimento alla pagina della Lista delle Parti).

Non tentare di montare la costruzione se mancano parti perché qualsiasi costruzione lasciata parzialmente assemblata può essere seriamente danneggiata da venti leggeri.

La sicurezza deve venire prima di tutto:

- 1 Scegli un giorno asciutto e calmo per il tuo assemblaggio. Il lavoro di gruppo (due o più persone) è richiesto durante l'assemblaggio;
- 2 Indossare guanti di sicurezza, occhiali protettivi e maniche lunghe durante l'assemblaggio per evitare lesioni. Prestare attenzione al bordo tagliente di alcune parti;
- 3 Ai bambini e agli animali domestici non è consentito entrare nel cantiere;
- 4 Non concentrare mai il peso totale sul tetto dell'edificio. Quando si utilizza una scala a pioli, assicurarsi che sia sicura;

Manutenzione:

- 1 Tenere il capanno pulito con un panno morbido, usare acqua se necessario;
- 2 Tenere i binari della porta liberi da sporcizia e altre cose che impediscano loro di scivolare facilmente.
- 3 Pulisci la neve con gli strumenti necessari per assicurarti che sia sicuro entrare; La neve pesante può causare il collasso, controlla che sia sicuro prima di entrare.
- 4 Il capanno non è ideato come zona abitativa, ma solo come magazzino.

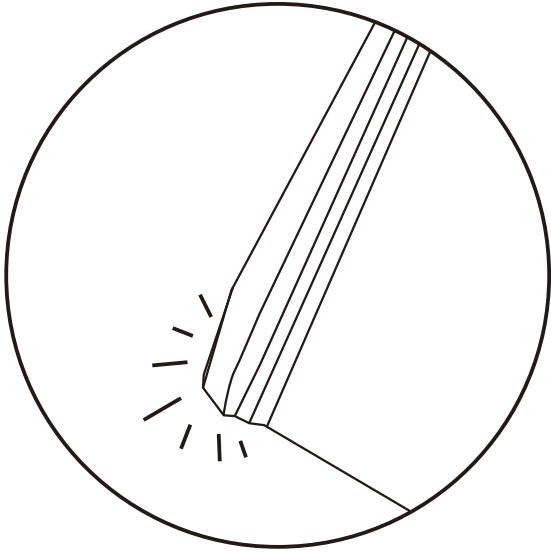

EN_NOTICE: If there is slight bending on the corners

FR_AVIS : En cas de légère courbure des angles

ES_NOTA: Si hay una ligera flexión en las esquinas

PT_AVISO: Se houver uma ligeira dobragem nas esquinas

DE_HINWEIS: Wenn die Ecken leicht gebogen sind

IT_AVVISO: Qualora ci fosse una leggera flessione sugli angoli

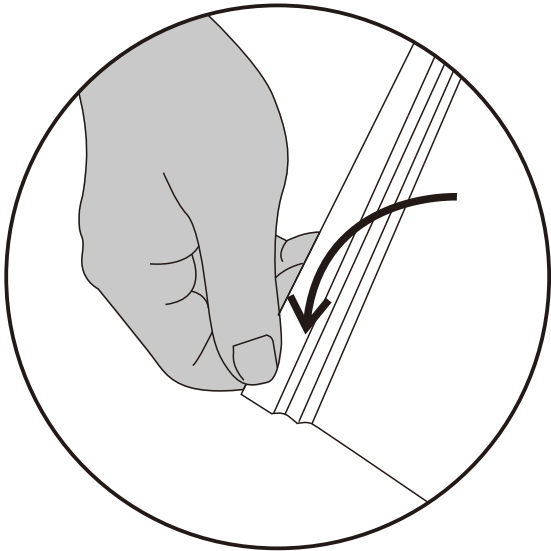

EN_1. Pls wear gloves and stretch the corners slightly until they are flat

FR_1. Veuillez porter des gants et exercer une légère torsion sur les bords jusqu'à ce qu'ils soient plats

ES_1. Por favor, use guantes y estire las esquinas ligeramente hasta que queden planas

PT_1. Utilize uma luva e estique ligeiramente os cantos até que estejam normais

DE_1. Bitte tragen Sie Handschuhe und dehnen Sie die Ecken leicht, bis sie flach sind

IT_1. Si prega di indossare dei guanti e di allungare leggermente gli angoli fino a quando non si sono appiattiti

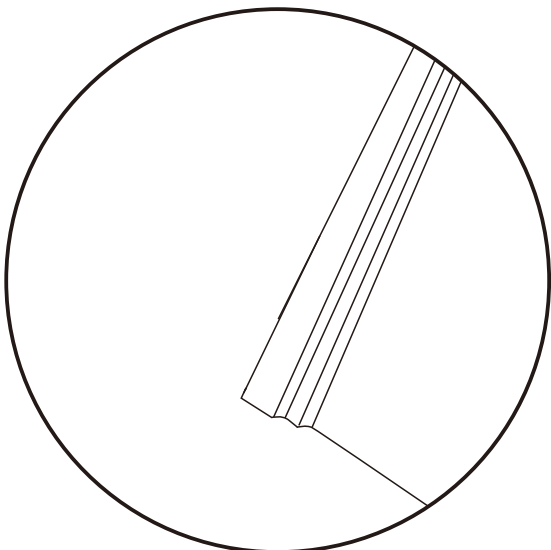

EN_2. Then the sheets will be normal and there is no effect on the assembling

FR_2. Les feuilles deviennent alors normales ; sans incidence sur l'assemblage.

ES_2. Entonces las hojas serán normales y no hay ninguna influencia sobre el ensamblaje

PT_2. Em seguida, os painéis estarão normais e não há efeito sobre a montagem

DE_2. Dann sind die Platten normal und es gibt keine Auswirkungen auf den Zusammenbau

IT_2. Quindi le lastre torneranno normali e non vi sarà alcun effetto sull'assemblaggio

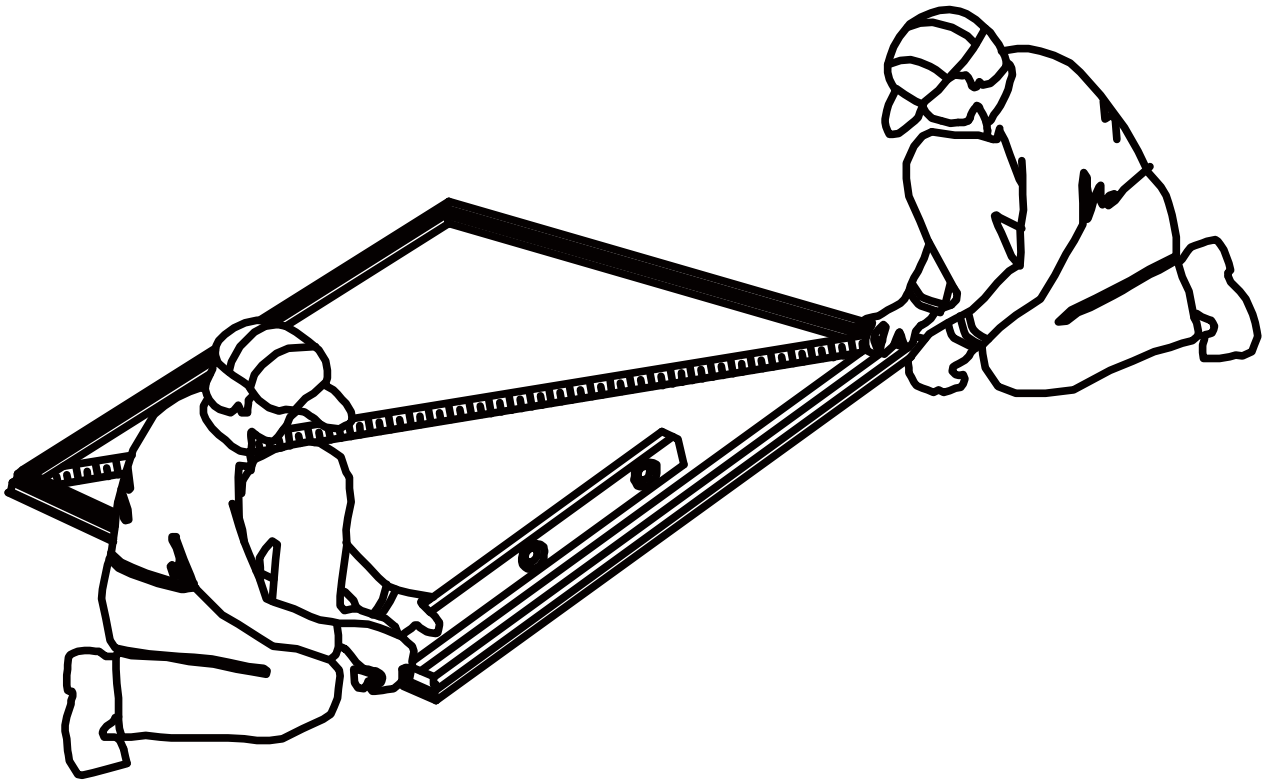

EN:

1. When diagonal measurements are equal, the frame is square.
2. The Floor Frame must be BOTH square AND level or the holes will not line up properly.

FR:

1. lorsque les mesures diagonales sont égales, le cadre est carré.
2. le cadre de plancher doit être à la fois carré ET de niveau ou les trous ne s'aligneront pas correctement.

ES:

1. Cuando las medidas diagonales son iguales, el marco es cuadrado.
2. El marco del piso debe estar TANTO a escuadra como nivelado o los orificios no se alinearán correctamente.

PT:

1. quando as medidas diagonais são iguais, a moldura é quadrada.
2. a moldura do chão deve ser AMBOSA quadrada E nivelada ou os buracos não se alinharão correctamente.

DE:

1. Wenn die diagonalen Maße gleich sind, ist der Rahmen quadratisch.
2. Der Bodenrahmen muss sowohl quadratisch als auch eben sein, da sonst die Löcher nicht richtig ausgerichtet sind.

IT:

1. Quando le misure diagonali sono uguali, la cornice è quadrata.
2. Il telaio del pavimento deve essere SIA quadrato CHE a livello o i fori non si allineeranno correttamente.

EN_ BEFORE YOU START -HOW PANELS ARE JOINED.

FR_ AVANT DE COMMENCER - COMMENT ASSEMBLER LES PANNEAUX.

DE_ VOR DEM START – WIE DIE PLATTEN VERBUNDEN WERDEN.

ES_ ANTES DE EMPEZAR: CÓMO SE UNEN LOS PANELES.

PT_ ANTES DE COMEÇAR - COMO OS PAINÉIS SÃO UNIDOS.

IT_ PRIMA DI INIZIARE - COME SI UNISCONO I PANNELLI.

EN_ Position U channel over one end of the joined sheets, working from one end push channel down to clip onto sheets, continue to the end of the channel pushing as you go.

FR_ Placez le profilé en U sur une extrémité des feuilles assemblées, en commençant par une extrémité, enfoncez le profilé pour le clipser sur les feuilles, puis continuez jusqu'à l'autre extrémité du profilé en poussant au fur et à mesure.

DE_ Positionieren Sie den U-Kanal über einem Ende der verbundenen Bleche, drücken Sie den Kanal von einem Ende aus nach unten, um ihn an den Blechen zu befestigen, und fahren Sie bis zum Ende des Kanals fort, wobei Sie ihn dabei nach unten drücken.

ES_ Coloque el canal en U sobre un extremo de las láminas unidas, trabajando desde un extremo, empuje el canal hacia abajo para fijarlo a las láminas y continúe hasta el final del canal empujando a medida que avanza.

PT_ Posicione o canal em U sobre uma das extremidades das folhas unidas, trabalhando a partir de uma extremidade, empurre o canal para baixo para prendê-lo nas folhas e continue até ao fim do canal, empurrando à medida que avança.

IT_ Posizionare il canale a U su un'estremità dei fogli uniti, lavorando da un'estremità spingere il canale verso il basso per agganciarlo ai fogli, continuare fino alla fine del canale spingendo man mano che si procede.

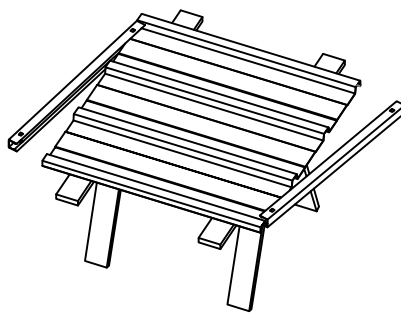

EN_ A raised platform will make assembly easier.

FR_ Une plate-forme surélevée facilitera le montage.

DE_ Eine erhöhte Plattform erleichtert die Montage.

ES_ Una plataforma elevada facilitará el montaje.

PT_ Uma plataforma elevada facilitará a montagem.

IT_ Una piattaforma rialzata faciliterà il montaggio.

EN_ If you need to remove U channels from the panels, pull the channel along the panel from opposing ends. You may need someone to help with this.

FR_ Si vous devez retirer les profilés en U des panneaux, tirez le profilé le long du panneau à partir des extrémités opposées. Vous aurez peut-être besoin de l'aide d'une autre personne pour cette opération.

DE_ Wenn Sie U-Kanäle von den Platten entfernen müssen, ziehen Sie den Kanal entlang der Platte von gegenüberliegenden Enden. Möglicherweise benötigen Sie dabei Hilfe.

ES_ Si necesita retirar los canales en U de los paneles, tire del canal a lo largo del panel desde los extremos opuestos. Es posible que necesite ayuda para ello.

PT_ Se precisar remover os canais em U dos painéis, puxe o canal ao longo do painel a partir das extremidades opostas. Pode ser necessário pedir ajuda a alguém para fazer isso.

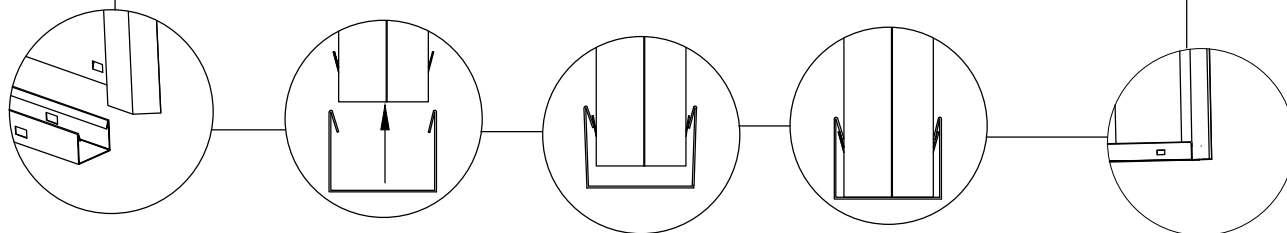
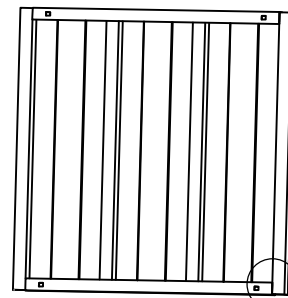
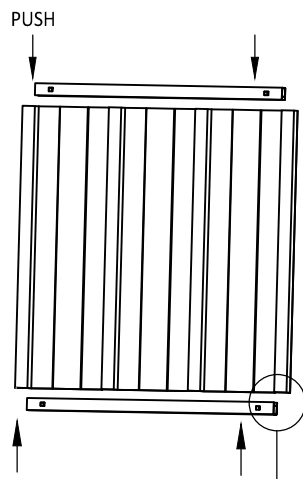

IT_ Se è necessario rimuovere i canali a U dai pannelli, tirare il canale lungo il pannello dalle estremità opposte. Potrebbe essere necessario l'aiuto di qualcuno.



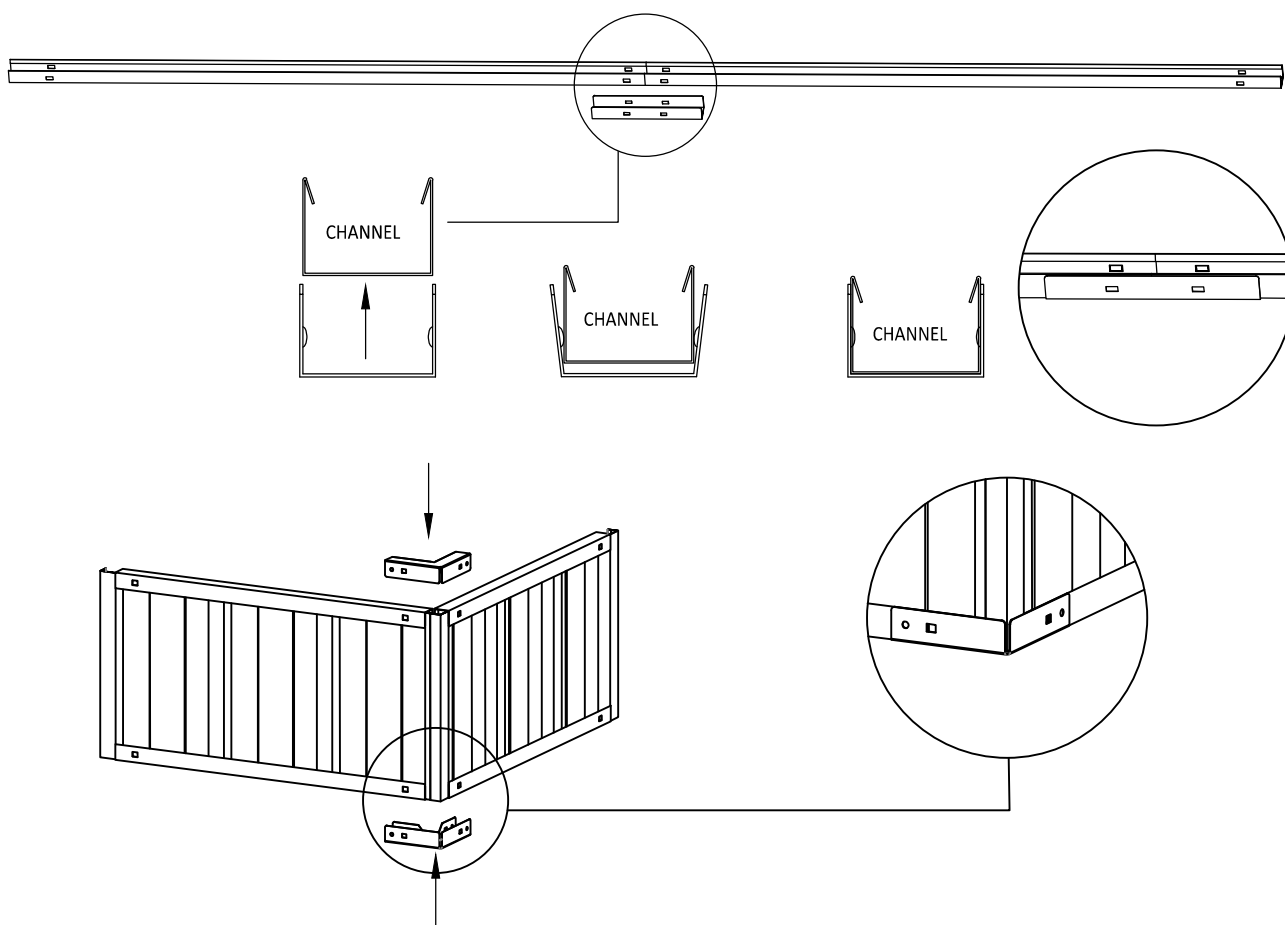

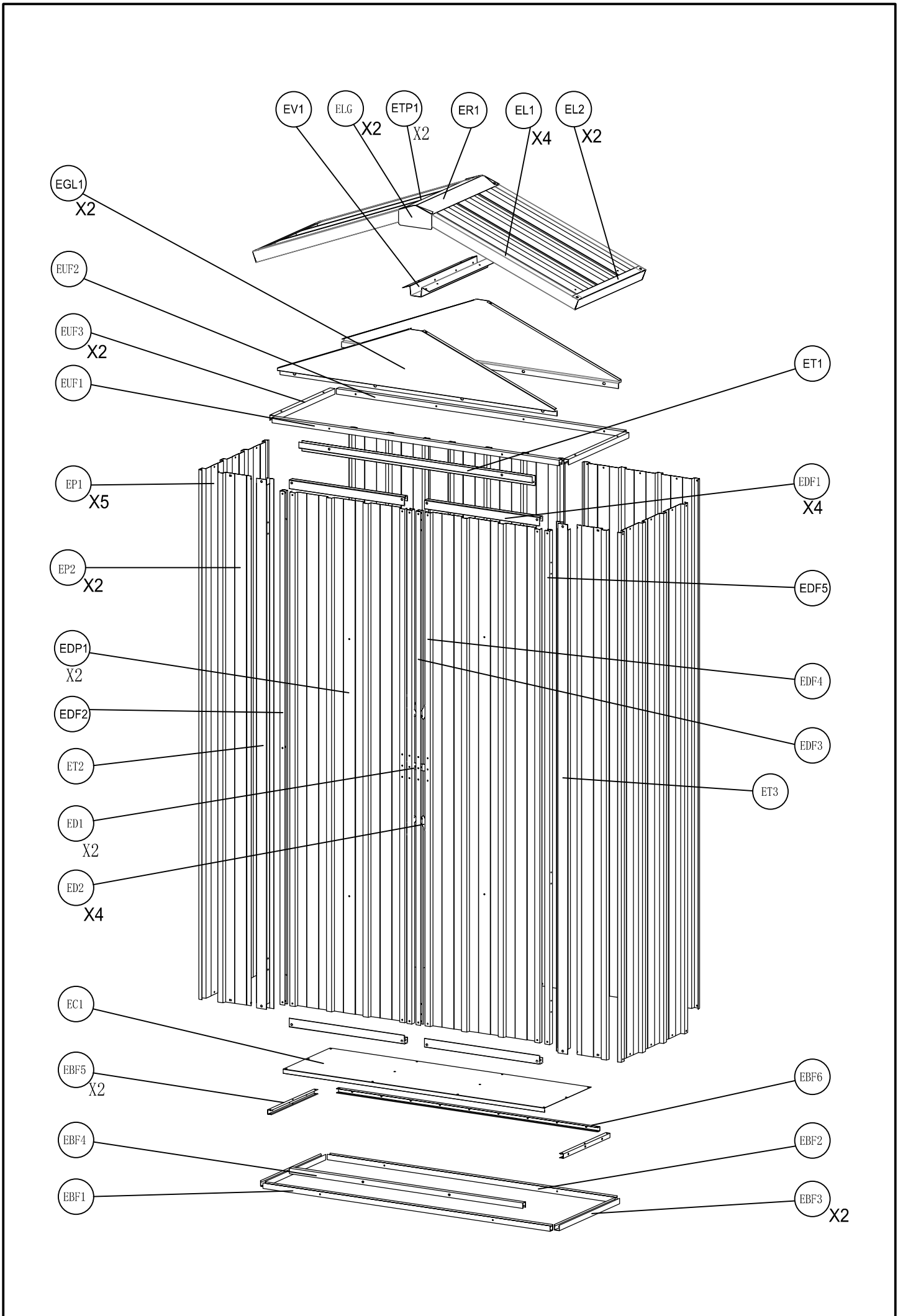

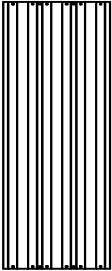

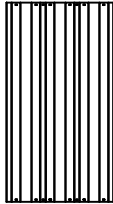
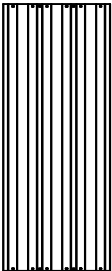
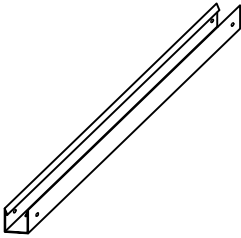
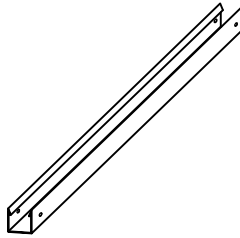
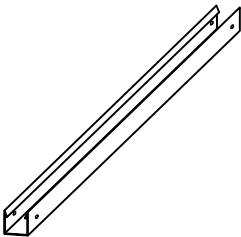
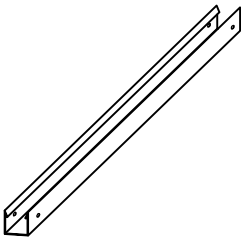
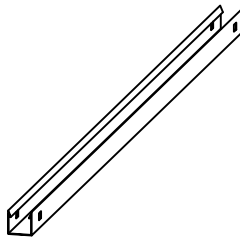
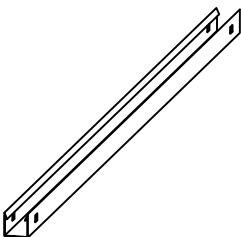
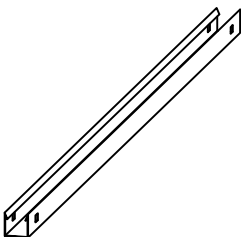
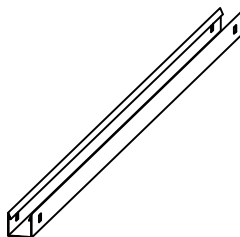
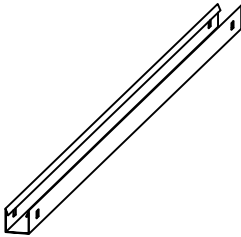
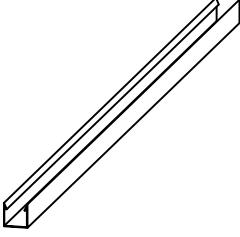
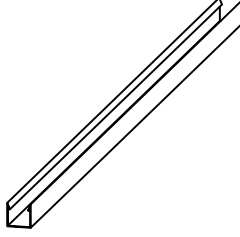

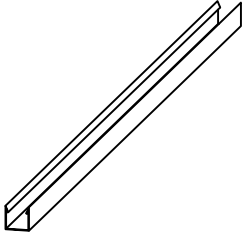
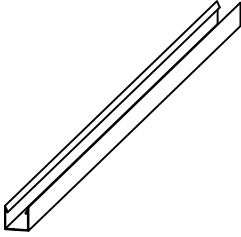
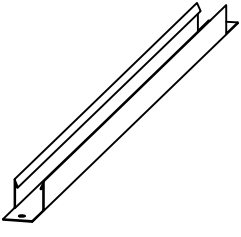
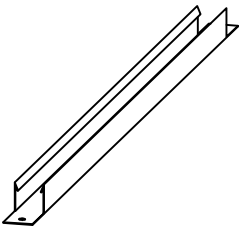
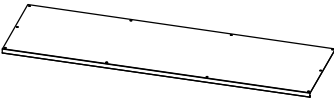
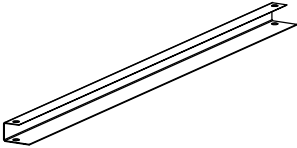
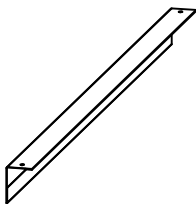
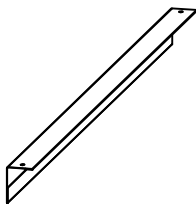
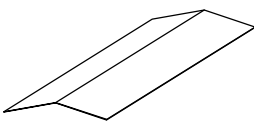
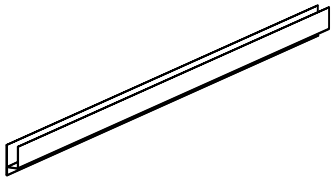
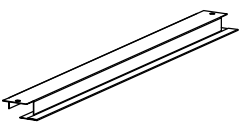
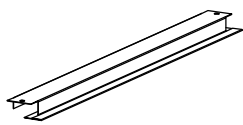
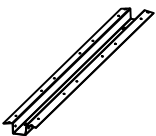



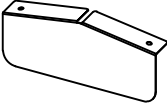

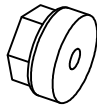

EN_ HOW TO JOIN CHANNELS (where needed).
FR_ COMMENT REJOINDRE LES CHÂÎNES (si nécessaire).
DE_ SO TRITTEN SIE KANÄLEN BEI (falls erforderlich).
ES_ CÓMO UNIRSE A LOS CANALES (cuando sea necesario).
PT_ COMO PARTICIPAR DOS CANAIS (quando necessário).
IT_ COME ISCRIVERSI AI CANALI (ove necessario).

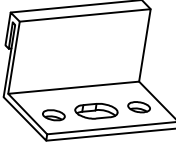
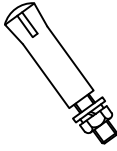

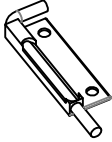
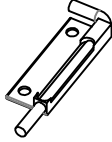
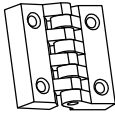





 <p>ETP1 × 2 L645</p>	 <p>EP1 × 5 L1700</p>	 <p>EP2 × 2 L1700</p>
 <p>EDP1 × 2 L1644</p>	 <p>EUF1 × 1 L1125</p>	 <p>EUF2 × 1 L1125</p>
 <p>EUF3 × 2 L363</p>	 <p>EBF1 × 1 L1125</p>	 <p>EBF2 × 1 L1125</p>
 <p>EBF3 × 2 L363</p>	 <p>EBF4 × 1 L806</p>	 <p>EBF5 × 2 L350</p>
 <p>EBF6 × 1 L1134</p>	 <p>EDF2 × 1 L1644</p>	 <p>EDF3 × 1 L1644</p>

 <p>EDF4 × 1 L1644</p>	 <p>EDF5 × 1 L1644</p>	 <p>ED1 × 2 L393</p>
 <p>ED2 × 4 L676</p>	 <p>EC1 × 1 L1134</p>	 <p>EDF1 × 4 L399.5</p>
 <p>EL1 × 4 L611</p>	 <p>EL2 × 2 L405</p>	 <p>ER1 × 1 L399</p>
 <p>ET1 × 1 L806</p>	 <p>ET2 × 1 L1700</p>	 <p>ET3 × 1 L1700</p>
 <p>EV1 × 1 L401</p>	 <p>EGL1 × 2 L1025</p>	

<p>ELG ×2</p> 	<p>EG1 ×8</p> 	<p>EH1 ×2</p> 	<p>L3 ×25 +2(Spare)</p> 
<p>LB1 ×4</p> 	<p>S3 ×90 +8(Spare)</p> 	<p>S18 ×30 +2(Spare)</p> 	<p>C7 ×3</p> 
<p>S11 ×3</p> 	<p>ED3 ×1</p> 	<p>H2 ×1</p> 	<p>H3 ×1</p> 
<p>SH4 ×4</p> 	<p>Gloves</p> 	<p>Lock</p> 	<p>S1 ×16 +1(Spare)</p> 
<p>SC04 ×4</p> 	<p>SC06 ×18 +2(Spare)</p> 		

PANEL ASSEMBLY/ ASSEMBLAGE DE PANNEAUX / PANEL-BAUGRUPPE / MONTAJE DEL PANEL / MONTAGEM DO PAINEL / ASSEMBLAGGIO DEL PANNELLO

REAR WALL/ MUR ARRIÈRE / RÜCKWAND / PARED TRASERA / PAREDE TRASEIRA / PARETE POSTERIORE

	EP1	3		EUF2	1		EBF2	1		S3	2
---	-----	---	---	------	---	---	------	---	--	----	---

Colourside/ Côté couleurs / Farbenseite / Lado del color / Lado colorido / Colourside

STEP1

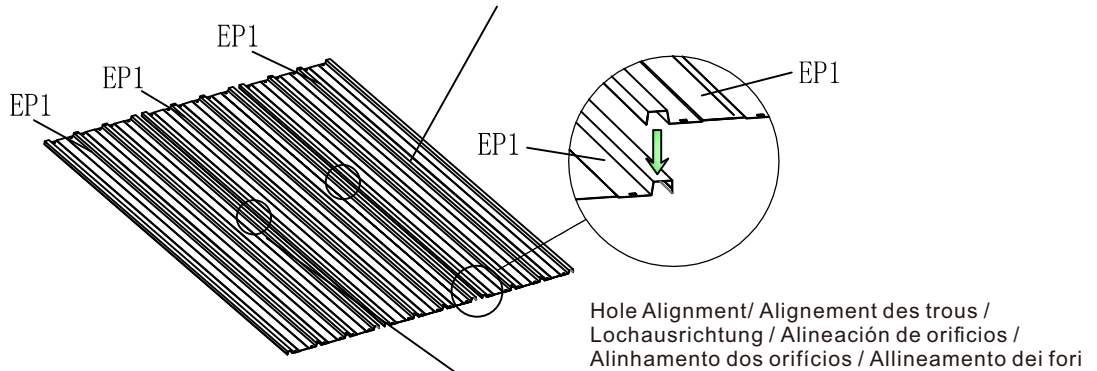

STEP2

NO HOLES/ SANS TROUS / KEINE LÖCHER / SIN AGUJEROS / SEM BURACOS / SENZA FORI

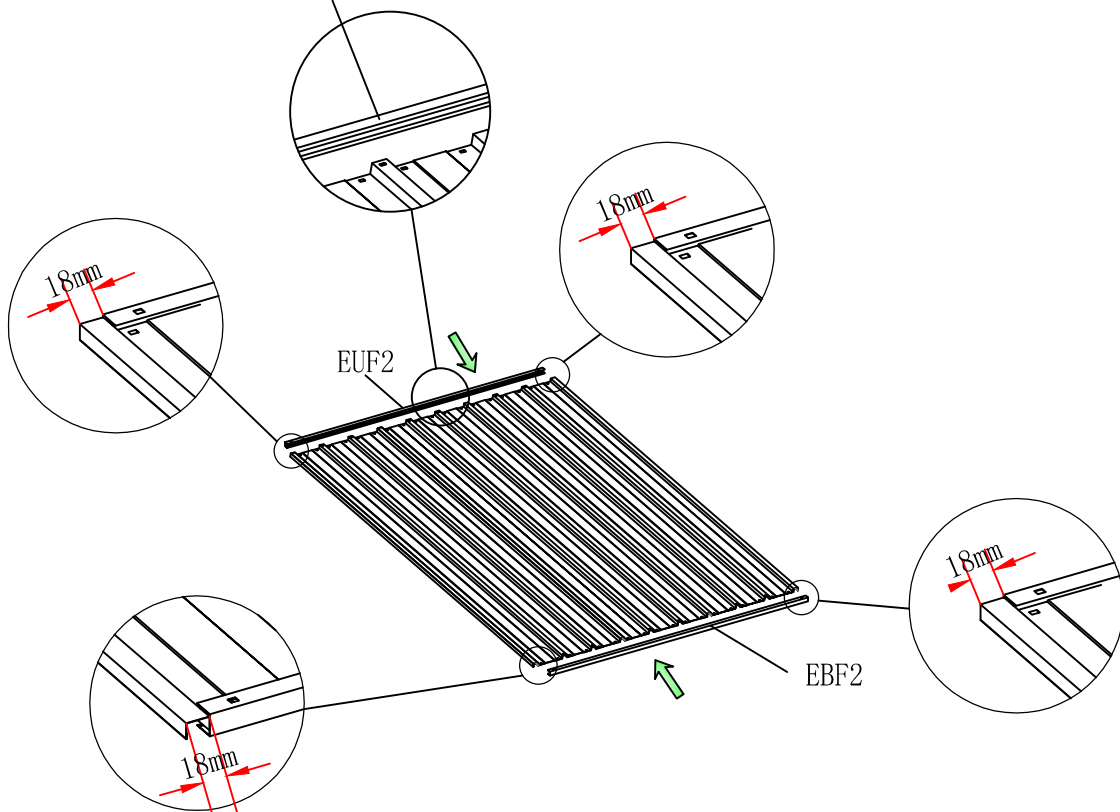

PANEL ASSEMBLY/ ASSEMBLAGE DE PANNEAUX / PANEL-BAUGRUPPE /
MONTAJE DEL PANEL / MONTAGEM DO PAINEL / ASSEMBLAGGIO DEL
PANNELLO

LEFT WALL & RIGHT WALL/ MUR GAUCHE ET MUR DROIT / LINKE WAND &
RECHTE WAND / PARED IZQUIERDA Y PARED DERECHA / PAREDE
ESQUERDA E PAREDE DIREITA / PARETE SINISTRA E PARETE DESTRA

	EP1	1		EUF3	1		EBF3	1
---	-----	---	---	------	---	---	------	---

X2

STEP1

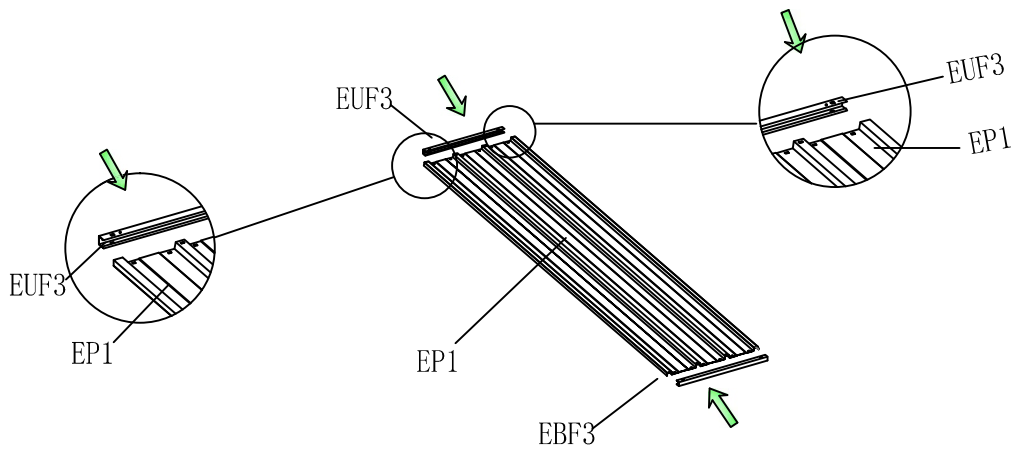



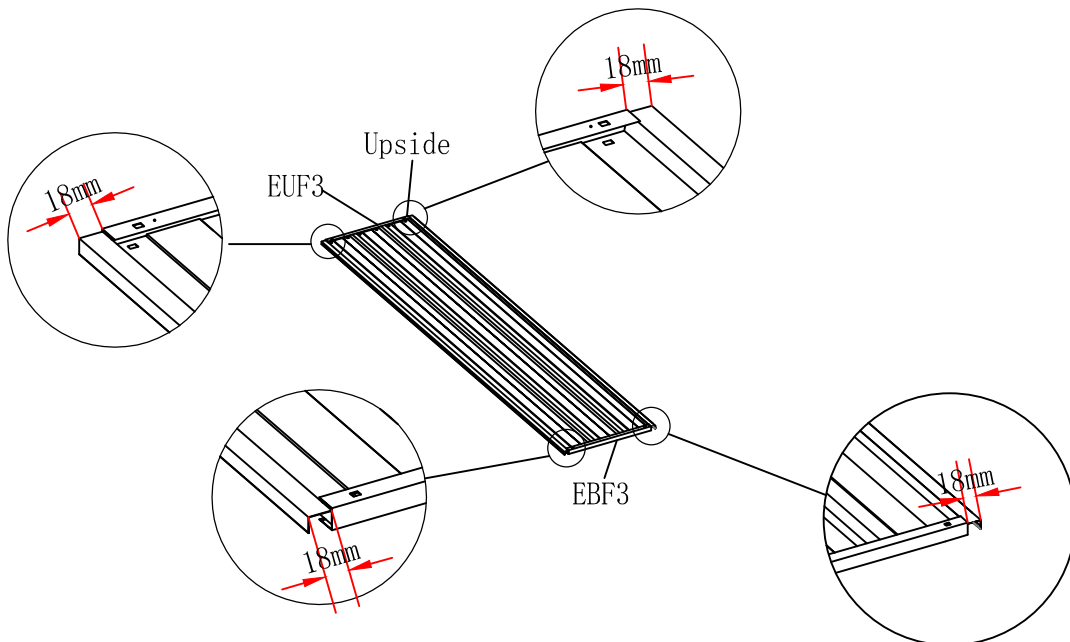



STEP2



PANEL ASSEMBLY/ ASSEMBLAGE DE PANNEAUX / PANEL-BAUGRUPPE /
MONTAJE DEL PANEL / MONTAGEM DO PAINEL / ASSEMBLAGGIO DEL
PANNELLO

FRONT WALL/ MUR AVANT / VORDERWAND / PARED FRONTAL / PAREDE
FRONTAL / PARETE FRONTALE





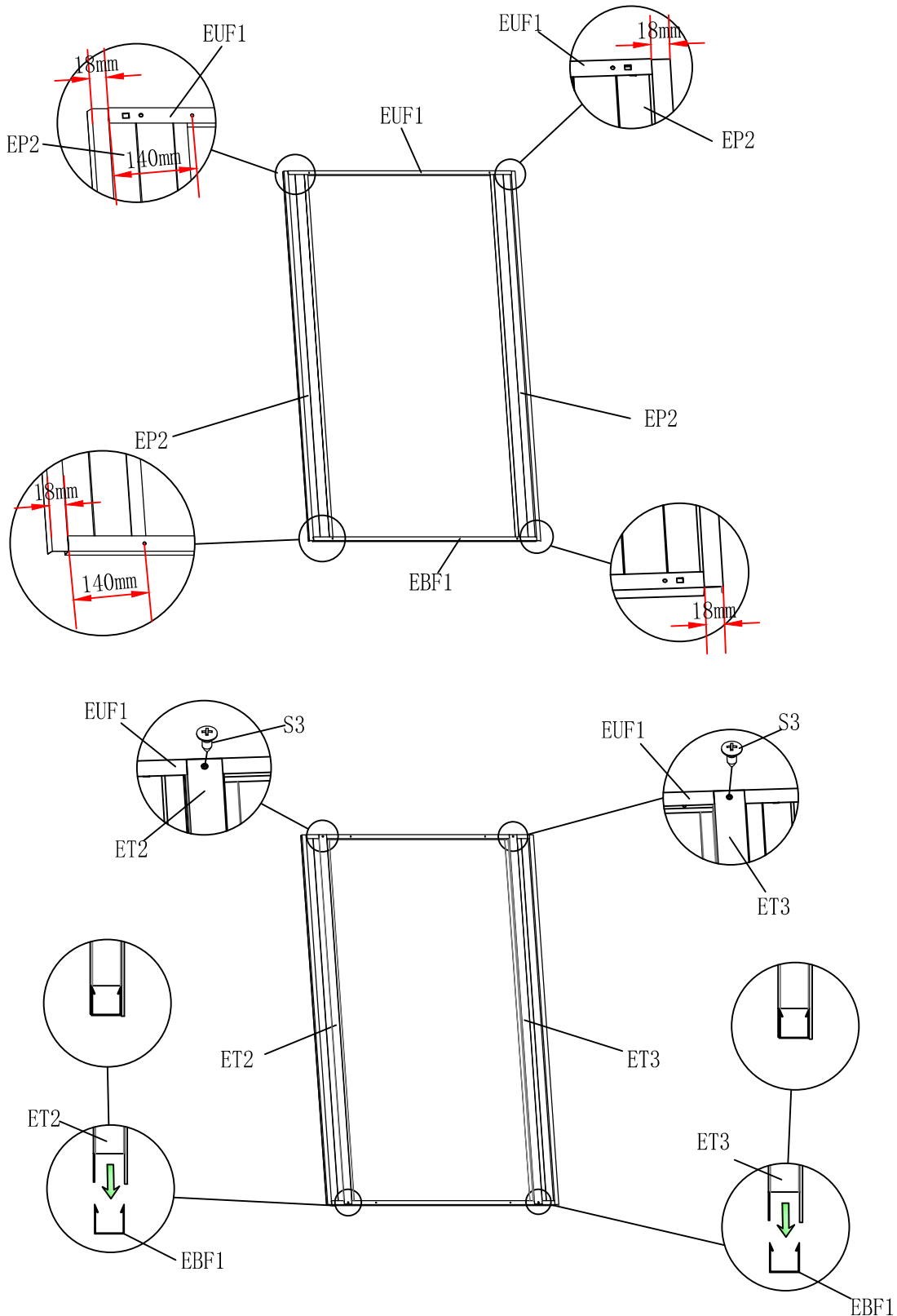





	EP2	2		S3	4		EUF1	1		EBF1	1
	ET2	1		ET3	1						

STEP1



SHED ASSEMBLY/ ASSEMBLAGE DE L'ABRI / SCHUPPENBAU / MONTAJE DEL COBERTIZO / MONTAGEM DO GALPÃO / ASSEMBLAGGIO DEL CAPANNONE



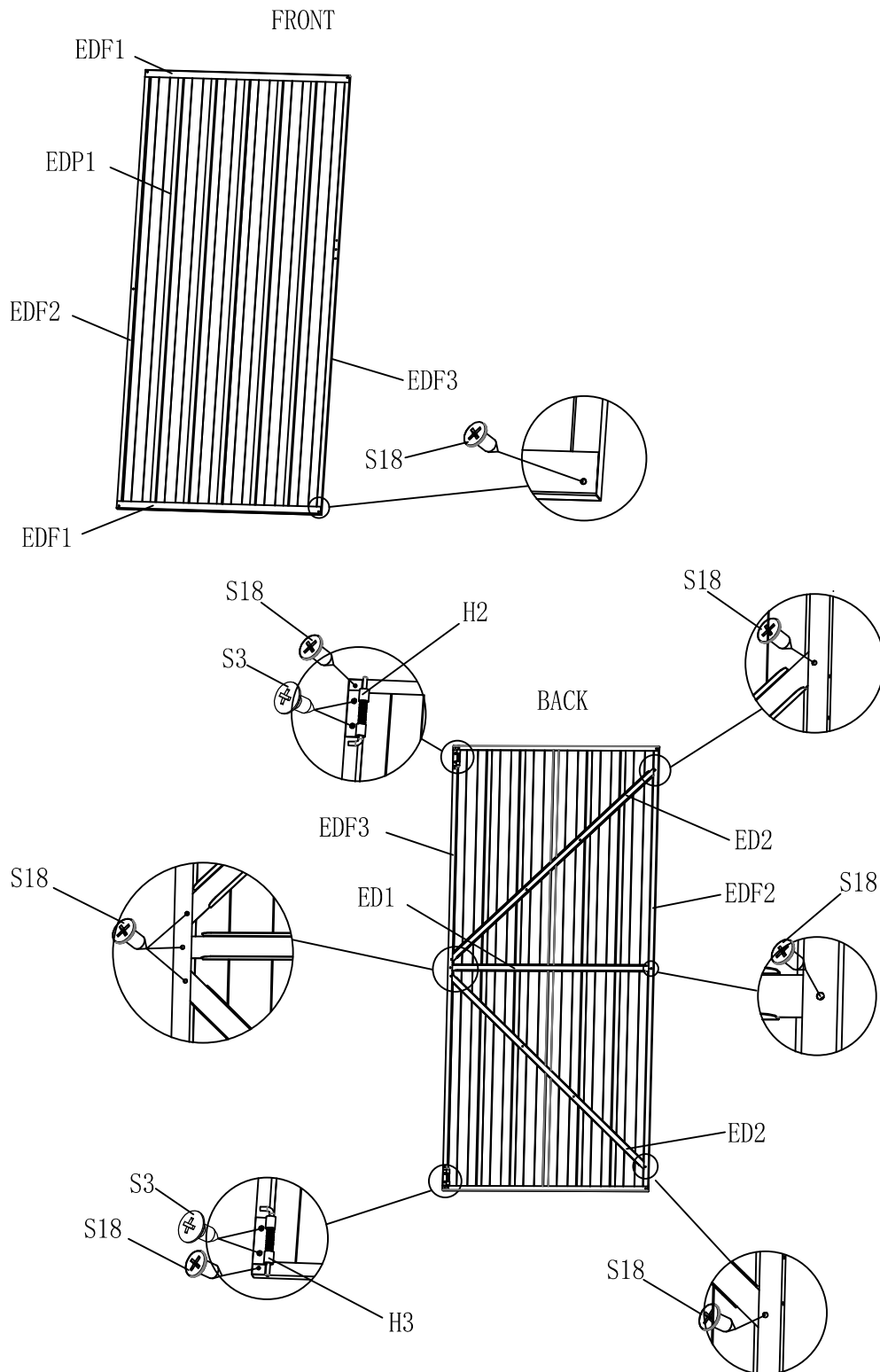

LEFT DOOR/ PORTE GAUCHE / LINKE TÜR / PUERTA IZQUIERDA / PORTA ESQUERDA / PORTA SINISTRA

	EDP1	1		EDF1	2		EDF2	1		EDF3	1		ED1	1
	ED2	2		H2	1		H3	1		S3	4		S18	14



SHED ASSEMBLY/ ASSEMBLAGE DE L'ABRI / SCHUPPENBAU / MONTAJE DEL COBERTIZO / MONTAGEM DO GALPÃO / ASSEMBLAGGIO DEL CAPANNONE

LEFT DOOR/ PORTE GAUCHE / LINKE TÜR / PUERTA IZQUIERDA / PORTA ESQUERDA / PORTA SINISTRA

	EH1	1		SH4	2		SC04	2		S3	5		SC06	4
---	-----	---	---	-----	---	---	------	---	---	----	---	---	------	---

STEP3

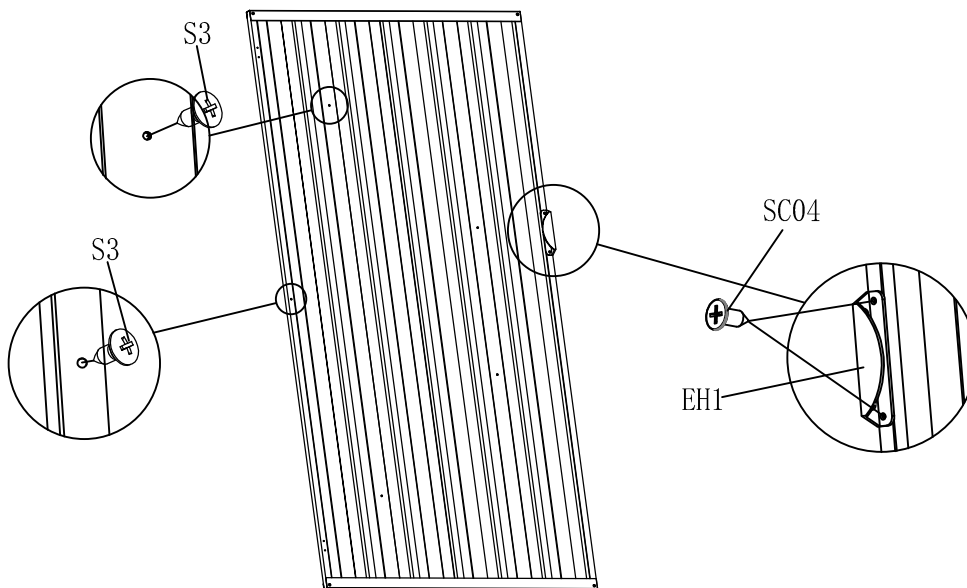



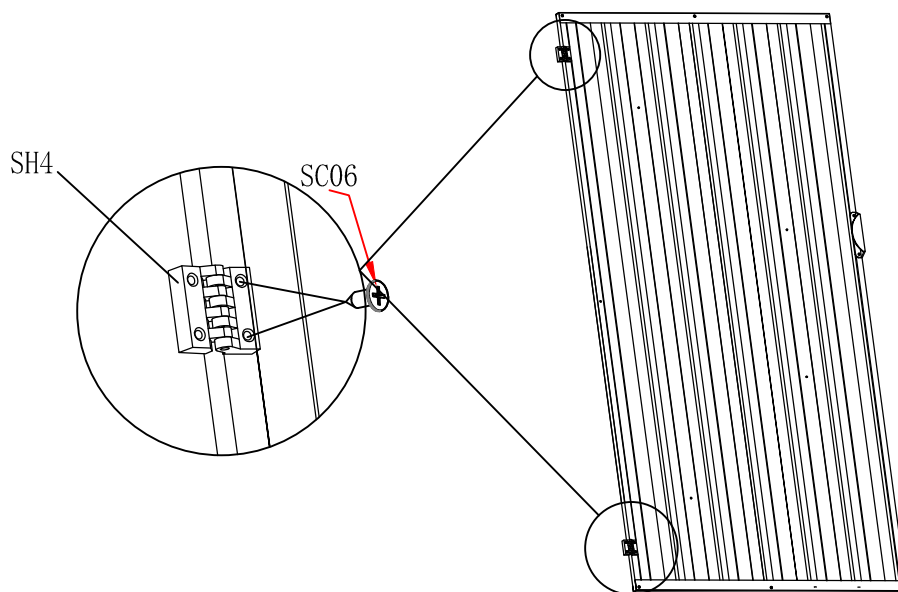



STEP4



SHED ASSEMBLY/ ASSEMBLAGE DE L'ABRI/ SCHUPPENBAU/ MONTAJE DEL COBERTIZO / MONTAGEM DO GALPÃO / ASSEMBLAGGIO DEL CAPANNONE

RIGHT DOOR/ PORTE DE DROITE / RECHTE TÜR / PUERTA DERECHA / PORTA DA DIREITA / PORTA DESTRA

	EDP1	1		EDF1	2		EDF4	1		EDF5	1		ED1	1
	ED2	2		S18	14									

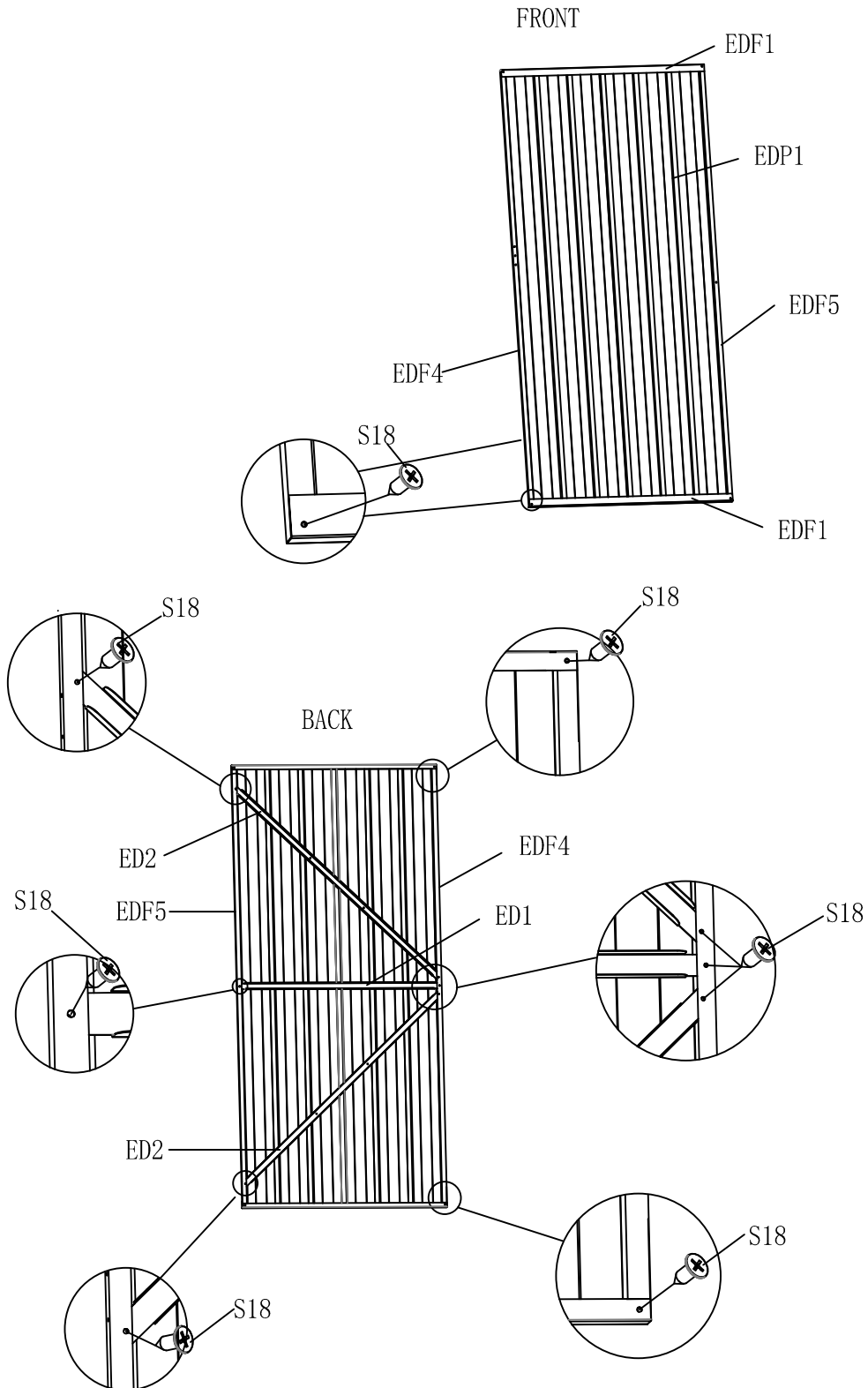

SHED ASSEMBLY/ ASSEMBLAGE DE L'ABRI / SCHUPPENBAU / MONTAJE DEL COBERTIZO / MONTAGEM DO GALPÃO / ASSEMBLAGGIO DEL CAPANNONE

RIGHT DOOR/ PORTE DE DROITE / RECHTE TÜR / PUERTA DERECHA / PORTA DA DIREITA / PORTA DESTRA

	EH1	1		SH4	2		SC04	2		S3	5		SC06	4
---	-----	---	---	-----	---	---	------	---	---	----	---	---	------	---

STEP3

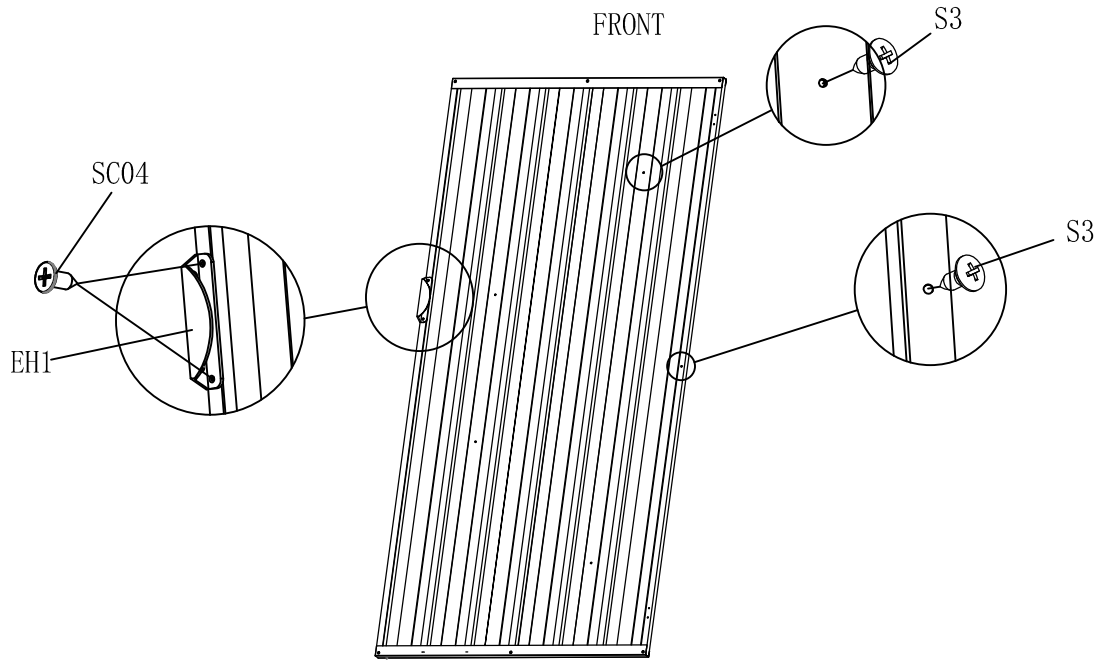

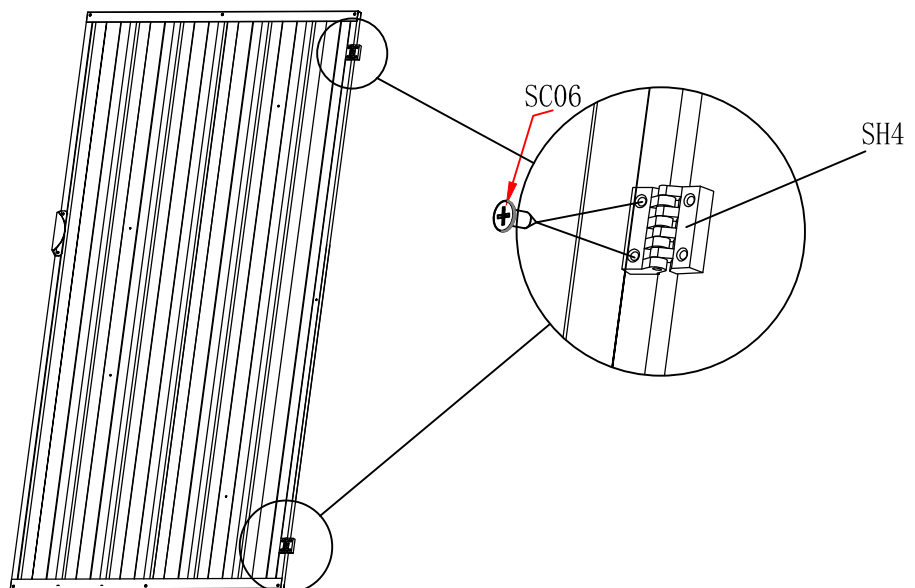

STEP4



SHED ASSEMBLY/ ASSEMBLAGE DE L'ABRI / SCHUPPENBAU / MONTAJE DEL COBERTIZO / MONTAGEM DO GALPÃO / ASSEMBLAGGIO DEL CAPANNONE

JOINING WALL/ MUR DE RACCORDEMENT / VERBINDUNGSWAND / PARED DE UNIÓN / PAREDE DE JUNÇÃO / PARETE DI GIUNZIONE

	EG1	4		S3	8
---	-----	---	---	----	---

Left wall/ Mur gauche / Linke Wand / Pared izquierda / Parede esquerda / Parete sinistra

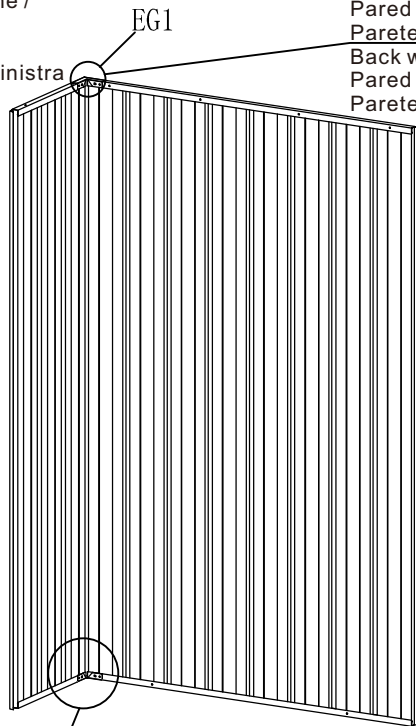

Left wall/ Mur gauche / Linke Wand / Pared izquierda / Parede esquerda / Parete sinistra
Back wall/ Mur arrière / Rückwand / Pared trasera / Parede traseira / Parete posteriore

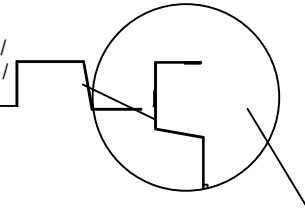

Back wall/ Mur arrière / Rückwand / Pared trasera / Parede traseira / Parete posteriore

EN_ When connecting four walls, it is recommended that the back wall be against the wall or support.
FR_ Lorsque vous reliez quatre murs, il est recommandé que le mur arrière soit contre le mur ou le support.
DE_ Beim Verbinden von vier Wänden wird empfohlen, die Rückwand an einer Wand oder Stütze anzubringen.
ES_ Al conectar cuatro paredes, se recomienda que la pared trasera quede contra la pared o el soporte.
PT_ Ao ligar quatro paredes, recomenda-se que a parede traseira fique encostada à parede ou suporte.
IT_ Quando si collegano quattro pareti, si raccomanda che la parete posteriore sia contro il muro o il supporto.

EN_ Drill S3 on color side, no need to drill the other side.
FR_ Percez le côté coloré, il n'est pas nécessaire de percer l'autre côté.
DE_ Bohren Sie S3 auf der farbigen Seite, die andere Seite muss nicht gebohrt werden.
ES_ Taladre el lado de color S3, no es necesario taladrar el otro lado.
PT_ Faça o furo S3 no lado colorido, não é necessário fazer o furo no outro lado.
IT_ Forare S3 sul lato colorato, non è necessario forare l'altro lato.

EN_ When two walls overlap, make sure side wall is outside.
FR_ Lorsque deux murs se chevauchent, assurez-vous que le mur latéral se trouve à l'extérieur.
DE_ Wenn sich zwei Wände überlappen, stellen Sie sicher, dass die Seitenwand außen liegt.
ES_ Cuando dos paredes se superponen, asegúrate de que la pared lateral quede fuera.
PT_ Quando duas paredes se sobrepõem, certifique-se de que a parede lateral fica do lado de fora.
IT_ Quando due pareti si sovrappongono, assicurarsi che la parete laterale sia all'esterno.

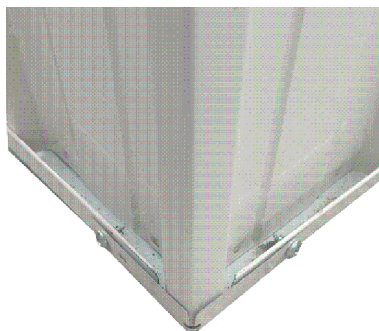
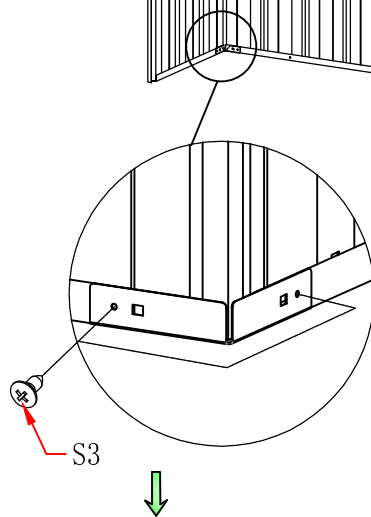





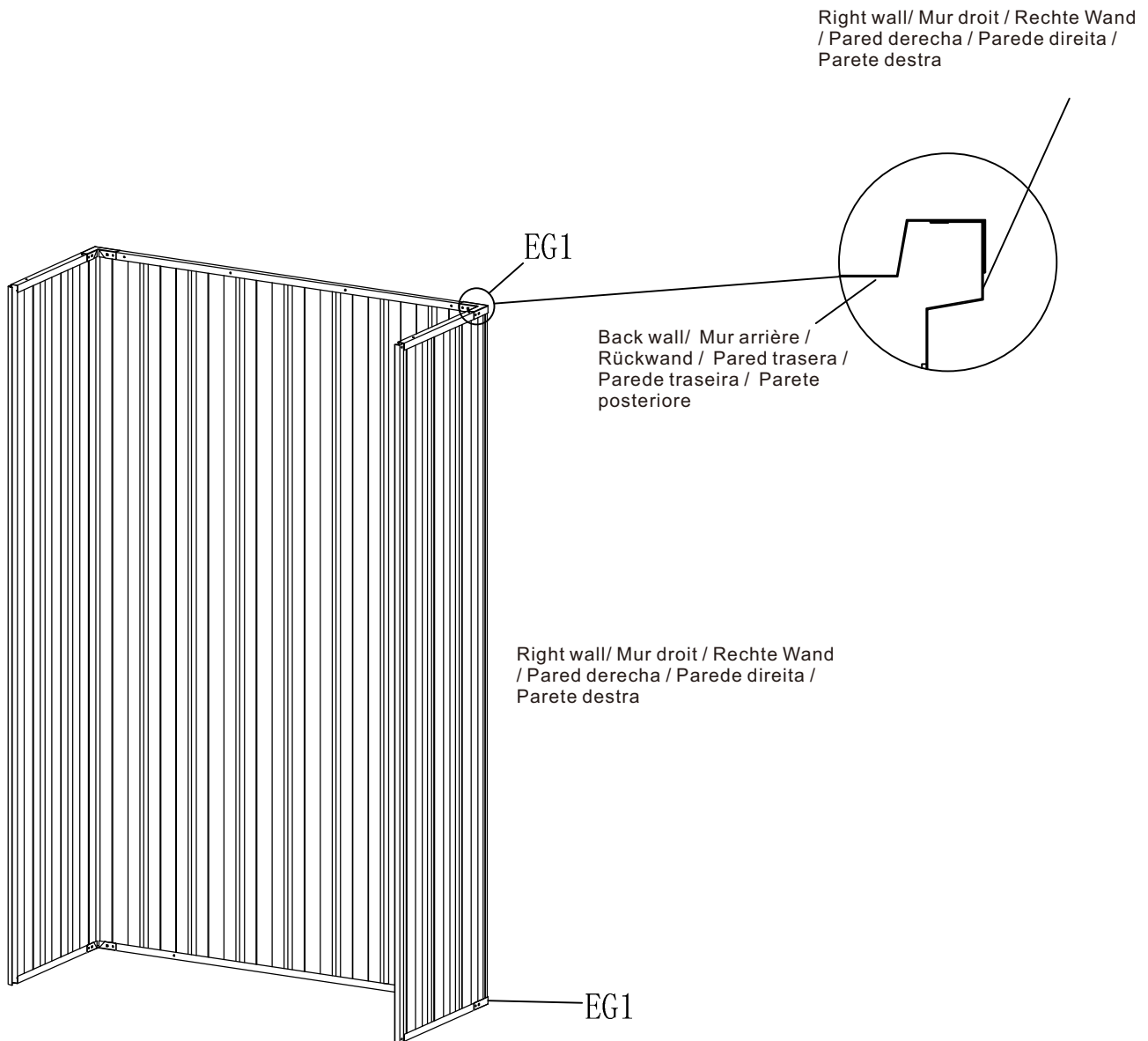

SHED ASSEMBLY/ ASSEMBLAGE DE L'ABRI / SCHUPPENBAU / MONTAJE DEL COBERTIZO / MONTAGEM DO GALPÃO / ASSEMBLAGGIO DEL CAPANNONE

JOINING WALL/ MUR DE RACCORDEMENT / VERBINDUNGSWAND / PARED DE UNIÓN / PAREDE DE JUNÇÃO / PARETE DI GIUNZIONE



SHED ASSEMBLY/ ASSEMBLAGE DE L'ABRI / SCHUPPENBAU / MONTAJE DEL COBERTIZO / MONTAGEM DO GALPÃO / ASSEMBLAGGIO DEL CAPANNONE

JOINING WALL/ MUR DE RACCORDEMENT / VERBUNDUNGSWAND / PARED DE UNIÓN / PAREDE DE JUNÇÃO / PARETE DI GIUNZIONE

	EBF5	2		EBF6	1		EC1	1		L3	15		S1	15
	S3	8												

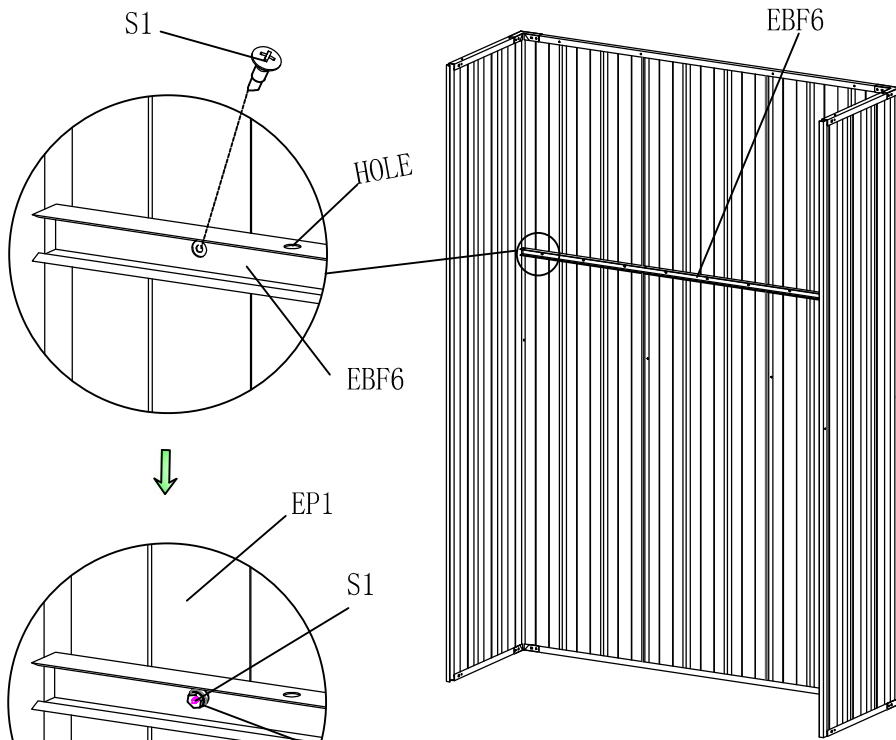

EN_ The screw is fixed from the outside to the inside.
FR_ La vis est fixée de l'extérieur vers l'intérieur.
DE_ Die Schraube wird von außen nach innen befestigt.
ES_ El tornillo se fija desde el exterior hacia el interior.
PT_ O parafuso é fixado de fora para dentro.
IT_ La vite è fissata dall'esterno verso l'interno.

EN_ EBF6 can be installed at any height you want.
FR_ L'EBF6 peut être installé à la hauteur que vous souhaitez.
DE_ EBF6 kann in jeder gewünschten Höhe installiert werden.
ES_ EBF6 se puede instalar a cualquier altura que desee.
PT_ O EBF6 pode ser instalado em qualquer altura que desejar.
IT_ EBF6 può essere installato a qualsiasi altezza desiderata.

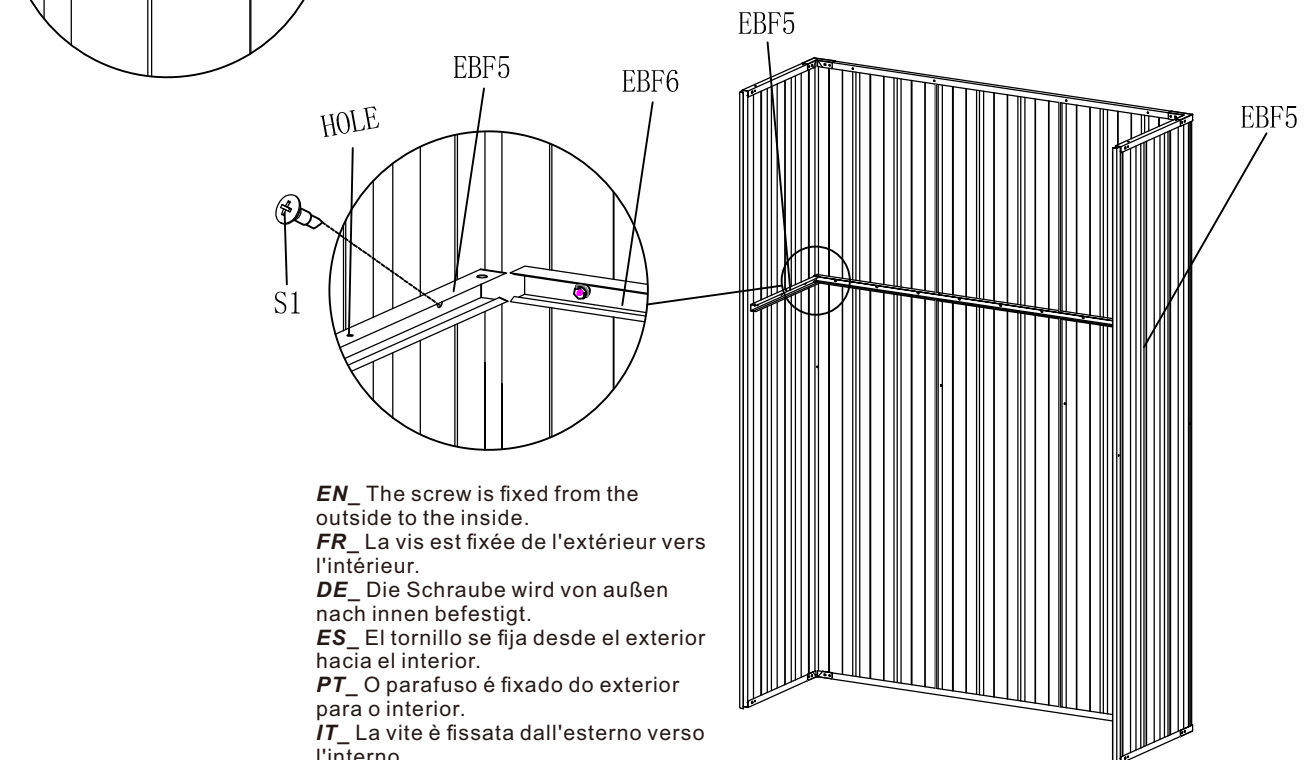

EN_ The screw is fixed from the outside to the inside.
FR_ La vis est fixée de l'extérieur vers l'intérieur.
DE_ Die Schraube wird von außen nach innen befestigt.
ES_ El tornillo se fija desde el exterior hacia el interior.
PT_ O parafuso é fixado do exterior para o interior.
IT_ La vite è fissata dall'esterno verso l'interno.

SHED ASSEMBLY/ ASSEMBLAGE DE L'ABRI / SCHUPPENBAU / MONTAJE DEL COBERTIZO / MONTAGEM DO GALPÃO / ASSEMBLAGGIO DEL CAPANNONE

JOINING WALL/ MUR DE RACCORDEMENT / VERBINDUNGSWAND / PARED DE UNIÓN / PAREDE DE JUNÇÃO / PARETE DI GIUNZIONE

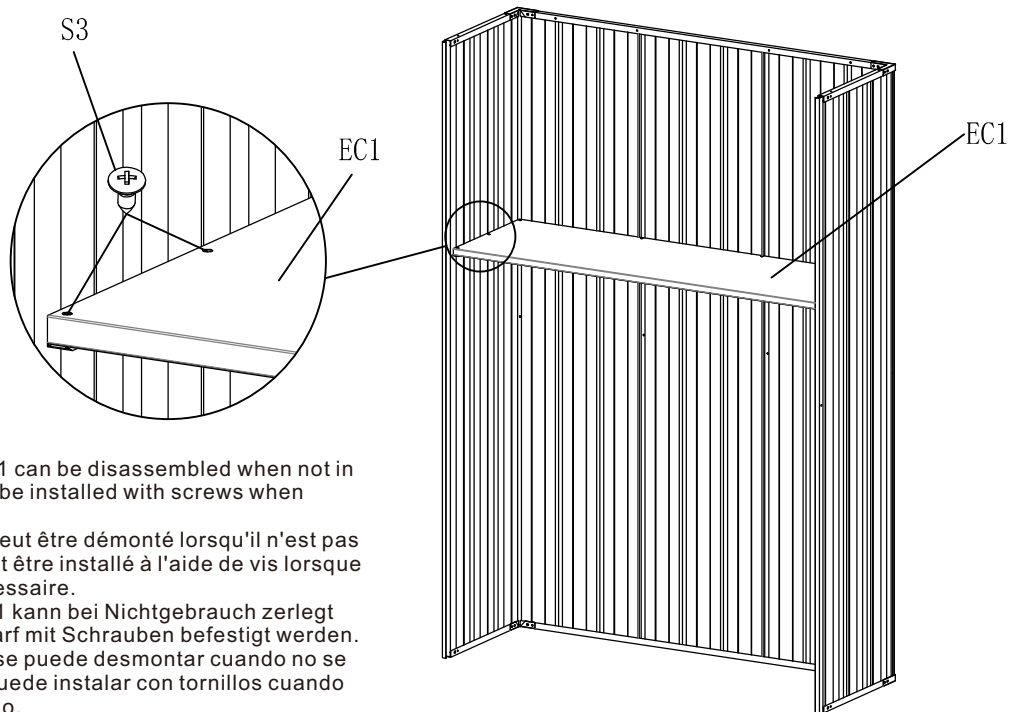

EN_ The EC1 can be disassembled when not in use and can be installed with screws when needed.

FR_ L'EC1 peut être démonté lorsqu'il n'est pas utilisé et peut être installé à l'aide de vis lorsque cela est nécessaire.

DE_ Der EC1 kann bei Nichtgebrauch zerlegt und bei Bedarf mit Schrauben befestigt werden.

ES_ El EC1 se puede desmontar cuando no se utiliza y se puede instalar con tornillos cuando sea necesario.

PT_ O EC1 pode ser desmontado quando não estiver em uso e pode ser instalado com parafusos quando necessário.

IT_ L'EC1 può essere smontato quando non viene utilizzato e può essere installato con viti quando necessario.

EN_ Note: It is recommended that the maximum load for EC1 be 30 kg.

FR_ Remarque : il est recommandé que la charge maximale pour EC1 soit de 30 kg.

DE_ Hinweis: Es wird empfohlen, dass die maximale Belastung für EC1 30 kg beträgt.

ES_ Nota: Se recomienda que la carga máxima para EC1 sea de 30 kg.

PT_ Nota: Recomenda-se que a carga máxima para EC1 seja de 30 kg.

IT_ Nota: si raccomanda che il carico massimo per EC1 sia di 30 kg.



SHED ASSEMBLY/ ASSEMBLAGE DE L'ABRI / SCHUPPENBAU / MONTAJE DEL COBERTIZO / MONTAGEM DO GALPÃO / ASSEMBLAGGIO DEL CAPANNONE

JOINING WALL/ MUR DE RACCORDEMENT / VERBINDUNGSWAND / PARED DE UNIÓN / PAREDE DE JUNÇÃO / PARETE DI GIUNZIONE

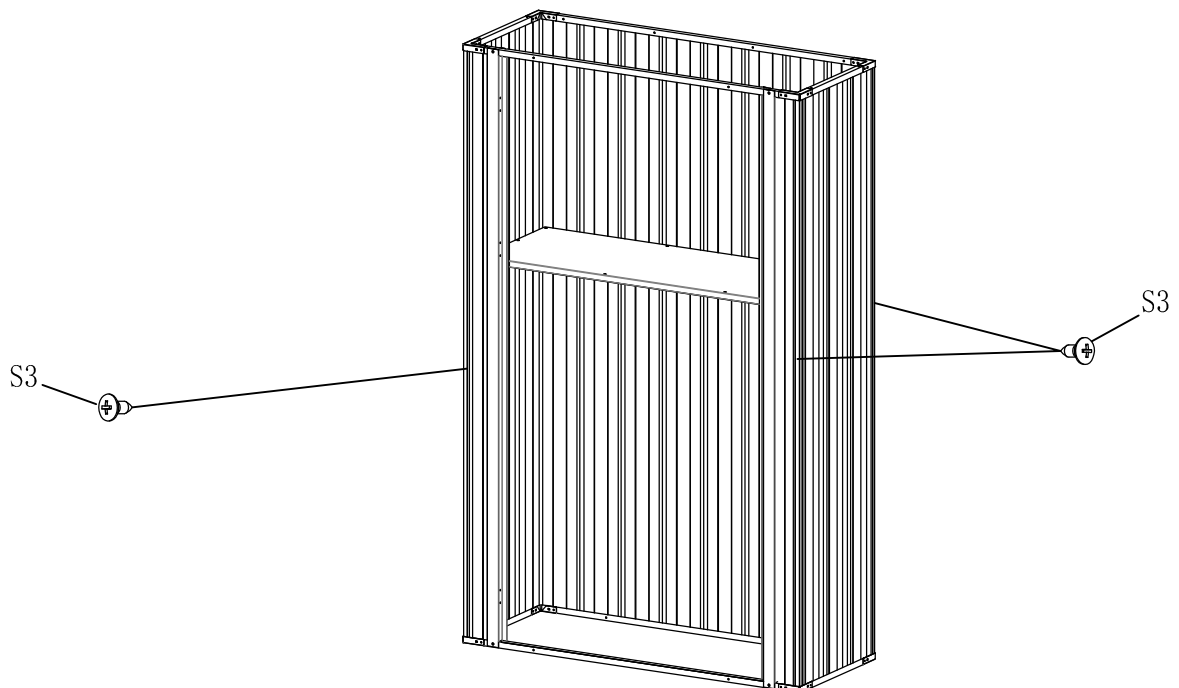
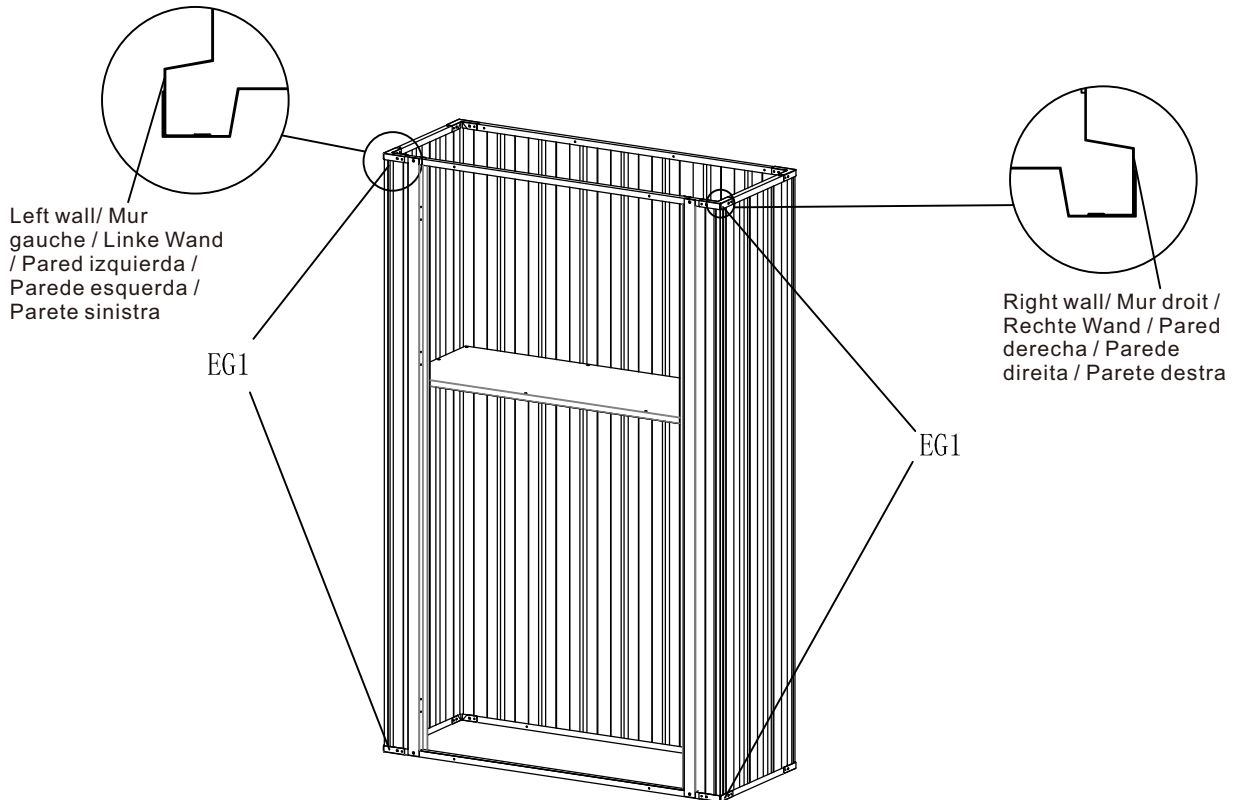
	EG1	4		S3	12
---	-----	---	---	----	----



**ANCHORING ASSEMBLY/ ENSEMBLE D'ANCRAGE/
VERANKERUNGSANORDNUNG/ CONJUNTO DE ANCLAJE/ CONJUNTO DE
ANCORAGEM/ ANCHORING ASSEMBLY**

	C7	3		S11	3
---	----	---	---	-----	---

STEP1

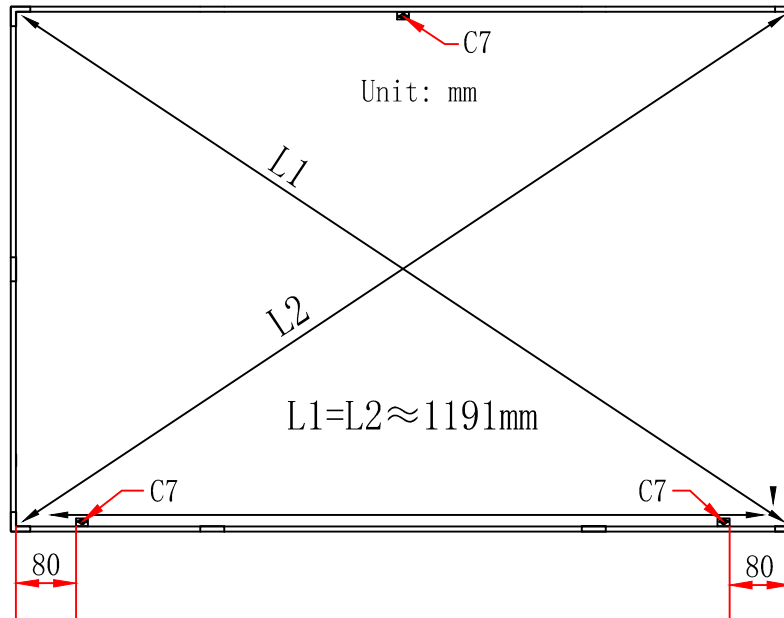

STEP2

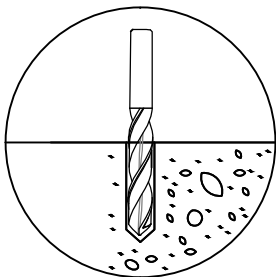

STEP3

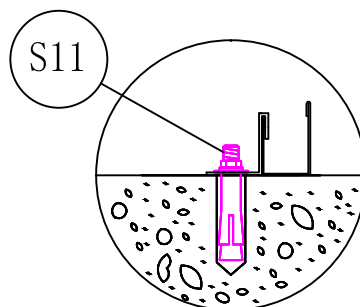

STEP4

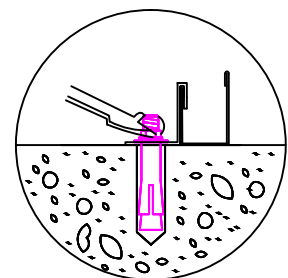

EN_1. The shed is now free standing. It is critical at this stage to ensure the shed is levelled.
2. Then measure the diagonal distance and make sure the four side walls are squared to 90 degrees.

3. Use anchor kit (C7& S11) when fixing to a concrete base. Fastening the anchor kit onto a concrete pad.

3.1 Mark the place of the anchor on the ground.

3.2 Use 10mm -0.39" concrete drill bit and drill holes 60mm-2.4" deep.

3.3 Tap concrete fixing bolts into the hole, place anchor, add washer and nut and fasten.

FR_1. Le cabanon est désormais indépendant. À ce stade, il est essentiel de s'assurer que le cabanon est bien à niveau.

2. Mesurez ensuite la distance diagonale et assurez-vous que les quatre parois latérales forment un angle de 90 degrés.

3. Utilisez le kit d'ancrage (C7& 11 S) pour la fixation sur une base en béton. Fixation du kit d'ancrage sur une dalle en béton.

3.1 Marquez l'emplacement de l'ancrage au sol.

3.2 Utilisez un foret à béton de 10 mm - 0,39« et percez des trous de 60 mm - 2,4 » de profondeur.

3.3 Enfoncez les boulons de fixation pour béton dans le trou, placez l'ancrage, ajoutez la rondelle et l'écrou, puis serrez.

DE_1. Der Schuppen steht nun frei. In dieser Phase ist es wichtig, sicherzustellen, dass der Schuppen waagrecht steht.

2. Messen Sie dann den diagonalen Abstand und stellen Sie sicher, dass die vier Seitenwände im 90-Grad-Winkel stehen.

3. Verwenden Sie bei der Befestigung auf einem Betonsockel ein Ankerset (C7& 11 S). Befestigen Sie das Ankerset auf einem Betonfundament.

3.1 Markieren Sie die Stelle für den Anker auf dem Boden.

3.2 Verwenden Sie einen 10-mm-Betonbohrer und bohren Sie 60 mm tiefe Löcher.

3.3 Schlagen Sie die Betonbefestigungsbolzen in das Loch, setzen Sie den Anker ein, fügen Sie Unterlegscheibe und Mutter hinzu und befestigen Sie ihn.

ES_1. El cobertizo ahora está independiente. En esta fase es fundamental asegurarse de que el cobertizo esté nivelado.

2. A continuación, mida la distancia diagonal y asegúrese de que las cuatro paredes laterales formen ángulos rectos de 90 grados.

3. Utilice el kit de anclaje (C7 y 11 S) cuando lo fije a una base de hormigón. Fijación del kit de anclaje a una plataforma de hormigón.

3.1 Marque la ubicación del anclaje en el suelo.

3.2 Utilice una broca para hormigón de 10 mm -0,39« y taladre agujeros de 60 mm -2,4» de profundidad.

3.3 Introduzca los pernos de fijación para hormigón en el agujero, coloque el anclaje, añada la arandela y la tuerca y apriete.

PT_1. O galpão agora está independente. É fundamental, nesta fase, garantir que o galpão esteja nivelado.

2. Em seguida, meça a distância diagonal e certifique-se de que as quatro paredes laterais estejam perpendiculares a 90 graus.

3. Use o kit de fixação (C7 e S11) ao fixar em uma base de concreto. Fixação do kit de fixação em uma base de concreto.

3.1 Marque o local da fixação no solo.

3.2 Use uma broca para betão de 10 mm - 0,39" e faça furos com 60 mm - 2,4" de profundidade.

3.3 Encaixe os parafusos de fixação para betão no furo, coloque a âncora, adicione a anilha e a porca e aperte.

IT_1. Il capanno è ora indipendente. In questa fase è fondamentale assicurarsi che il capanno sia livellato.

2. Quindi misurare la distanza diagonale e assicurarsi che le quattro pareti laterali siano perpendicolari a 90 gradi.

3. Utilizzare il kit di ancoraggio (C7 e \$11) per il fissaggio su una base in cemento. Fissaggio del kit di ancoraggio su una base in cemento.





3.1 Segnare la posizione dell'ancoraggio sul terreno.

3.2 Utilizzare una punta da trapano per calcestruzzo da 10 mm - 0,39" e praticare fori profondi 60 mm - 2,4".

3.3 Inserire i bulloni di fissaggio per calcestruzzo nel foro, posizionare l'ancoraggio, aggiungere la rondella e il dado e serrare.

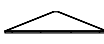
SHED ASSEMBLY/ ASSEMBLAGE DE L'ABRI / SCHUPPENBAU / MONTAJE DEL COBERTIZO / MONTAGEM DO GALPÃO / MONTAGGIO DEL CAPANNONE

TRIANGLE/ TRIANGLE / DREIECK / TRIÁNGULO / TRIÂNGULO / TRIANGOLO

	EGL1	2		ET1	1		EBF4	1		S3	12
---	------	---	---	-----	---	---	------	---	--	----	----

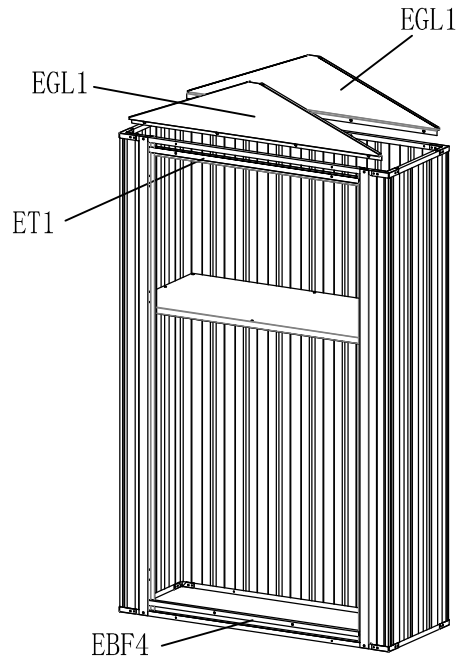

STEP1

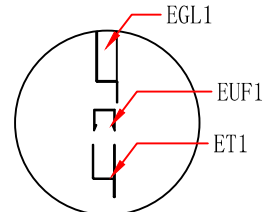

STEP2-1

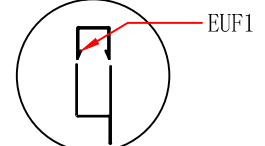

STEP2-2

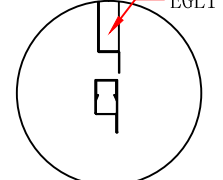

STEP3

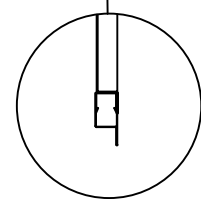

STEP4

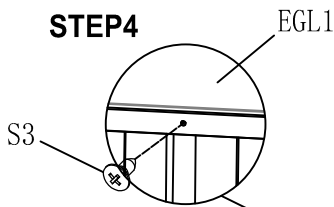

STEP5

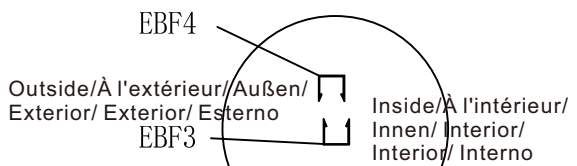

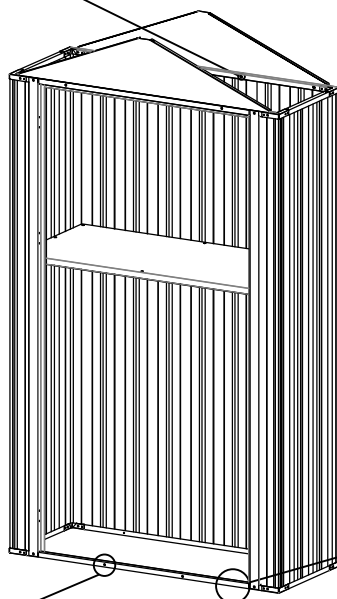
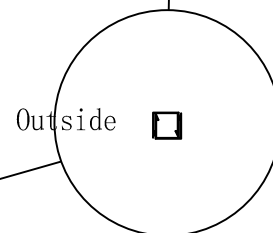

STEP6





SHED ASSEMBLY/ ASSEMBLAGE DE L'ABRI / SCHUPPENBAU / MONTAJE DEL COBERTIZO / MONTAGEM DO GALPÃO / MONTAGGIO DEL CAPANNONE

MAIN BEAM/ MAIN BEAM / Hauptstrahl / VIGA PRINCIPAL / VIGA PRINCIPAL / MAIN BEAM

	EV1	1		S3	4
---	-----	---	---	----	---

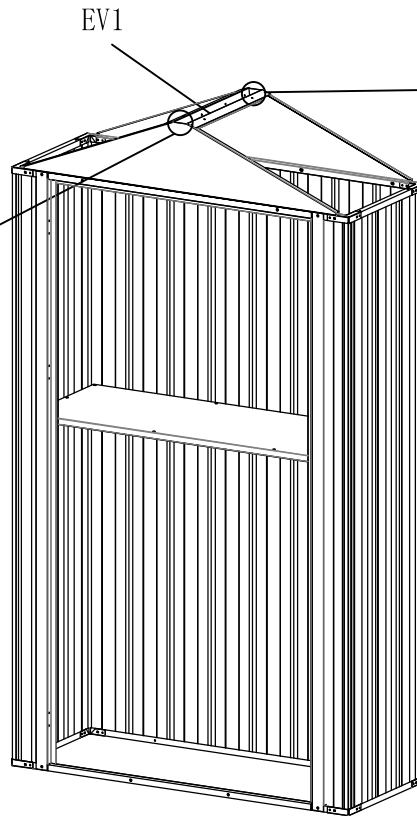
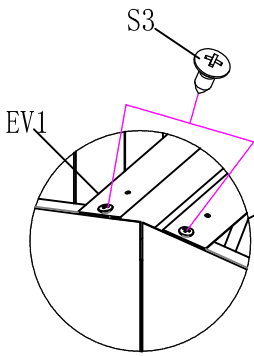
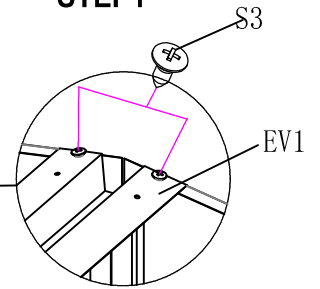
STEP1



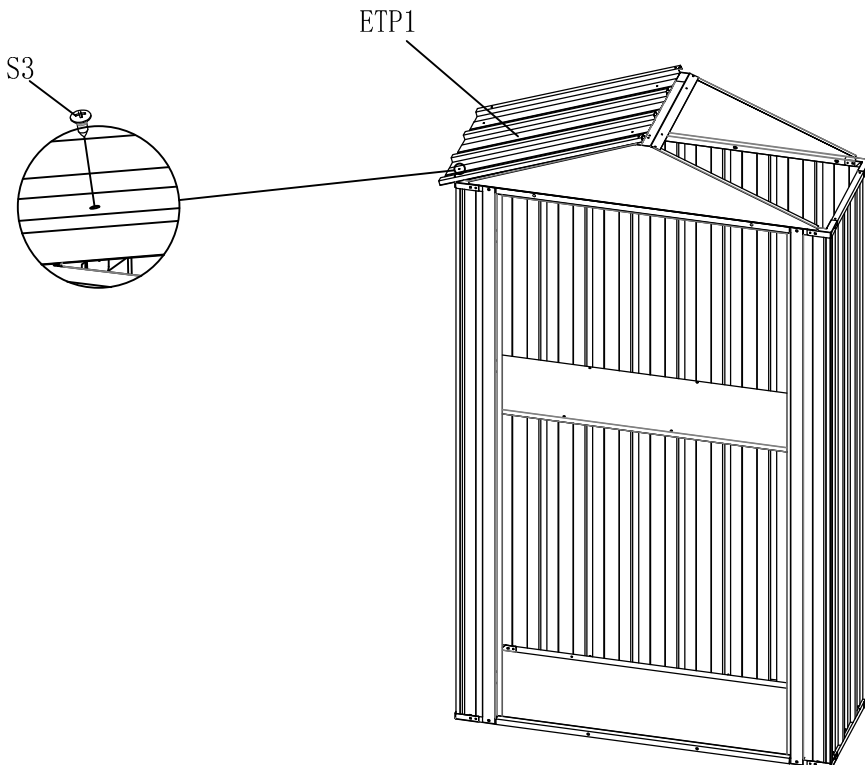

	S3	4		ETP1	1
---	----	---	---	------	---



SHED ASSEMBLY/ ASSEMBLAGE DE L'ABRI / SCHUPPENBAU / MONTAJE DEL COBERTIZO / MONTAGEM DO GALPÃO / MONTAGGIO DEL CAPANNONE

ROOF PANEL/ PANNEAU DE TOIT / DACHBAUELEMENT / PANEL DE TECHO / PAINEL DE TELHADO / PANNELLO PER TETTO

	S3	4		ETP1	1
---	----	---	---	------	---

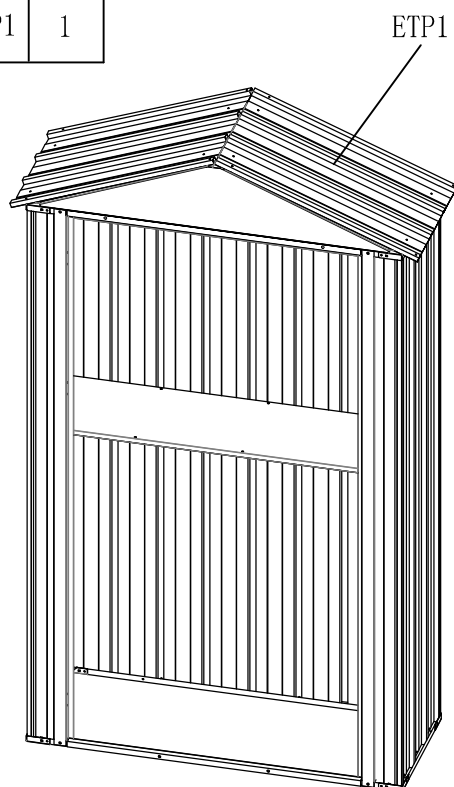

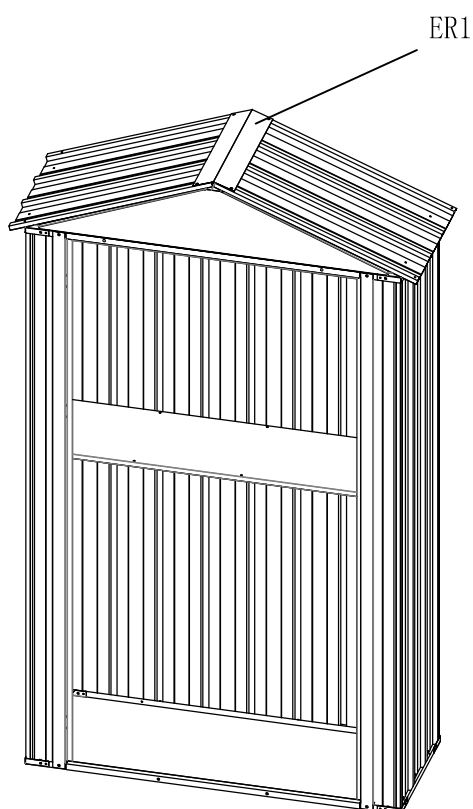

	ER1	1
---	-----	---





SHED ASSEMBLY/ ASSEMBLAGE DE L'ABRI / SCHUPPENBAU / MONTAJE DEL COBERTIZO / MONTAGEM DO GALPÃO / MONTAGGIO DEL CAPANNONE

ROOF PANEL/ PANNEAU DE TOIT / DACHBAUELEMENT / PANEL DE TECHO / PAINEL DE TELHADO / PANNELLO PER TETTO

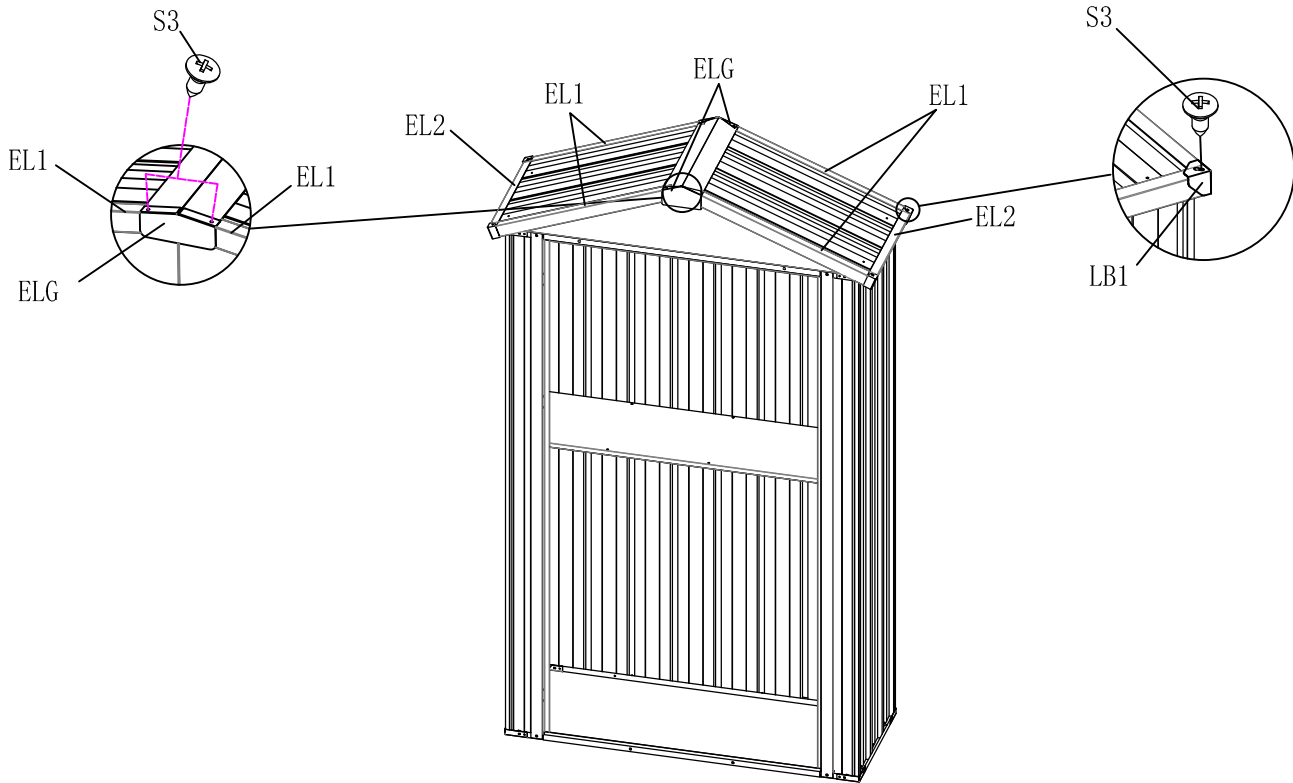
	EL1	4		EL2	2		ELG	2		S3	8		LB1	4
---	-----	---	---	-----	---	---	-----	---	---	----	---	---	-----	---



	ED3	1		S3	2
---	-----	---	---	----	---

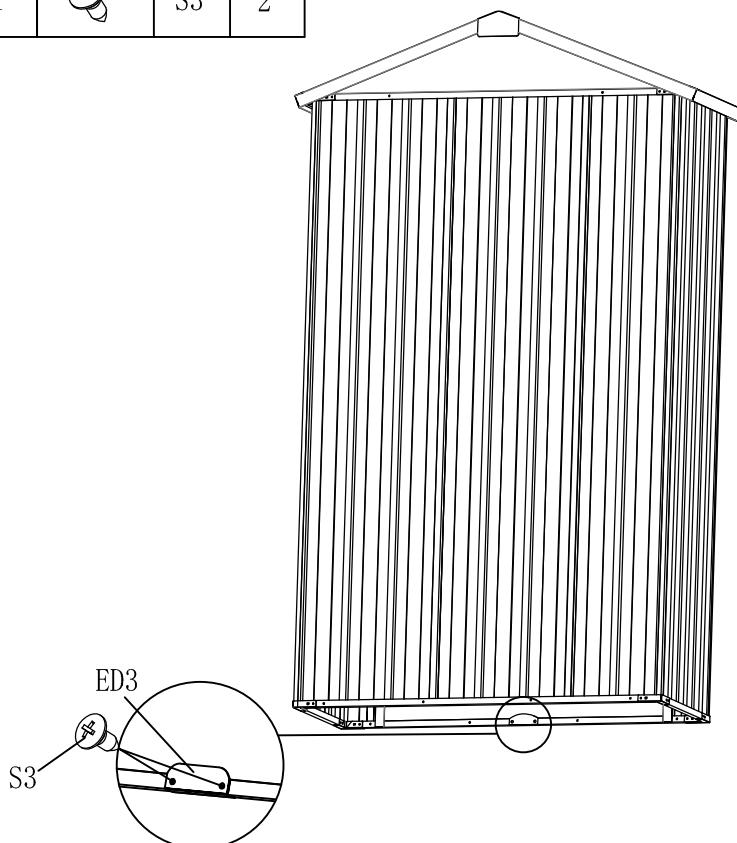

SHED ASSEMBLY/ ASSEMBLAGE DE L'ABRI / SCHUPPENBAU / MONTAJE DEL COBERTIZO / MONTAGEM DO GALPÃO / MONTAGGIO DEL CAPANNONE

ROOF PANEL/ PANNEAU DE TOIT / DACHBAUELEMENT / PANEL DE TELHO / PAINEL DE TELHADO / PANNELLO PER TETTO

	SC06	8
---	------	---

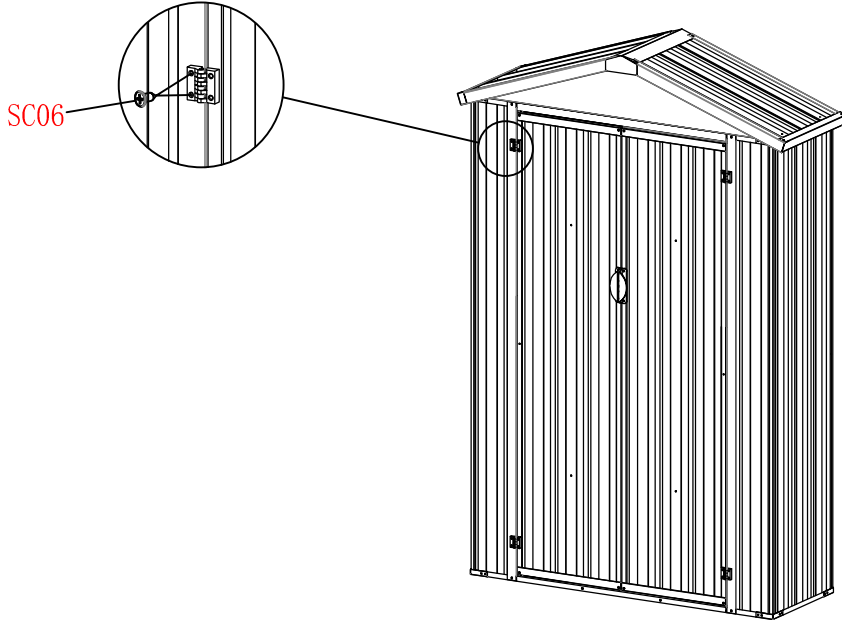

	L3	8
---	----	---

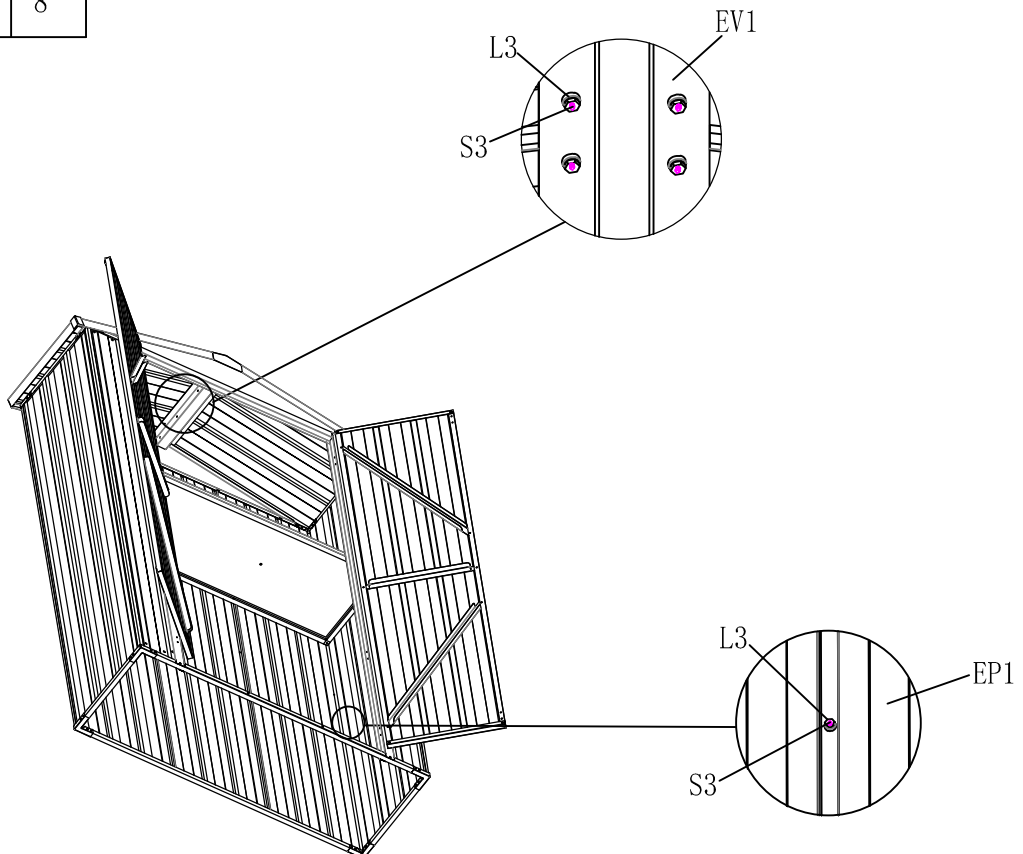

If you have any questions, please contact our customer care center, Our contact details are below:

US

 001-877-644-9366

 customerservice@aosom.com

Imported by Aosom LLC
7777 Center Ave. Suite 430
Huntington Beach, CA 92647-9998 USA
MADE IN CHINA

If you have any questions, please contact our customer care center, Our contact details are below:

CA

 416-792-6088

 customerservice@aosom.ca

Imported by Aosom Canada Inc.
7270 Woodbine Avenue, Unit 307, Markham,
Ontario Canada L3R 4B9
MADE IN CHINA

Si vous avez la moindre question, veuillez contacter notre centre d'assistance à la clientèle, Nos coordonnées sont les suivantes:

 416-792-6088

 customerservice@aosom.ca

Importé par Aosom Canada Inc.
7270 Woodbine Avenue, unité 307,
Markham, Ontario Canada L3R 4B9
FABRIQUÉ EN CHINE

Si tiene alguna pregunta, comuníquese con nuestro Centro de Atención al Cliente, Nuestros datos de contacto son los siguientes:

ES

 0034-931294512

 atencioncliente@aosom.es

IMPORTADOR/Fabricante/REP:
SPANISH AOSOM, S.L.
C/ROC GROS, N°15.08550, ELS HOSTALET DE
BALENYÀ, SPAIN.
B66295775
HECHO EN CHINA

Se tiver alguma dúvida, por favor contacte o nosso Centro de Atendimento ao Cliente, Os nossos dados de contacto são os seguintes:

 0034-931294512

 info@aosom.pt.

IMPORTADOR/Fabricante/REP:
SPANISH AOSOM, S.L.
C.ROC GROS N.15, 08550. ELS HOSTALET DE
BALENYÀ
FEITO NA CHINA

In caso di dubbio, si prega di contattare il nostro centro assistenza clienti, I nostri dettagli di contatto sono di seguito:

IT

 0039-0249471447

 clienti@aosom.it

IMPORTATO DA/Produttore/REP:
AOSOM Italy srl
Centro Direzionale Milanofiori
Strada 1 Palazzo F1
20057 Assago (MI)
P.I.: 08567220960
FATTO IN CINA

If you have any questions, please contact our customer care center, Our contact details are below:

UK

 0044-800-240-4004

 enquiries@mhstar.co.uk

IMPORTER ADDRESS:
MH STAR UK Ltd
1 Northampton Cross Logistics Park
Northampton Cross Road
Northampton
NN4 9FH
MADE IN CHINA

Wenn Sie Fragen haben, wenden Sie sich bitte an unser Kundendienstzentrum, Unsere Kontaktdaten stehen unten:

DE

 0049-0(40)-87408465

 service@aosom.de

ADRESSE DES IMPORTEURE/Hersteller/REP:
MH Handel GmbH
Wendenstraße 309
D-20537 Hamburg
Germany
IN CHINA HERGESTELLT

Si vous avez la moindre question, veuillez contacter notre centre d'assistance à la clientèle, Nos coordonnées sont les suivantes:

FR

 0033-1-84166106

 aosom@mhfrance.fr

Importé par/Fabricant/REP:
MH FRANCE
2 Rue Maurice Hartmann
92130 Issy Les Moulineaux
France
FABRIQUÉ EN CHINE



FR

**DONNEZ
OU
RECYCLEZ**



ASSOCIATION

OU



LIVRAISON

OU



DÉCHÈTERIE

Adresses sur quefairedemesdechets.fr