

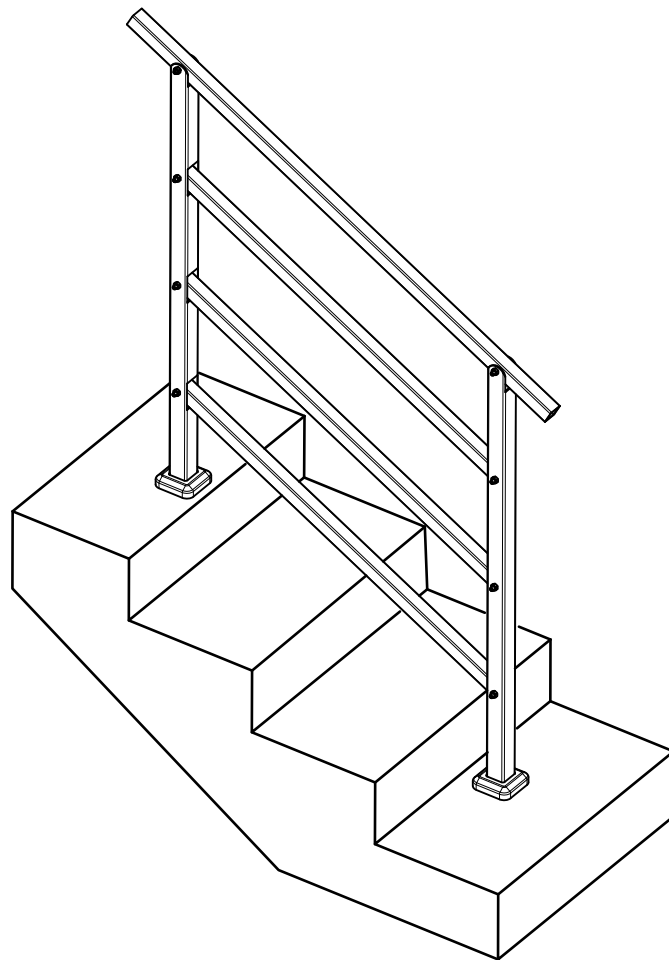

IN251000538V01

B70-085V00**03**

STEPS



0.5 HR



EN_ IMPORTANT, RETAIN FOR FUTURE REFERENCE: READ CAREFULLY.

FR_ IMPORTANT: A LIRE ATTENTIVEMENT ET À CONSERVER POUR CONSULTATION ULTÉRIEURE.

ES_ IMPORTANTE, LEA Y GUARDE PARA FUTURAS REFERENCIAS.

PT_ IMPORTANTE: LEIA ATENTAMENTE E GUARDE PARA CONSULTA FUTURA.

DE_ WICHTIG! SORGFÄLTIG LESEN UND FÜR SPÄTER NACHSCHLAGEN AUFBEWAHREN.

IT_ IMPORTANTE! CONSERVARE IL PRESENTE MANUALE PER FUTURO RIFERIMENTO E LEGGERLO ATTENTAMENTE.

RO_ IMPORTANT: CITIȚI CU ATENȚIE ȘI PĂSTRAȚI PENTRU CONSULTARE VIITOARE.

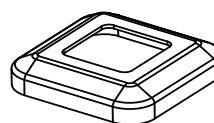
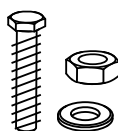
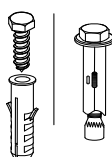
A x 2**B** x 1**C** x 3**D** x 2**G** x 8**M/N** x 8**K** x 1

EN_Tips: Avoiding mistakes, when processing the first and second step, we suggest do not connect parts tightly.

FR_Conseils : pour éviter les erreurs lors des première et deuxième étapes, nous vous recommandons de ne pas assembler les pièces de manière trop serrée.

ES_Consejos: Para evitar errores, al procesar el primer y segundo paso, recomendamos no conectar las piezas con demasiada fuerza.

PT_Dicas: Para evitar erros, ao processar a primeira e a segunda etapas, sugerimos não apertar muito as peças.

DE_Tipps: Um Fehler zu vermeiden, empfehlen wir, bei der Bearbeitung des ersten und zweiten Schritts die Teile nicht fest miteinander zu verbinden.

IT_Suggerimenti: per evitare errori, durante l'esecuzione del primo e del secondo passaggio, si consiglia di non collegare saldamente le parti.

RO_Sfaturi: Pentru a evita greșelile, vă recomandăm să nu strângeți prea tare piesele în timpul primelor două etape.

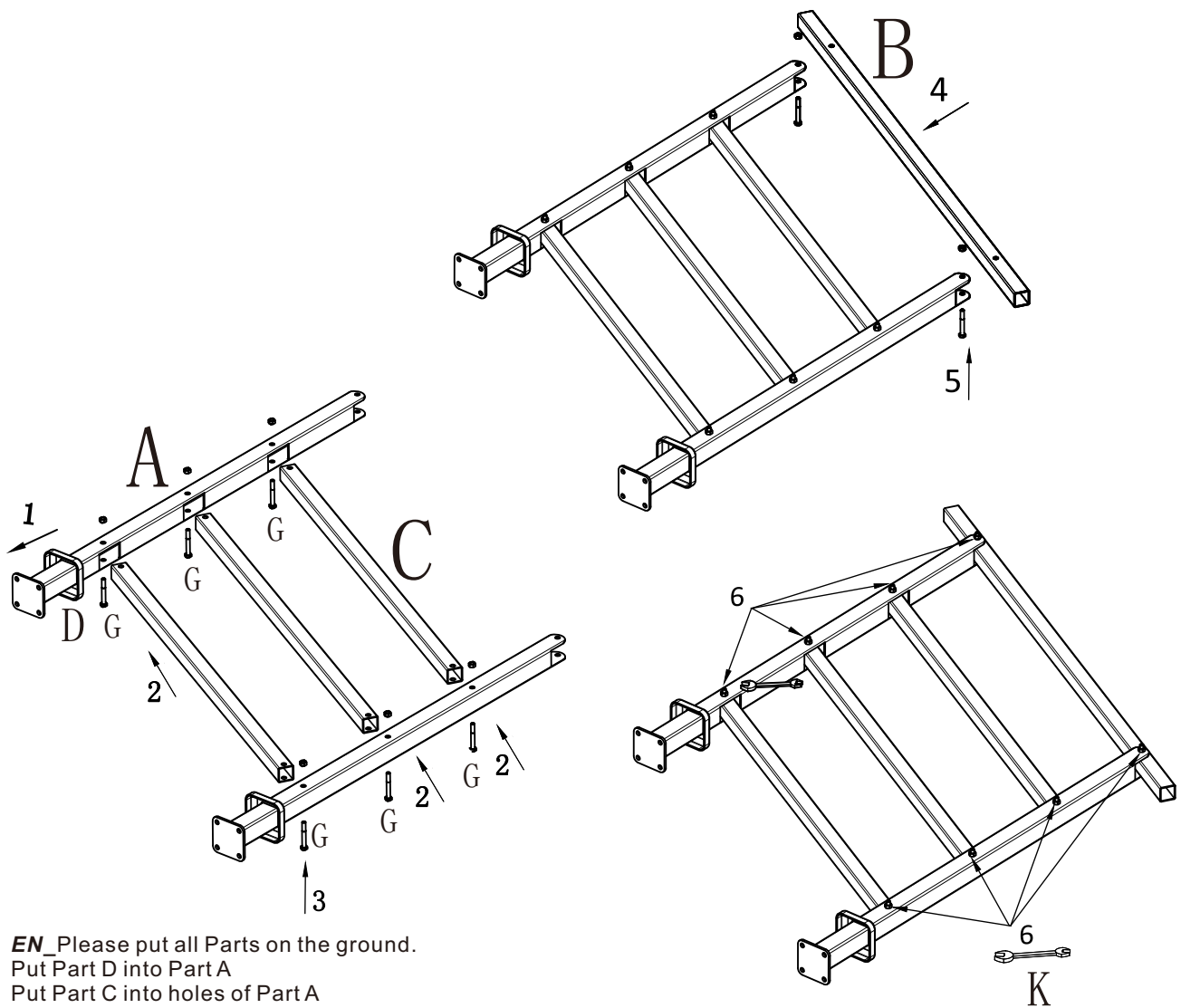

EN_ Please put all Parts on the ground.

Put Part D into Part A

Put Part C into holes of Part A

Connect Part B and Part A with Part G

Connect Part C and Part A with Part G

FR_ Veuillez poser toutes les pièces au sol.

Insérez la pièce D dans la pièce A.

Insérez la pièce C dans les trous de la pièce A.

Reliez la pièce B et la pièce A à l'aide de la pièce G.

Reliez la pièce C et la pièce A à l'aide de la pièce G.

ES_ Coloque todas las piezas en el suelo.

Introduzca la pieza D en la pieza A.

Introduzca la pieza C en los orificios de la pieza A.

Conecte la pieza B y la pieza A con la pieza G.

Conecte la pieza C y la pieza A con la pieza G.

PT_ Coloque todas as peças no chão.

Coloque a peça D na peça A.

Coloque a peça C nos orifícios da peça A.

Ligue a peça B e a peça A com a peça G.

Ligue a peça C e a peça A com a peça G.

DE_ Bitte legen Sie alle Teile auf den Boden.

Setzen Sie Teil D in Teil A ein.

Setzen Sie Teil C in die Löcher von Teil A ein.

Verbinden Sie Teil B und Teil A mit Teil G.

Verbinden Sie Teil C und Teil A mit Teil G.

IT_ Si prega di appoggiare tutti i componenti sul pavimento.

Inserire il componente D nel componente A.

Inserire il componente C nei fori del componente A.

Collegare il componente B e il componente A con il componente G.

Collegare il componente C e il componente A con il componente G.

RO_ Vă rugăm să așezați toate piesele pe podea.

Introduceți piesa D în piesa A

Introduceți piesa C în orificiile piesei A

Conectați piesa B și piesa A cu piesa G

Conectați piesa C și piesa A cu piesa G

EN_ - Place the handrail on suitable stairs

- Screw Part G by Part K

- Mark hole sites on stairs tracing four holes of Part A

- Leave the handrail alone and drill down according to the mark with a 12 MM driller Align the handrail and holes, Knock nails(part M)into the ground with hammer(Cement floor and marble floor, please using Part N; Timber floor, please using Part M)

- After the assembly is completed, put the J on both ends of G for protection.

FR_ - Placez la rampe sur les escaliers appropriés

- Vissez la pièce G à la pièce K

- Marquez l'emplacement des trous sur les escaliers en traçant les quatre trous de la pièce A

- Laissez la rampe en place et percez selon les marques à l'aide d'un foret de 12 mm. Alignez la rampe et les trous, enfoncez les clous (pièce M) dans le sol à l'aide d'un marteau (pour les sols en ciment et en marbre, veuillez utiliser la pièce N ; pour les sols en bois, veuillez utiliser la pièce M)

- Une fois l'assemblage terminé, placez la pièce J aux deux extrémités de la pièce G pour les protéger.

ES_ - Coloque el pasamanos en las escaleras adecuadas.

- Atornille la pieza G a la pieza K.

- Marque los puntos de los agujeros en las escaleras trazando los cuatro agujeros de la pieza A.

- Deje el pasamanos en su sitio y taladre según las marcas con una broca de 12 mm. Alinee el pasamanos y los agujeros, clave los clavos (pieza M) en el suelo con un martillo (en suelos de cemento y mármol, utilice la pieza N; en suelos de madera, utilice la pieza M).

- Una vez completado el montaje, coloque la pieza J en ambos extremos de la pieza G para protegerla.

PT_ - Coloque o corrimão em escadas adequadas

- Aparafuse a peça G à peça K

- Marque os locais dos furos nas escadas, traçando quatro furos da peça A

- Deixe o corrimão sozinho e perfure de acordo com a marca com uma broca de 12 mm Alinhe o corrimão e os furos, martele os pregos (peça M) no chão com um martelo (para pisos de cimento e mármore, use a peça N; para pisos de madeira, use a peça M)

- Após a montagem estar concluída, coloque o J em ambas as extremidades de G para proteção.

DE_ - Befestigen Sie den Handlauf an einer geeigneten Treppe.

- Schrauben Sie Teil G an Teil K fest.

- Markieren Sie die Bohrlöcher auf der Treppe, indem Sie die vier Bohrlöcher von Teil A nachzeichnen.

- Lassen Sie den Handlauf unverändert und bohren Sie gemäß der Markierung mit einem 12-mm-Bohrer. Richten Sie den Handlauf und die Bohrlöcher aus und schlagen Sie die Nägel (Teil M) mit einem Hammer in den Boden (bei Zement- und Marmorböden verwenden Sie bitte Teil N, bei Holzböden verwenden Sie bitte Teil M).

- Nach Abschluss der Montage J zum Schutz an beiden Enden von G anbringen.+

IT_ - Posizionare il corrimano su scale adeguate

- Avvitare la parte G alla parte K

- Segnare i punti dei fori sulle scale tracciando quattro fori della parte A

- Lasciare il corrimano e forare in base al segno con un trapano da 12 mm Allineare il corrimano e i fori, piantare i chiodi (parte M) nel terreno con un martello (per pavimenti in cemento e marmo, utilizzare la parte N; per pavimenti in legno, utilizzare la parte M)

- Una volta completato il montaggio, posizionare la parte J su entrambe le estremità della parte G per proteggerle.

RO_ -Așezați balustrada pe scările potrivite

- Înșurubați piesa G de piesa K

- Marcați locurile pentru găuri pe scări, urmărind cele patru găuri ale piesei A

- Lăsați balustrada așa cum este și găuriți conform marcajelor cu un burghiu de 12 mm. Aliniați balustrada cu găurile, apoi bateți cuiele (piesa M) în podea cu un ciocan (pentru pardoseli din ciment și marmură, vă rugăm să folosiți piesa N; pentru pardoseli din lemn, vă rugăm să folosiți piesa M)

- După finalizarea asamblării, puneți piesa J la ambele capete ale piesei G pentru protecție.

EN_ Need an electric drill to drill 12mm hole

FR_ Besoin d'une perceuse électrique pour percer un trou de 12 mm

ES_ Necesito un taladro eléctrico para hacer un agujero de 12 mm.

PT_ Precisa de uma furadeira elétrica para fazer um furo de 12 mm

DE_ Benötigen Sie eine Bohrmaschine, um ein 12-mm-Loch zu bohren?

IT_ È necessario un trapano elettrico per praticare un foro da 12 mm.

RO_ Am nevoie de o mașină de găurit electrică pentru a face o gaură de 12 mm

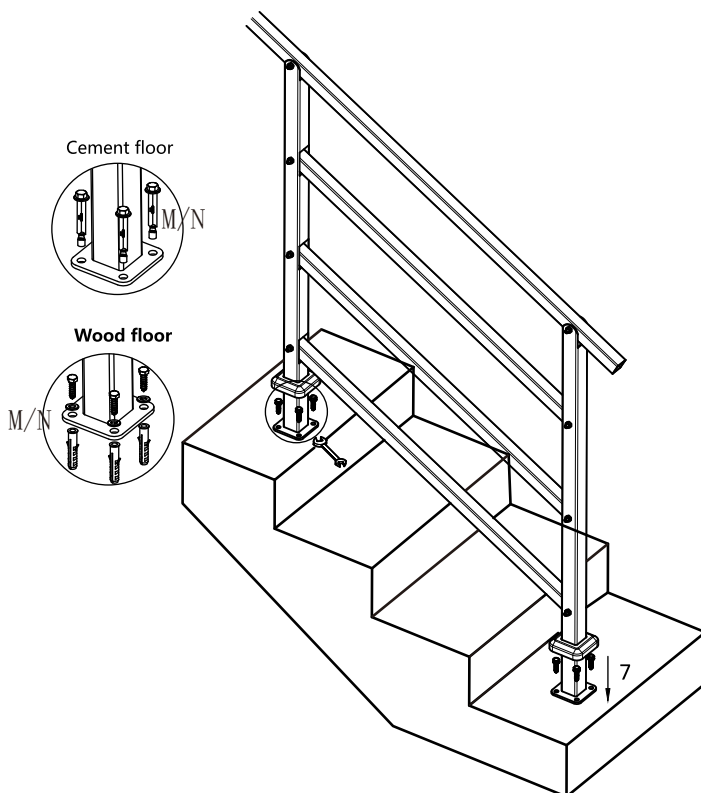

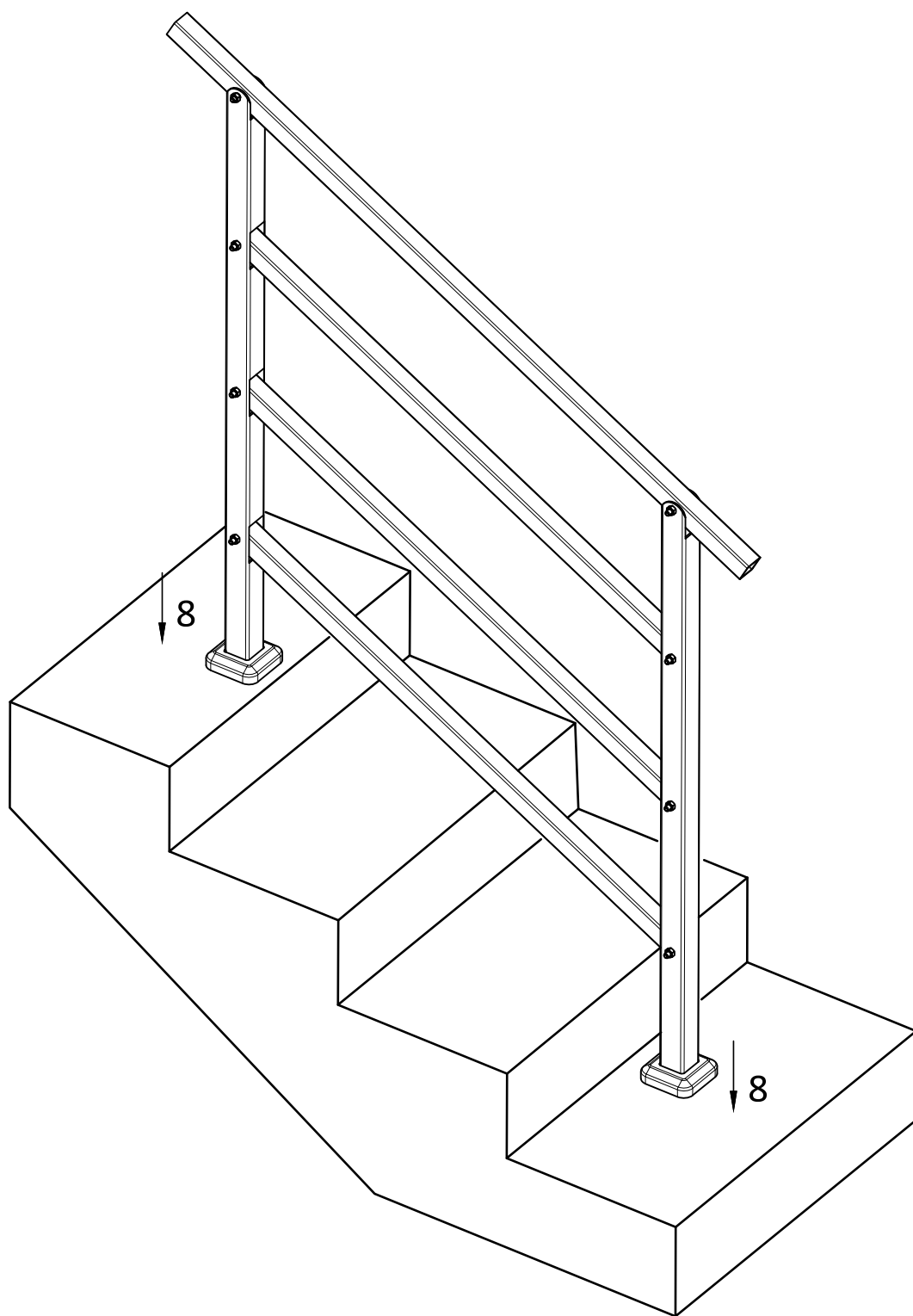

If you have any questions, please contact our customer care center, Our contact details are below:

US

 001-877-644-9366

 customerservice@aosom.com

Imported by Aosom LLC
7777 Center Ave. Suite 430
Huntington Beach, CA 92647-9998 USA
MADE IN CHINA

If you have any questions, please contact our customer care center, Our contact details are below:

UK

 0044-800-240-4004

 enquiries@mhstar.co.uk

IMPORTER ADDRESS:
MH STAR UK Ltd
1 Northampton Cross Logistics Park
Northampton Cross Road
Northampton
NN4 9FH
MADE IN CHINA

If you have any questions, please contact our customer care center, Our contact details are below:

CA

 416-792-6088

 customerservice@aosom.ca

Imported by Aosom Canada Inc.
7270 Woodbine Avenue, Unit 307, Markham,
Ontario Canada L3R 4B9
MADE IN CHINA

Si vous avez la moindre question, veuillez contacter notre centre d'assistance à la clientèle, Nos coordonnées sont les suivantes:

 416-792-6088

 customerservice@aosom.ca

Importé par Aosom Canada Inc.
7270 Woodbine Avenue, unité 307,
Markham, Ontario Canada L3R 4B9
FABRIQUÉ EN CHINE

Wenn Sie Fragen haben, wenden Sie sich bitte an unser Kundendienstzentrum, Unsere Kontaktdaten stehen unten:

DE

 0049-0(40)-87408465

 service@aosom.de

ADRESSE DES IMPORTEUR/Hersteller/REP:
MH Handel GmbH
Wendenstraße 309
D-20537 Hamburg
Germany
IN CHINA HERGESTELLT

In caso di dubbio, si prega di contattare il nostro centro assistenza clienti, I nostri dettagli di contatto sono di seguito:

IT

 0039-0249471447

 clienti@aosom.it

IMPORTATO DA/Produttore/REP:
AOSOM Italy srl
Centro Direzionale Milanofiori
Strada 1 Palazzo F1
20057 Assago (MI)
P.I.: 08567220960
FATTO IN CINA

Si tiene alguna pregunta, comuníquese con nuestro Centro de Atención al Cliente, Nuestros datos de contacto son los siguientes:

ES

 0034-931294512

 atencioncliente@aosom.es

IMPORTADOR/Fabricante/REP:
SPANISH AOSOM, S.L.
C/ROC GROS, Nº15.08550, ELS HOSTALET DE
BALENYÀ, SPAIN.
B66295775
HECHO EN CHINA

Se tiver alguma dúvida, por favor contacte o nosso Centro de Atendimento ao Cliente, Os nossos dados de contacto são os seguintes:

 0034-931294512

 info@aosom.pt.

Dacă aveți întrebări, vă rugăm să contactați serviciul nostru clienți. Datele de contact sunt mai jos.

RO

 +40 312294730

 Clienti@aosom.ro

Importator/Producător/REP:
Aosom Romania SRL
Str. Barbu Mumuleanu, nr. 30-32
Bucuresti, Sector 2
FABRICAT IN CHINA

Si vous avez la moindre question, veuillez contacter notre centre d'assistance à la clientèle, Nos coordonnées sont les suivantes:

FR

 0033-1-84166106

 aosom@mhfrance.fr

Importé par/Fabricant/REP:
MH FRANCE
2 Rue Maurice Hartmann
92130 Issy Les Moulineaux
France
FABRIQUÉ EN CHINE



FR

**DONNEZ
OU
RECYCLEZ**



ASSOCIATION

OU



LIVRAISON

OU



DÉCHÈTERIE

Adresses sur quefairedemesdechets.fr