



IN251000263V02_GL

84H-597V00



14

STEPS



1 HR



EN_IMPORTANT, RETAIN FOR FUTURE REFERENCE: READ CAREFULLY.

FR_IMPORTANT : A LIRE ATTENTIVEMENT ET A CONSERVER POUR VOUS Y REFERER ULTERIEUREMENT

ES_IMPORTANTE, LEA Y GUARDE PARA FUTURAS REFERENCIAS.

PT_IMPORTANTE, RETAR PARA REFERÉNCIA FUTURA: LEIA ATENTAMENTE.

DE_WICHTIG! SORGFÄLTIG LESEN UND FÜR SPÄTER NACHSCHLAGEN AUFBEWAHREN.

IT_IMPORTANTE! CONSERVARE IL PRESENTE MANUALE PER FUTURO RIFERIMENTO E LEGGERLO ATTENTAMENTE.

RO_IMPORTANT, PĂSTRAȚI PENTRU REFERINȚĂ VIITOARE: CITIȚI CU ATENȚIE.

PL_WAŻNE, PRZECHOWAJ DO WYKORZYSTANIA W PRZYSZŁOŚCI: PRZECZYTAJ UWAŻNIE.

A x3

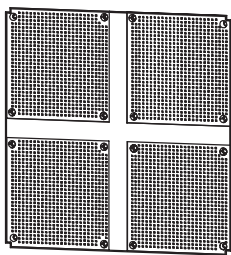

B x3

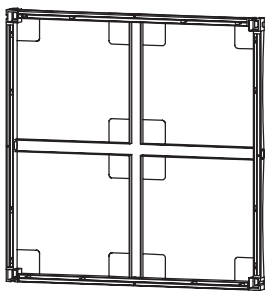

C x16

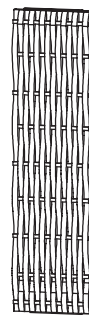

D x12



E x24



F x2



G x12



H x4

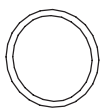

I x8

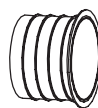

J x9

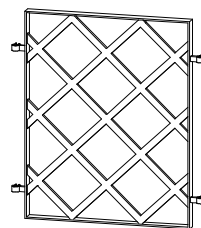

K x8



L x18

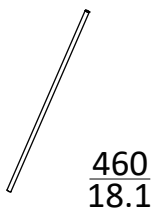

M x6

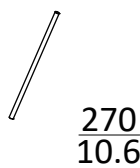

N 18



O x6



P x12

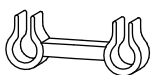

Q x4

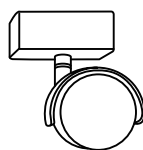

R x4

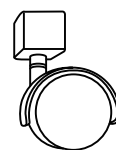

01

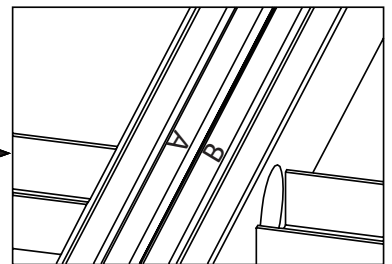
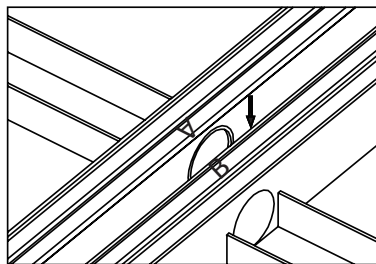
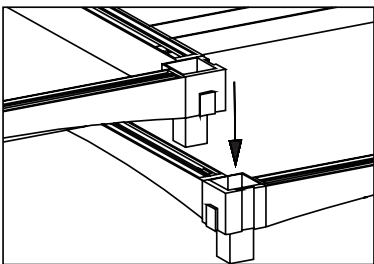
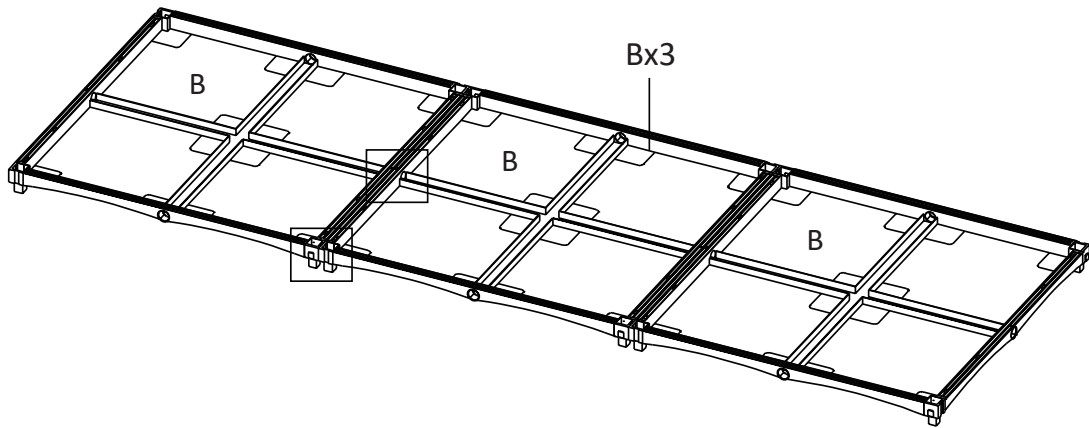

02

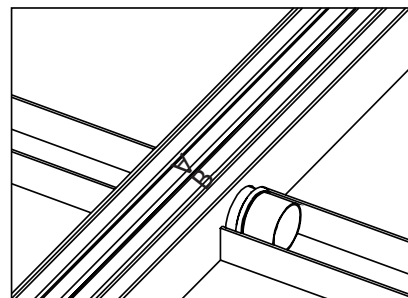
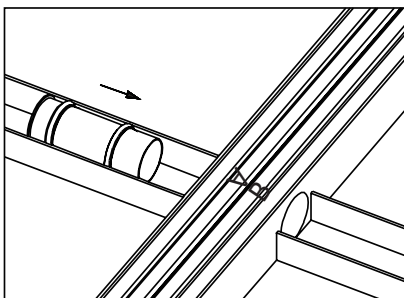
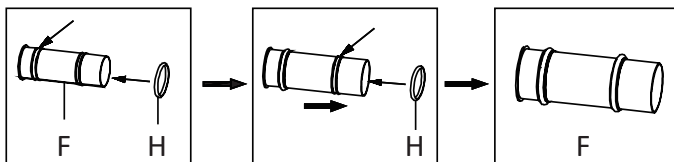
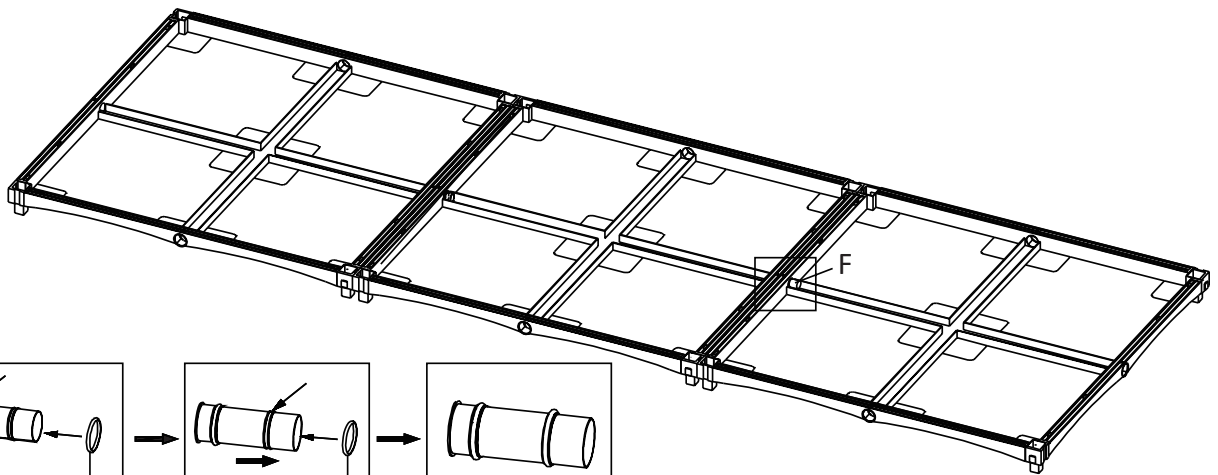

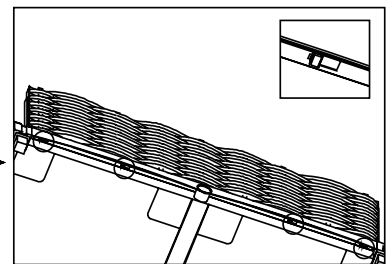
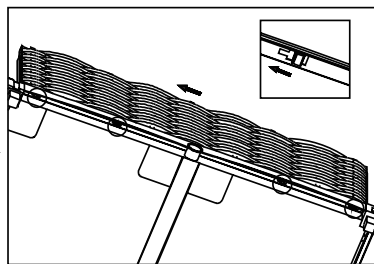
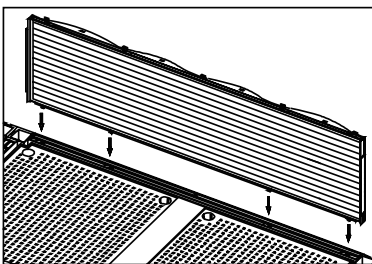
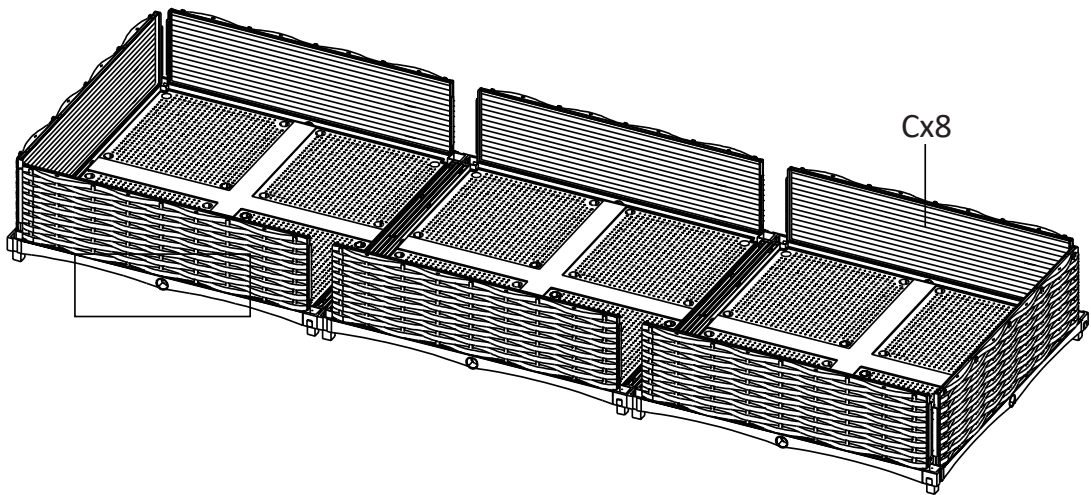
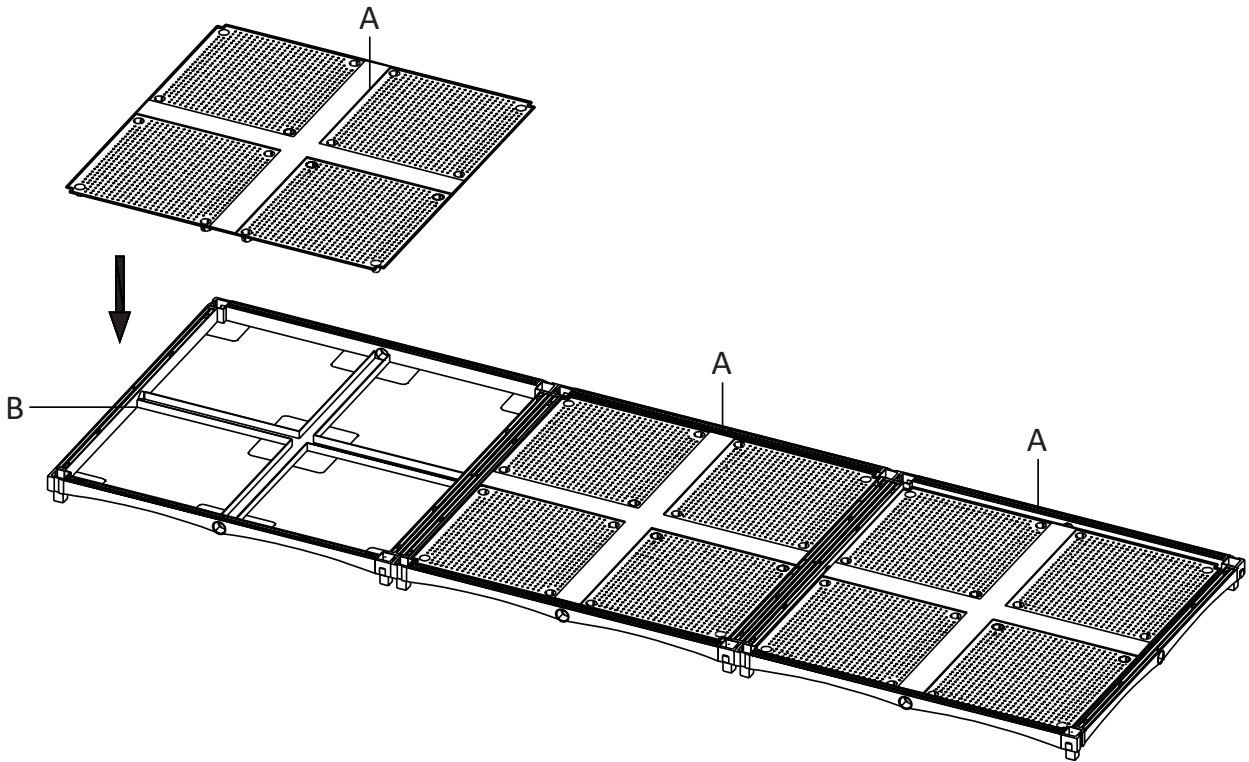

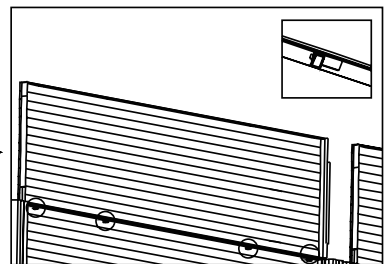
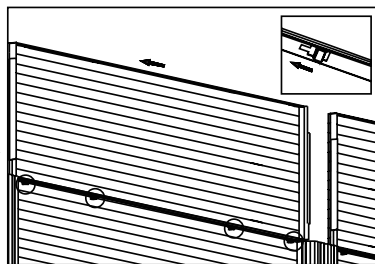
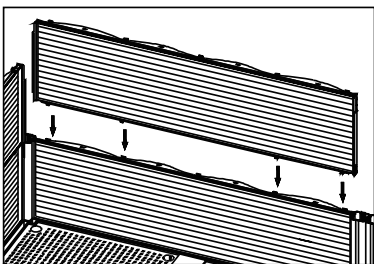
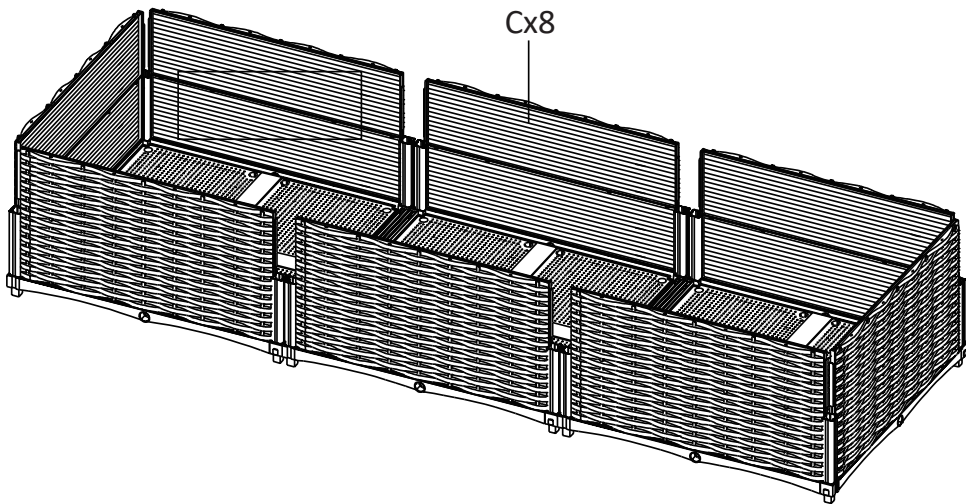
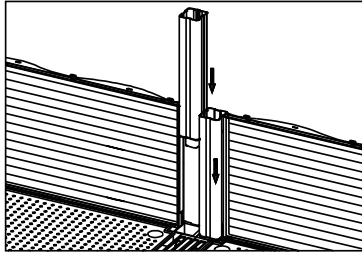
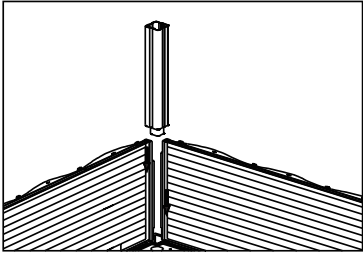
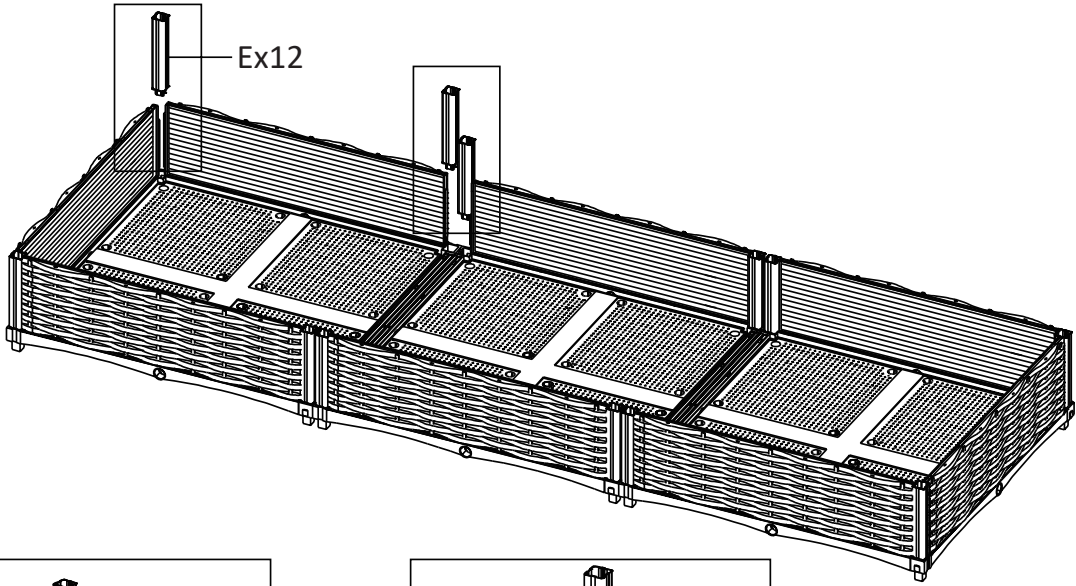

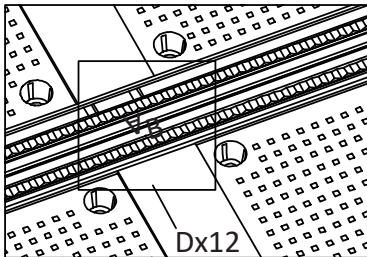
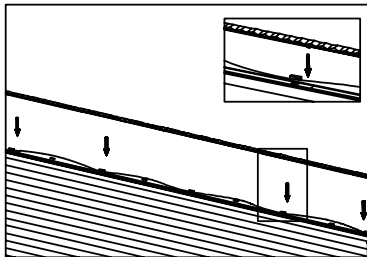
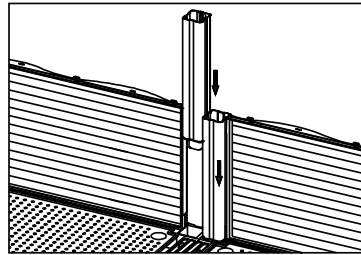
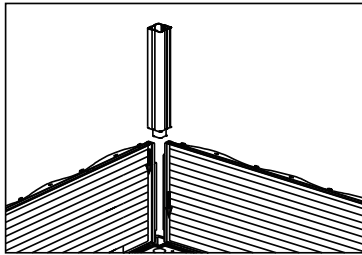
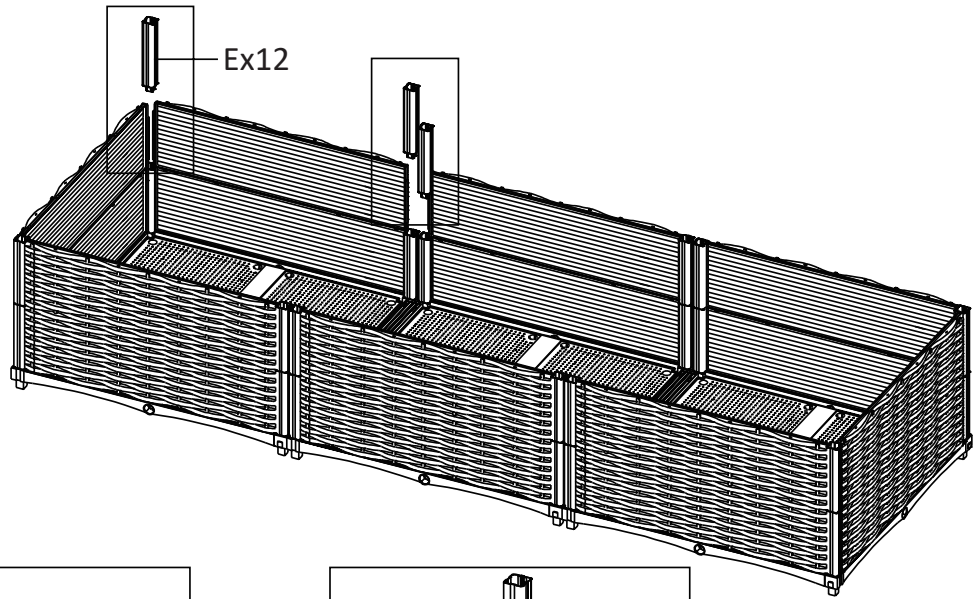

Dx12

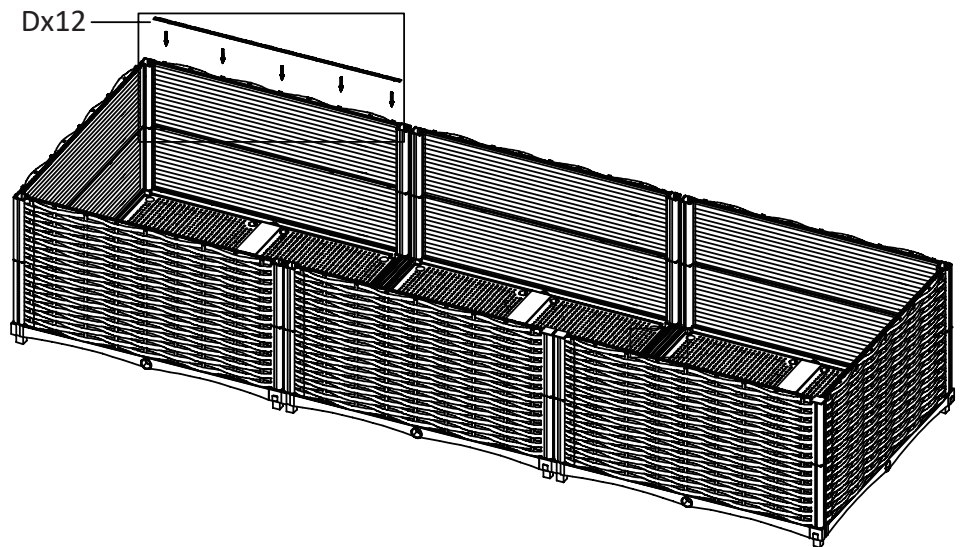

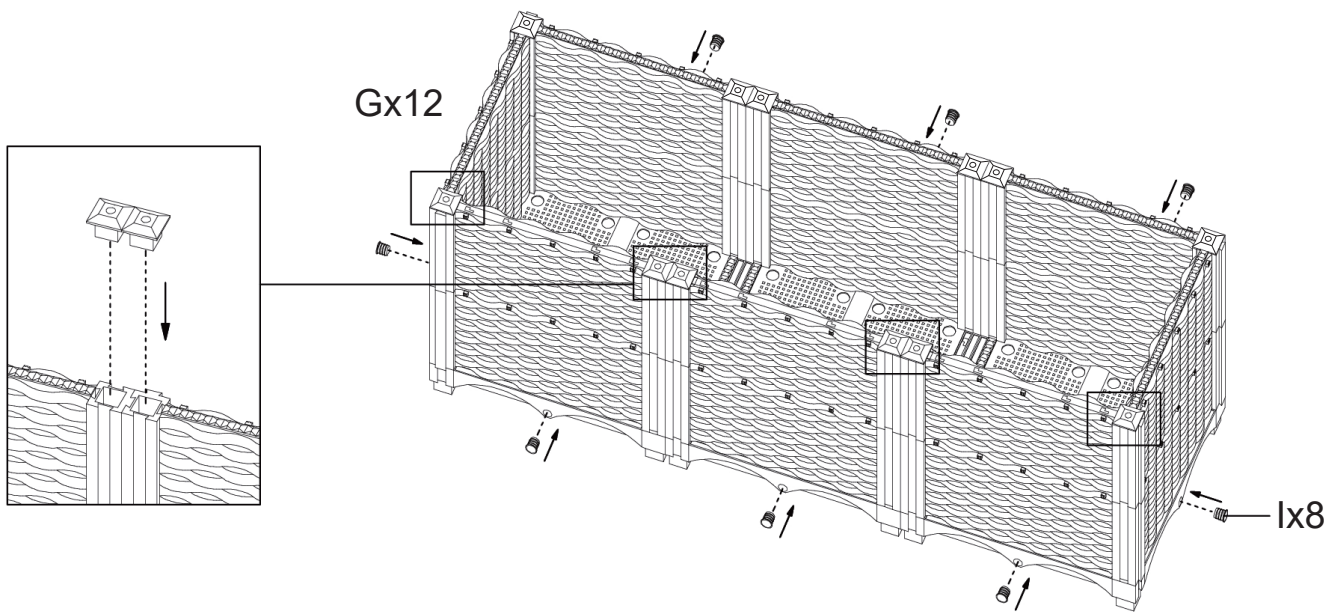
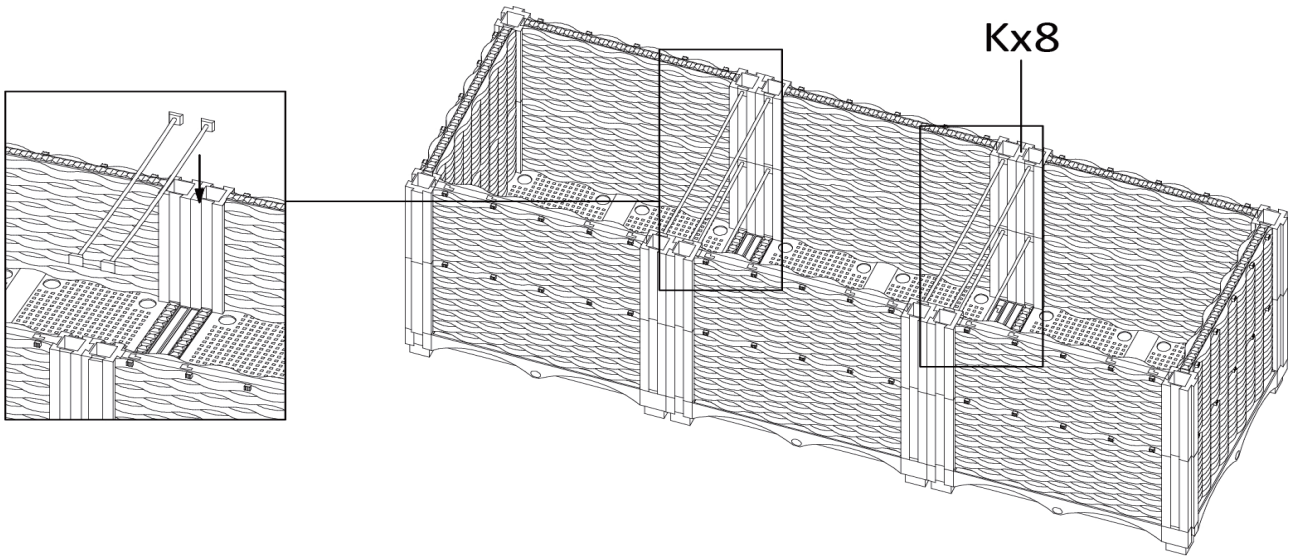

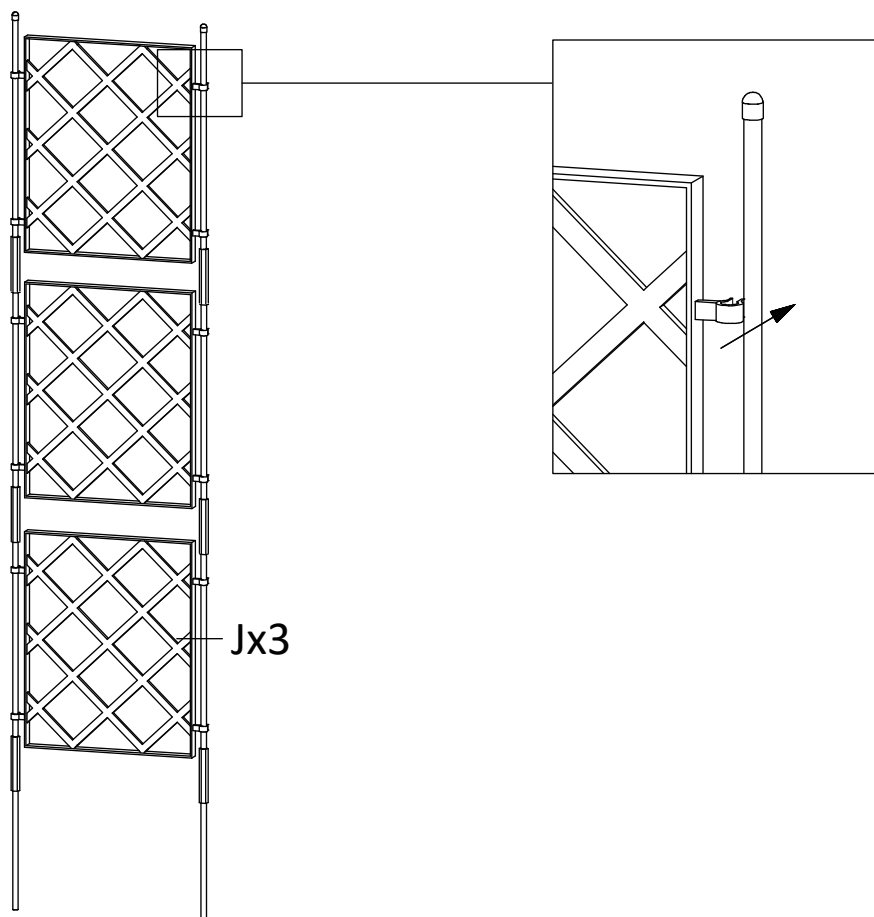
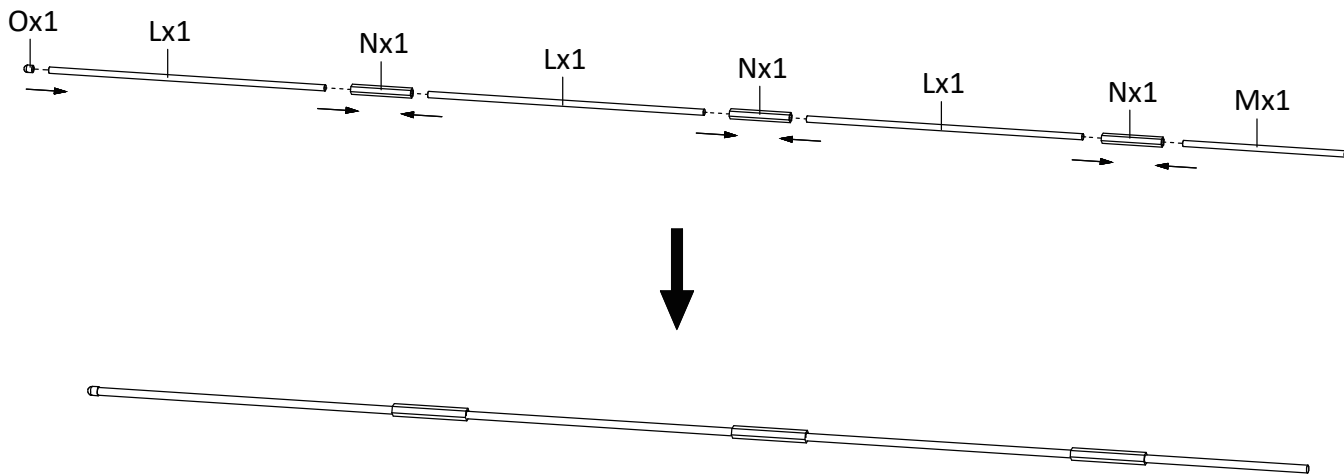

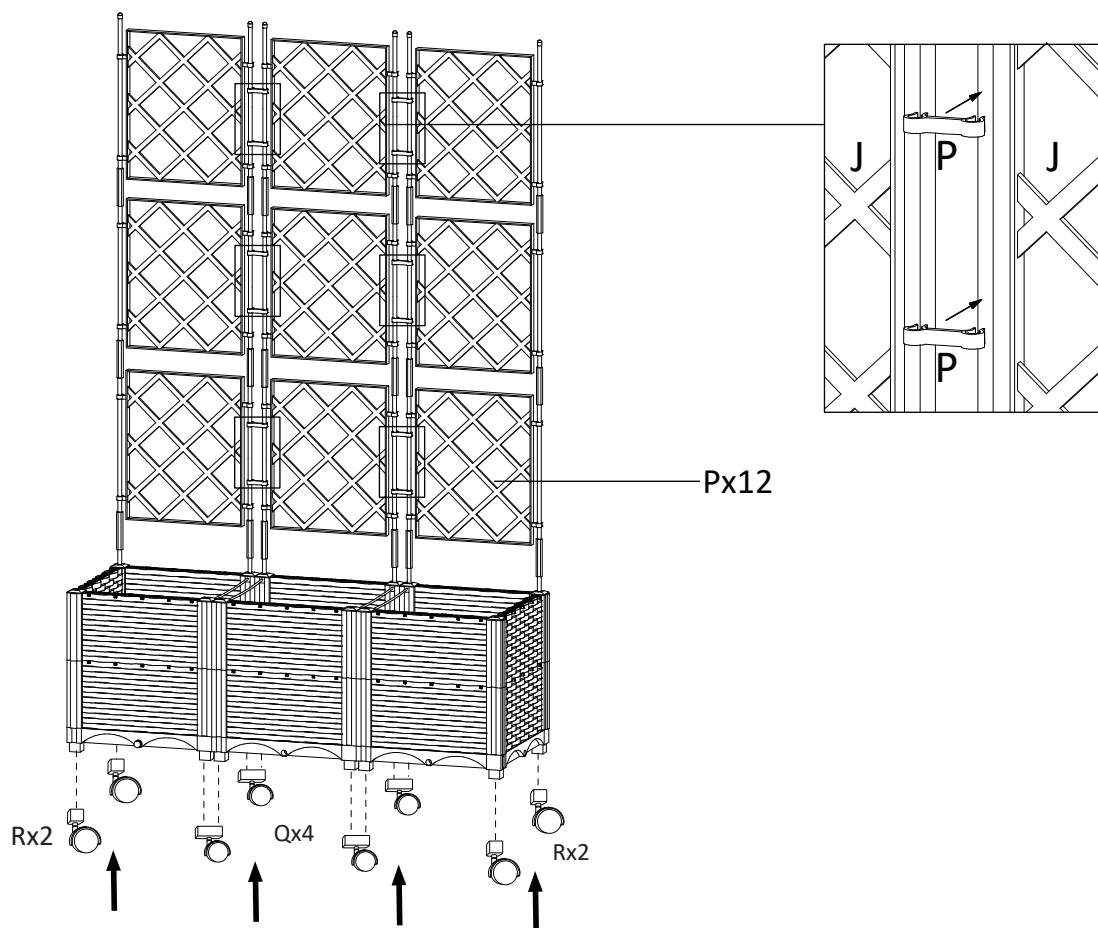
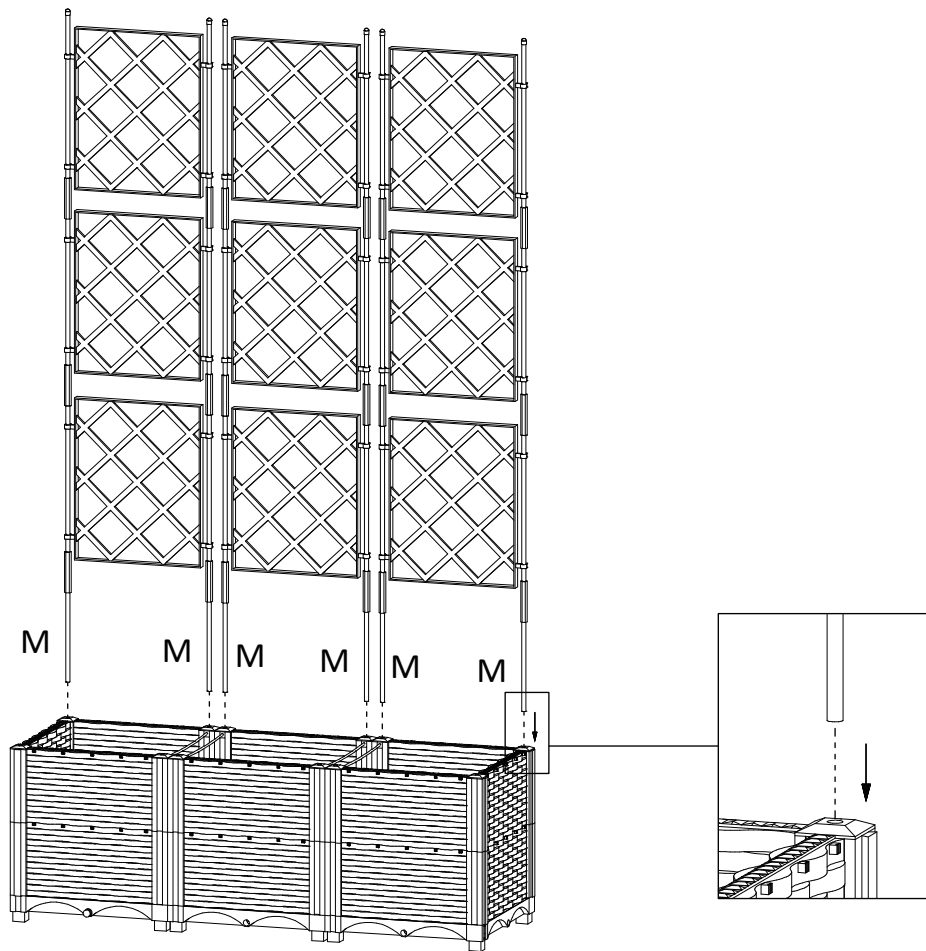

EN NOTE:

1. Place the planting box on a flat surface before installation to ensure it is level and not tilted.
2. Align the caster base with the leg interface and secure them evenly after proper alignment.
3. Tighten the fittings evenly, avoiding applying force to only one side.
4. After assembly, gently shake the box to check its stability before use.

FR REMARQUE :

1. Placez le bac à fleurs sur une surface plane avant l'installation afin de vous assurer qu'il est bien à niveau et qu'il ne penche pas.
2. Alignez la base à roulettes avec l'emboîtement des pieds et fixez-les de manière uniforme une fois l'alignement effectué.
3. Serrez les fixations de manière uniforme, en évitant d'exercer une force sur un seul côté.
4. Une fois le montage terminé, secouez doucement le bac pour vérifier sa stabilité avant de l'utiliser.

DE HINWEIS:

1. Stellen Sie den Pflanzkasten vor der Montage auf eine ebene Fläche, um sicherzustellen, dass er waagrecht steht und nicht schräg ist.
2. Richten Sie den Rollfuß auf die Befestigungsstelle am Bein aus und befestigen Sie beide Teile nach der korrekten Ausrichtung gleichmäßig.
3. Ziehen Sie die Befestigungen gleichmäßig an und vermeiden Sie es, die Kraft nur auf eine Seite auszuüben.
4. Schütteln Sie den Kasten nach der Montage vorsichtig, um seine Stabilität vor der Verwendung zu überprüfen.

ES NOTA:

1. Coloque la jardinera sobre una superficie plana antes de montarla para asegurarse de que esté nivelada y no se incline.
2. Alinee la base con ruedas con la pieza de unión de las patas y fijelas de manera uniforme una vez alineadas correctamente.
3. Apriete los tornillos de manera uniforme, evitando ejercer fuerza solo en un lado.
4. Una vez montada, agite suavemente la jardinera para comprobar su estabilidad antes de usarla.

PT NOTA:

1. Coloque a caixa de plantio sobre uma superfície plana antes da montagem, para garantir que está nivelada e não inclinada.
2. Alinhe a base com rodízios com a interface das pernas e fixe-as uniformemente após o alinhamento correto.
3. Aperte os parafusos uniformemente, evitando aplicar força apenas num dos lados.
4. Após a montagem, agite suavemente a caixa para verificar a sua estabilidade antes de a utilizar.

IT NOTA:

1. Prima dell'installazione, posizionare la fioriera su una superficie piana per assicurarsi che sia in piano e non inclinata.
2. Allineare la base delle rotelle con l'attacco delle gambe e fissarle in modo uniforme dopo averle allineate correttamente.
3. Serrare i raccordi in modo uniforme, evitando di esercitare forza su un solo lato.
4. Dopo il montaggio, scuotere delicatamente la fioriera per verificarne la stabilità prima dell'uso.

RO NOTĂ:

1. Așezați ghiveciul pe o suprafață plană înainte de montare, pentru a vă asigura că este perfect orizontal și nu este înclinat.
2. Aliniați baza cu rotile cu punctul de fixare al picioarelor și fixați-le uniform după ce le-ați aliniat corespunzător.
3. Strângeți elementele de fixare în mod uniform, evitând să aplicați forță doar pe o singură parte.
4. După asamblare, scuturați ușor ghiveciul pentru a verifica stabilitatea acestuia înainte de utilizare.

PL UWAGA:

1. Przed montażem należy ustawić skrzynkę na płaskiej powierzchni, aby upewnić się, że jest wypoziomowana i nie jest przechylona.
2. Wyrównać podstawę kółek z mocowaniem nóg i po odpowiednim wyrównaniu zamocować je równomiernie.
3. Dokręcać elementy mocujące równomiernie, unikając wywierania nacisku tylko na jedną stronę.
4. Po złożeniu delikatnie potrząsnąć skrzynką, aby przed użyciem sprawdzić jej stabilność.

If you have any questions, please contact our customer care center, Our contact details are below:

US

 001-877-644-9366

 customerservice@aosom.com

Imported by Aosom LLC
7777 Center Ave. Suite 430
Huntington Beach, CA 92647-9998 USA
MADE IN CHINA

If you have any questions, please contact our customer care center, Our contact details are below:

UK

 0044-800-240-4004

 enquiries@mhstar.co.uk

IMPORTER ADDRESS:
MH STAR UK LTD
1 Northampton Cross Logistics Park
Northampton Cross Road
Northampton
Nn4 9FH
Tel: 0800 240 4050
enquiries@mhstar.co.uk
MADE IN CHINA

If you have any questions, please contact our customer care center, Our contact details are below:

CA

 416-792-6088

 customerservice@aosom.ca

Imported by Aosom Canada Inc.
Unit 33-1 Sparks Avenue, North York, Ontario,
Canada
M2H 2W1
MADE IN CHINA

Si vous avez la moindre question, veuillez contacter notre centre d'assistance à la clientèle, Nos coordonnées sont les suivantes:

 416-792-6088

 customerservice@aosom.ca

Importé par Aosom Canada Inc.
Unité 33-1 Sparks Avenue, North York, Ontario,
Canada M2H 2W1
Fabriqué en Chine

Wenn Sie Fragen haben, wenden Sie sich bitte an unser Kundendienstzentrum, Unsere Kontaktdaten stehen unten:

DE

 0049-0(40)-87408465

 service@aosom.de

ADRESSE DES IMPORTEURE/Hersteller/REP:
MH Handel GmbH
Wendenstraße 309
D-20537 Hamburg
Germany
IN CHINA HERGESTELLT

In caso di dubbio, si prega di contattare il nostro centro assistenza clienti, I nostri dettagli di contatto sono di seguito:

IT

 0039-0249471447

 clienti@aosom.it

IMPORTATO DA/Produttore/REP:
AOSOM Italy srl
Centro Direzionale Milanofiori
Strada 1 Palazzo F1
20057 Assago (MI)
P.I.: 08567220960
FATTO IN CINA

Si tiene alguna pregunta, comuníquese con nuestro Centro de Atención al Cliente, Nuestros datos de contacto son los siguientes:

ES

 0034-931294512

 atencioncliente@aosom.es

IMPORTADOR/Fabricante/REP:
SPANISH AOSOM, S.L.
C/ROC GROS, Nº15.08550, ELS HOSTALET DE
BALENYÀ, SPAIN.
B66295775
HECHO EN CHINA

Se tiver alguma dúvida, por favor contacte o nosso Centro de Atendimento ao Cliente, Os nossos dados de contacto são os seguintes:

 0034-931294512

 info@aosom.pt.

Importator/Producător/REP:

RO

Aosom Romania SRL
Str. Barbu Mumuleanu, nr. 30-32
Bucuresti, Sector 2
Tel: +40 312294730
clienti@aosom.ro
Fabricat in China

Si vous avez la moindre question, veuillez contacter notre centre d'assistance à la clientèle, Nos coordonnées sont les suivantes:

FR

 0033-1-84166106

 aosom@mhfrance.fr

Importé par/Fabricant/REP:
MH FRANCE
2 Rue Maurice Hartmann
92130 Issy Les Moulineaux
France
FABRIQUÉ EN CHINE



FR

**DONNEZ
OU
RECYCLEZ**



ASSOCIATION

OU



LIVRAISON

OU



DÉCHÈTERIE

Adresses sur quefairedemesdechets.fr