

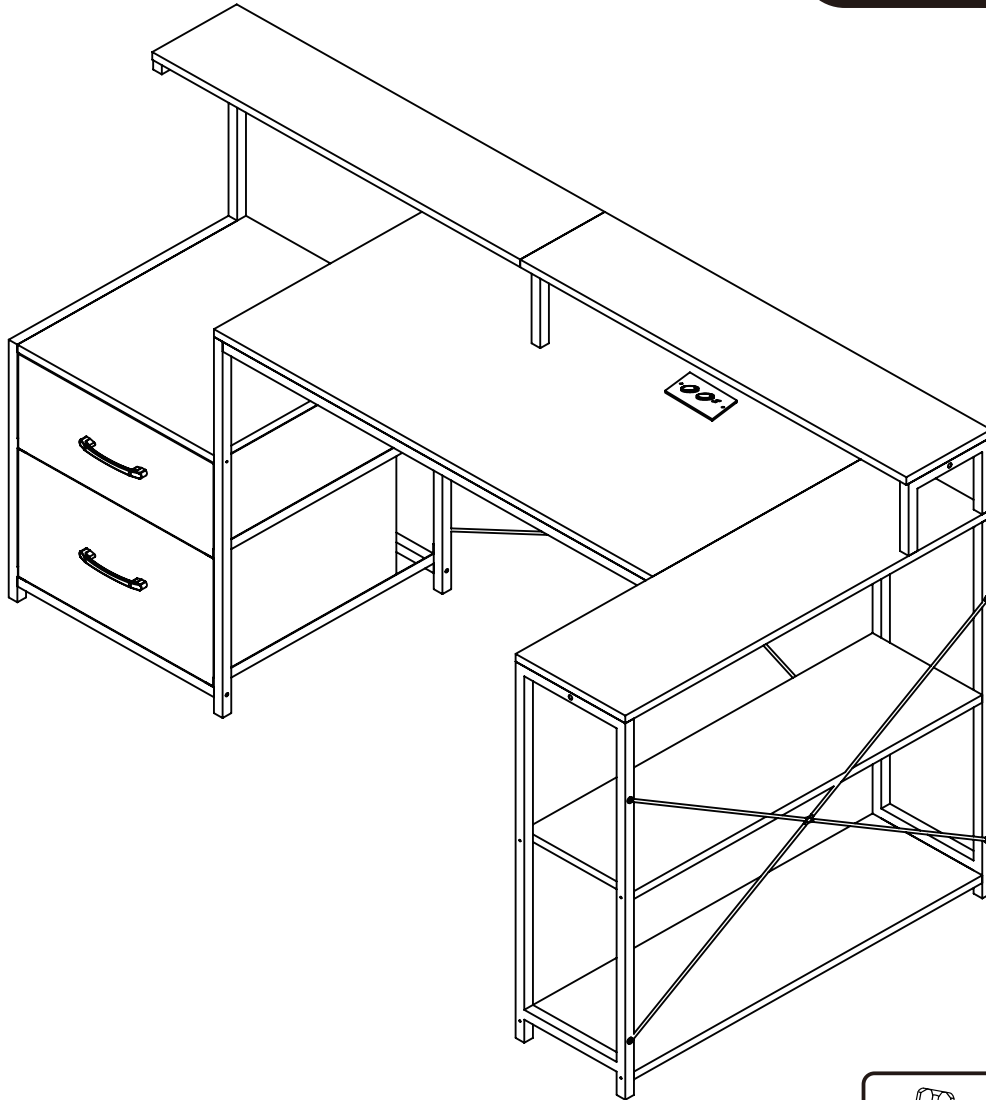

IN250900285V01

836-677V90



15
STEPS

1.5 HR

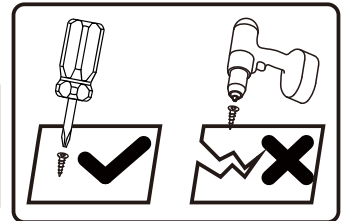
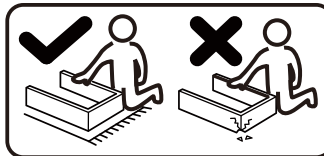
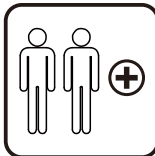

Tools Recommended

EN_ IMPORTANT, RETAIN FOR FUTURE REFERENCE: READ CAREFULLY.

FR_ IMPORTANT: A LIRE ATTENTIVEMENT ET À CONSERVER POUR CONSULTATION ULTÉRIEURE.

ES_ IMPORTANTE, LEA Y GUARDE PARA FUTURAS REFERENCIAS.

PT_ IMPORTANTE: LEIA ATENTAMENTE E GUARDE PARA CONSULTA FUTURA.

DE_ WICHTIG! SORGFÄLTIG LESEN UND FÜR SPÄTER NACHSCHLAGEN AUFBEWAHREN.

IT_ IMPORTANTE! CONSERVARE IL PRESENTE MANUALE PER FUTURO RIFERIMENTO E LEGGERLO ATTENTAMENTE.

RO_ IMPORTANT: CITIȚI CU ATENȚIE ȘI PĂSTRAȚI PENTRU CONSULTARE VIITOARE.

PARTS

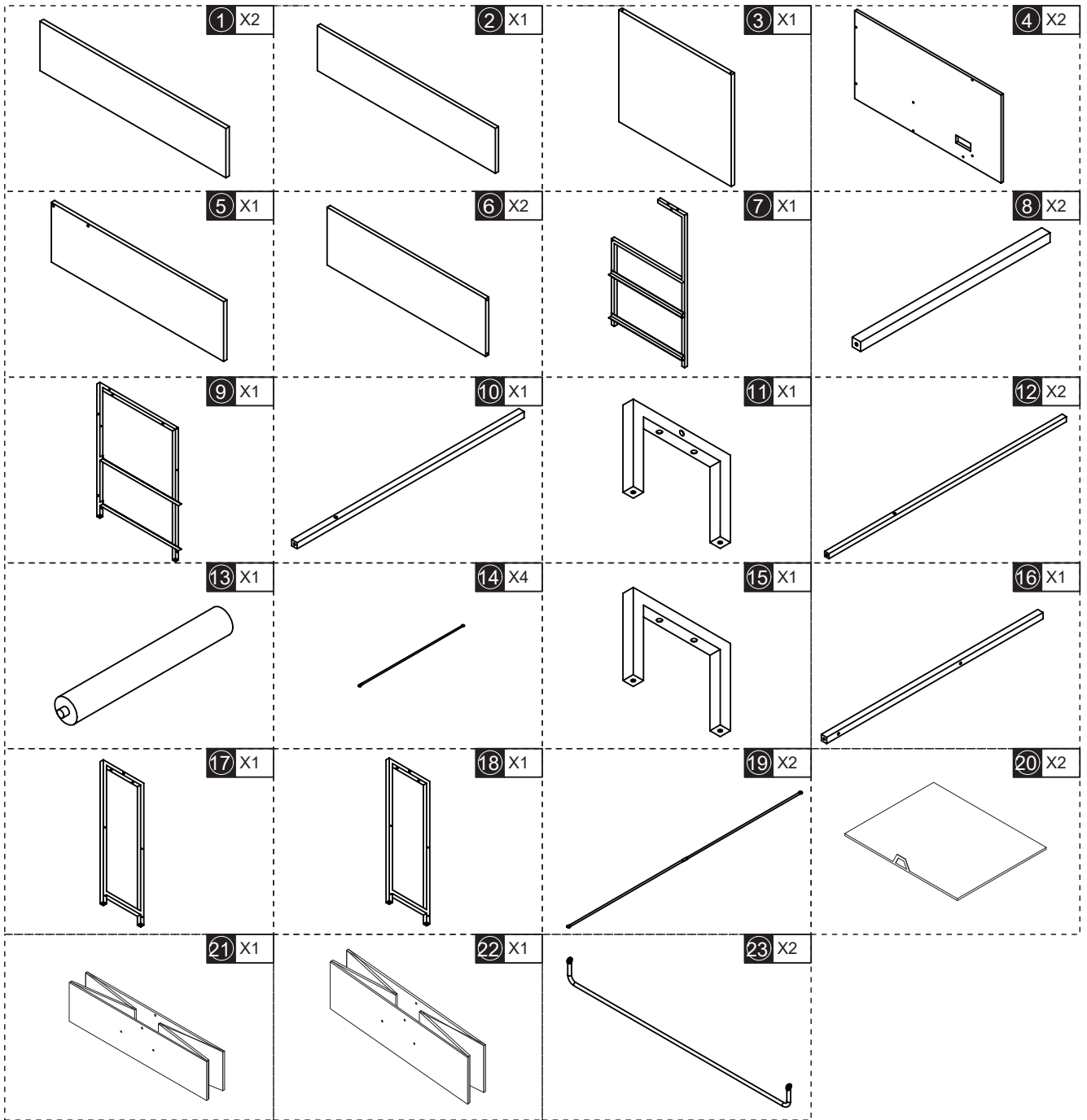

HARDWARE

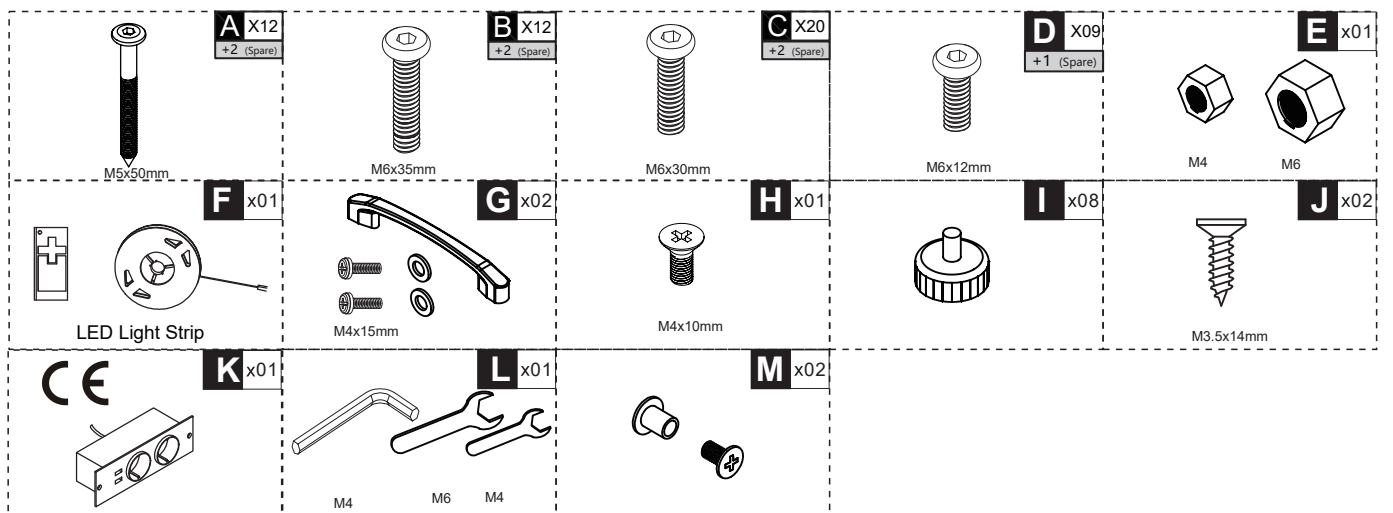

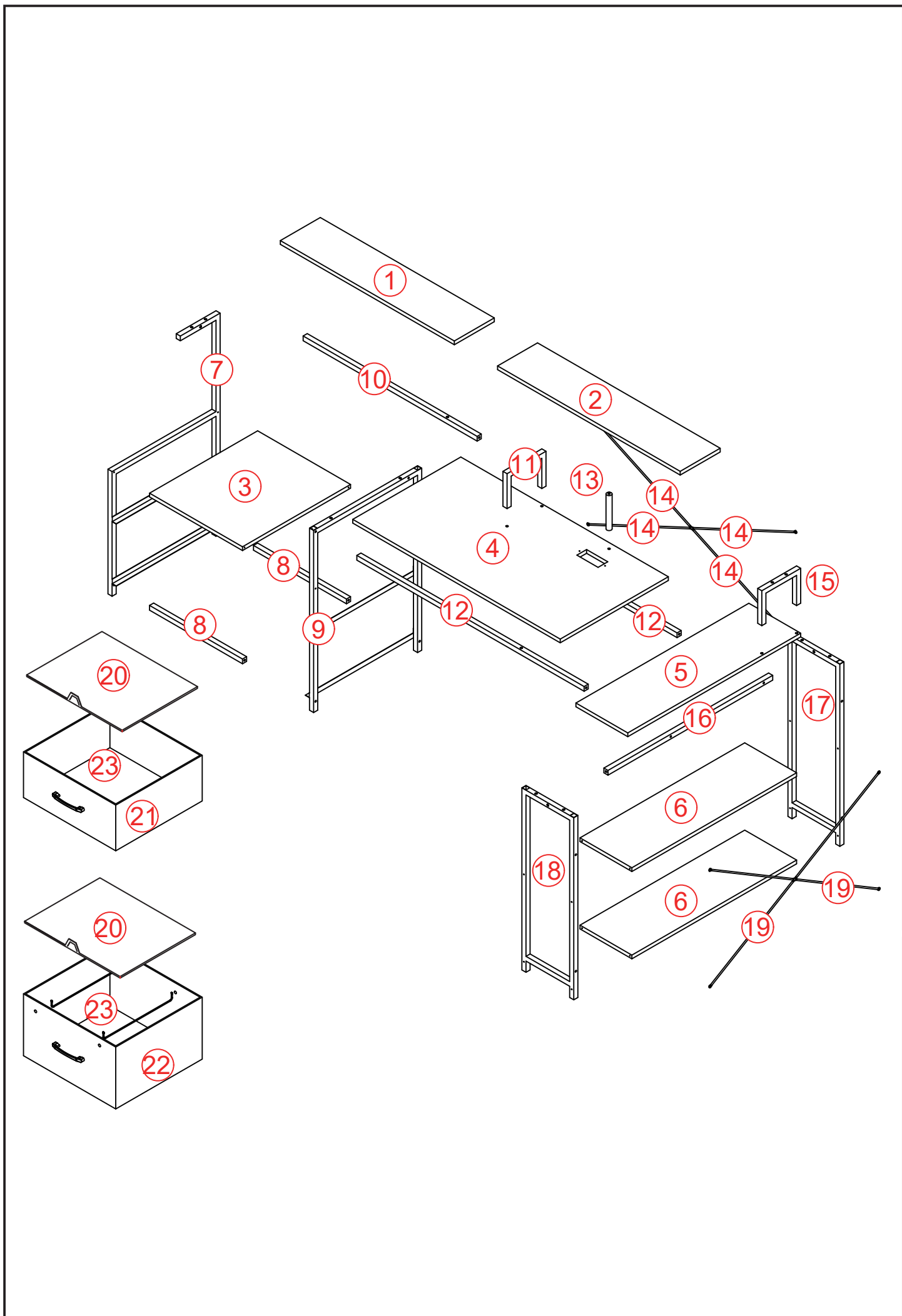

A X8

B X2

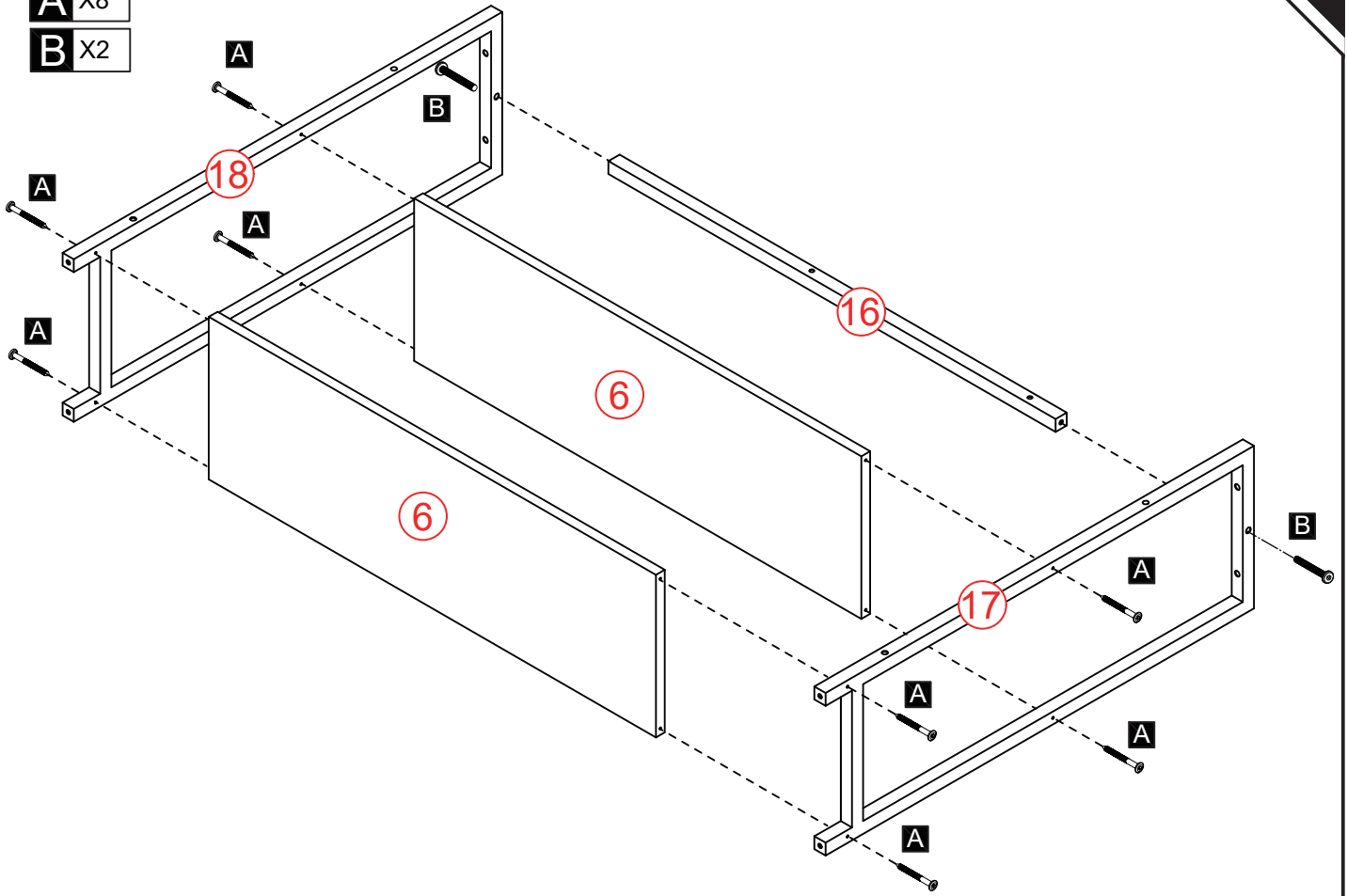

D X4

H X1

E X1

I X4

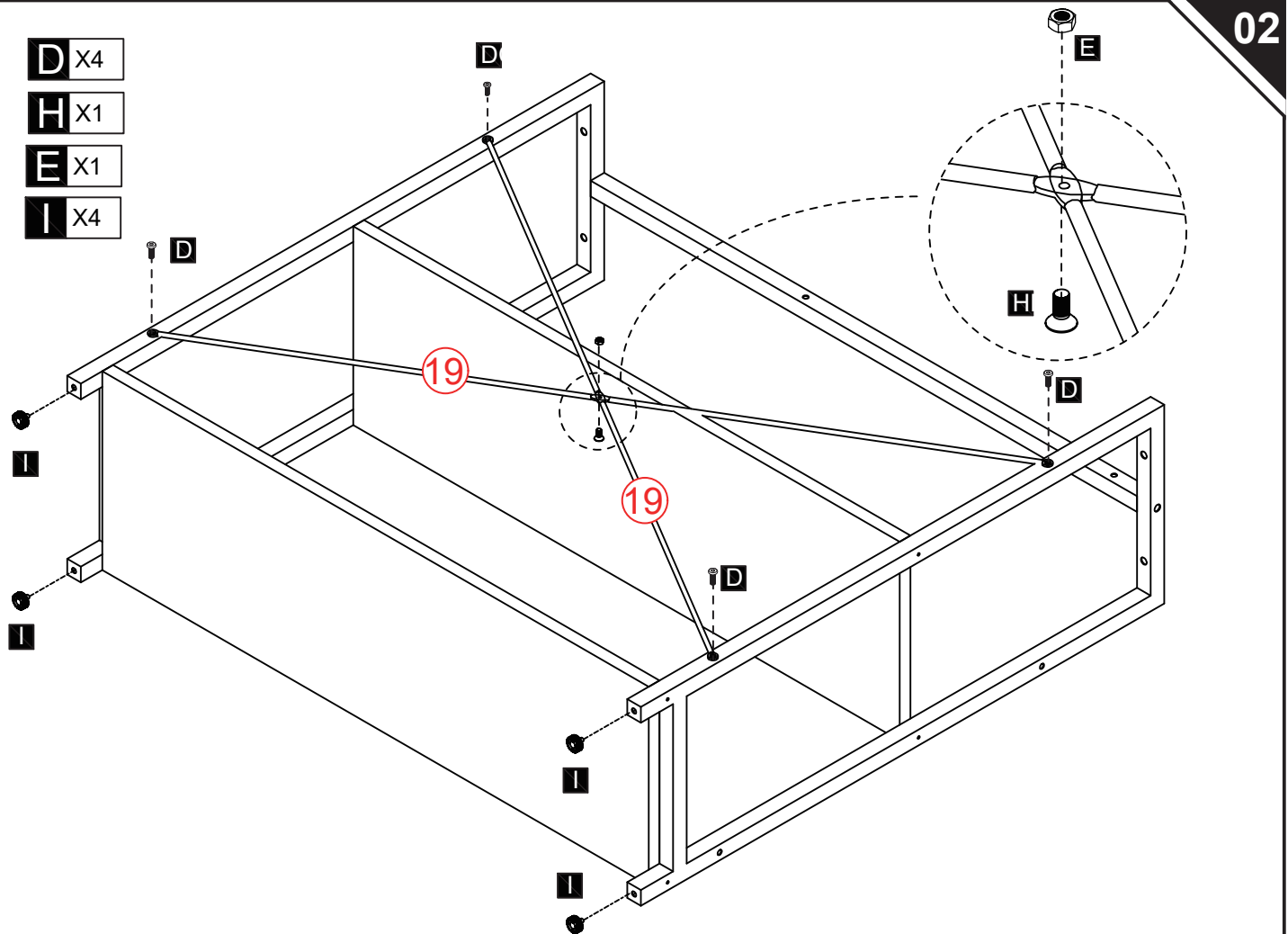

C X2

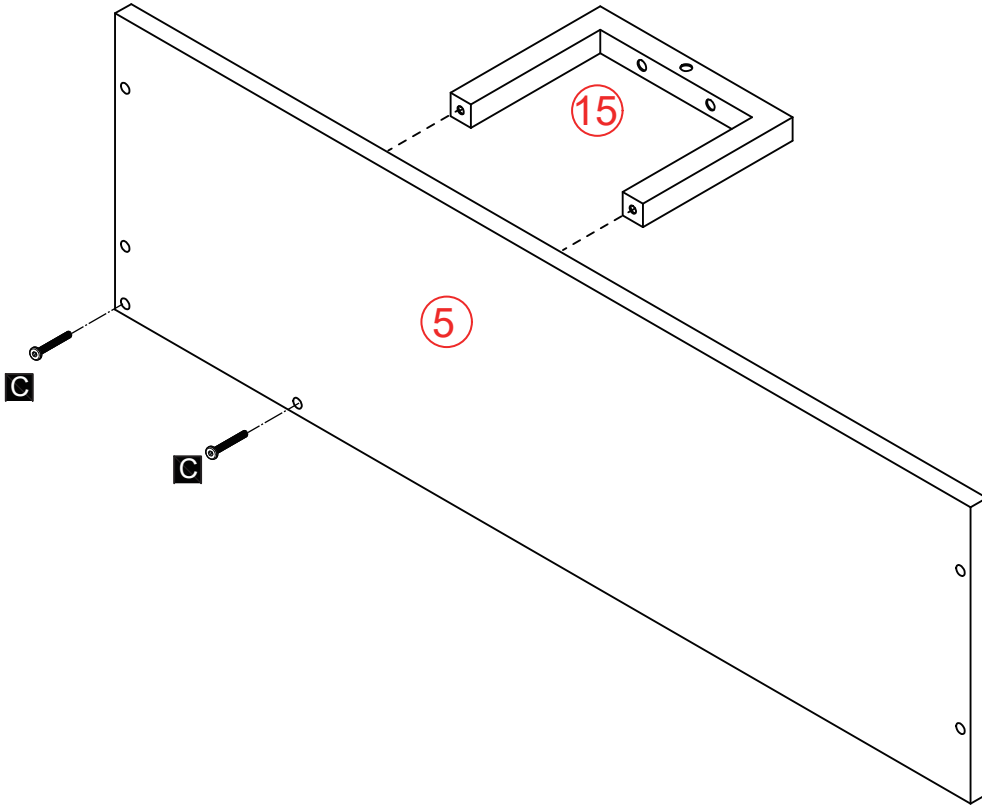

C X2

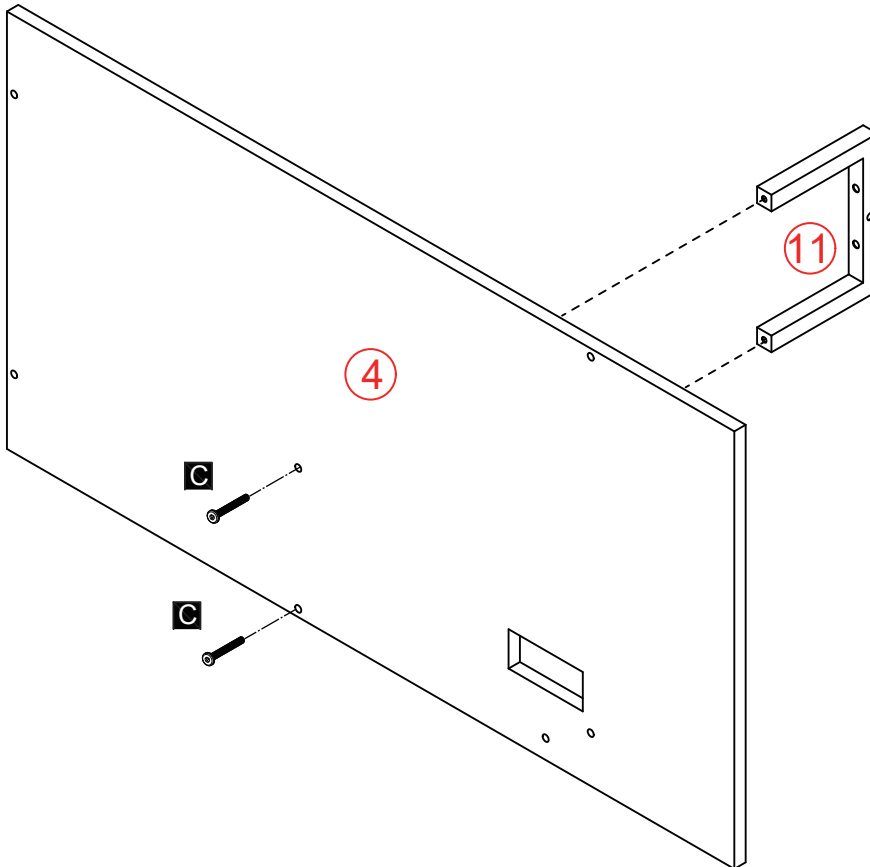

A X4

B X4

I X4

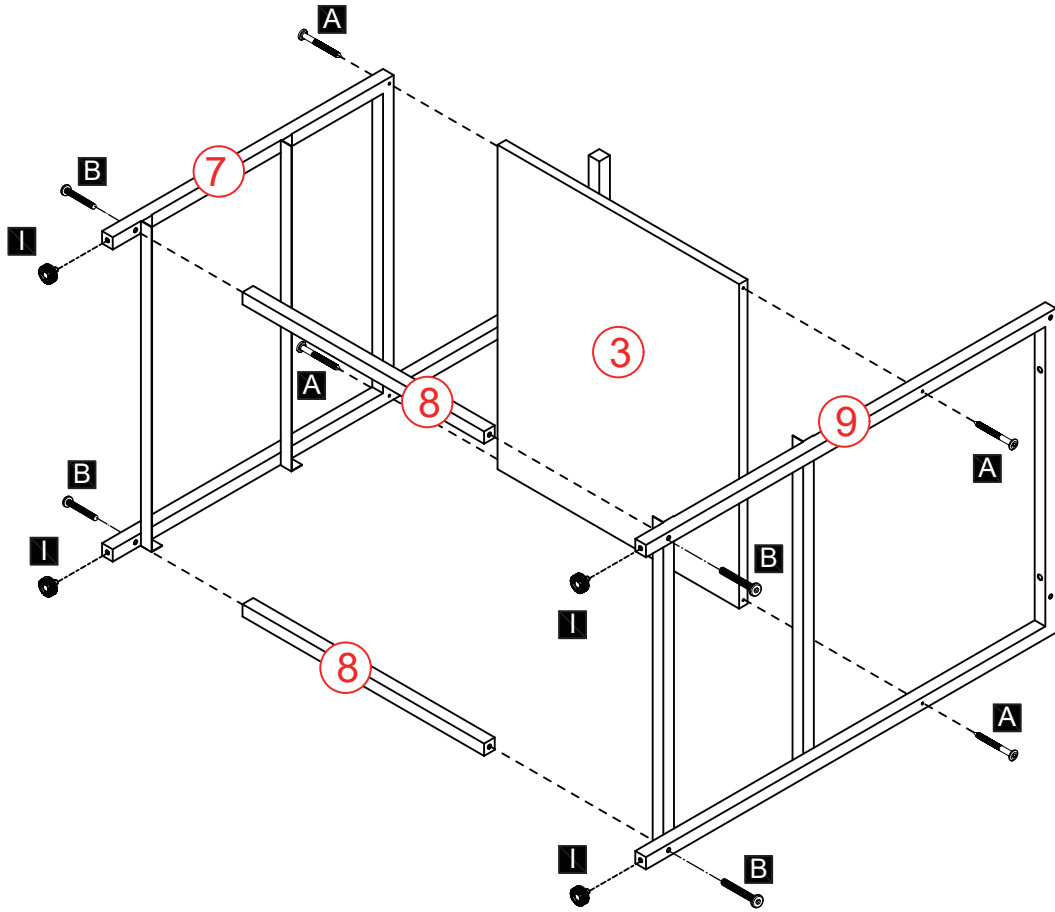

B X4

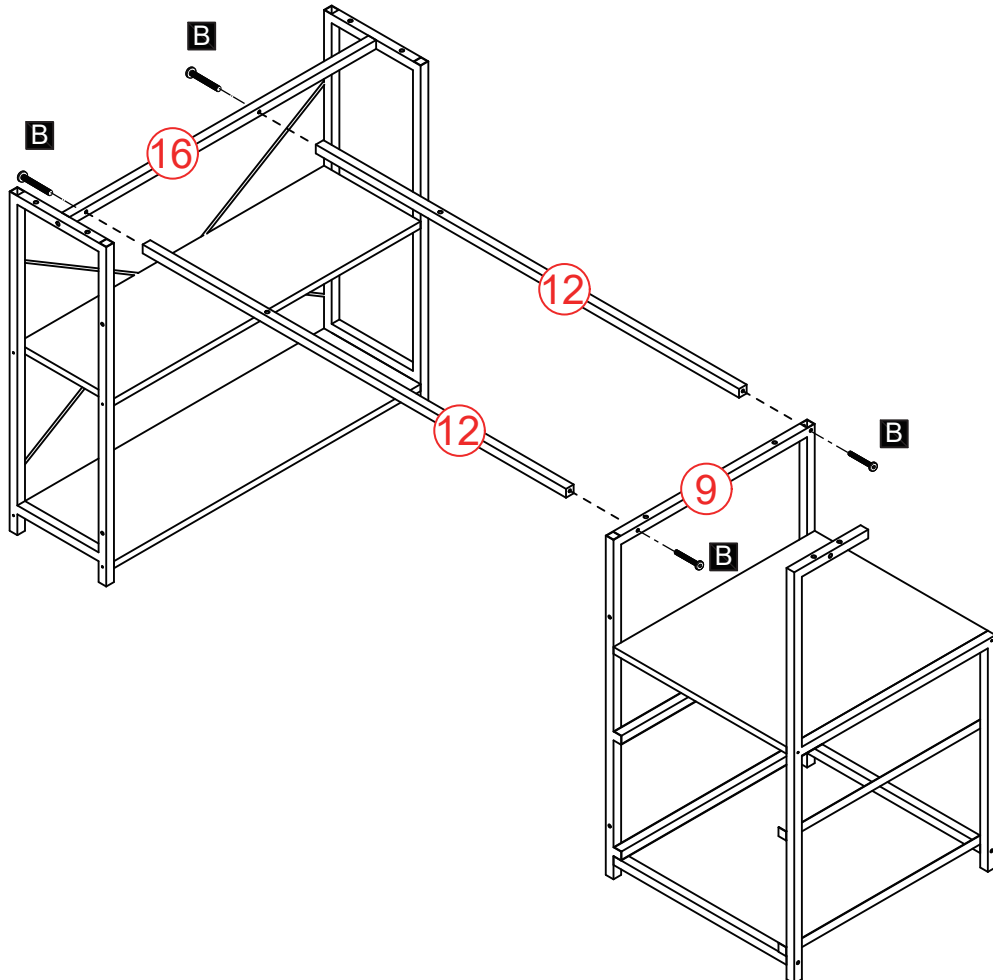

D X5
F X1

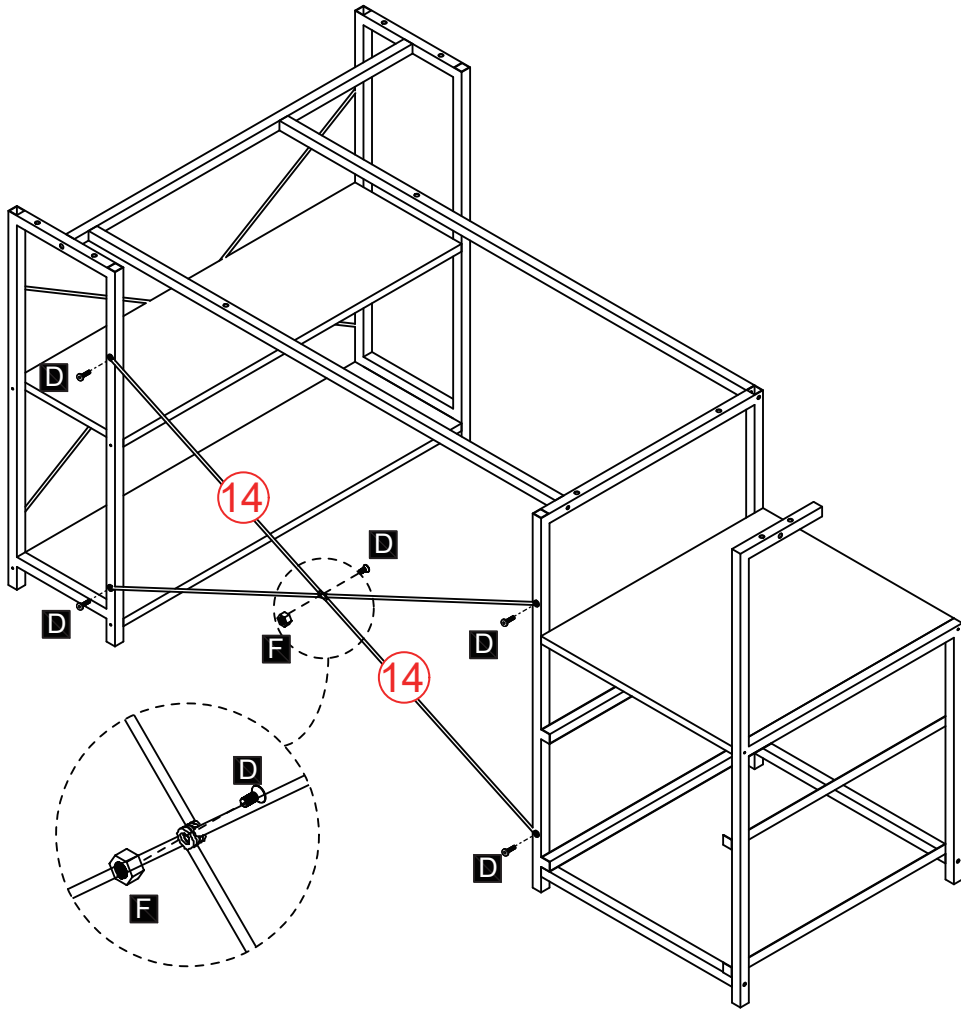

C X8

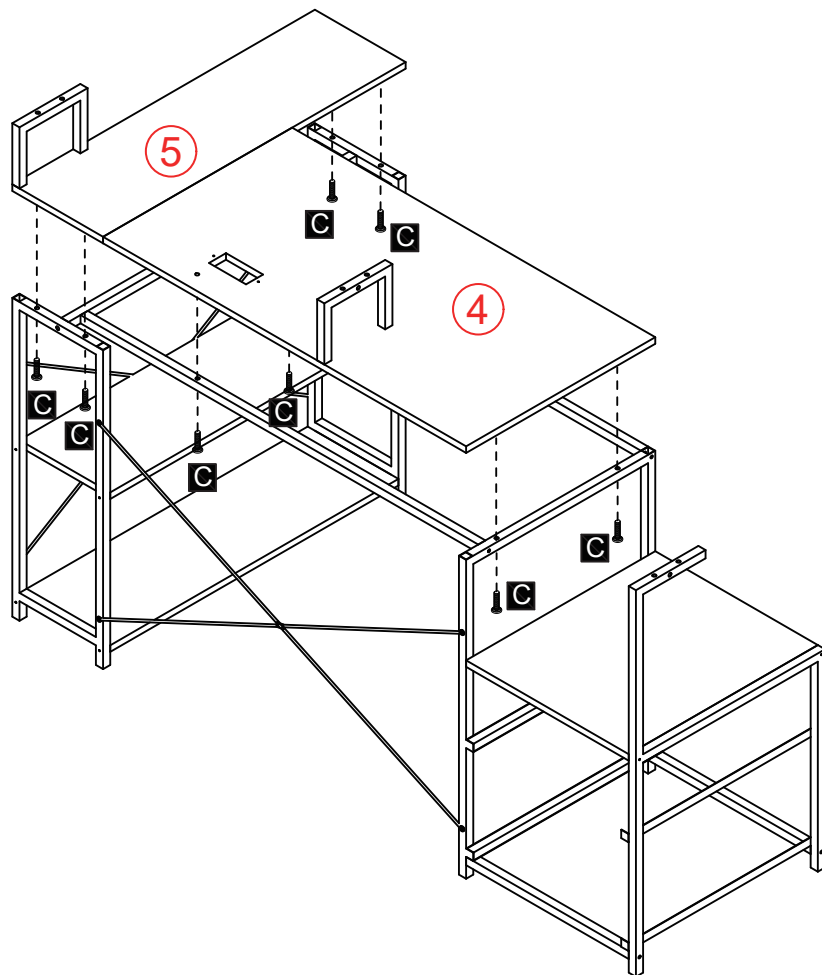

B X 2

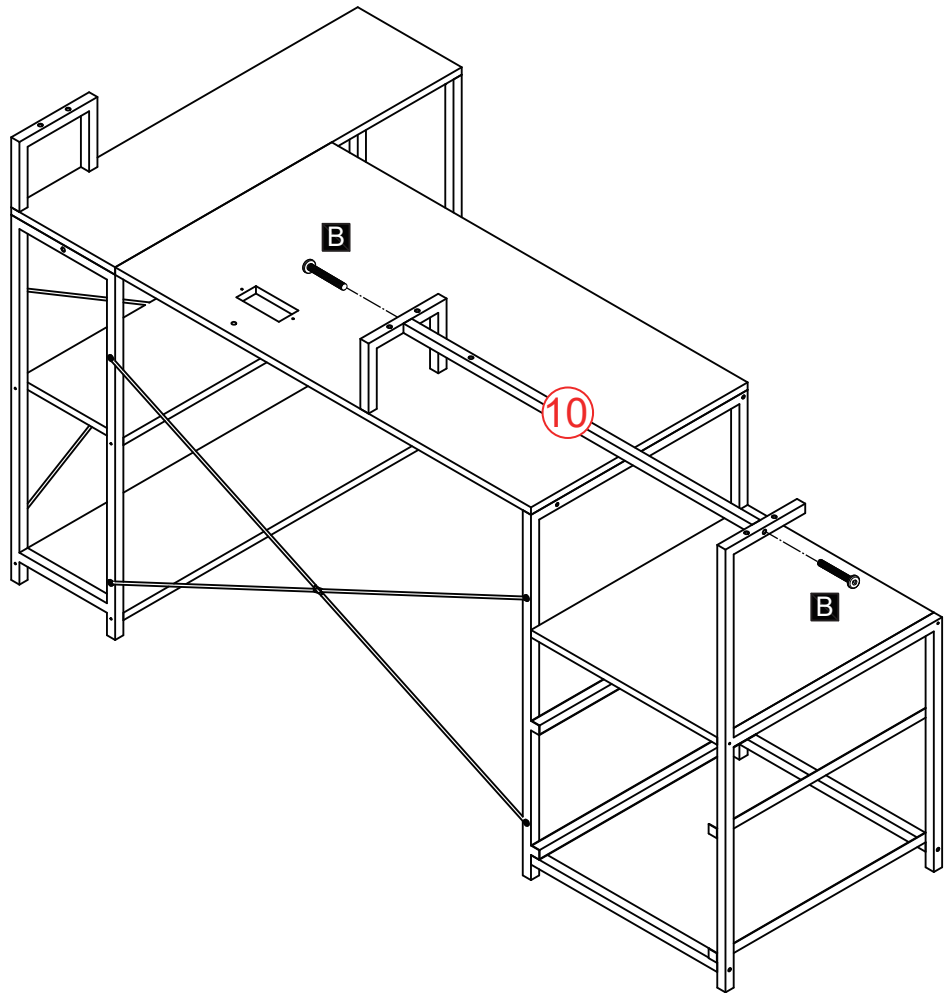

J X 2

K X 1

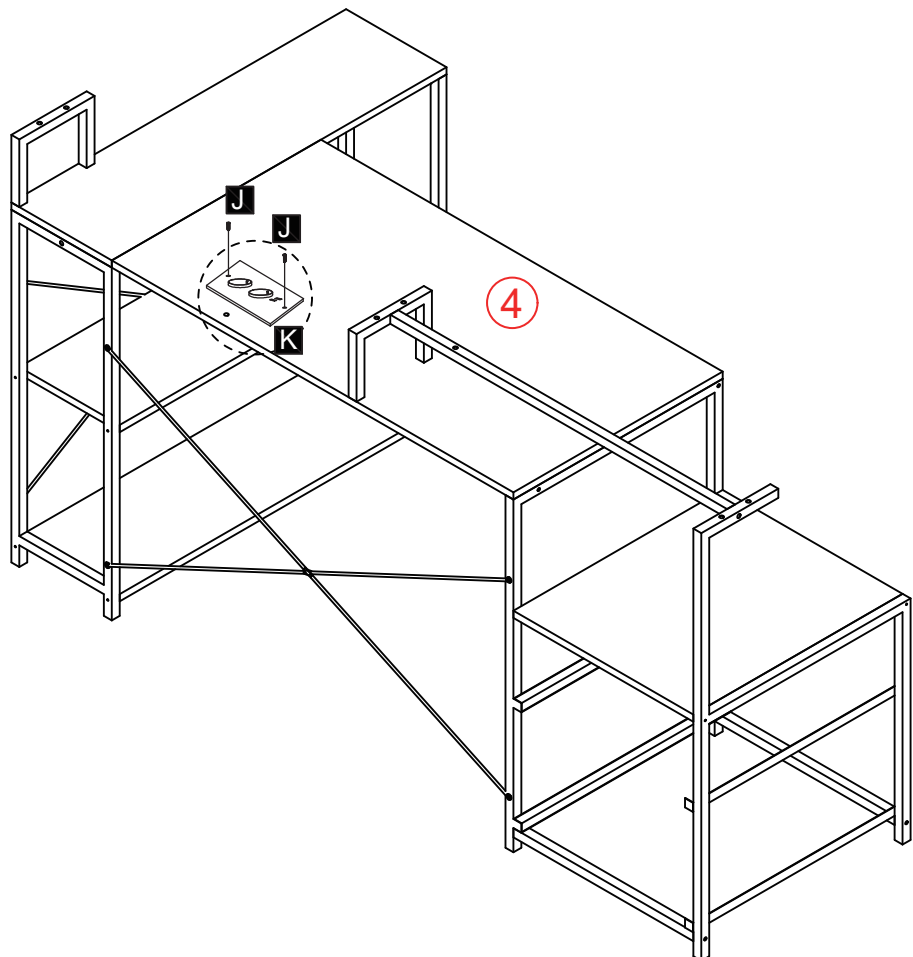

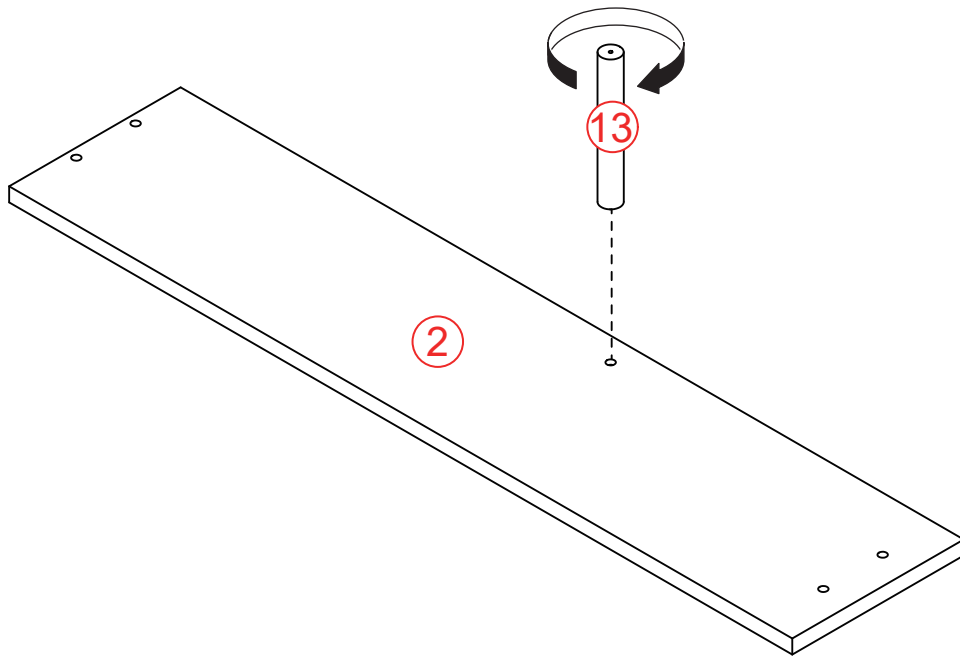

C X 8

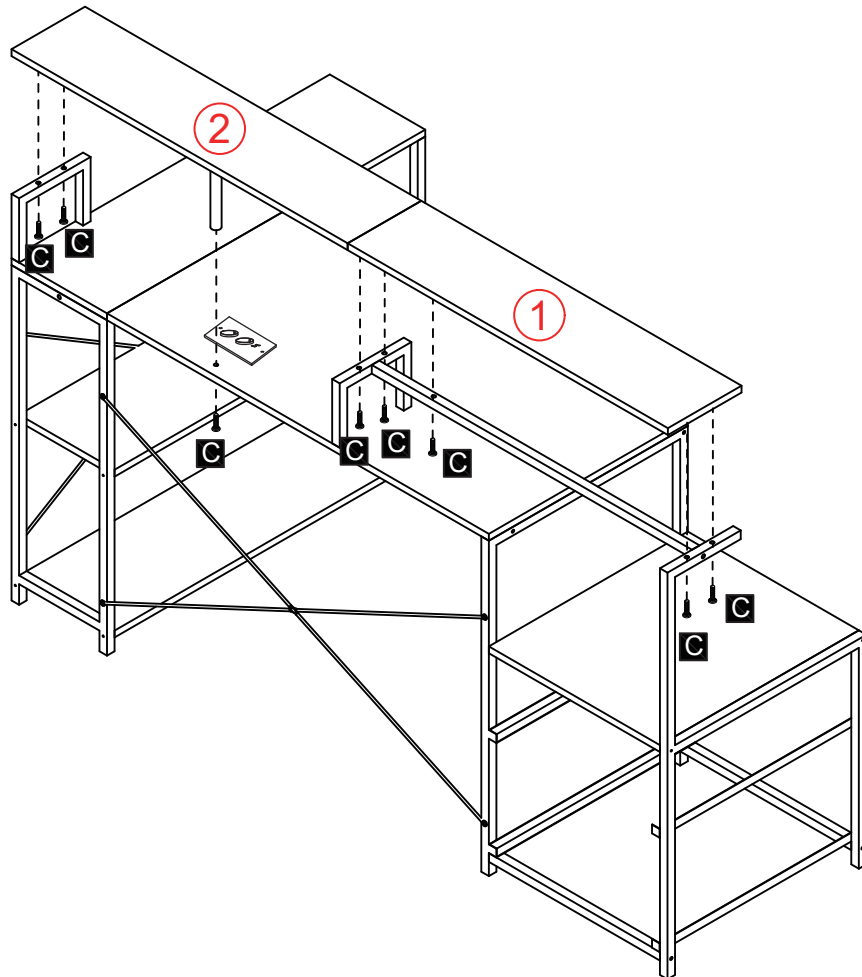

G X 2

M X 2

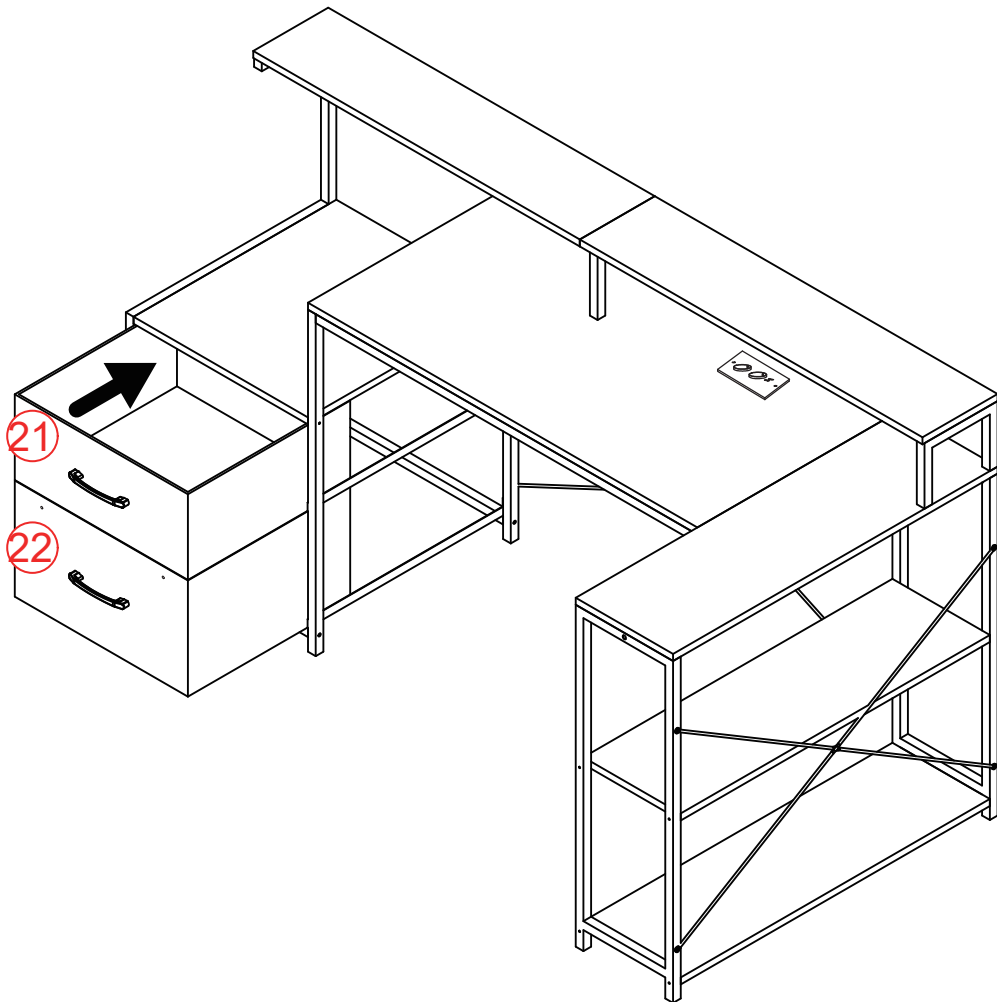
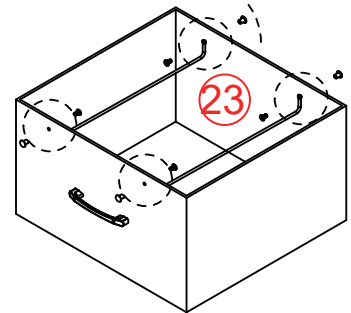
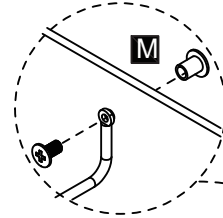
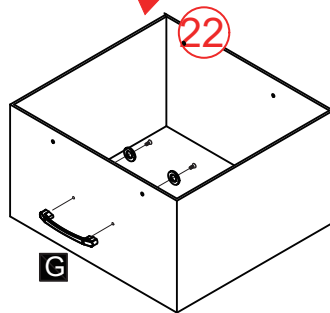
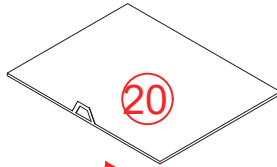
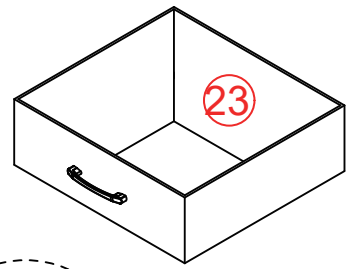
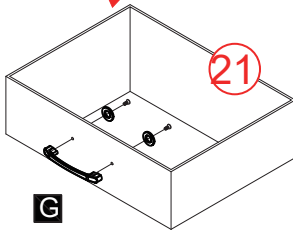
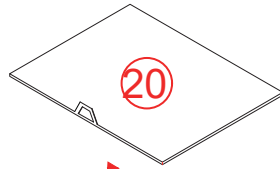
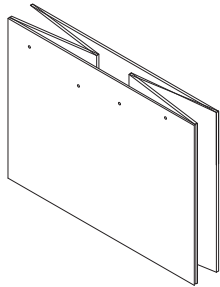
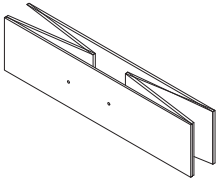

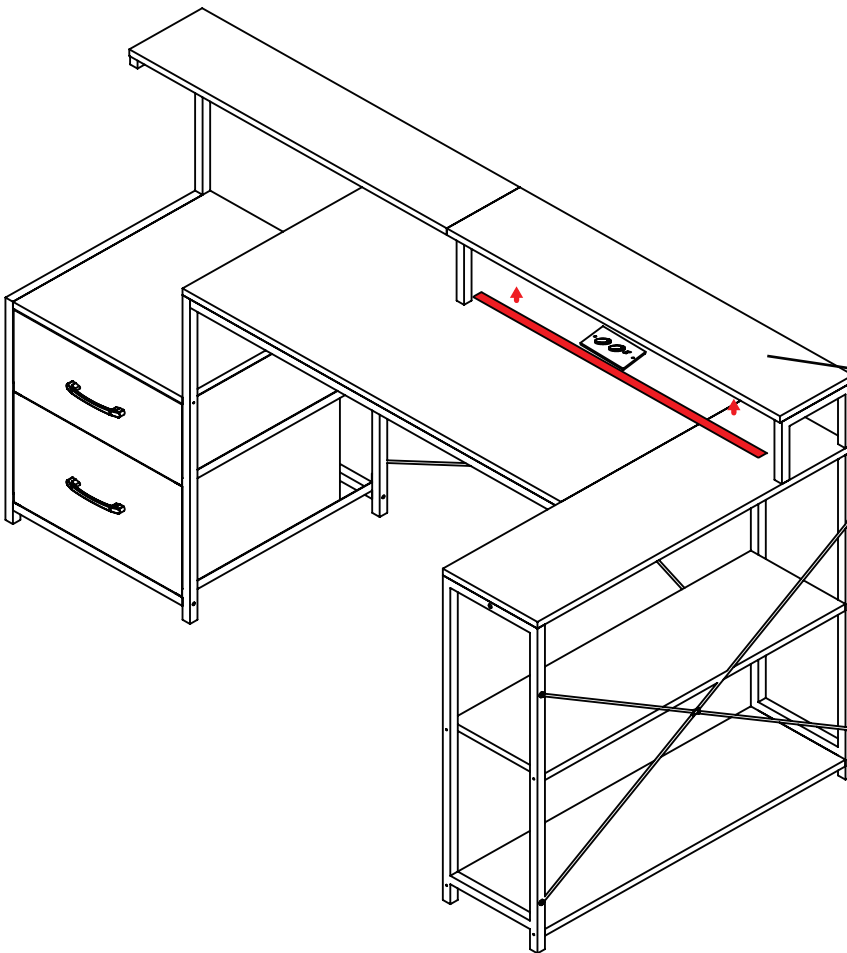

EN_LED Light Strip can be Post it under

Part 9 follow your needs.

FR_Les bandes lumineuses à LED peuvent être affichées sous la partie 9 en fonction de vos besoins.

ES_Tira de luz LED puede ser Publicar bajo la Parte 9 seguir sus necesidades.

PT_A faixa de luz LED pode ser colocada

na Parte 9 de acordo com as suas necessidades.

DE_LED Light Strip kann es unter Teil 9 folgen Sie Ihren Bedürfnissen.

IT_La striscia luminosa a LED può essere postata sotto la parte 9 per seguire le vostre esigenze.

RO_Banda LED EN poate fi lipită conform secțiunii 9, în funcție de necesități.



INDOOR USE ONLY

- **This product contains a light source of energy efficiency class <F>.**
- **The appliance must only be supplied at safety extra low voltage corresponding to the marking on the appliance.**
- To reduce the risk of strangulation the flexible wiring connected to this luminaire shall be effectively fixed to the wall if the wiring is within arm's reach.
- This appliance can be used by children aged from 8 years and above and persons with reduced physical, sensory or mental capabilities or lack of experience and knowledge if they have been given supervision or instruction concerning use of the appliance in a safe way and understand the hazards involved. Children shall not play with the appliance. Cleaning and user maintenance shall not be made by children without supervision.

SPECIFICATION

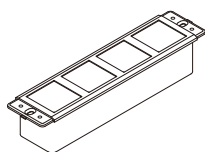

POWER INPUT: 220-240V~50Hz
 MAX LOAD: 2400W
 USB-A: 5V/2A (10W Max)
 Type-C: 5V/3A 9V/2A 12V/1.5A (18W Max)

If the supply cord is damaged, it must be replaced by the manufacturer, its service agent or similarly qualified persons in order to avoid a hazard.



À USAGE INTÉRIEUR EXCLUSIVEMENT

- **Ce produit contient une source lumineuse de classe d'efficacité énergétique <F>.**
- **L'appareil doit être alimenté uniquement sous la très basse tension de sécurité correspondant au marquage de l'appareil.**
- **Si le câble d'alimentation est endommagé, il doit être remplacé par le fabricant, son service après vente ou des personnes de qualification similaire afin d'éviter un danger.**
- Pour réduire le risque d'étranglement, le câblage souple raccordé à ce luminaire doit être fixé efficacement au mur si le câblage se situe dans le volume d'accessibilité au toucher.
- Cet appareil peut être utilisé par des enfants âgés d'au moins 8 ans et par des personnes ayant des capacités physiques, sensorielles ou mentales réduites ou dénuées d'expérience ou de connaissance, s'ils (si elles) sont correctement surveillé(e)s ou si des instructions relatives à l'utilisation de l'appareil en toute sécurité leur ont été données et si les risques encourus ont été appréhendés. Les enfants ne doivent pas jouer avec l'appareil. Le nettoyage et l'entretien par l'utilisateur ne doivent pas être effectués par des enfants sans surveillance

SPÉCIFICATIONS

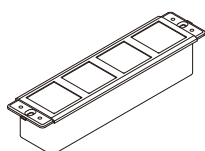

ALIMENTATION : 220-240V~50Hz
 CHARGE MAXIMALE : 2400W
 USB-A: 5V/2A (10W Max)
 Type-C: 5V/3A 9V/2A 12V/1.5A (18W Max)

Si le câble d'alimentation est endommagé, il doit être remplacé par le fabricant, son service après vente ou des personnes de qualification similaire afin d'éviter un danger.



NUR ZUR VERWENDUNG IN INNENRÄUMEN

- **Dieses Produkt enthält eine Lichtquelle der Energieeffizienzklasse <F>.**
- **Das Gerät ist nur mit SELV entsprechend der Kennzeichnung auf dem Gerät zu versorgen.**
- **Wenn die Netzanschlussleitung dieses Gerätes beschädigt wird, muss sie durch den Hersteller oder seinen Kundendienst oder eine ähnlich qualifizierte Person ersetzt werden, um Gefährdungen zu vermeiden.**
- Um die Gefahr einer Strangulierung zu verringern, müssen die an dieser Leuchte angeschlossenen flexiblen Kabel wirksam an der Wand befestigt werden, wenn sich die Kabel in Reichweite der Arme befinden.
- Dieses Gerät kann von Kindern ab 8 Jahren und darüber sowie von Personen mit verringerten physischen, sensorischen oder mentalen Fähigkeiten oder Mangel an Erfahrung und Wissen benutzt werden, wenn sie beaufsichtigt oder bezüglich des sicheren Gebrauchs des Gerätes unterwiesen wurden und die daraus
- resultierenden Gefahren verstehen. Kinder dürfen nicht mit dem Gerät spielen. Reinigung und Benutzer-Wartung dürfen nicht von Kindern ohne Beaufsichtigung durchgeführt werden

SPEZIFIKATIONEN

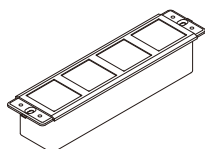

STROMVERSORGUNG: 220-240V~50Hz
MAX. BELASTUNG: 2400W
USB-A: 5V/2A (10W Max)
Type-C: 5V/3A 9V/2A 12V/1.5A (18W Max)

Si el cable de alimentación está dañado, debe ser reemplazado por el fabricante, su agente de servicio o personas igualmente calificadas para evitar un peligro.



USO SOLO EN INTERIORES

- **Este producto contiene una fuente de luz de clase de eficiencia energética <F>.**
- **El aparato solo debe alimentarse con una tensión de seguridad extra baja, conforme a la indicación marcada en el mismo.**
- **Si el cable de alimentación está dañado, debe ser reemplazado por el fabricante, su agente de servicio o personas igualmente calificadas para evitar un peligro.**
- Para reducir el riesgo de estrangulamiento, el cableado flexible conectado a esta luminaria debe fijarse eficazmente a la pared si el cableado está al alcance de la mano.
- Este aparato puede ser utilizado por niños a partir de 8 años y por personas con capacidades físicas, sensoriales o mentales reducidas o con falta de experiencia y conocimientos, siempre que hayan recibido supervisión o instrucciones sobre el uso seguro del aparato y comprendan los riesgos que conlleva. Los niños no deben jugar con el aparato. La limpieza y el mantenimiento por parte del usuario no deben ser realizados por niños sin supervisión

Especificaciones

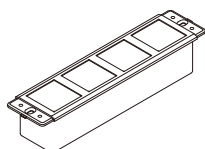

ENTRADA DE ALIMENTACIÓN: 220-240V~50Hz
CARGA MÁXIMA: 2400W
USB-A: 5V/2A (10W Max)
Type-C: 5V/3A 9V/2A 12V/1.5A (18W Max)

Se o cabo de alimentação estiver danificado, ele deve ser substituído pelo fabricante, seu agente de serviço ou pessoas igualmente qualificadas para evitar um perigo.



• **USO APENAS EM INTERIORES.**

- **Este produto contém uma fonte luminosa de classe de eficiência energética <F>.**
- **O aparelho só deve ser alimentado com tensão de segurança extra baixa, conforme indicado na marcação do próprio aparelho.**
- **Se o cabo de alimentação estiver danificado, ele deve ser substituído pelo fabricante, seu agente de serviço ou pessoas igualmente qualificadas para evitar um perigo.**
- Para reduzir o risco de estrangulamento, a cablagem flexível ligada a esta luminária deve ser fixada de forma eficaz à parede, se a cablagem estiver ao alcance da mão.
- Este aparelho pode ser utilizado por crianças com idade igual ou superior a 8 anos e por pessoas com capacidades físicas, sensoriais ou mentais reduzidas ou com falta de experiência e conhecimento, desde que tenham recebido supervisão ou instruções sobre a utilização segura do aparelho e compreendam os riscos envolvidos. As crianças não devem brincar com o aparelho. A limpeza e a manutenção pelo utilizador não devem ser feitas por crianças sem supervisão

Especificações

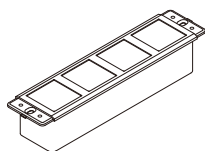

ENTRADA DE ALIMENTAÇÃO: 220-240V~50Hz
 CARGA MÁXIMA: 2400W
 USB-A: 5V/2A (10W Max)
 Type-C: 5V/3A 9V/2A 12V/1.5A (18W Max)

Wenn die Netzanschlussleitung dieses Gerätes beschädigt wird, muss sie durch den Hersteller oder seinen Kundendienst oder eine ähnlich qualifizierte Person ersetzt werden, um Gefährdungen zu vermeiden.



• **SOLO PER USO INTERNO**

- **Questo prodotto contiene una sorgente luminosa di classe di efficienza energetica <F>.**
- **L'apparecchio deve essere alimentato soltanto con tensione di sicurezza extra bassa, conforme alla marcatura riportata sull'apparecchio stesso.**
- **Se il cavo di alimentazione è danneggiato, deve essere sostituito dal produttore, dal suo agente di servizio o da persone altrettanto qualificate per evitare pericoli.**
- Per ridurre il rischio di strangolamento, il cavo flessibile collegato a questo apparecchio deve essere fissato saldamente alla parete se si trova a portata di mano.
- Questo apparecchio può essere utilizzato da bambini di età superiore agli 8 anni e da persone con capacità fisiche, sensoriali o mentali ridotte o con mancanza di esperienza e conoscenza, purché siano stati istruiti o sorvegliati sull'uso sicuro dell'apparecchio e comprendano i pericoli che esso comporta. I bambini non devono giocare con l'apparecchio. La pulizia e la manutenzione da parte dell'utente non devono essere effettuate da bambini senza supervisione

Specifiche

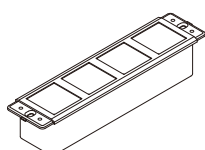

ALIMENTAZIONE: 220-240V~50Hz
 CARICO MASSIMO: 2400W
 USB-A: 5V/2A (10W Max)
 Type-C: 5V/3A 9V/2A 12V/1.5A (18W Max)

Se il cavo di alimentazione è danneggiato, deve essere sostituito dal produttore, dal suo agente di servizio o da persone altrettanto qualificate per evitare pericoli.



• DOAR PENTRU UTILIZARE ÎN INTERIOR

- Acest produs conține o sursă de lumină din clasa de eficiență energetică <F>.
- Aparatul trebuie alimentat exclusiv cu tensiune de siguranță foarte joasă, conform marajului de pe aparat.
- Pentru a reduce riscul de strangulare, cablul flexibil conectat la acest corp de iluminat trebuie fixat corespunzător de perete, în cazul în care acesta se află la îndemâna mâinii.
- Acest aparat poate fi utilizat de copii cu vârsta de cel puțin 8 ani și de persoane cu capacități fizice, senzoriale sau mentale reduse sau cu lipsă de experiență și cunoștințe, cu condiția să fi primit supraveghere sau instrucțiuni privind utilizarea aparatului în condiții de siguranță și să înțeleagă pericolele implicate. Copiii nu trebuie să se joace cu aparatul. Curățarea și întreținerea de către utilizator nu trebuie efectuate de copii fără supraveghere.

SPECIFICAȚII

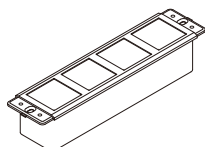

ALIMENTARE: 220-240V~50Hz
SARCINĂ MAXIMĂ: 2400W
USB-A: 5V/2A (10W Max)
Type-C: 5V/3A 9V/2A 12V/1.5A (18W Max)

În cazul în care cablul de alimentare este deteriorat, acesta trebuie înlocuit de către producător, de către un reprezentant al serviciului de service sau de către persoane cu calificare similară, pentru a evita orice pericol.

If you have any questions, please contact our customer care center, Our contact details are below:

US

 001-877-644-9366

 customerservice@aosom.com

Imported by Aosom LLC
7777 Center Ave. Suite 430
Huntington Beach, CA 92647-9998 USA
MADE IN CHINA

Si tiene alguna pregunta, comuníquese con nuestro Centro de Atención al Cliente, Nuestros datos de contacto son los siguientes:

ES

 0034-931294512

 atencioncliente@aosom.es

IMPORTADOR/Fabricante/REP:
SPANISH AOSOM, S.L.
C/ROC GROS,Nº15.08550, ELS HOSTALETES DE
BALENYÀ, SPAIN.
B66295775
HECHO EN CHINA

Se tiver alguma dúvida, por favor contacte o nosso Centro de Atendimento ao Cliente, Os nossos dados de contacto são os seguintes:

 0034-931294512

 info@aosom.pt.

IMPORTADOR/Fabricante/REP:
SPANISH AOSOM, S.L.
C.ROC GROS N.15, 08550. ELS HOSTALETES DE
BALENYÀ
FEITO NA CHINA

If you have any questions, please contact our customer care center, Our contact details are below:

CA

 416-792-6088

 customerservice@aosom.ca

Imported by Aosom Canada Inc.
7270 Woodbine Avenue, Unit 307, Markham,
Ontario Canada L3R 4B9
MADE IN CHINA

Si vous avez la moindre question, veuillez contacter notre centre d'assistance à la clientèle, Nos coordonnées sont les suivantes:

 416-792-6088

 customerservice@aosom.ca

Importé par Aosom Canada Inc.
7270 Woodbine Avenue, unité 307,
Markham, Ontario Canada L3R 4B9
FABRIQUÉ EN CHINE

In caso di dubbio, si prega di contattare il nostro centro assistenza clienti, I nostri dettagli di contatto sono di seguito:

IT

 0039-0249471447

 clienti@aosom.it

IMPORTATO DA/Produttore/REP:
AOSOM Italy srl
Centro Direzionale Milanofiori
Strada 1 Palazzo F1
20057 Assago (MI)
P.I.: 08567220960
FATTO IN CINA

If you have any questions, please contact our customer care center, Our contact details are below:

UK

 0044-800-240-4004

 enquiries@mhstar.co.uk

IMPORTER ADDRESS:
MH STAR UK Ltd
1 Northampton Cross Logistics Park
Northampton Cross Road
Northampton
NN4 9FH
MADE IN CHINA

Wenn Sie Fragen haben, wenden Sie sich bitte an unser Kundendienstzentrum, Unsere Kontaktdaten stehen unten:

DE

 0049-0(40)-87408465

 service@aosom.de

ADRESSE DES IMPORTEURE/Hersteller/REP:
MH Handel GmbH
Wendenstraße 309
D-20537 Hamburg
Germany
IN CHINA HERGESTELLT

Si vous avez la moindre question, veuillez contacter notre centre d'assistance à la clientèle, Nos coordonnées sont les suivantes:

FR

 0033-1-84166106

 aosom@mhfrance.fr

Importé par/Fabricant/REP:
MH FRANCE
2 Rue Maurice Hartmann
92130 Issy Les Moulineaux
France
FABRIQUÉ EN CHINE



FR

**DONNEZ
OU
RECYCLEZ**



ASSOCIATION

OU



LIVRAISON

OU



DÉCHÈTERIE

Adresses sur quefairedemesdechets.fr

If you have any questions, please contact our customer care center, Our contact details are below:

US

 001-877-644-9366

 customerservice@aosom.com

Imported by Aosom LLC
7777 Center Ave. Suite 430
Huntington Beach, CA 92647-9998 USA
MADE IN CHINA

Si tiene alguna pregunta, comuníquese con nuestro Centro de Atención al Cliente, Nuestros datos de contacto son los siguientes:

ES

 0034-931294512

 atencioncliente@aosom.es

IMPORTADOR/Fabricante/REP:
SPANISH AOSOM, S.L.
C/ROC GROS,Nº15.08550, ELS HOSTALETES DE
BALENYÀ, SPAIN.
B66295775
HECHO EN CHINA

Se tiver alguma dúvida, por favor contacte o nosso Centro de Atendimento ao Cliente, Os nossos dados de contacto são os seguintes:

 0034-931294512

 info@aosom.pt.

IMPORTADOR/Fabricante/REP:
SPANISH AOSOM, S.L.
C.ROC GROS N.15, 08550. ELS HOSTALETES DE
BALENYÀ
FEITO NA CHINA

If you have any questions, please contact our customer care center, Our contact details are below:

CA

 416-792-6088

 customerservice@aosom.ca

Imported by Aosom Canada Inc.
7270 Woodbine Avenue, Unit 307, Markham,
Ontario Canada L3R 4B9
MADE IN CHINA

Si vous avez la moindre question, veuillez contacter notre centre d'assistance à la clientèle, Nos coordonnées sont les suivantes:

 416-792-6088

 customerservice@aosom.ca

Importé par Aosom Canada Inc.
7270 Woodbine Avenue, unité 307,
Markham, Ontario Canada L3R 4B9
FABRIQUÉ EN CHINE

In caso di dubbio, si prega di contattare il nostro centro assistenza clienti, I nostri dettagli di contatto sono di seguito:

IT

 0039-0249471447

 clienti@aosom.it

IMPORTATO DA/Produttore/REP:
AOSOM Italy srl
Centro Direzionale Milanofiori
Strada 1 Palazzo F1
20057 Assago (MI)
P.I.: 08567220960
FATTO IN CINA

If you have any questions, please contact our customer care center, Our contact details are below:

UK

 0044-800-240-4004

 enquiries@mhstar.co.uk

IMPORTER ADDRESS:
MH STAR UK Ltd
1 Northampton Cross Logistics Park
Northampton Cross Road
Northampton
NN4 9FH
MADE IN CHINA

Wenn Sie Fragen haben, wenden Sie sich bitte an unser Kundendienstzentrum, Unsere Kontaktdaten stehen unten:

DE

 0049-0(40)-87408465

 service@aosom.de

ADRESSE DES IMPORTEURE/Hersteller/REP:
MH Handel GmbH
Wendenstraße 309
D-20537 Hamburg
Germany
IN CHINA HERGESTELLT

Si vous avez la moindre question, veuillez contacter notre centre d'assistance à la clientèle, Nos coordonnées sont les suivantes:

FR

 0033-1-84166106

 aosom@mhfrance.fr

Importé par/Fabricant/REP:
MH FRANCE
2 Rue Maurice Hartmann
92130 Issy Les Moulineaux
France
FABRIQUÉ EN CHINE



FR

Cet appareil, ses accessoires, cordons et batteries se recyclent

REPRISE À LA LIVRAISON



OU

À DÉPOSER EN MAGASIN



OU

À DÉPOSER EN DÉCHÈTERIE



Points de collecte sur www.quefairedemesdechets.fr
Privilégiez la réparation ou le don de votre appareil !