

EN_IMPORTANT, RETAIN FOR FUTURE REFERENCE: READ CAREFULLY.

FR_IMPORTANT: A LIRE ATTENTIVEMENT ET À CONSERVER POUR CONSULTATION ULTÉRIEURE.

ES_IMPORTANTE, LEA Y GUARDE PARA FUTURAS REFERENCIAS.

PT_IMPORTANTE, RETER PARA REFERÊNCIA FUTURA: LEIA ATENTAMENTE.

DE_WICHTIG! SORGFÄLTIG LESEN UND FÜR SPÄTERES NACHSCHLAGEN AUFBEWAHREN.

IT_IMPORTANTE! CONSERVARE IL PRESENTE MANUALE PER FUTURO RIFERIMENTO E LEGGERLO ATTENTAMENTE.



IF HAVE THIS ACCESSORY

NOTE DIFFERENT MODELS

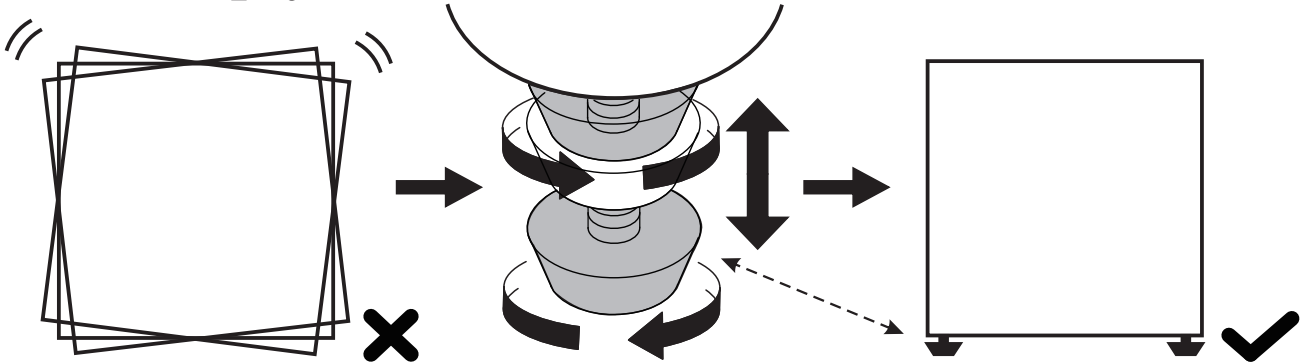

- EN** Adjust up and down for balance
- FR** Ajuster l'équilibre vers le haut et le bas
- ES** Ajuste hacia arriba y abajo para equilibrar
- PT** Ajustar para cima e para baixo para obter equilibrio
- DE** Nach oben und unten für das Gleichgewicht einstellen
- IT** Regolare il bilanciamento verso l'alto e verso il basso

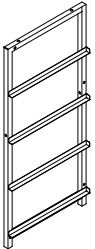
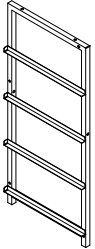
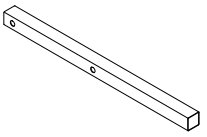
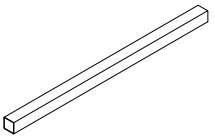
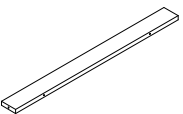
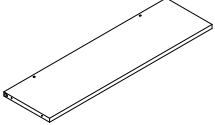
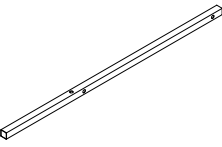
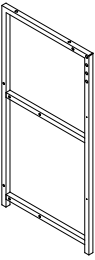
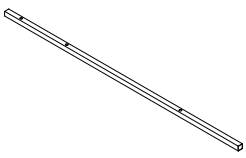
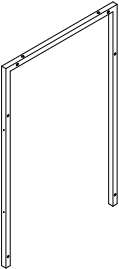
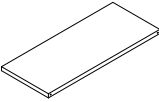
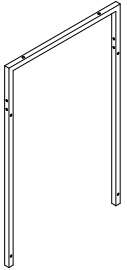

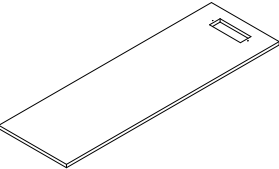
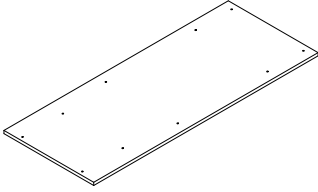
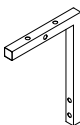
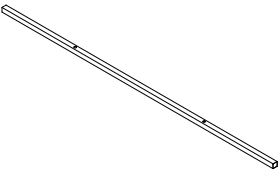
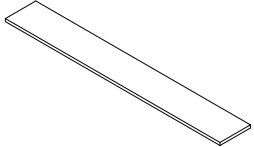
 A x2	 B x2	 C x1
 D x2	 E x2	 F x2
 G x1	 H x1	 I x2
 J x1	 K x2	 L x1
 M x1	 N x1	 O x1
 P x2	 Q x1	 R x1

S x2





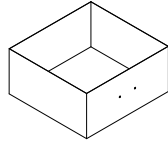

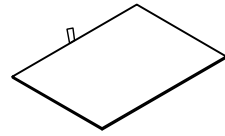

T x4

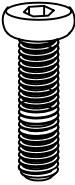
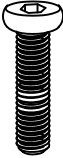

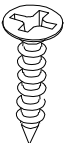
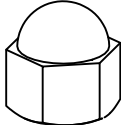
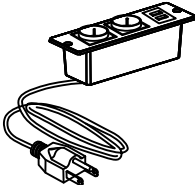
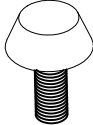
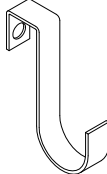
U x4

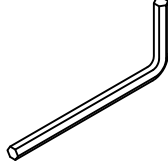

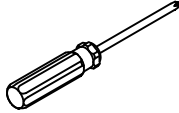
 <p>① x 2 M6*40 +1 (spare)</p>	 <p>② x39 M6*28 +2 (spare)</p>	 <p>③ x 5 M6*10 +1 (spare)</p>
 <p>④ x28 M5*40 +2 (spare)</p>	 <p>⑤ x 2 3.5*14mm +1 (spare)</p>	 <p>⑥ x 3 M6 +1 (spare)</p>
 <p>⑦ x1</p>	 <p>⑧ x10 M6</p>	 <p>⑨ x2 12*47*65</p>
 <p>⑩ x8 M4*10</p>	 <p>⑪ x4</p>	 <p>⑫ x1 M4</p>
 <p>⑬ x1 1.5*10*70</p>	 <p>⑭ x1</p>	

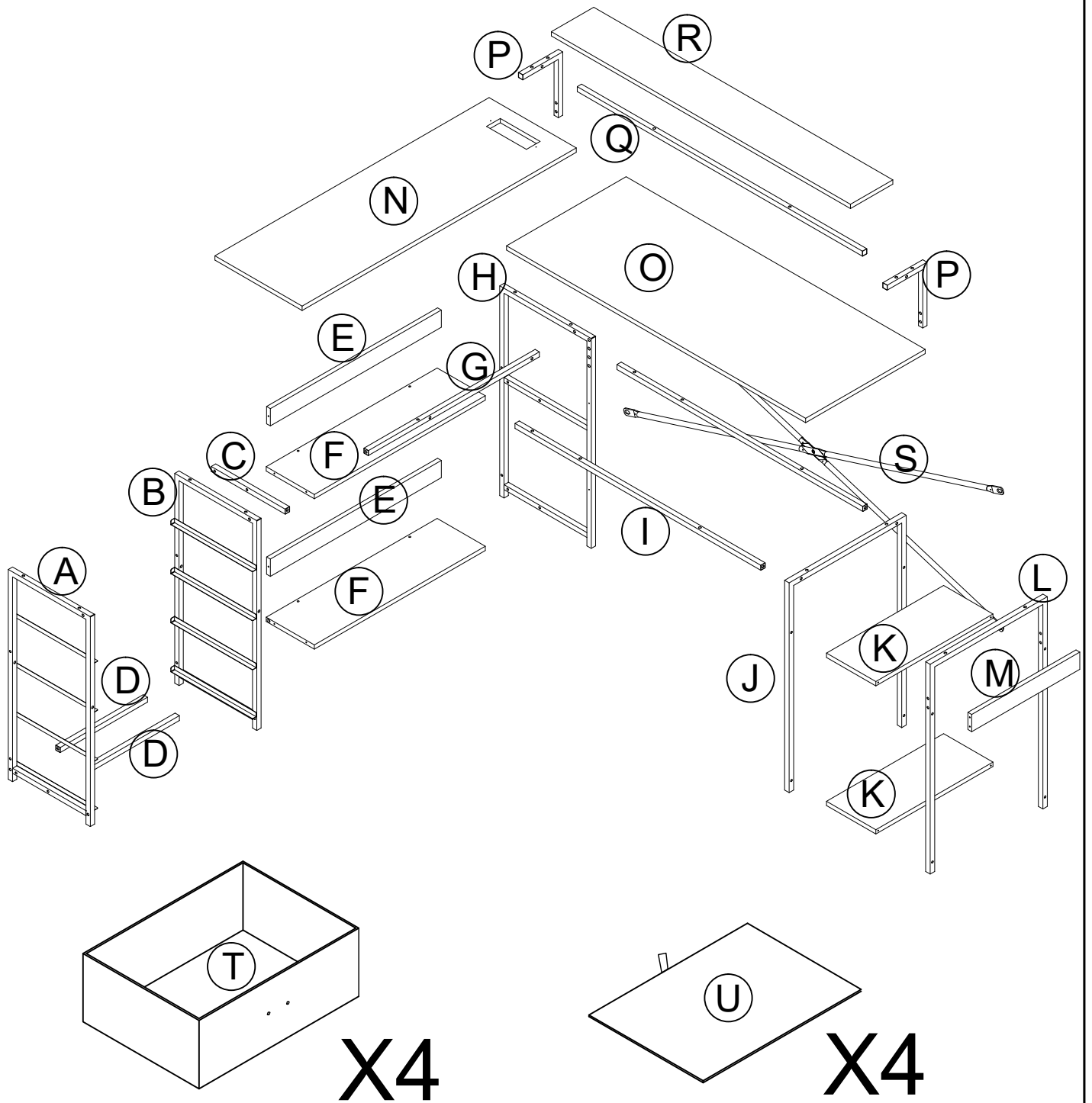



x2

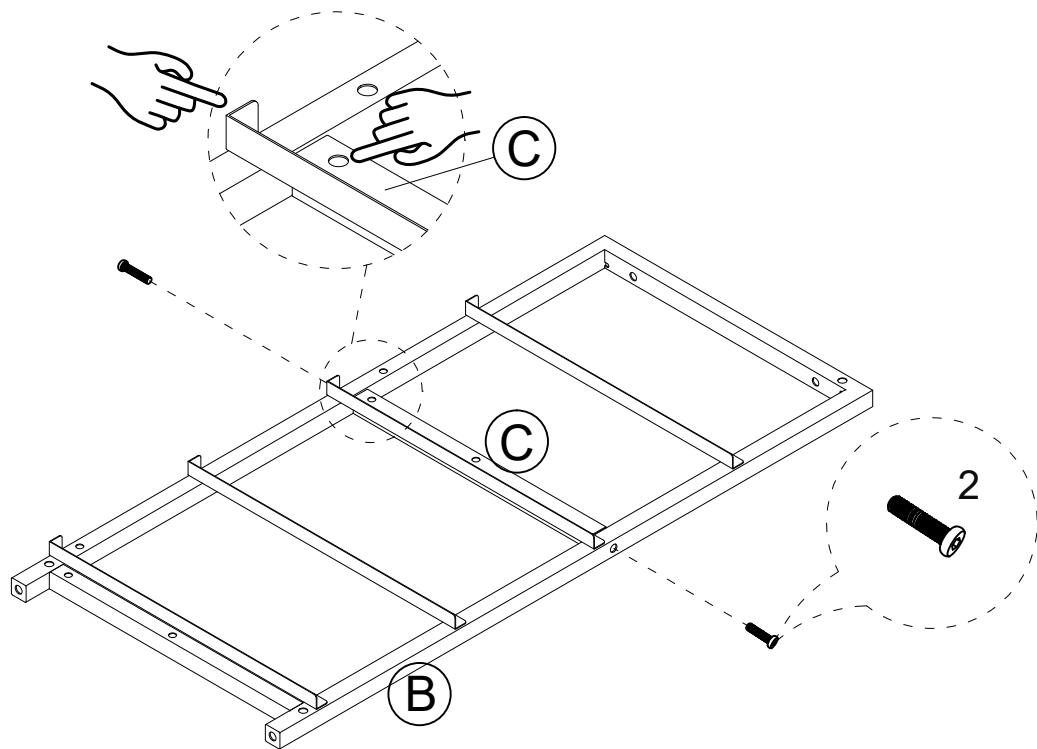

x2

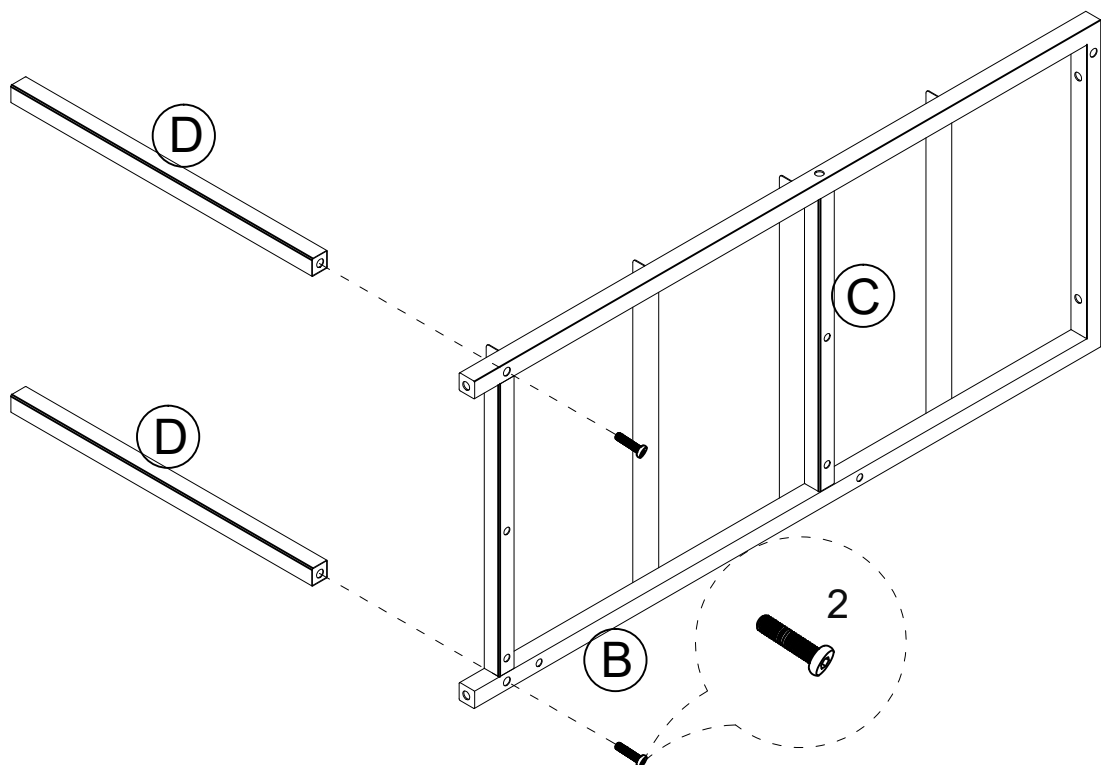

2

x2

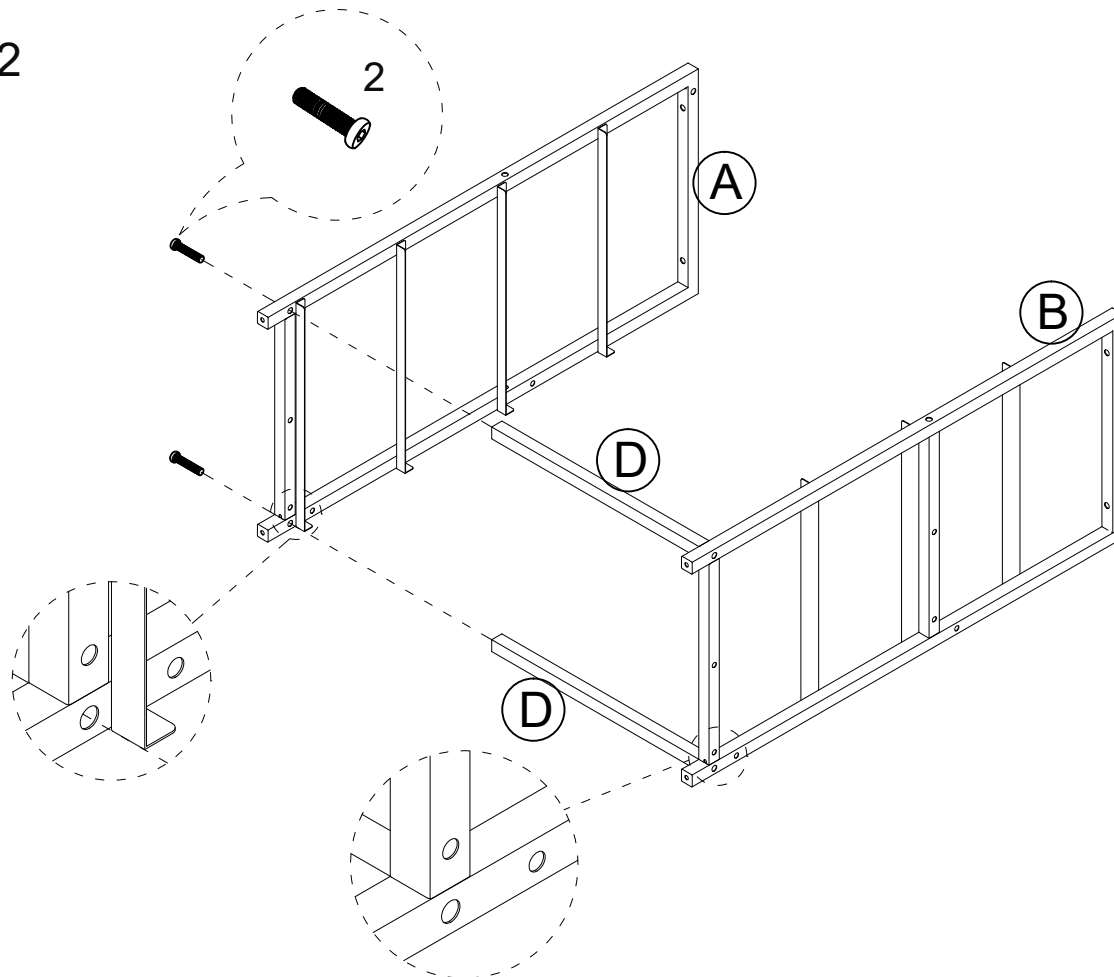

4

x4

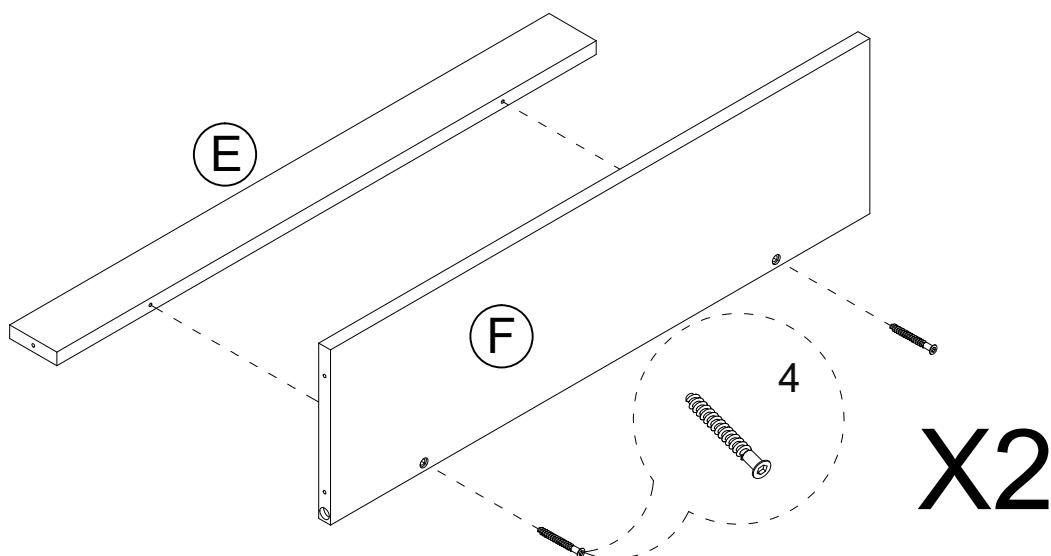

4

x6

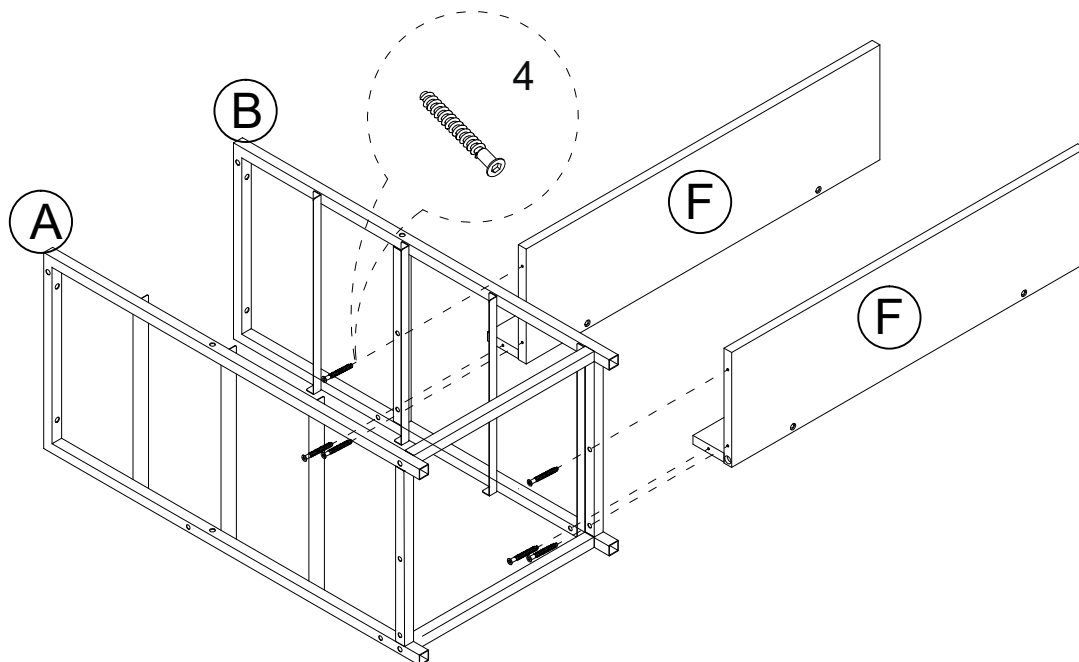

2

x1

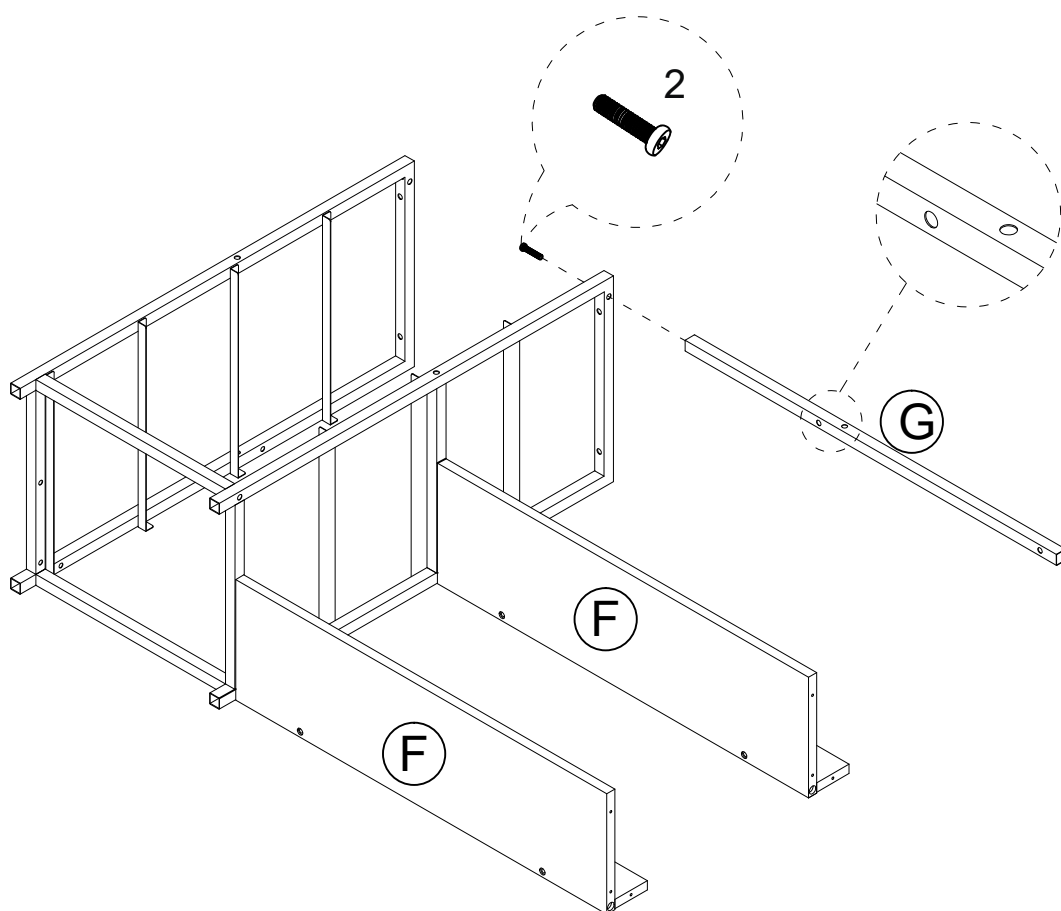

- 2 x1
- 4 x6
- 8 x6

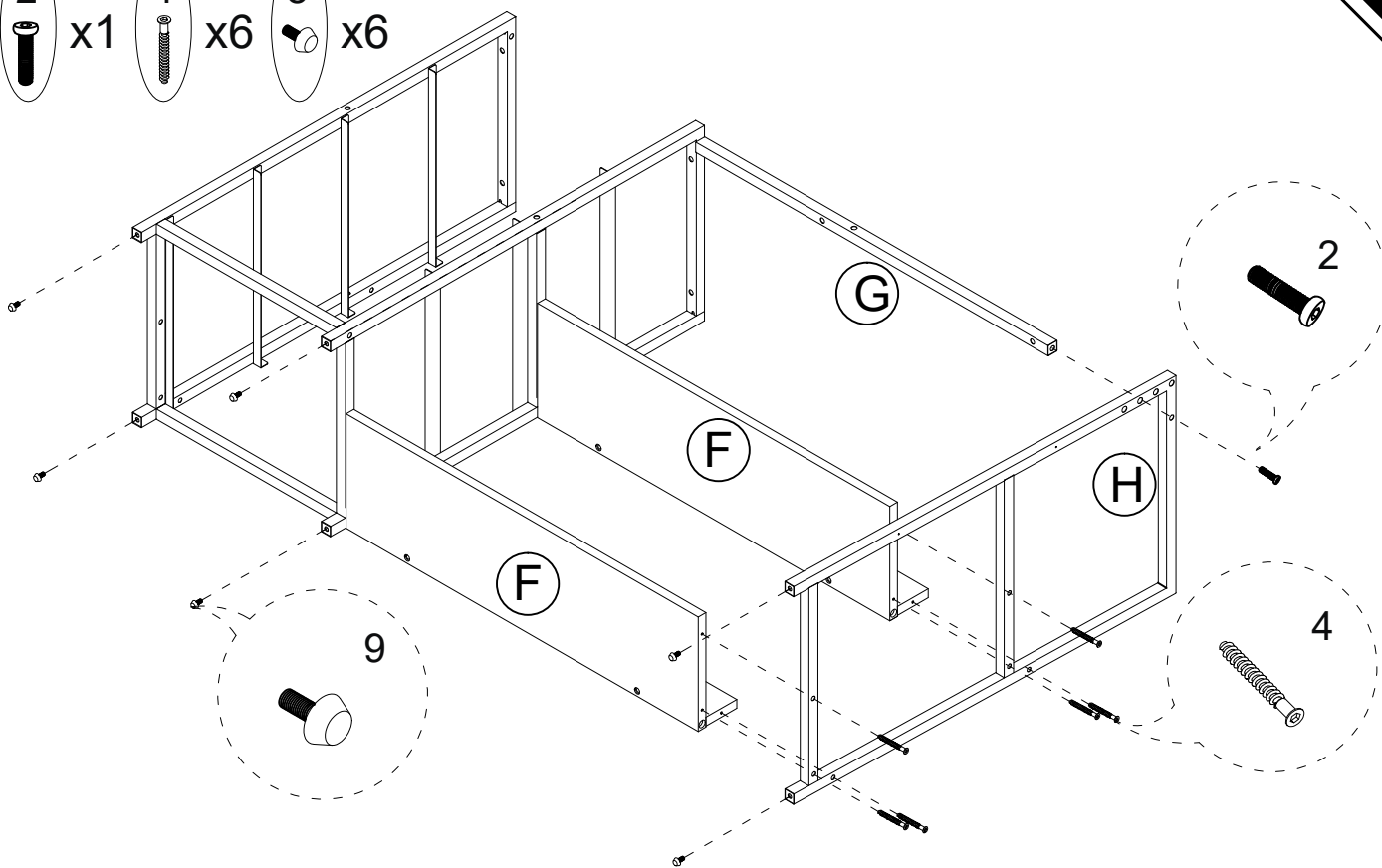

- 4 x4

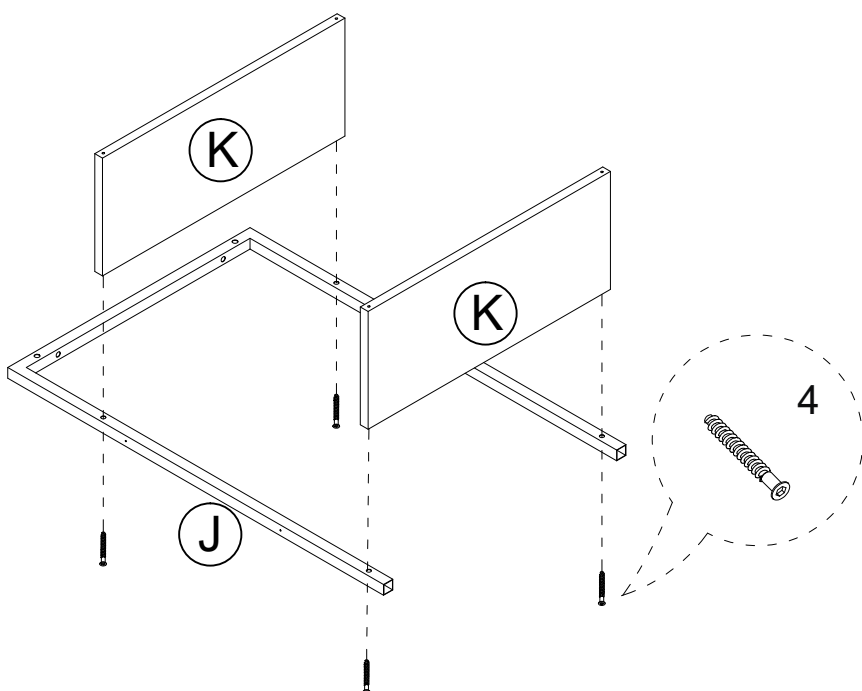

4

x4

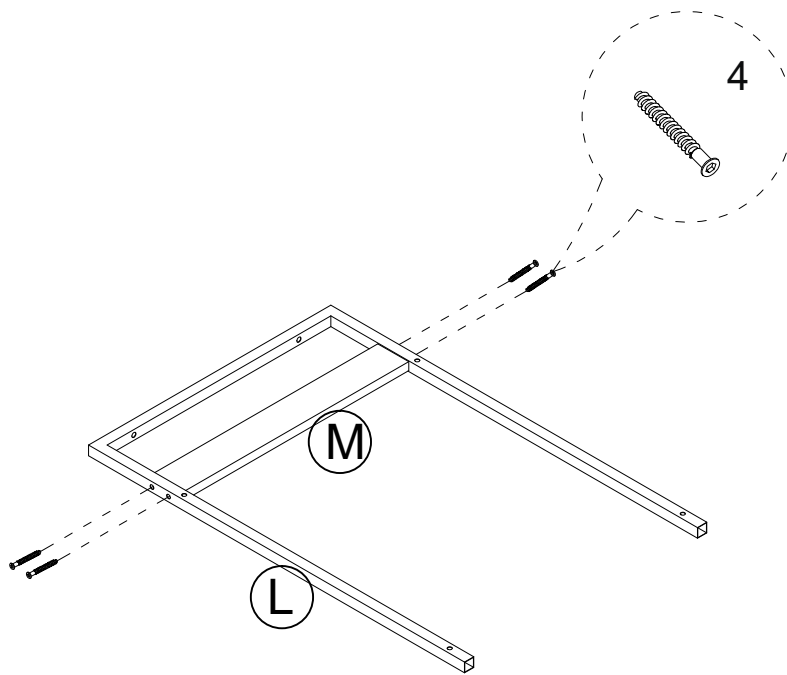

4

x4

8

x4

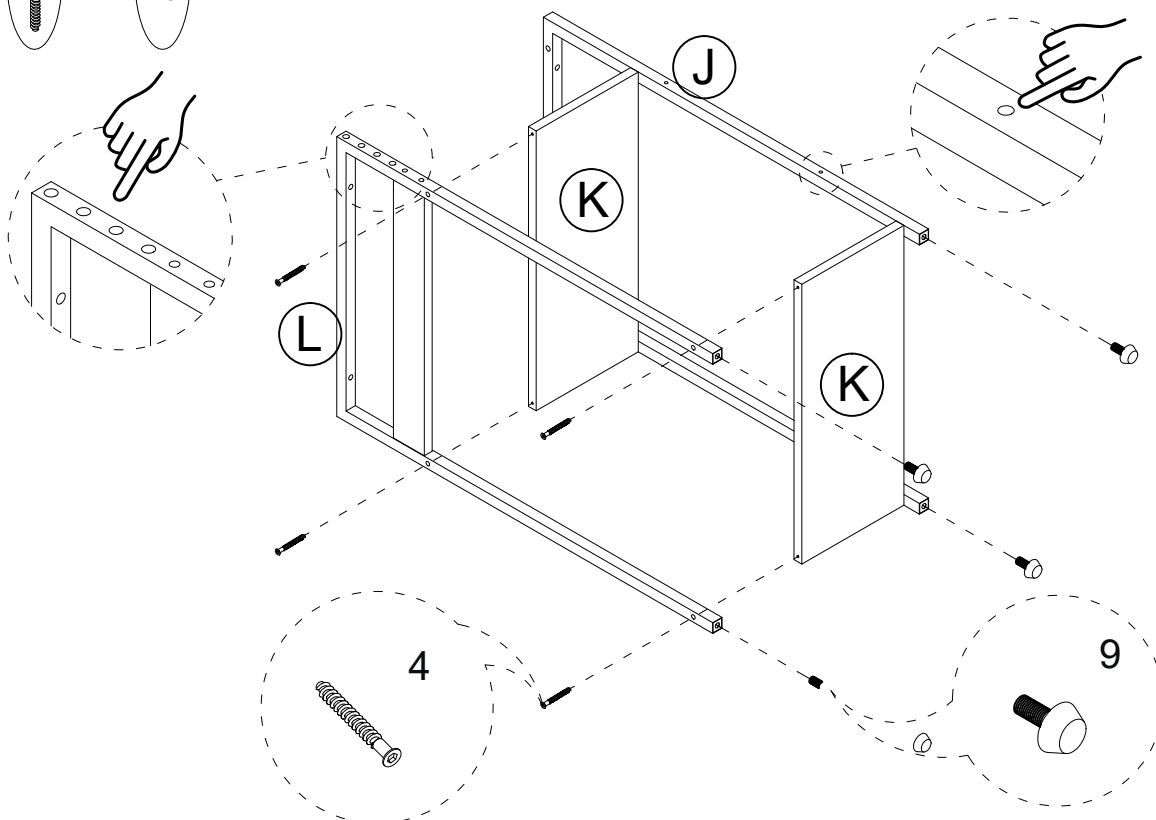



x2

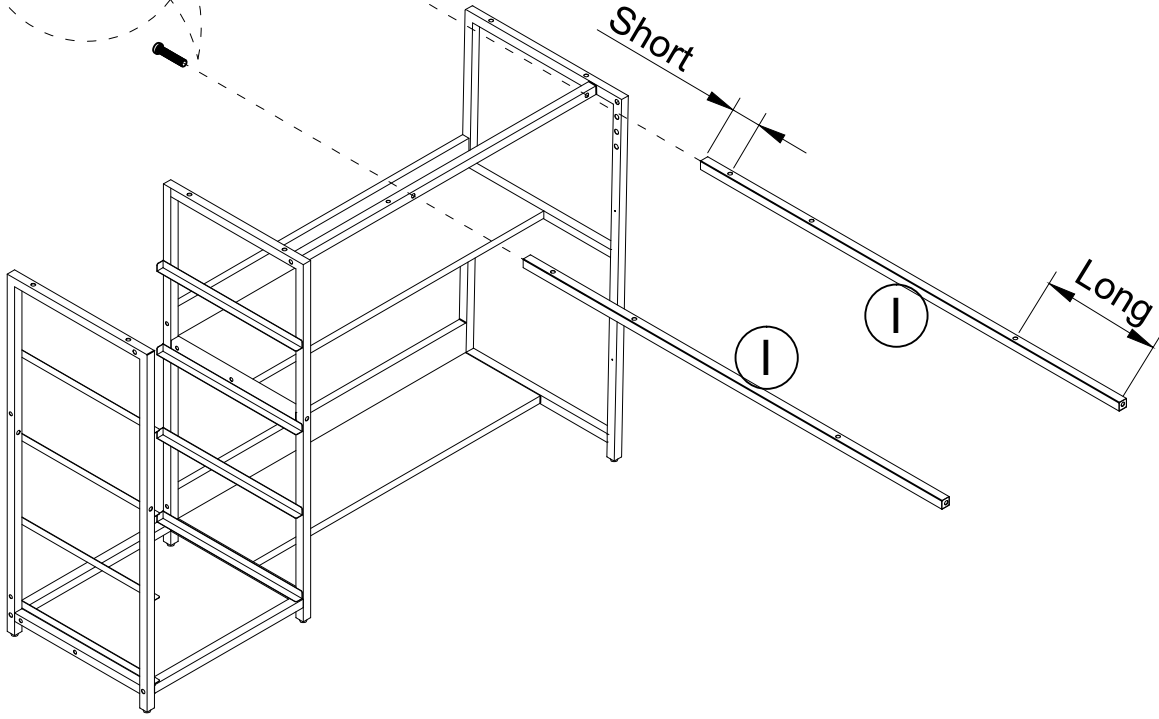
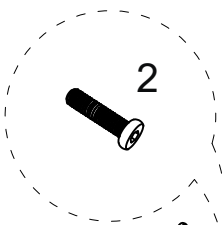

x2

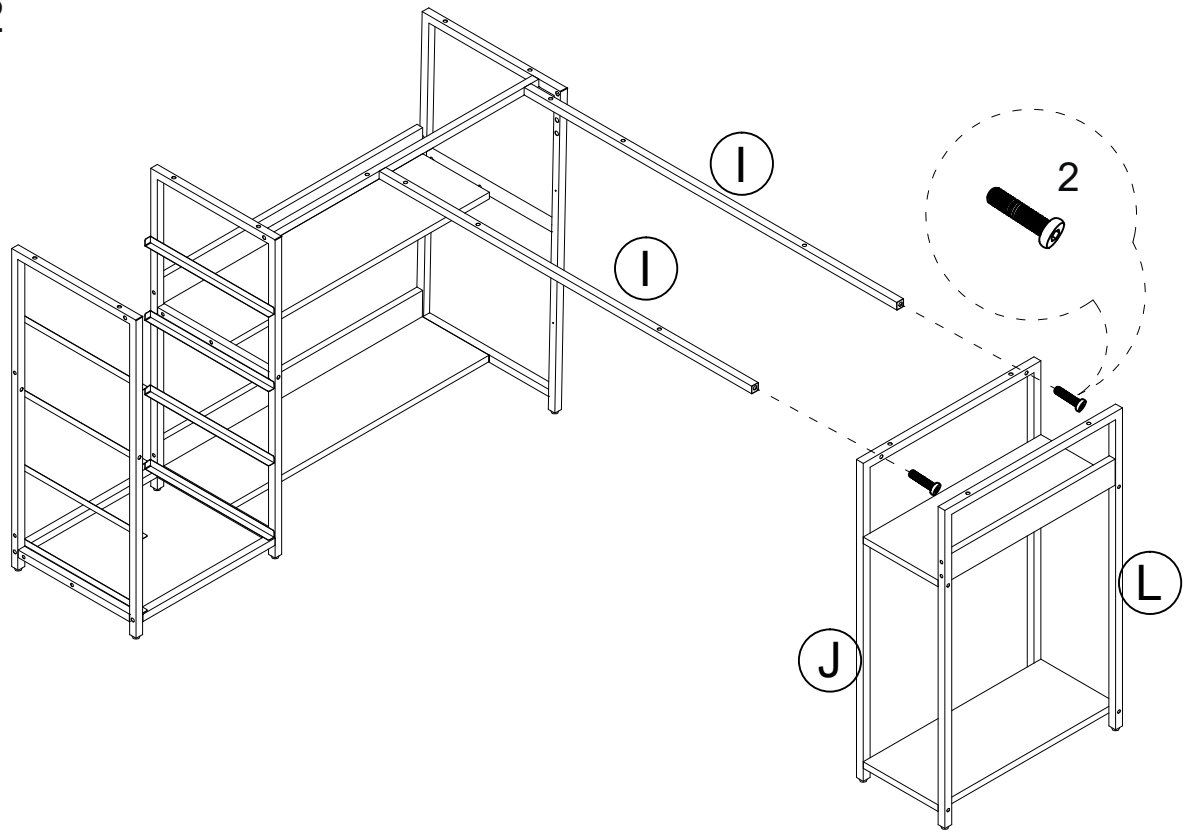
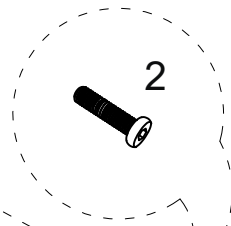



x10

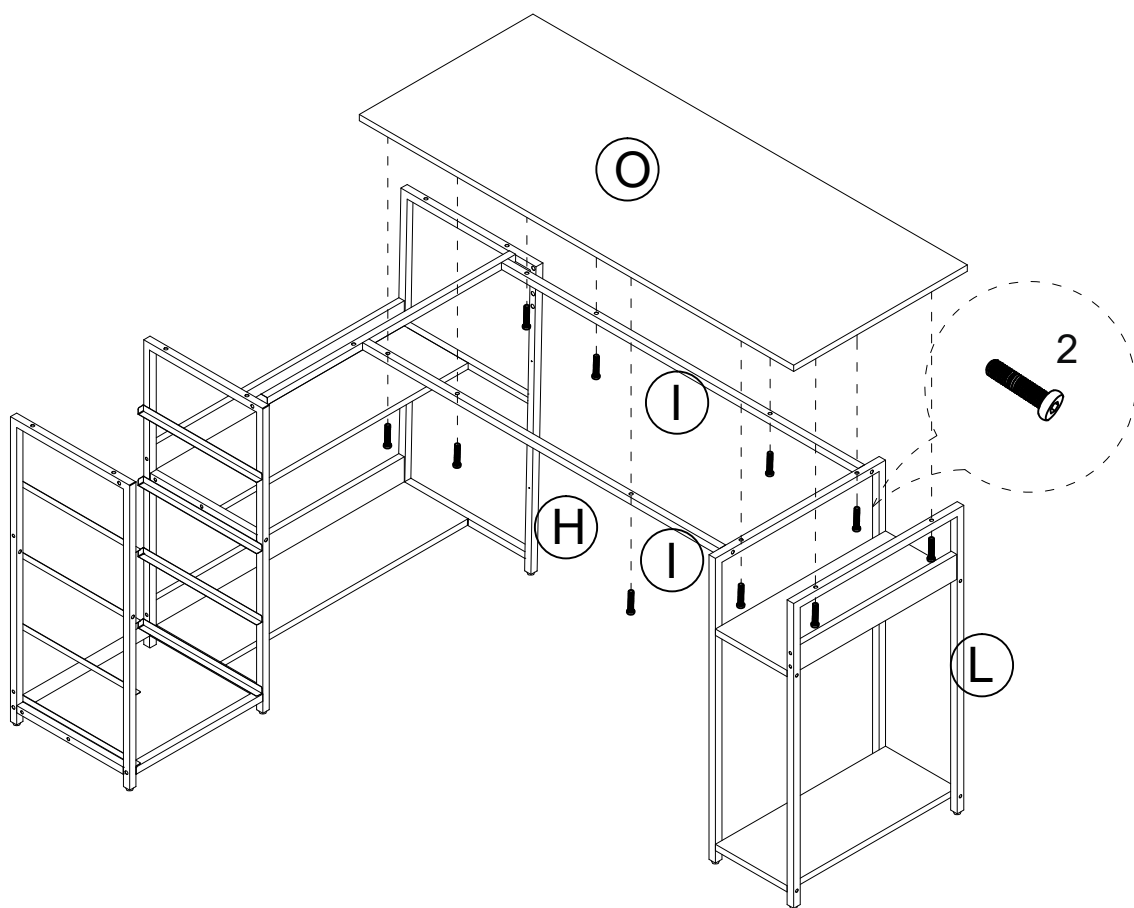

x7

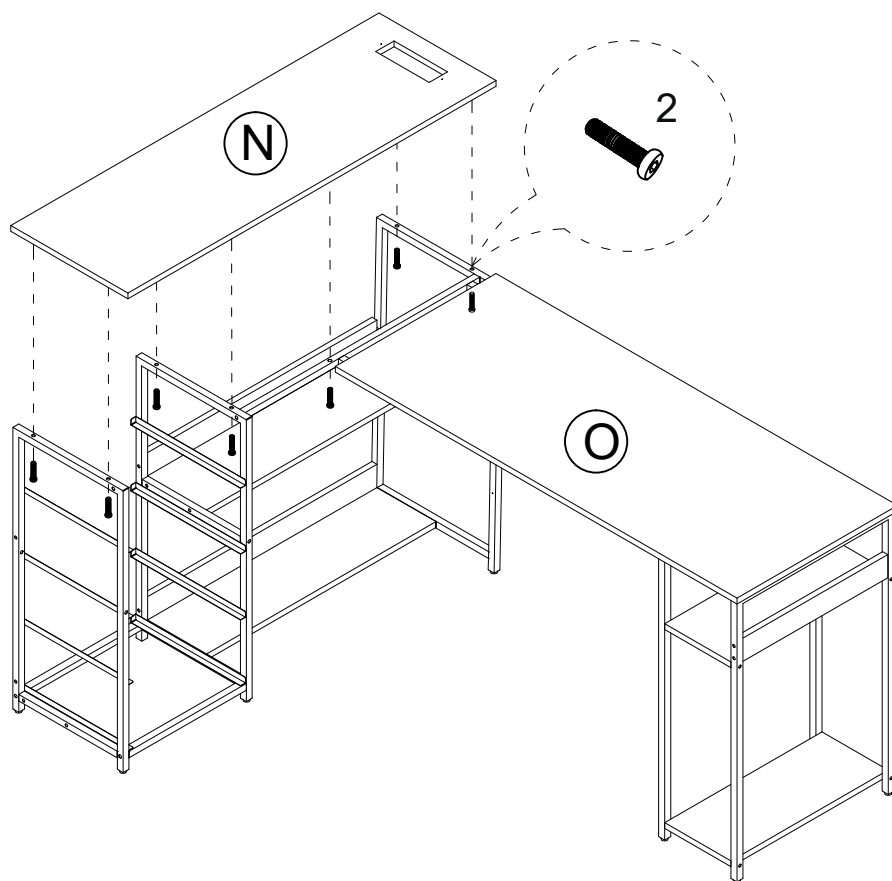

2 x2

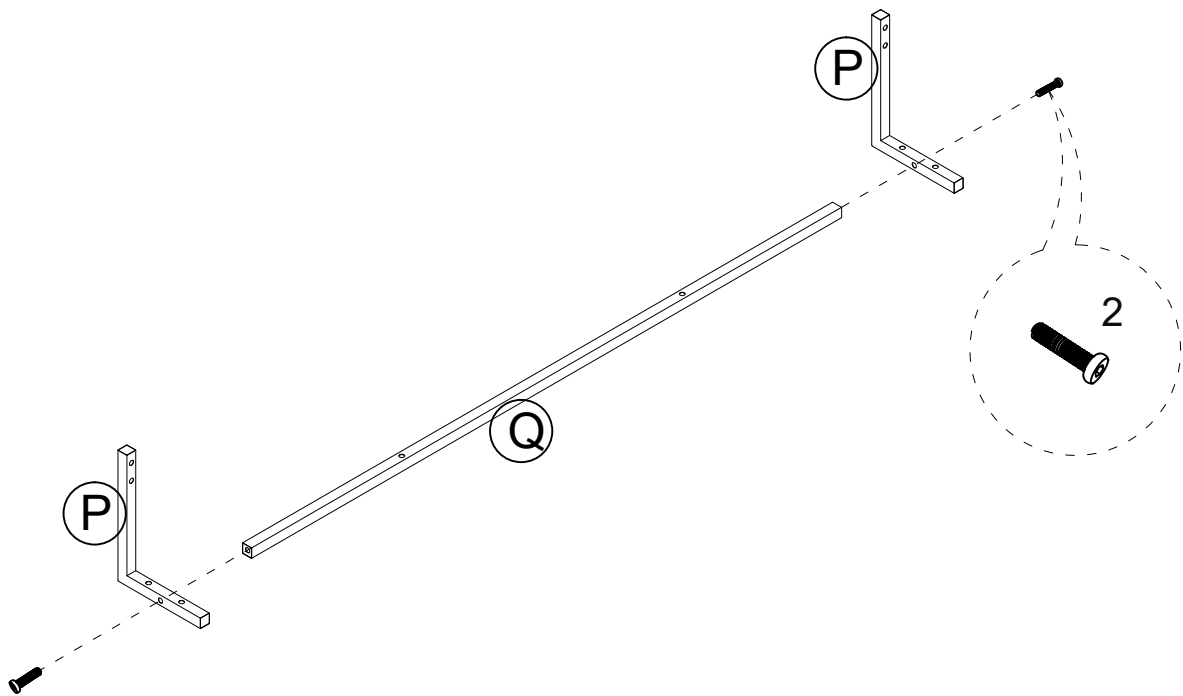

2 x6

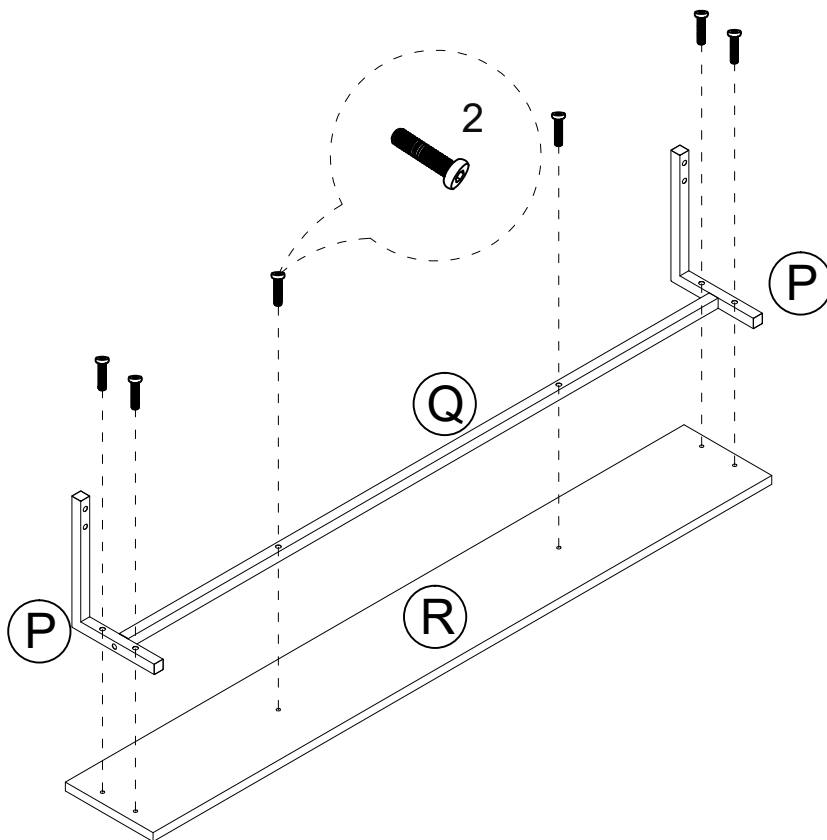

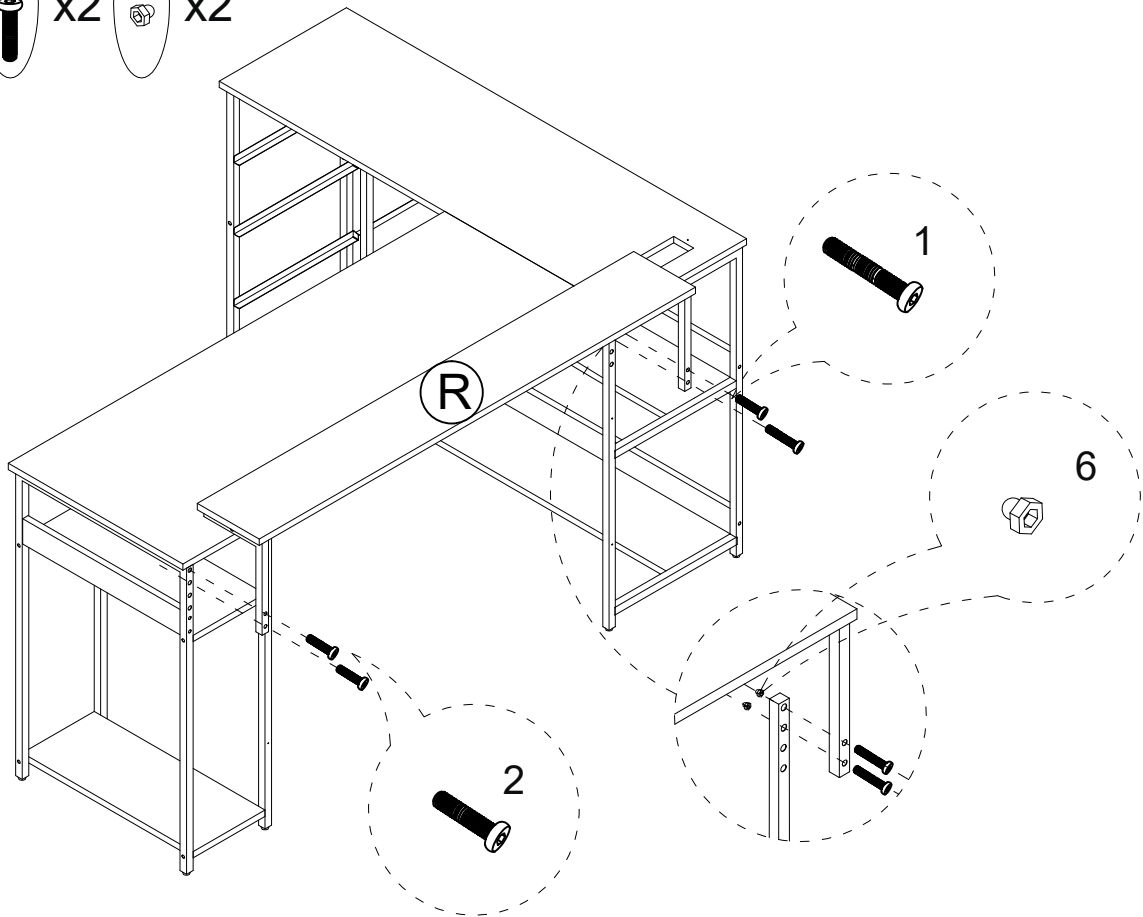
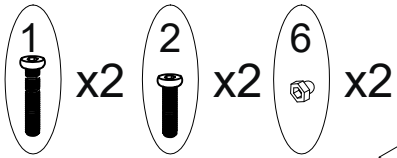

EN_ THE HEIGHT OF THE TOP PLATE CAN BE ADJUSTED ACCORDING TO THE HOLE POSITIONS ON THE TABLE LEGS.

FR_ LA HAUTEUR DU PLATEAU SUPÉRIEUR PEUT ÊTRE RÉGLÉE EN FONCTION DES ORIFICES DES PIEDS DE TABLE.

ES_ LA ALTURA DE LA TABLA SUPERIOR SE PUEDE AJUSTAR SEGÚN LOS ORIFICIOS DE LAS PATAS DE LA MESA.

DE_ DIE HÖHE DER ARBEITSPLATTE KANN ANHAND DER BOHRUNGEN IN DEN TISCHBEINEN ANGEPAßt WERDEN.

IT_ L'ALTEZZA DEL PIANO SUPERIORE PUÒ ESSERE REGOLATA IN BASE AI FORI DELLE GAMBE DEL TAVOLO.

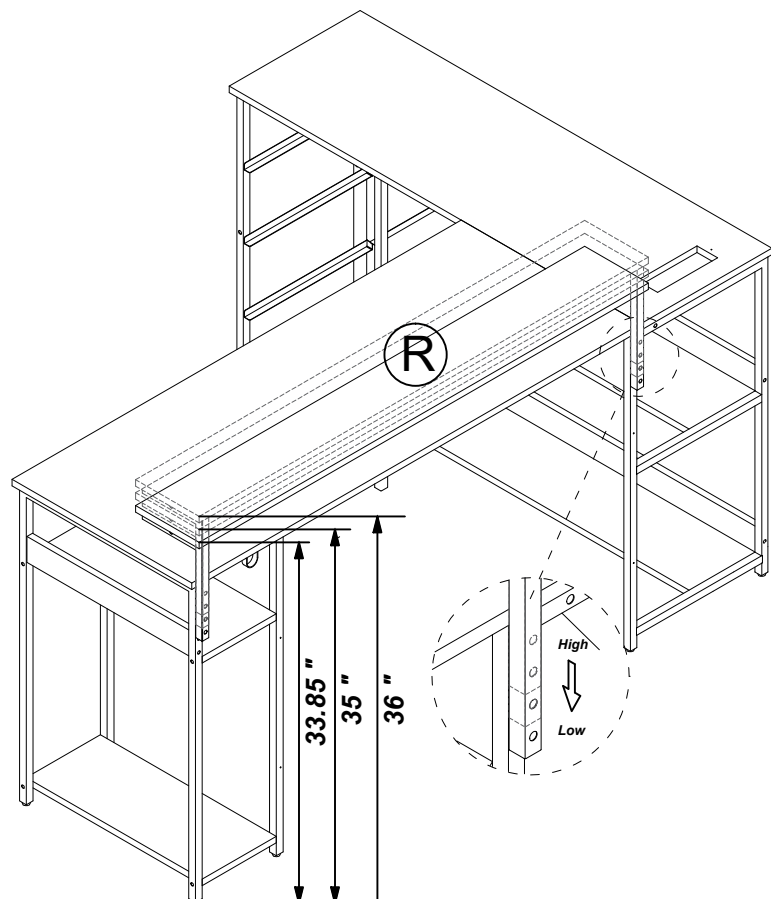

- 3 x5
- 6 x1

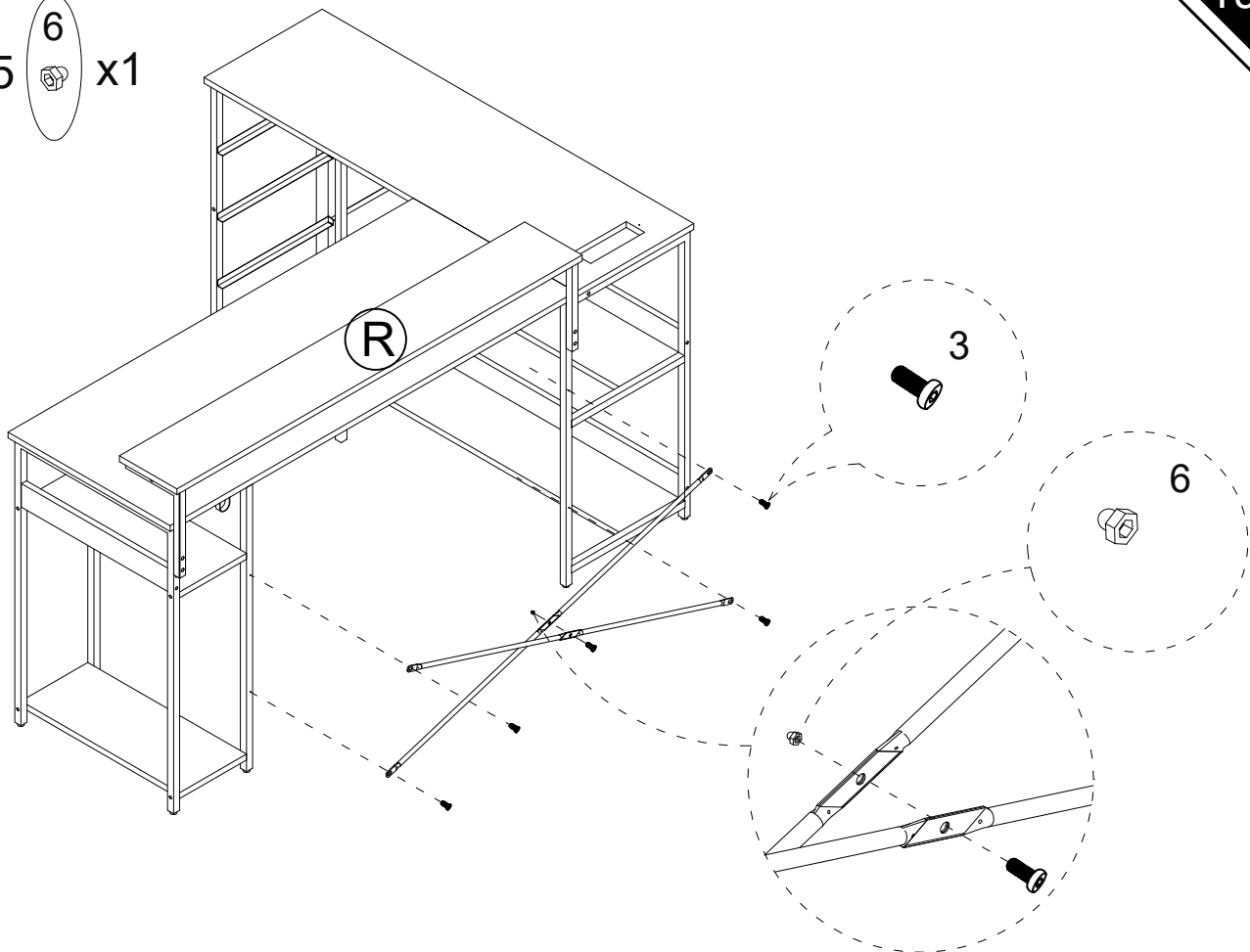

- 5 x2
- 7 x1

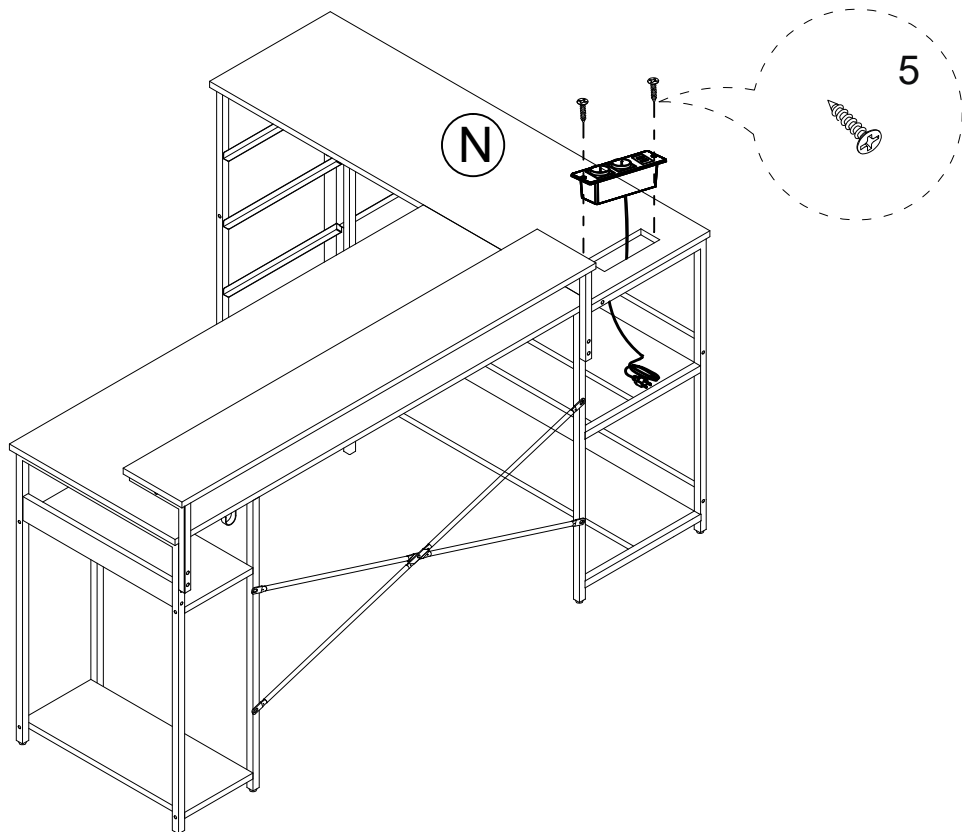



x8



x4

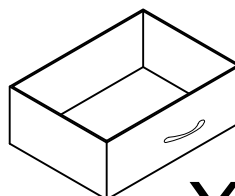
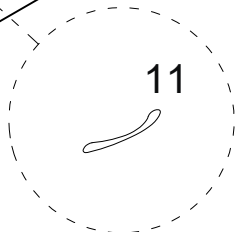
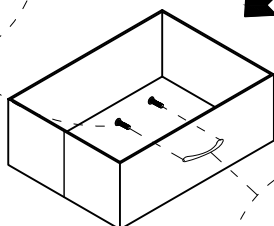
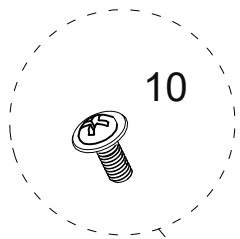
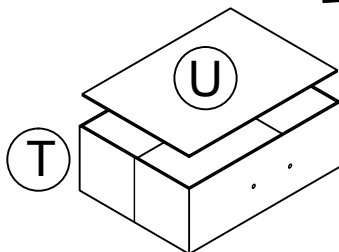
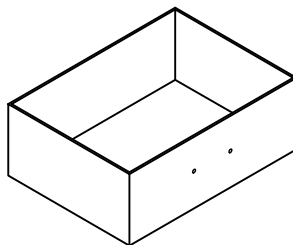
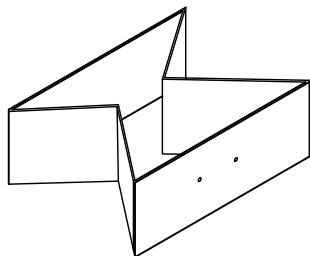

X4

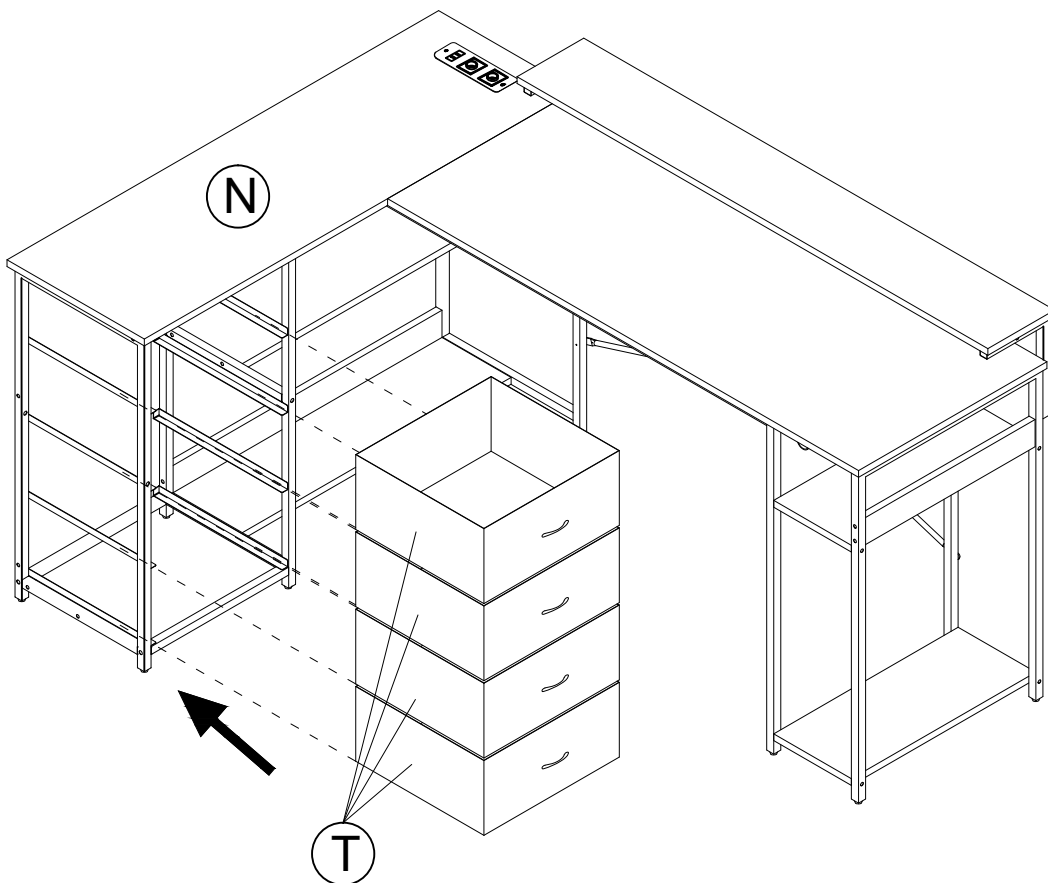

9

x2

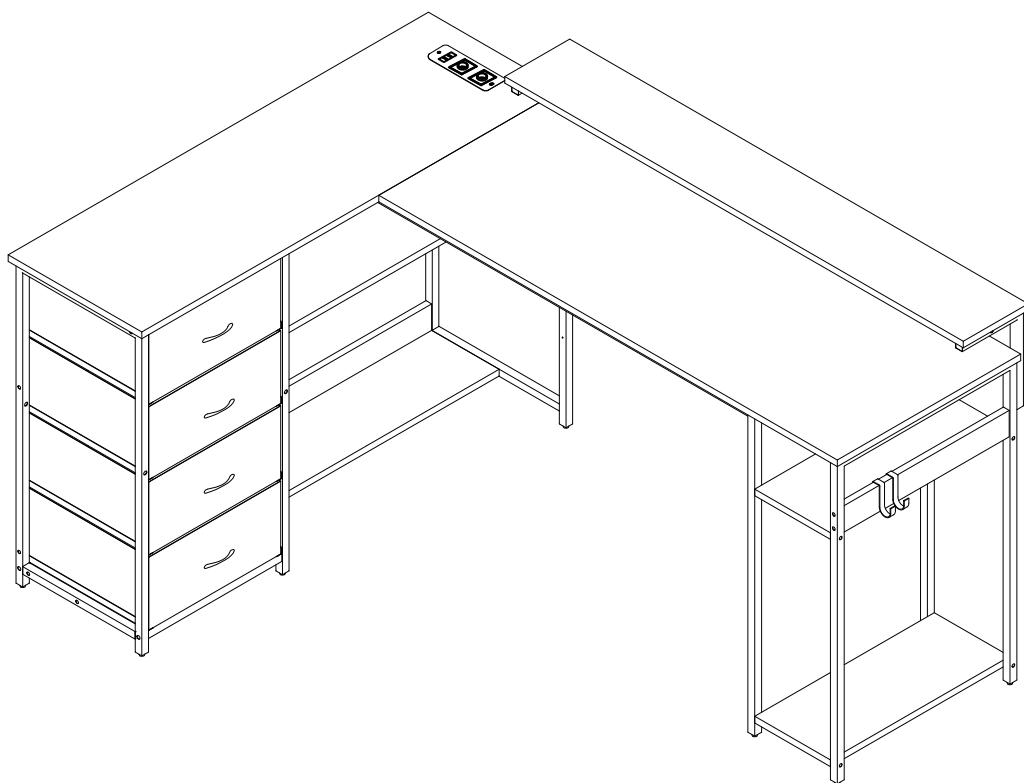
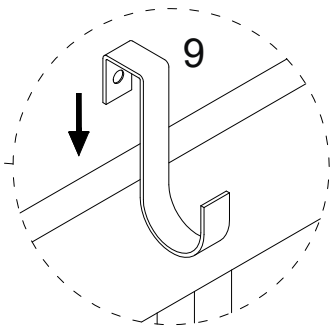
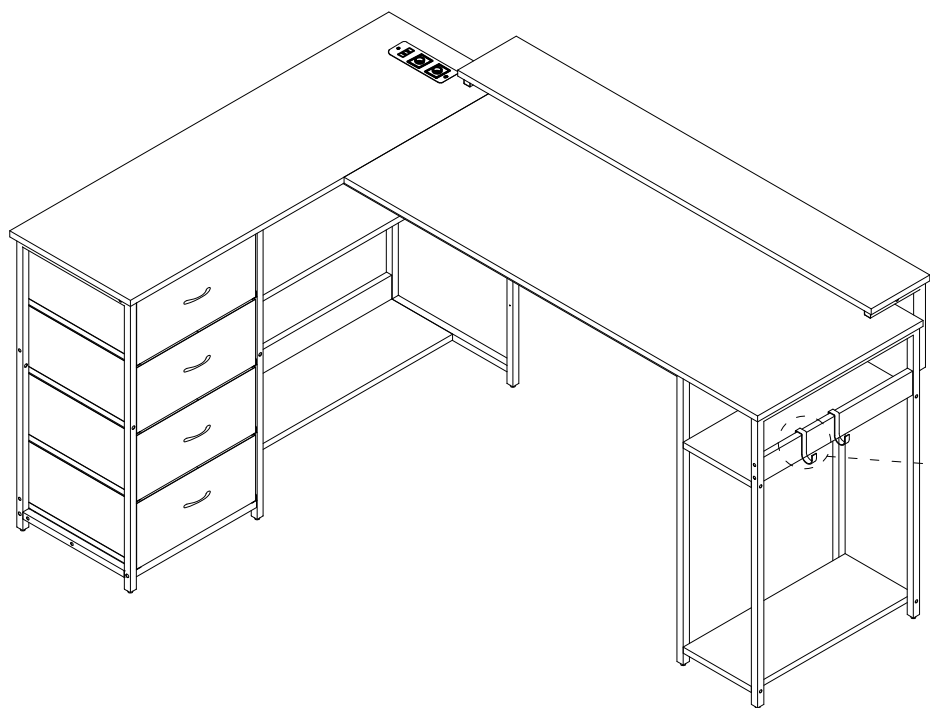

If you have any questions, please contact our customer care center, Our contact details are below:

US

 001-877-644-9366

 customerservice@aosom.com

Imported by Aosom LLC
27150 SW Kinsman Rd Wilsonville, OR 97070 USA
MADE IN CHINA

If you have any questions, please contact our customer care center, Our contact details are below:

CA

 416-792-6088

 customerservice@aosom.ca

Imported by Aosom Canada Inc.
7270 Woodbine Avenue, Unit 307, Markham,
Ontario Canada L3R 4B9
MADE IN CHINA

Si vous avez la moindre question, veuillez contacter notre centre d'assistance à la clientèle, Nos coordonnées sont les suivantes:

 416-792-6088

 customerservice@aosom.ca

Importé par Aosom Canada Inc.
7270 Woodbine Avenue, unité 307,
Markham, Ontario Canada L3R 4B9
FABRIQUÉ EN CHINE

If you have any questions, please contact our customer care center, Our contact details are below:

UK

 0044-800-240-4004

 enquiries@mhstar.co.uk

IMPORTER ADDRESS:
MH STAR UK LTD
Unit 27, Perivale Park,
Horsenden lane South
Perivale, UB6 7RH
MADE IN CHINA

Si vous avez la moindre question, veuillez contacter notre centre d'assistance à la clientèle, Nos coordonnées sont les suivantes:

 0033-1-84166106

 aosom@mhfrance.fr

Importé par/Fabricant/REP:
MH FRANCE
2 Rue Maurice Hartmann
92130 Issy Les Moulineaux
France
FABRIQUÉ EN CHINE

Wenn Sie Fragen haben, wenden Sie sich bitte an unser Kundendienstzentrum, Unsere Kontaktdaten stehen unten:

DE

 0049-0(40)-87408465

 service@aosom.de

ADRESSE DES IMPORTEURE/Hersteller/REP:
MH Handel GmbH
Wendenstraße 309
D-20537 Hamburg
Germany
IN CHINA HERGESTELLT

In caso di dubbio, si prega di contattare il nostro centro assistenza clienti, I nostri dettagli di contatto sono di seguito:

IT

 0039-0249471447

 clienti@aosom.it

IMPORTATO DA/Produttore/REP:
AOSOM Italy srl
Centro Direzionale Milanofiori
Strada 1 Palazzo F1
20057 Assago (MI)
P.I.: 08567220960
FATTO IN CINA

Si tiene alguna pregunta, comuníquese con nuestro Centro de Atención al Cliente, Nuestros datos de contacto son los siguientes:

ES

 0034-931294512

 atencioncliente@aosom.es

IMPORTADOR/Fabricante/REP:
SPANISH AOSOM, S.L.
C/ROC GROS, N°15.08550, ELS HOSTALETES DE
BALENYÀ, SPAIN.
B66295775
HECHO EN CHINA

Se tiver alguma dúvida, por favor contacte o nosso Centro de Atendimento ao Cliente, Os nossos dados de contacto são os seguintes:

 0034-931294512

 info@aosom.pt.

IMPORTADOR/Fabricante/REP:
SPANISH AOSOM, S.L.
C.ROC GROS N.15, 08550. ELS HOSTALETES DE
BALENYÀ
FEITO NA CHINA

Si vous avez la moindre question, veuillez contacter notre centre d'assistance à la clientèle, Nos coordonnées sont les suivantes:

FR

 0033-1-84166106

 aosom@mhfrance.fr

Importé par/Fabricant/REP:
MH FRANCE
2 Rue Maurice Hartmann
92130 Issy Les Moulineaux
France
FABRIQUÉ EN CHINE



FR

Cet appareil, ses accessoires, cordons et batteries se recyclent

REPRISE À LA LIVRAISON



OU

À DÉPOSER EN MAGASIN



OU

À DÉPOSER EN DÉCHÈTERIE



Points de collecte sur www.quefairedemesdechets.fr
Privilégiez la réparation ou le don de votre appareil !