

# AIYAPLAY

IN250700357V02\_UK\_FR\_DE\_ES\_IT

**370-448V00**

## **PEDAL GO-KART / KART À PÉDALES / PEDAL-GOKART / KARTING DE PÉDALES / GO-KART A PEDALI**

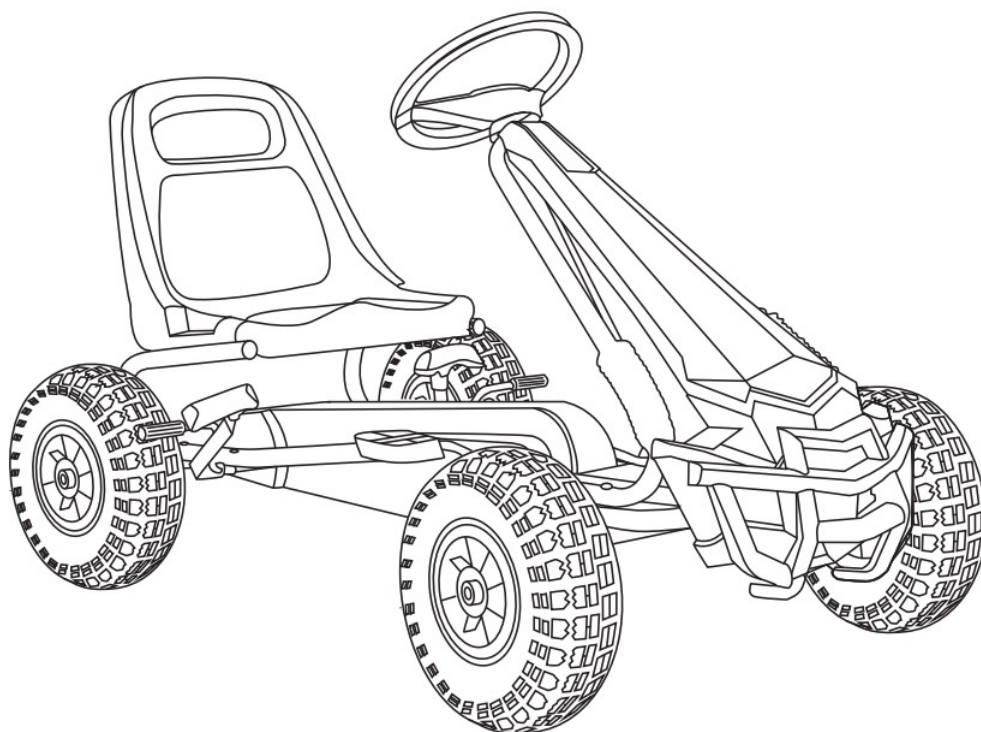

**EN\_WARNING:** Suitable for children of 36 months+; Max weight: 30 kg.

**FR\_ATTENTION:** Convient aux enfants de 36 mois+; Poids maximum : 30 kg.

**DE\_ACHTUNG:** Geeignet für Kinder im Alter von 36 Monate+; Max. Gewicht: 30 kg.

**ES\_ADVERTENCIA:** Adecuado para los niños de 36 meses+; Peso máximo: 30 kg.+

**PT\_ADVERTÊNCIA:** Adequado para crianças de 36 meses+; Peso máximo: 30 kg.

**IT\_AVVERTENZA:** Adatto a bambini di 36 mesi+; Peso massimo: 30 kg.

**EN\_IMPORTANT, RETAIN FOR FUTURE REFERENCE: READ CAREFULLY.**

**FR\_IMPORTANT : A LIRE ATTENTIVEMENT ET A CONSERVER POUR VOUS Y REFERER  
ULTERIEUREMENT**

**ES\_IMPORTANTE, LEA Y GUARDE PARA FUTURAS REFERENCIAS.**

**DE\_WICHTIG! SORGFÄLTIG LESEN UND FÜR SPÄTER NACHSCHLAGEN AUFBEWAHREN.**

**IT\_IMPORTANTE! CONSERVARE IL PRESENTE MANUALE PER FUTURO RIFERIMENTO E  
LEggerlo ATTENTAMENTE.**

# Parts List (included)

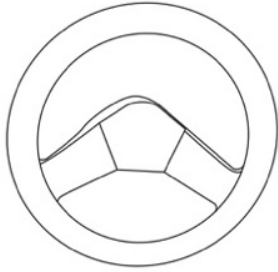

1. Steering wheel \*1



2. Seat\*1



3. Steering shaft \*1  
(Included  
3x rubber washer,  
1xM8x16mm washer,  
2x steel square washer,  
1x spring washer,  
1xM8 nut)

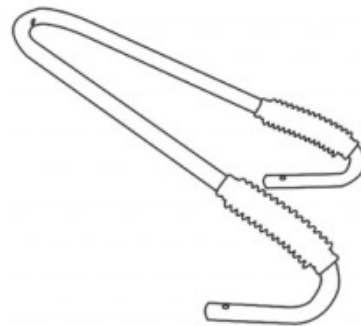

4. Steering support\*1



5. Manual

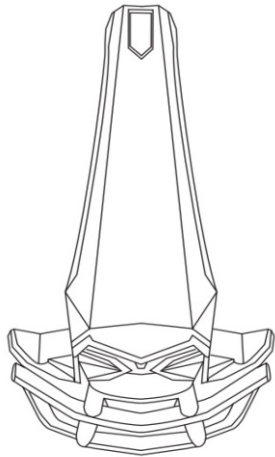

6. Front panel\*1

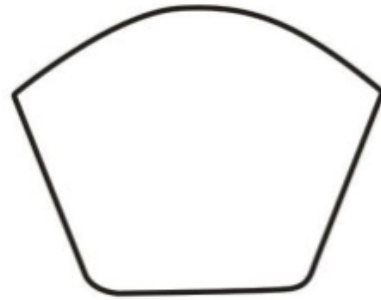

7. Steering Wheel Cover\*1

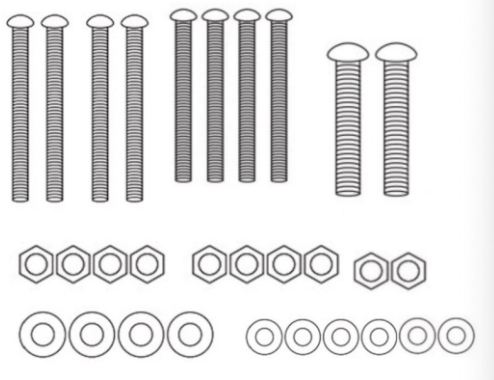

8. Bag of nuts and bolts:  
2 x M5\*35mm bolts,  
4 x M5\*40mm bolts,  
4 x M5\*45mm bolts,  
6 x M5\*12 washers,  
4 x M5\*14 washers,  
10x M5 nuts

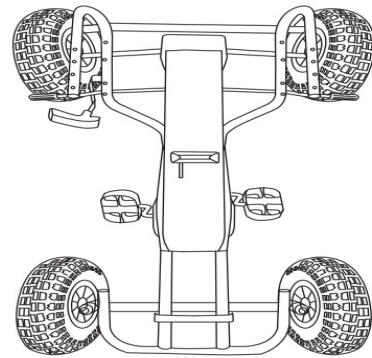

9. Go kart body

# Assembly Instructions:

1. Attach the steering support to the go kart body. Fix with M5x45mm \*4pcs bolts and ensure to use dia M5x12mm\*4pcs washers and M5 nut \*4pcs where appropriate.

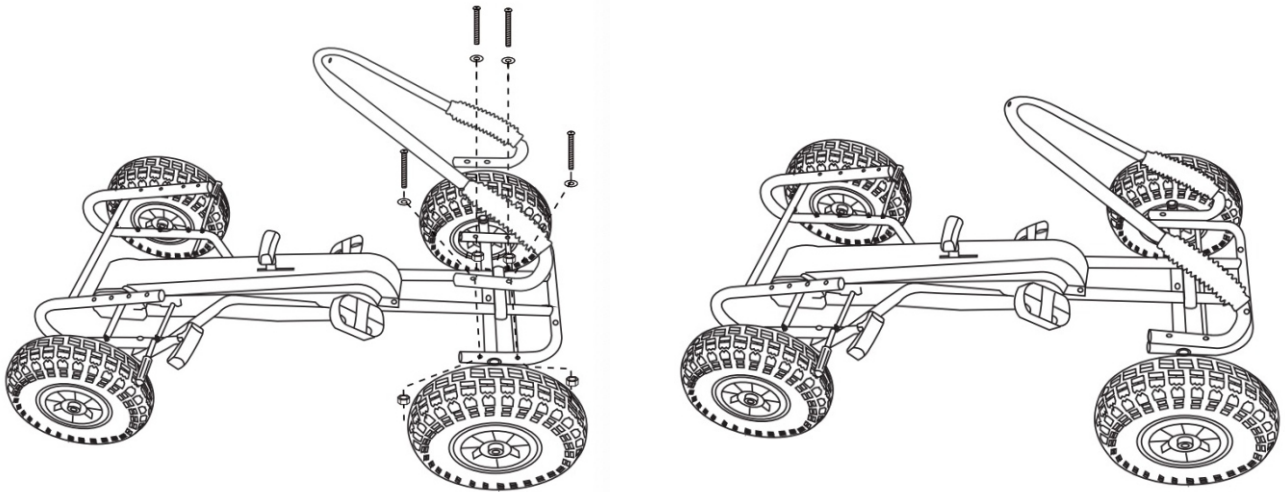

2. Assemble the steering shaft:

Remove the nut and washers from the steering shaft. Insert a metal washer into the steering shaft.

Insert the steering shaft with the metal from the bottom to the go kart body. The hook of the steering shaft should go into the triangle area of the steering linkage. the steering shaft pass through the go kart body then through the steering support tube.

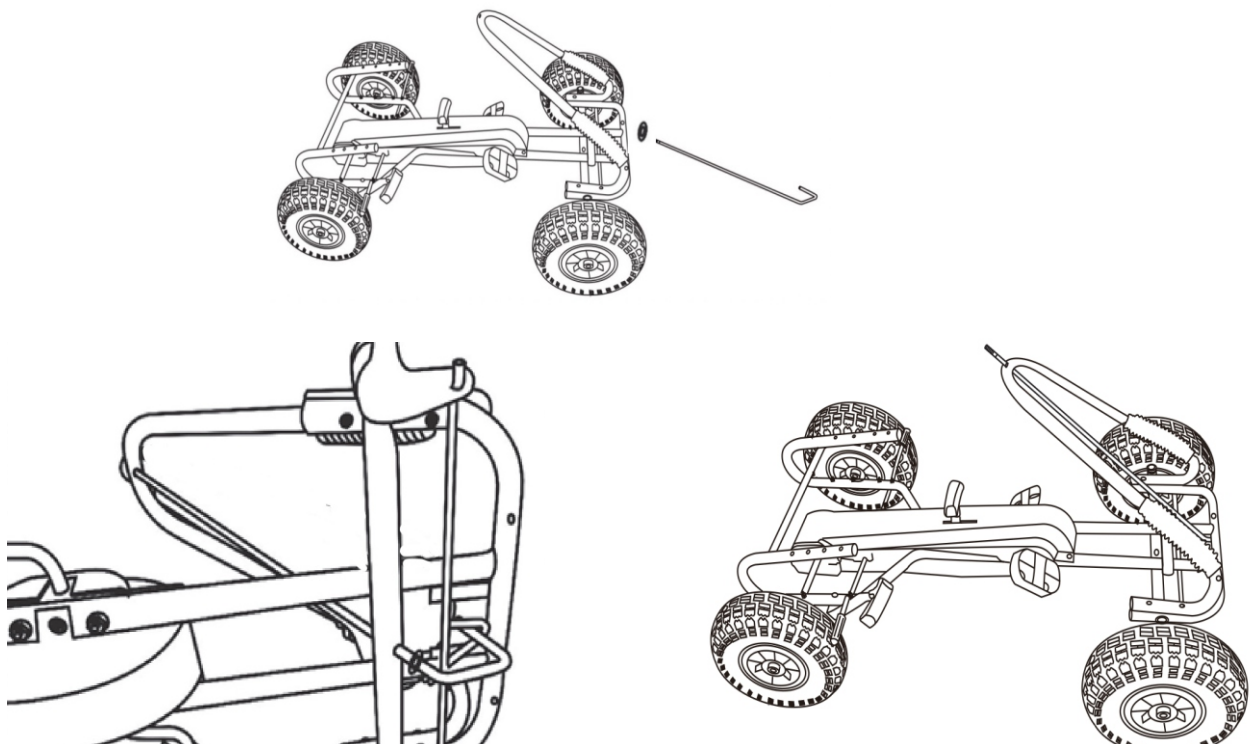

3. Put the plant panel on the front of the go-kart .

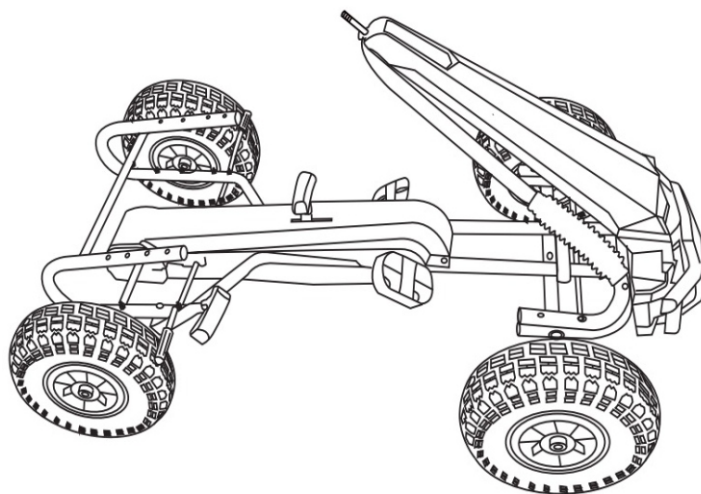

4. On the Steering shaft, insert 2 rubber washers (The rubber washer is used to adjust the length, use 1-3pcs for you to adjust). Add a square washer at the bottom of the steering wheel., then insert the steering wheel. Insert another square washer to sit inside the top of the steering wheel, followed by a spring washer. Secure all into place with an M8 nut.

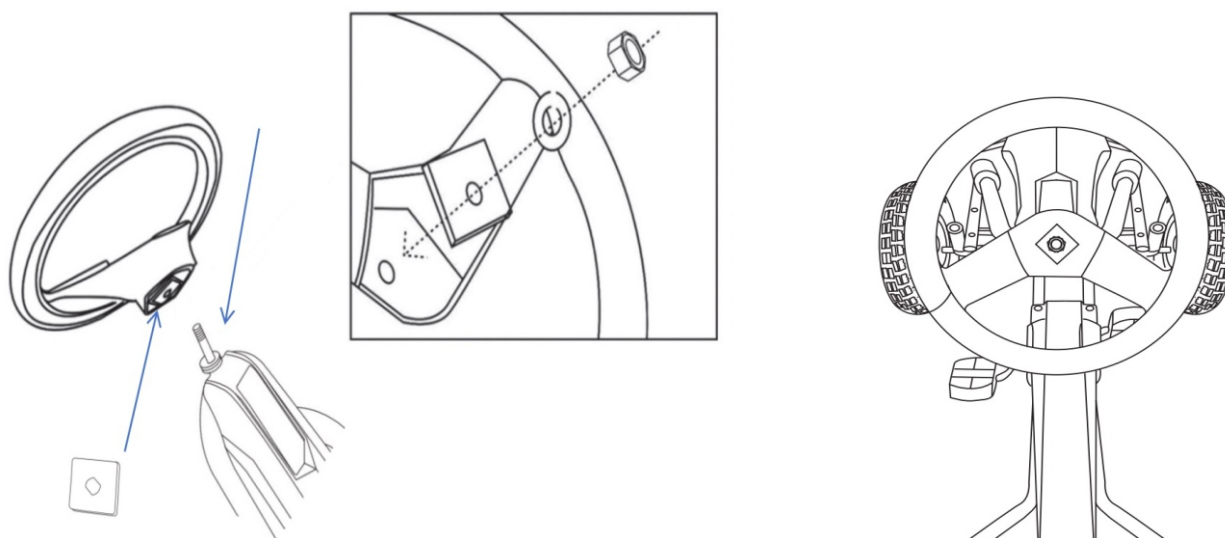

5. Assemble the plant panel:

Fix with M5x35mm \*2pcs bolts and ensure to use dia M5x12mm\*2pcs washers and M5 nut \*2pcs where appropriate.

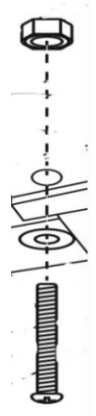
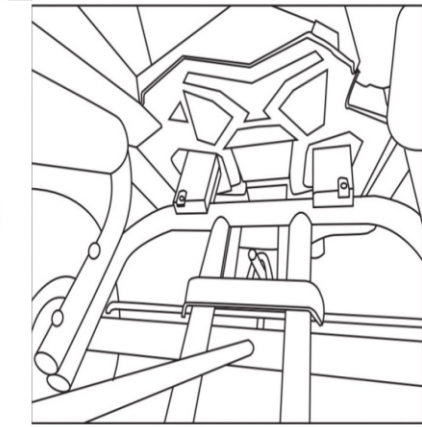
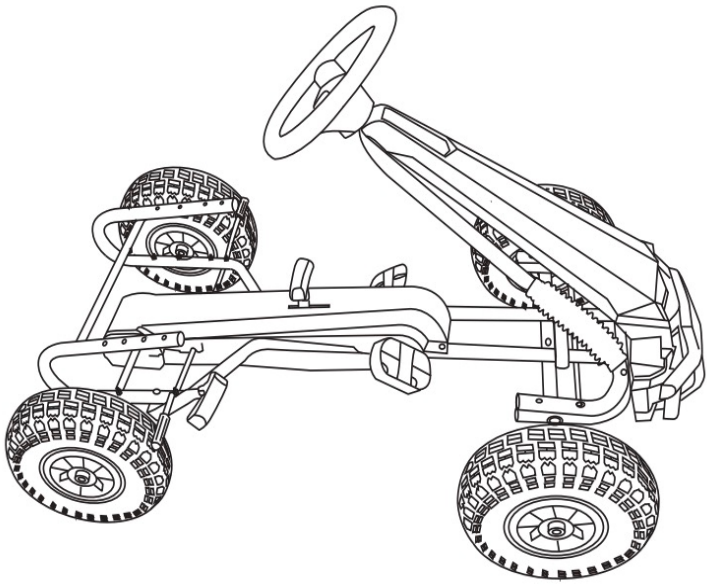

6. . Place the steering wheel cover in the center of the steering wheel.



7. Fix the seat to the go kart body using M5x40mm\*4pcs bolts, ensure to use dia M5x14mm\*4pcs washers and M5 nut\*4pcs again where appropriate.

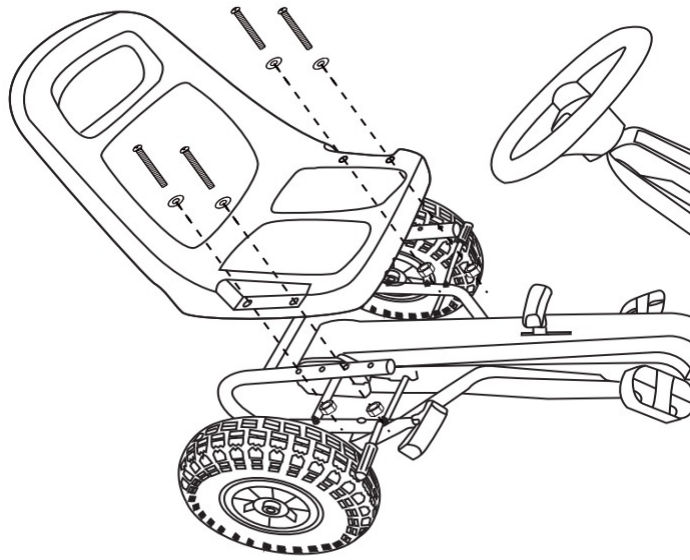

8. Ensure all nuts and bolts are securely tightened before use, and the tyres are appropriately inflated.

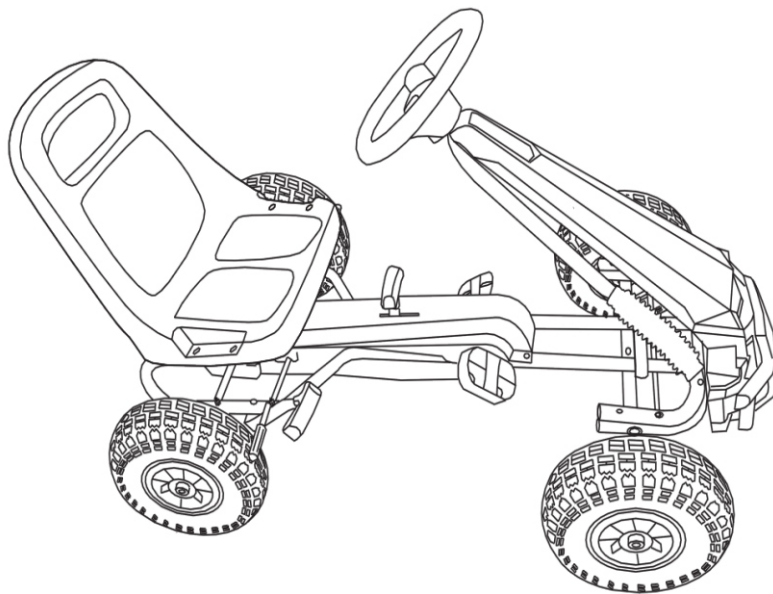

## **WARNINGS:**

1. CHOKING HAZARD—Small parts. Not suitable for children under 3 years.
2. Only allowed for adults to install, keep children away.
3. Children should ride this on flat and smooth surface, and should keep away from traffic road; Strictly prohibited in nearby motor vehicles, streets, steps, slopes, hills, roads, alleys, swimming pools or other places with water;
4. This product shall be used under the custody of adults and shall wear shoes;
5. This product is only limited to one-person ride.
6. Adult assembly and installation of all parts are required.
7. Do not let Children playing alone with this product prevent from danger of Falling.
8. The toy should be used with caution since skill is required to avoid falls or collisions causing injury to the user or third parties.
9. Ensure this product is properly assembled before using.

### **MAINTENANCE & CARE**

- A. Keep all instructions and parts relating to this product for future reference.
- B. Regularly check for damage and that all screws are securely tightened.
- C. Check that the seat is securely fastened.
- D. Cleanness: Wipe clean with dry cloth on surface only.
- E. Storage: keep away from fire, damp and other high temperature area. Avoid direct Sun exposure.

## **Material of products:**

A、(PP) B、(IRON)

# Liste des pièces (incluses)

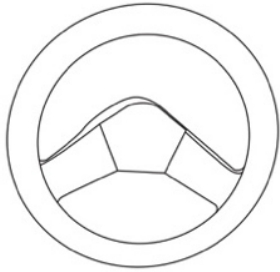

1. Volant\*1



2. Siège \*1



3. Colonne de direction\*1  
(incluant  
3x rondelle en caoutchouc,  
1xM8x16mm rondelle,  
2x rondelle carrée en acier,  
1x rondelle élastique,  
1xM8 écrou)

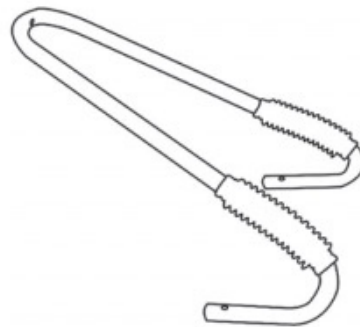

4. Support de direction \*1



5. Manuel

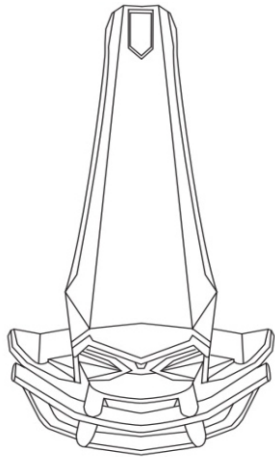

6. Panneau avant \*1

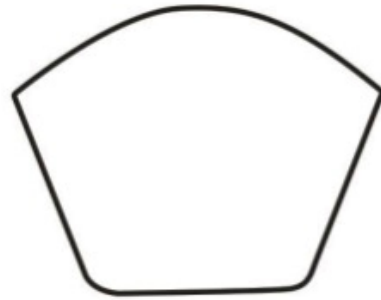

7. Couvre-volant \*1

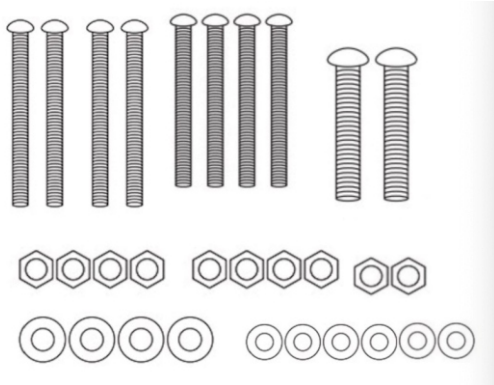

8. Sachet d'écrous et boulons:  
2 x Boulons M5 35 mm,  
4 x Boulons M5 40 mm,  
4 x Boulons M5\* 45 mm,  
6 x Rondelles M512,  
4 x Rondelles M514,  
10 écrous M5

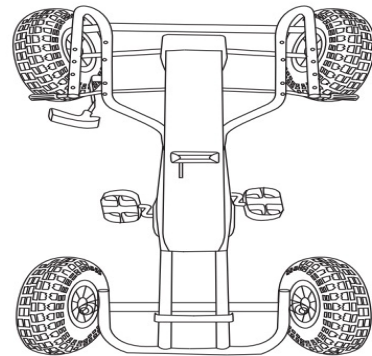

9. Châssis de kart

# Instructions d'assemblage :

1. Fixez le support de direction au châssis du kart. Fixez avec 4 boulons M5x45mm et veillez à utiliser des rondelles dia M5x12mm\*4 et 4 écrous M5 si nécessaire.

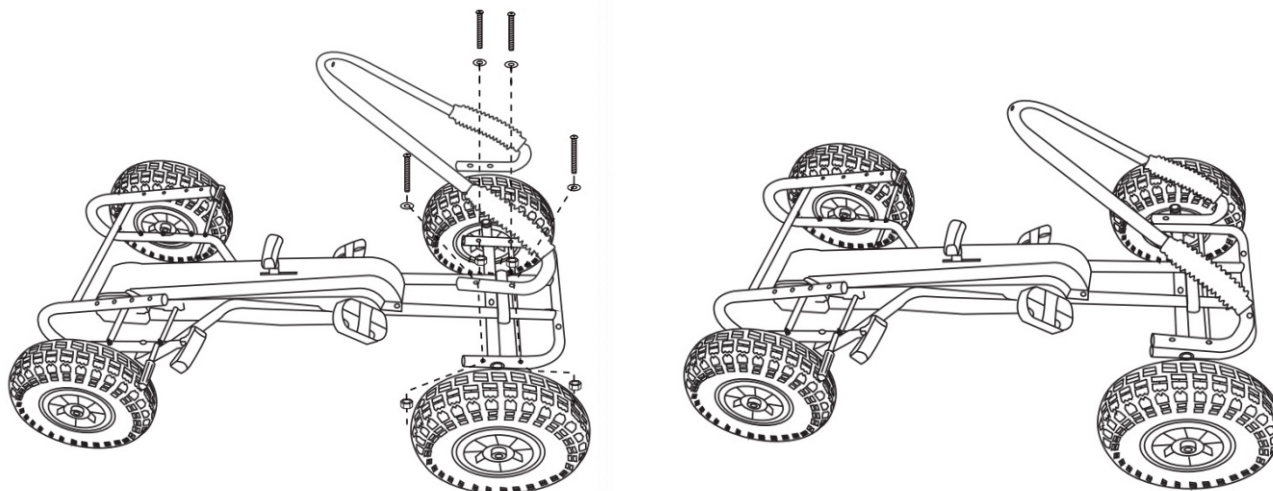

2. Assembler l'arbre de direction :

Retirez l'écrou et les rondelles de l'arbre de direction. Insérez une rondelle métallique dans l'arbre de direction.

Insérez l'arbre de direction avec la partie métallique depuis le bas vers le châssis du kart. Le crochet de l'arbre de direction doit s'engager dans la zone triangulaire de la biellette de direction. L'arbre de direction traverse d'abord le châssis du kart, puis le tube de support de direction.

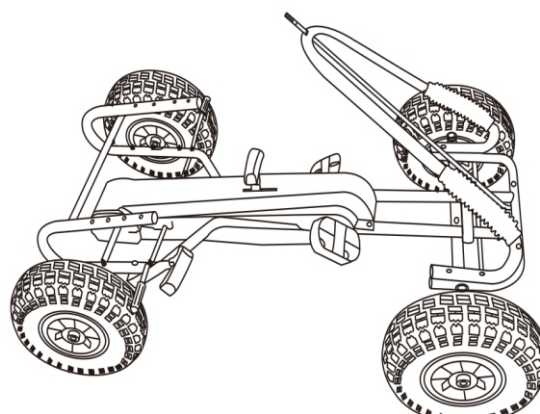
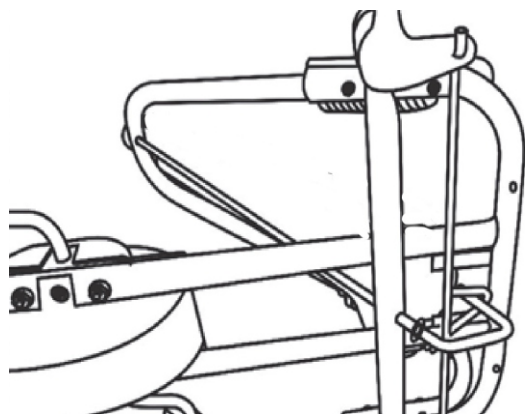
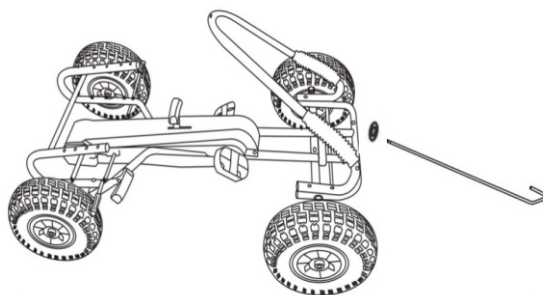

3. Placez le panneau végétal à l'avant du kart.

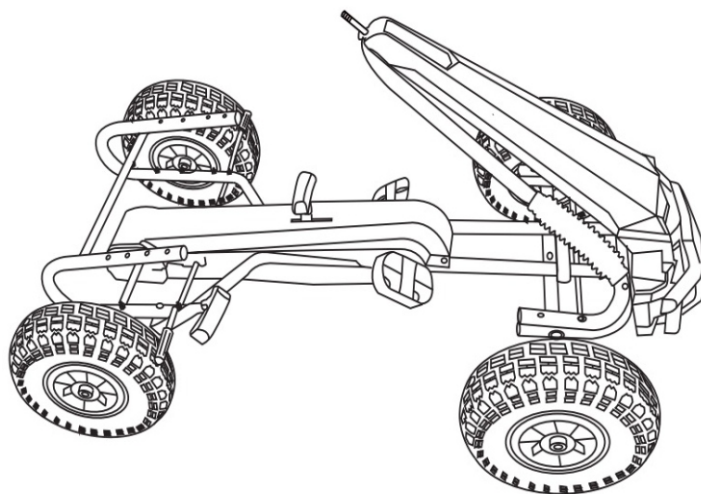

4. Sur l'arbre de direction, insérez 2 rondelles en caoutchouc (la rondelle en caoutchouc sert à ajuster la longueur, utilisez 1-3 pièces pour votre réglage). Ajoutez une rondelle carrée au bas du volant, puis insérez le volant. Insérez une autre rondelle carrée à l'intérieur du haut du volant, suivie d'une rondelle ressort. Fixez le tout avec un écrou M8.

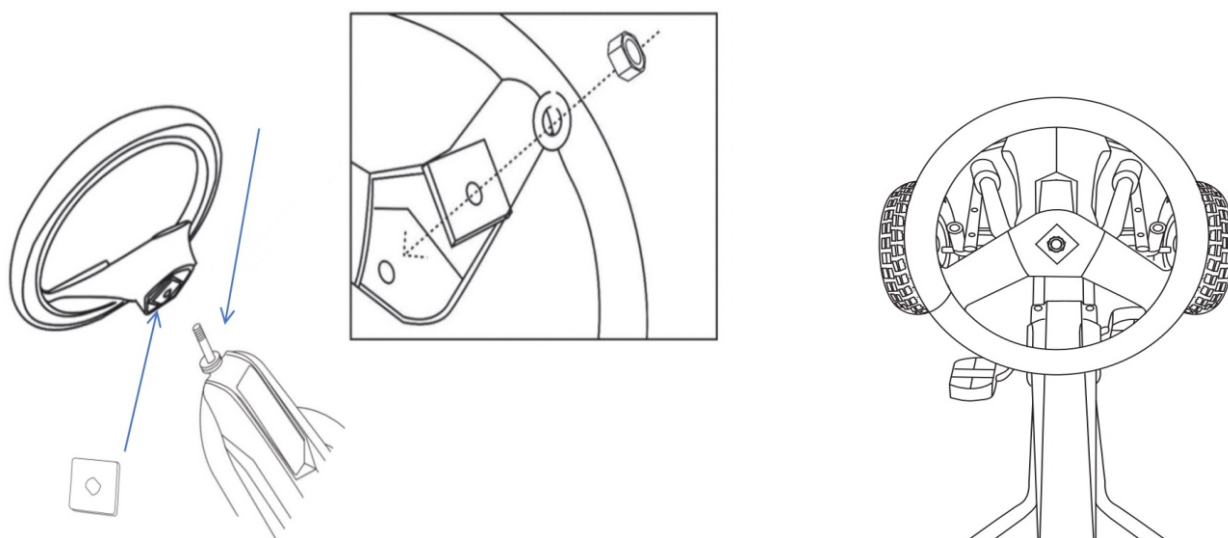

5. Assemblage du panneau végétal :

Fixez avec des boulons M5x35mm \*2 pièces et assurez-vous d'utiliser des rondelles M5x12mm \*2 pièces et des écrous M5 \*2 pièces là où c'est approprié.

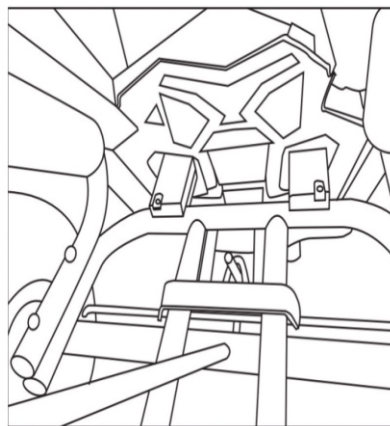
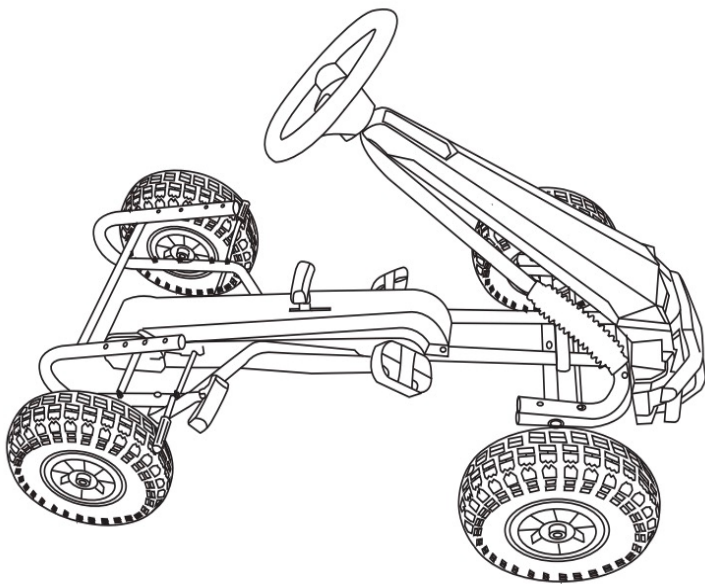

6. Placer le cache volant au centre du volant.



7. Fixez le siège au châssis du kart à l'aide de 4 boulons M5x40mm, en veillant à utiliser 4 rondelles M5x14mm et 4 écrous M5 aux endroits appropriés.

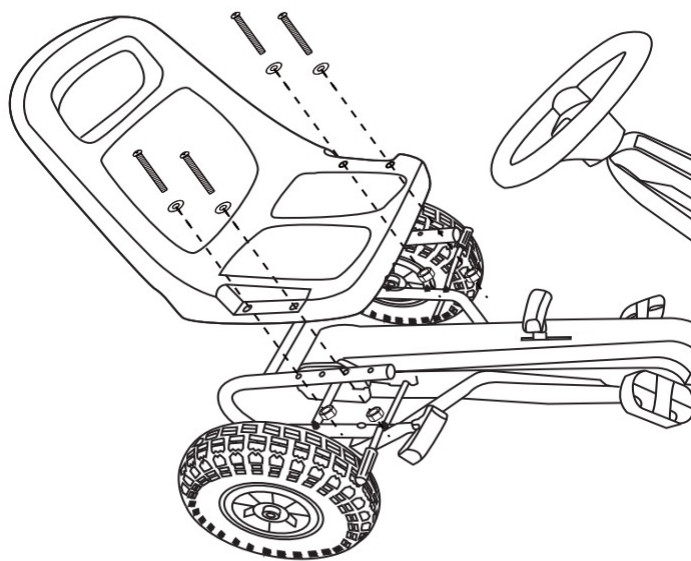

8. Vérifiez que tous les écrous et boulons sont bien serrés avant utilisation et que les pneus sont correctement gonflés.

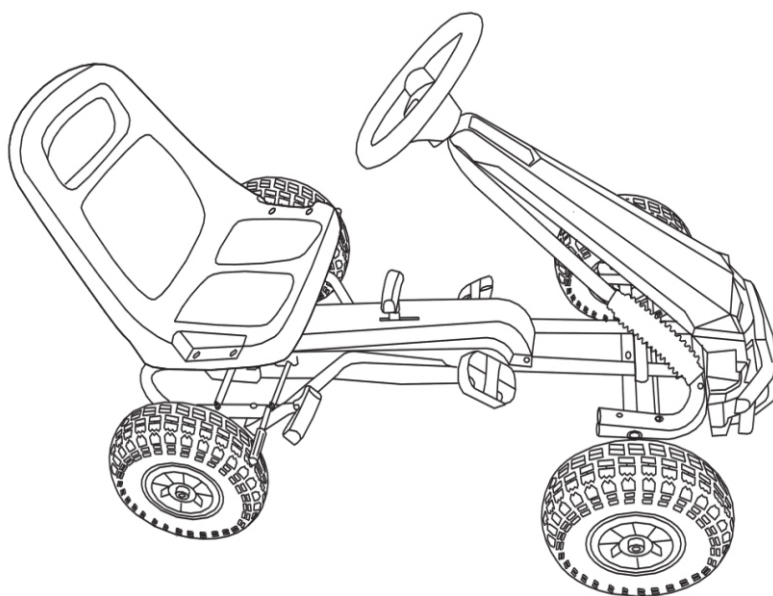

## **ATTENTION:**

1. DANGER D'ÉTOUFFEMENT—Petits éléments. Ne convient pas aux enfants de moins de 3 ans.
2. Installation par des adultes uniquement, tenir les enfants à l'écart.
3. Les enfants doivent utiliser ce produit sur une surface plate et lisse, et doivent s'éloigner des routes de circulation ; Il est strictement interdit de l'utiliser à proximité de véhicules motorisés, de rues, d'escaliers, de pentes, de collines, de routes, d'allées, de piscines ou d'autres endroits avec de l'eau.
4. Ce produit doit être utilisé sous la surveillance d'adultes et doit être porté avec des chaussures.
5. Ce produit est limité à une seule personne.
6. L'assemblage et l'installation de toutes les pièces doivent être effectués par un adulte.
7. Ne laissez pas les enfants jouer seuls avec ce produit pour éviter les chutes.
8. Le jouet doit être utilisé avec prudence car des compétences sont nécessaires pour éviter les chutes ou les collisions pouvant causer des blessures à l'utilisateur ou à des tiers.
9. Assurez-vous que ce produit est correctement assemblé avant de l'utiliser.

### **ENTRETIEN ET MAINTENANCE**

- A. Conservez toutes les instructions et les pièces relatives à ce produit pour pouvoir vous y référer ultérieurement.
- B. Vérifiez régulièrement que le produit n'est pas endommagé et que toutes les vis sont bien serrées.
- C. Vérifier que le siège est bien fixé.
- D. Propreté: Essuyer uniquement la surface avec un chiffon sec.
- E. Stockage: Tenez à l'écart du feu, de l'humidité et d'autres zones à haute température. Éviter une exposition directe au soleil.

## **Matériau des produits :**

A、(PP) B、(IRON)

# Teileliste (im Lieferumfang enthalten):

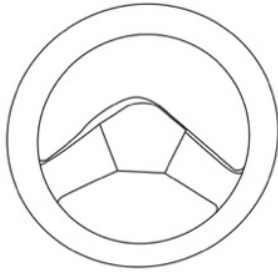

1. Lenkrad \*1



2. Sitz \*1



3. Lenkwelle \*1  
(Enthält  
3x Gummischeibe,  
1xM8x16mm Scheibe,  
2x Stahl-Vierkantscheibe,  
1x Federring,  
1xM8 Mutter)

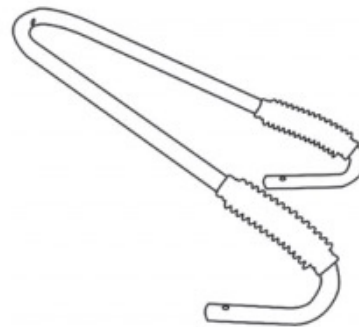

4. Lenkstütze\*1



5. Handbuch

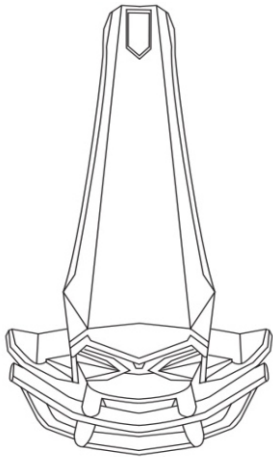

6. Frontplatte\*1

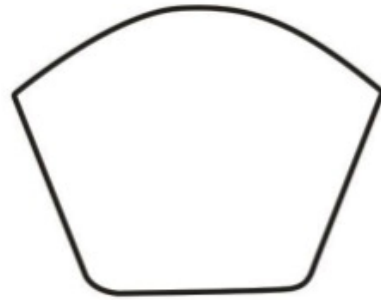

7. Lenkradabdeckung\*1

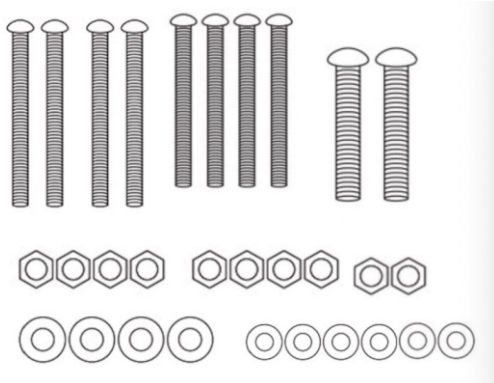

8. Beutel mit Muttern und Schrauben:

2 x M5\*35 mm Schrauben,  
4 x M5\*40 mm Schrauben,  
4 x M5\* 45 mm Schrauben,  
6 x M5\*12 Unterlegscheiben,  
4 x M5\*14 Unterlegscheiben,  
10x M5 Muttern

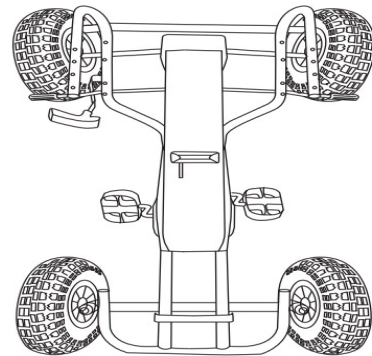

9. Go-Kart-Karosserie

# Montageanleitung:

1. Befestigen Sie die Lenkstütze am Go-Kart-Chassis. Verwenden Sie dazu 4 Stück M5x45mm-Schrauben und jeweils 4 Stück M5x12mm-Scheiben sowie 4 Stück M5-Muttern, wo erforderlich.

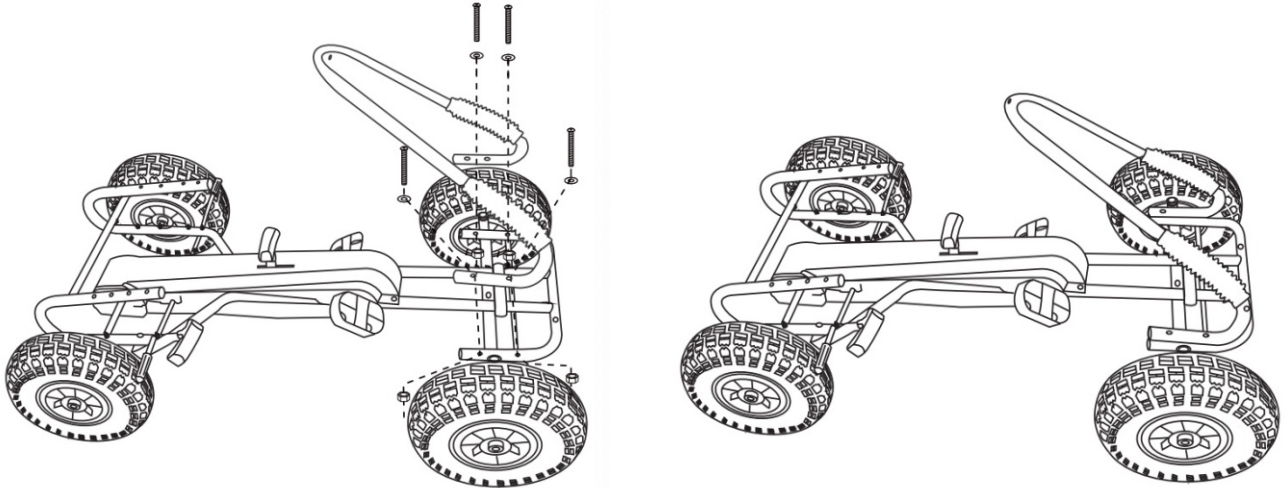

2. Montieren Sie die Lenkwelle:

Entfernen Sie die Mutter und die Unterlegscheiben von der Lenkwelle. Setzen Sie eine Metallunterlegscheibe auf die Lenkwelle.

Führen Sie die Lenkwelle mit der Metallunterlegscheibe von unten in den Go-Kart-Rahmen ein. Der Haken der Lenkwelle sollte in den dreieckigen Bereich der Lenkstange greifen. Die Lenkwelle verläuft durch den Go-Kart-Rahmen und dann durch das Lenkstützrohr.

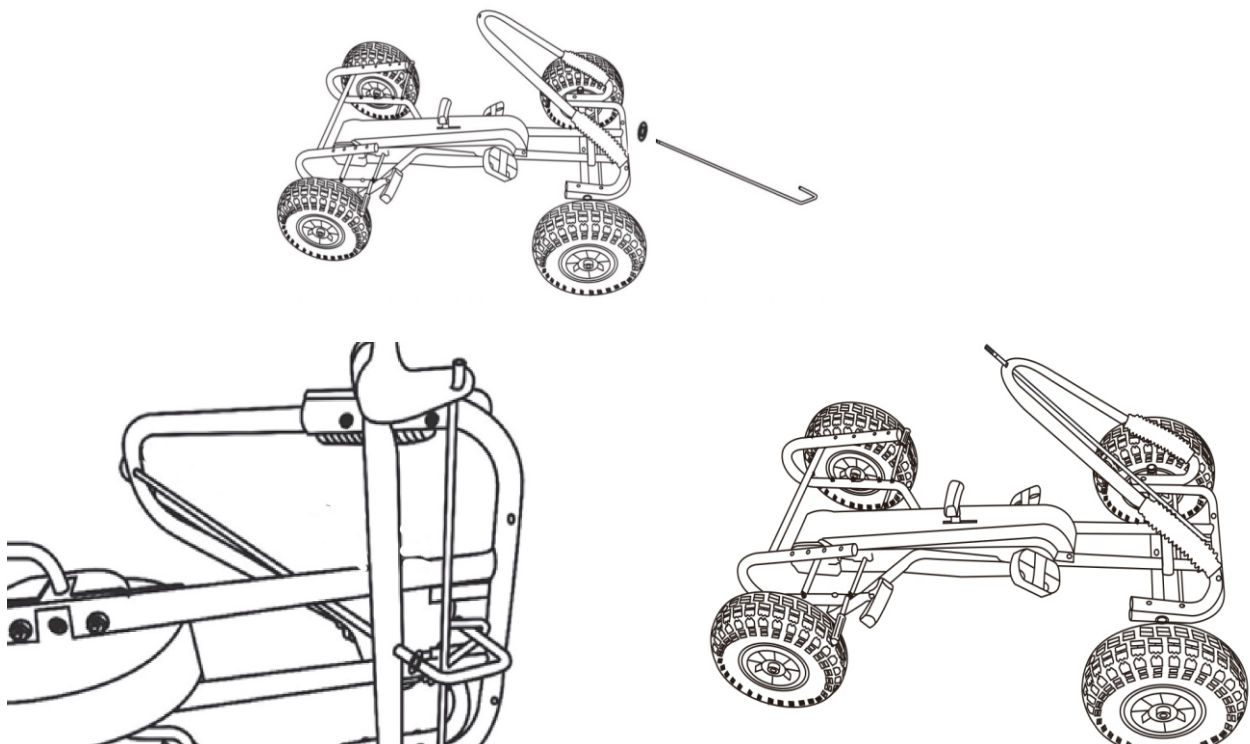

3. Befestigen Sie die Pflanzenplatte an der Vorderseite des Go-Karts.

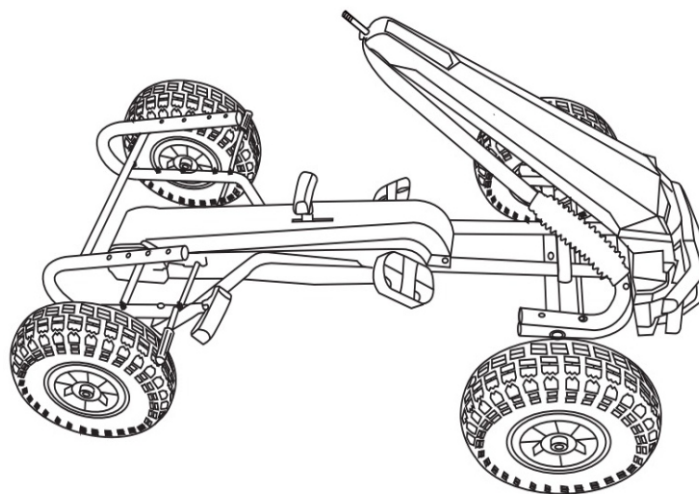

4. Auf der Lenkachse zwei Gummischeiben einsetzen (Die Gummischeibe dient zur Längeneinstellung, verwenden Sie 1-3 Stück zur Einstellung). Fügen Sie eine quadratische Unterlegscheibe unter dem Lenkrad hinzu, dann setzen Sie das Lenkrad ein. Fügen Sie eine weitere quadratische Unterlegscheibe oben in das Lenkrad ein, gefolgt von einer Federunterlegscheibe. Sichern Sie alles mit einer M8-Mutter.

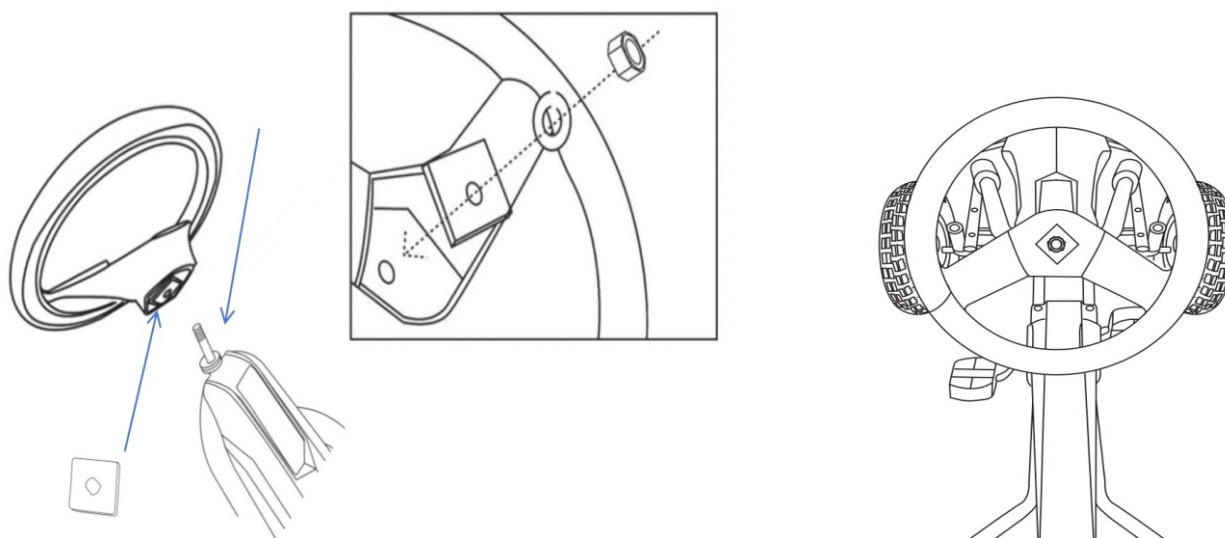

5. Montieren Sie die Pflanzenplatte:  
Befestigen Sie mit 2 Stück M5x35mm Schrauben und verwenden Sie, wo erforderlich, 2 Stück M5x12mm Unterlegscheiben und 2 Stück M5 Muttern.

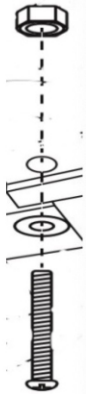
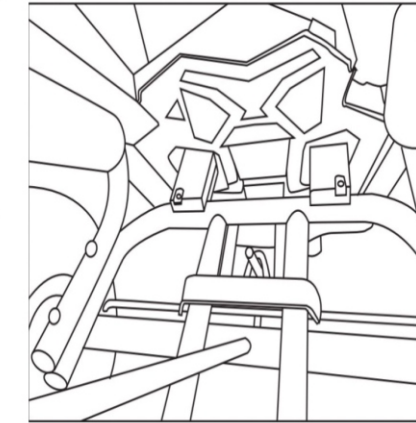
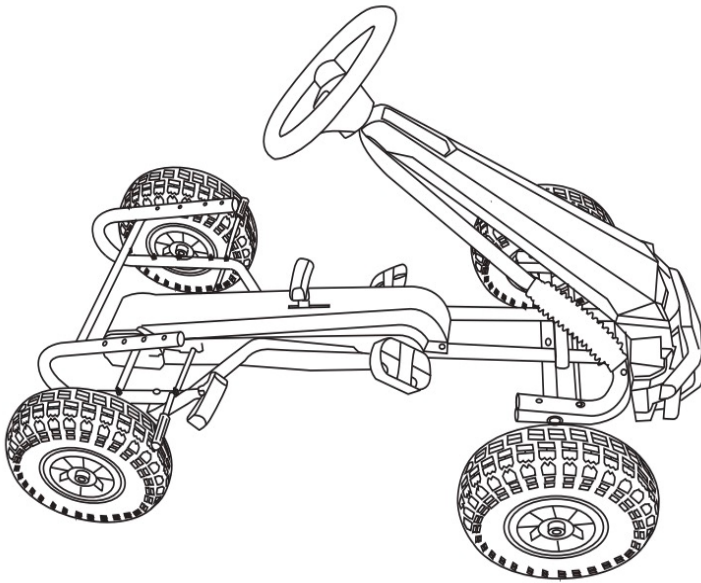

6. Platzieren Sie die Lenkradabdeckung in der Mitte des Lenkrads.



7. Befestigen Sie den Sitz am Go-Kart-Chassis mit 4 Stück M5x40mm-Schrauben und verwenden Sie dabei jeweils 4 Stück M5x14mm-Scheiben und 4 Stück M5-Muttern, wo erforderlich.

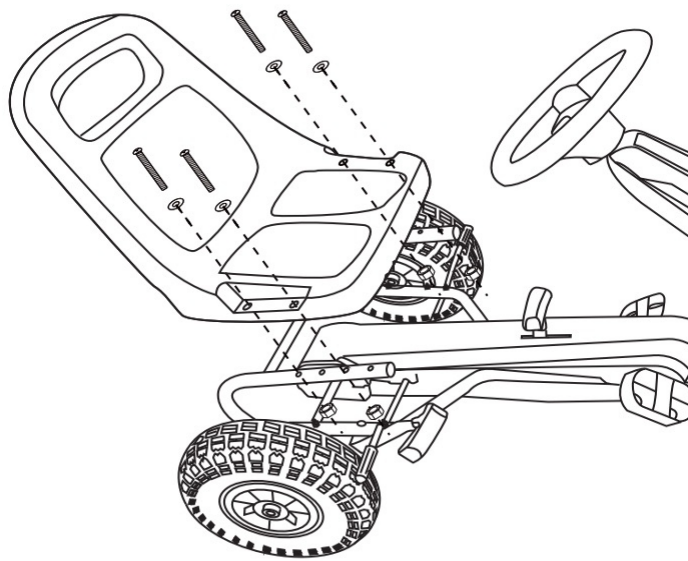

8. Stellen Sie sicher, dass alle Muttern und Schrauben vor der Verwendung fest angezogen sind und die Reifen richtig aufgepumpt sind.

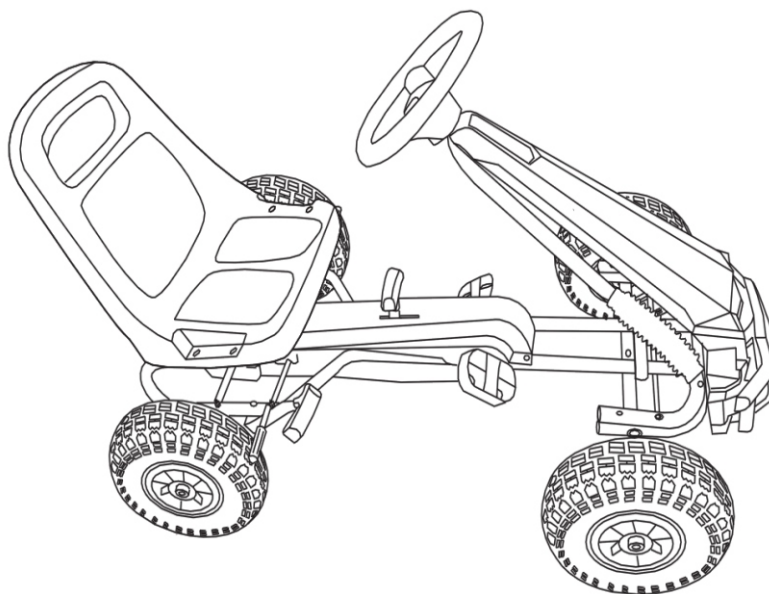

## **ACHTUNG:**

1. ERSTICKUNGSGEFAHR — Kleine Teile. Nicht für Kinder unter 3 Jahren geeignet.
2. Die Montage darf nur von Erwachsenen vorgenommen werden, halten Sie Kinder fern.
3. Kinder sollten damit auf einer flachen und glatten Oberfläche fahren und sich von Verkehrsstraßen fernhalten; In der Nähe von Kraftfahrzeugen, Straßen, Treppen, Hügeln, Straßen, Gassen, Schwimmbädern oder anderen Orten mit Wasser ist es strengstens verboten.
4. Dieses Produkt sollte unter Aufsicht von Erwachsenen verwendet werden und Schuhe getragen werden.
5. Dieses Produkt ist nur für eine Person.
6. Der Zusammenbau und die Installation aller Teile erfordern die Aufsicht eines Erwachsenen.
7. Lassen Sie Kinder nicht alleine mit diesem Produkt spielen, um Stürze zu verhindern.
8. Das Spielzeug sollte vorsichtig verwendet werden, da Geschicklichkeit erforderlich ist, um Stürze oder Kollisionen zu vermeiden, die dem Benutzer oder Dritten Verletzungen zufügen könnten.
9. Stellen Sie vor der Verwendung sicher, dass das Produkt richtig zusammengebaut ist.

### **WARTUNG & PFLEGE**

- A. Bewahren Sie alle Anweisungen und Teile, die sich auf dieses Produkt beziehen, zur späteren Verwendung auf.
- B. Prüfen Sie es regelmäßig auf Beschädigungen und ob alle Schrauben fest angezogen sind.
- C. Prüfen Sie, ob der Sitz sicher befestigt ist.
- D. Sauberkeit: Nur die Oberfläche mit einem trockenen Tuch abwischen.
- E. Lagerung: Halten Sie es von Feuer, Feuchtigkeit und anderen Bereichen mit hohen Temperaturen fern. Direkte Sonneneinstrahlung vermeiden.

## **Material der Produkte:**

A、(PP) B、(IRON)

# Lista de piezas (incluidas)

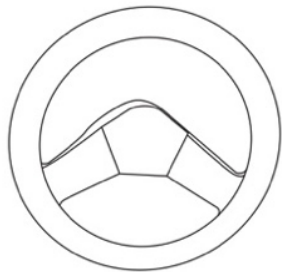

1. Volante \*1



2. Asiento \*1



3. Eje de dirección \*1  
(incluye  
3 arandelas de goma,  
arandela 1xM8x16mm washer,  
arandela cuadrada de acero x2,  
arandela de resorte x1 ,  
tuerca 1xM8)

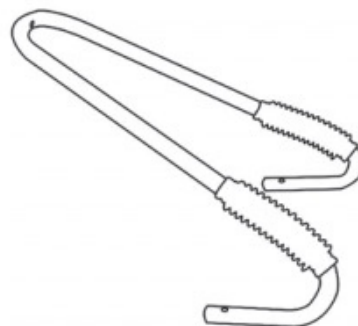

4. Soporte de dirección \*1



5. Manual

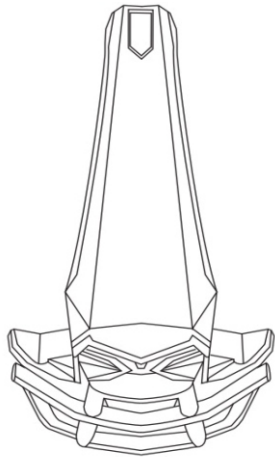

6. Panel frontal \*1

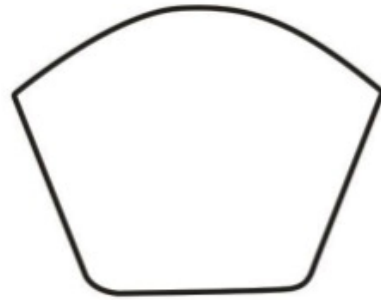

7. Cubierta del volante \*1

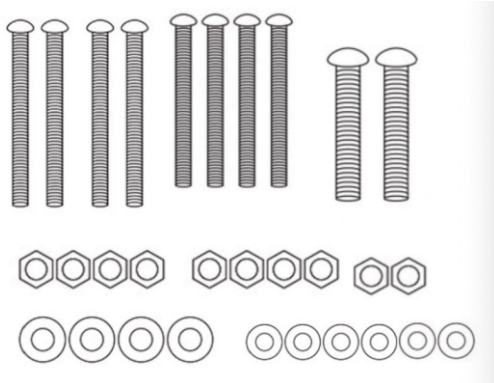

8. Bolsa de tuercas y tornillos:  
2 x Tornillos M5 de 35 mm,  
4 x Tornillos M5 de 40 mm,  
4 x Tornillos M5\* de 45 mm,  
6 x Arandelas M5\*12,  
4 x Arandelas M5\*14,  
10 tuercas M5

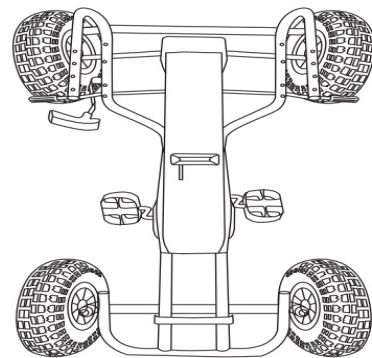

9. Carrocería de go kart

# Instrucciones de montaje:

1. Monte el soporte de dirección al chasis del kart. Fije con tornillos M5x45mm \*4pcs y asegúrese de usar arandelas de diámetro M5x12mm\*4pcs y tuercas M5 \*4pcs donde corresponda.

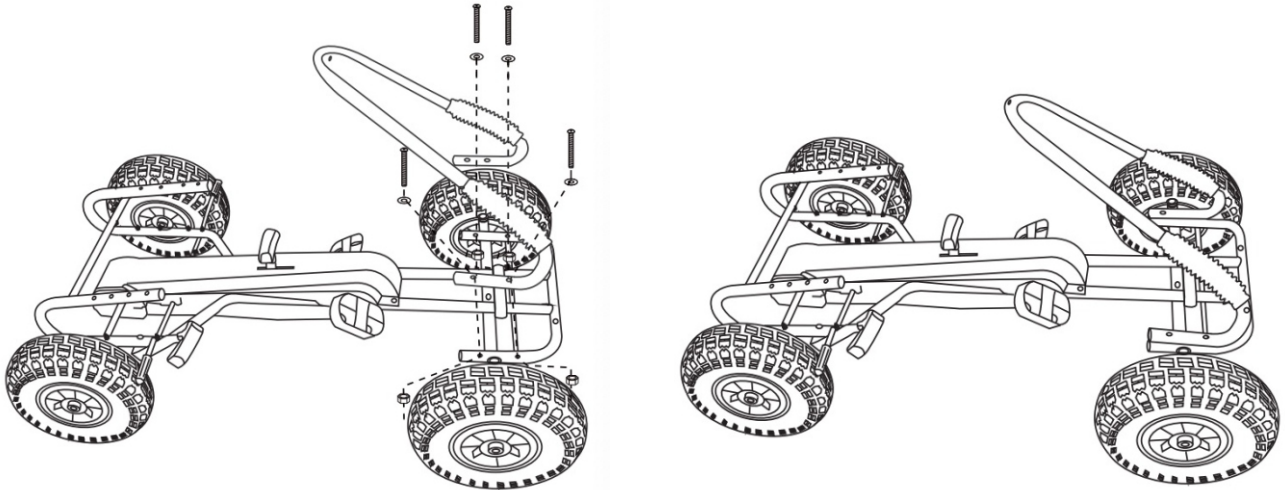

2. Ensamble el eje de dirección:

Retire la tuerca y las arandelas del eje de dirección. Inserte una arandela metálica en el eje de dirección.

Inserte el eje de dirección con la parte metálica desde abajo hacia el chasis del kart. El gancho del eje de dirección debe encajar en el área triangular de la barra de dirección. El eje de dirección debe pasar a través del chasis del kart y luego por el tubo de soporte de dirección.

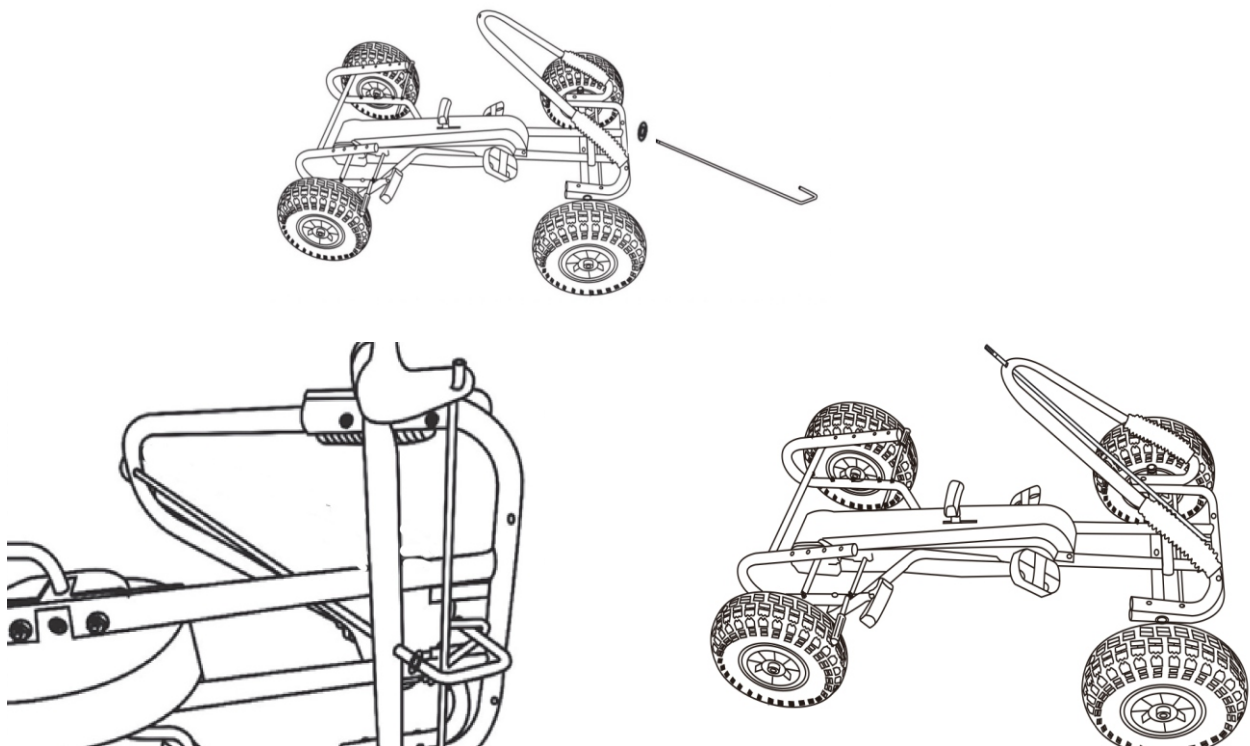

3. Coloca el panel de la planta en la parte delantera del kart.

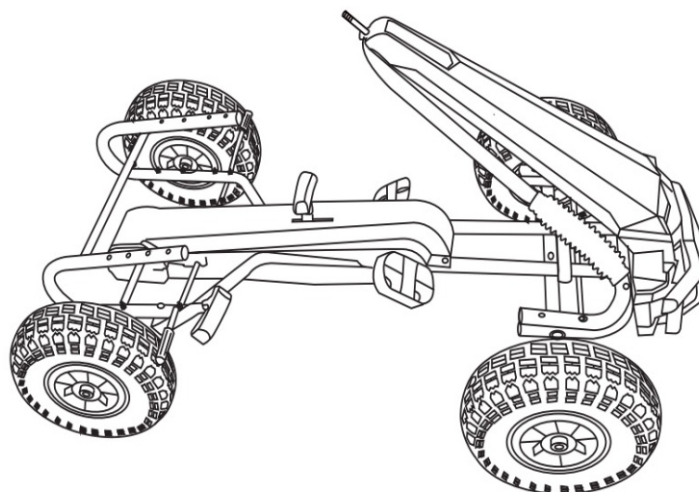

4. En el eje de dirección, inserta 2 arandelas de goma (la arandela de goma se usa para ajustar la longitud, utiliza 1-3 piezas para que ajustes). Añade una arandela cuadrada en la parte inferior del volante, luego inserta el volante. Coloca otra arandela cuadrada en la parte superior del volante, seguida de una arandela de resorte. Asegura todo en su lugar con una tuerca M8.

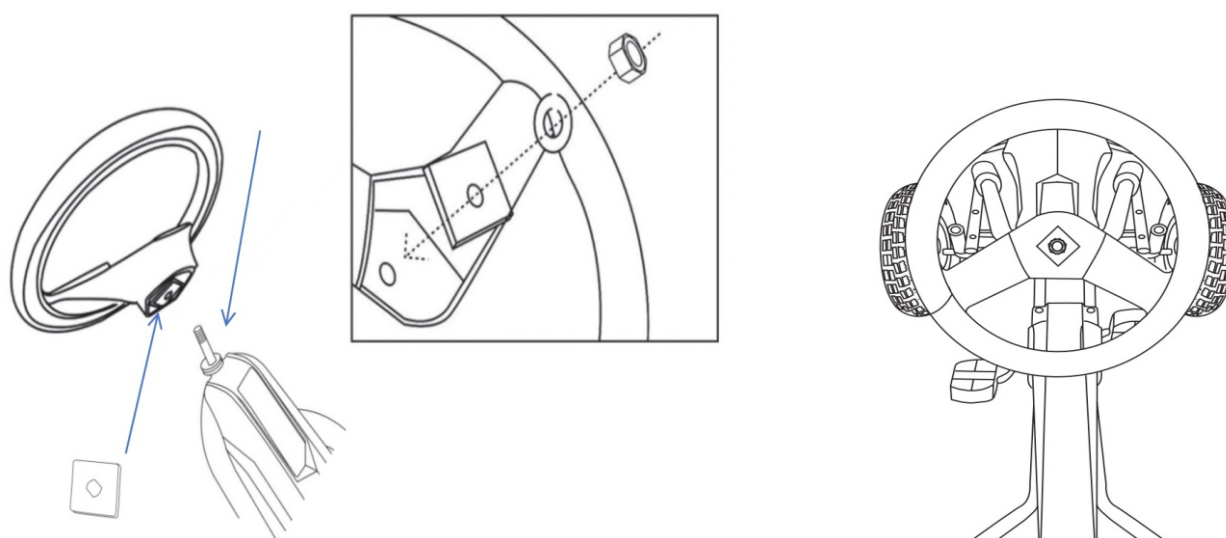

5. Ensamblar el panel de la planta:  
Fije con tornillos M5x35mm \*2pcs y asegúrese de usar arandelas de diámetro M5x12mm\*2pcs y tuercas M5 \*2pcs donde corresponda.

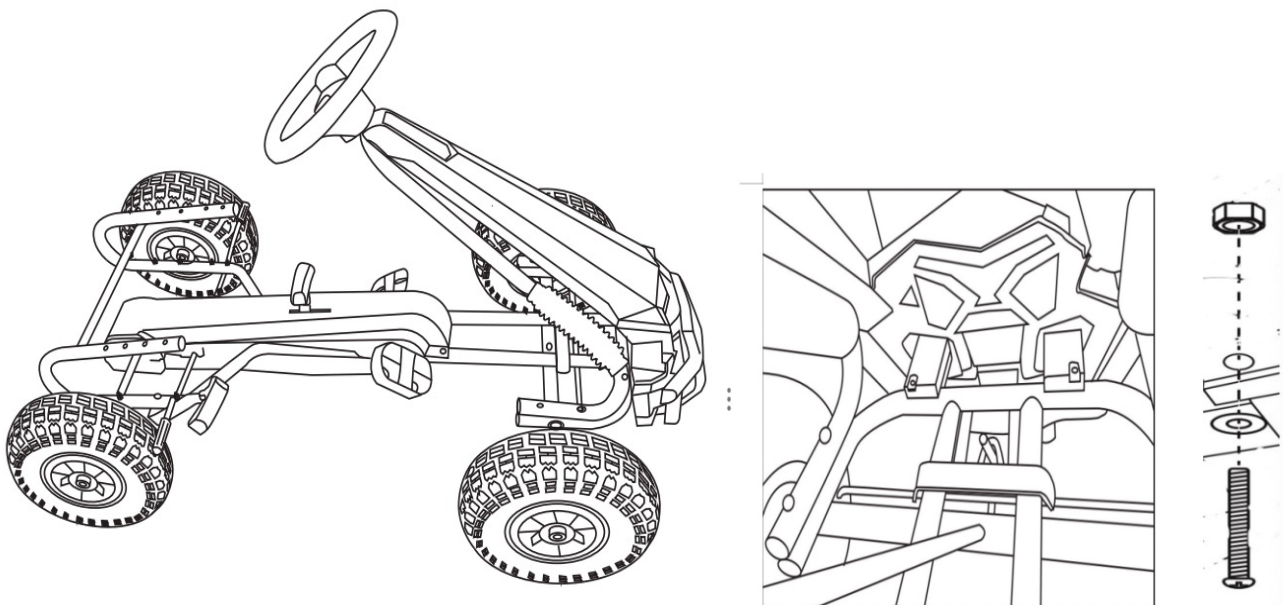

6. Colocar la cubierta del volante en el centro del volante.



7. Fije el asiento al chasis del kart utilizando tornillos M5x40mm\*4pcs, asegúrese de usar arandelas de diámetro M5x14mm\*4pcs y tuercas M5\*4pcs nuevamente donde corresponda.

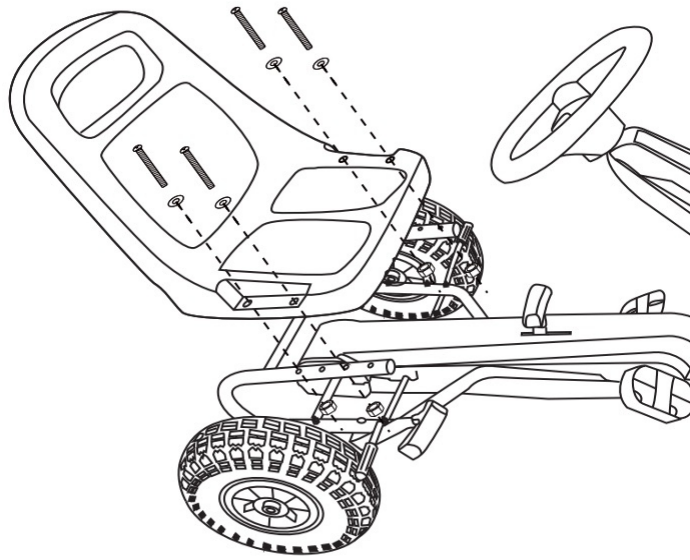

8. Asegúrese de que todas las tuercas y tornillos estén bien apretados antes de usar, y que los neumáticos estén inflados correctamente.

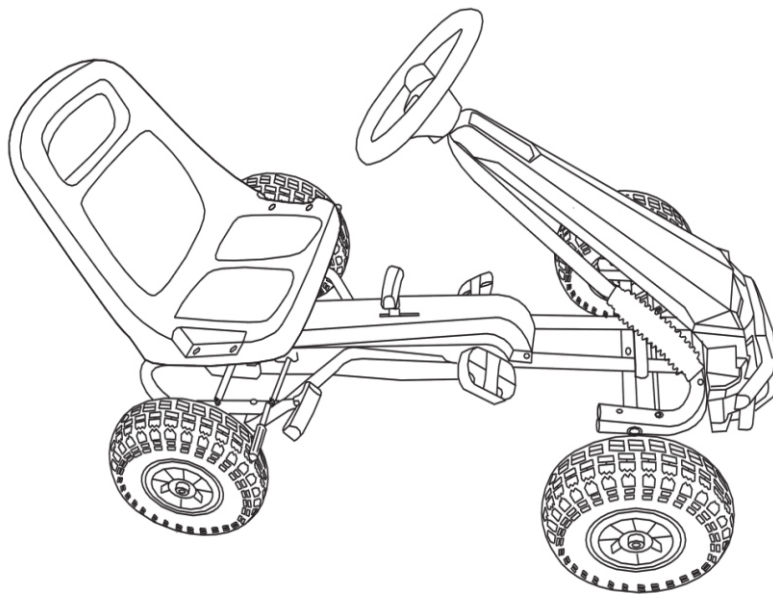

## **ADVERTENCIAS:**

1. PELIGRO DE ATRAGANTAMIENTO—Partes pequeñas. No apto para menores de 3 años.
2. La instalación sólo se puede realizar por los adultos, mantenga a los niños alejados al instalar el scooter.
3. Los niños deben montar esto en una superficie plana y lisa y mantenerse alejados de la carretera; Está estrictamente prohibido cerca de vehículos motorizados, calles, escalones, pendientes, colinas, carreteras, callejones, piscinas u otros lugares con agua;
4. Este producto debe ser utilizado bajo la supervisión de adultos y se deben usar zapatos.
5. Este producto está limitado a un solo pasajero.
6. Se requiere el montaje y la instalación de todas las partes por parte de un adulto.
7. No permita que los niños jueguen solos con este producto para evitar peligros de caída.
8. El juguete debe usarse con precaución, ya que se requiere habilidad para evitar caídas o colisiones que puedan causar lesiones al usuario o a terceros.
9. Asegúrese de que este automóvil esté montado de manera correcta antes de utilizarlo.

### **MANTENIMIENTO Y CUIDADO**

- A. Guarde todas las instrucciones y piezas relativas juntas con este producto para las referencias futuras.
- B. Compruebe regularmente para asegurarse de que no haya daños y que todos los tornillos estén apretados firmemente.
- C. Compruebe que el asiento del scooter esté abrochado firmemente.
- D. Limpieza: Limpiar únicamente la superficie con un paño seco.
- E. Almacenamiento: Mantenga el triciclo alejado del fuego, la humedad y otras áreas de alta temperatura. Evitar la exposición directa al sol.

## **Material de los productos:**

A、(PP) B、(IRON)

# Elenco dei componenti (inclusi):

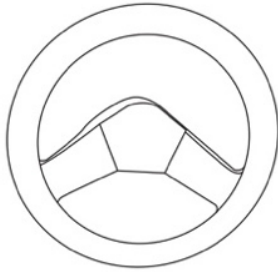

1. Volante \*1



2. Posto \*1



3. Albero dello sterzo \*1  
(inclusi  
3x rondella di gomma,  
1xM8x16mm rondella,  
2x rondella quadrata in acciaio,  
1x rondella elastica,  
1xM8 dado)

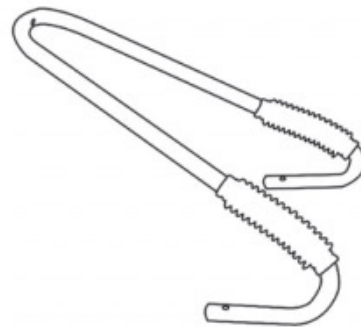

4. Supporto per il volante \*1



5. Manuale

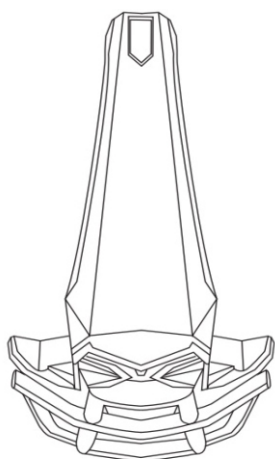

6. Pannello frontale \*1

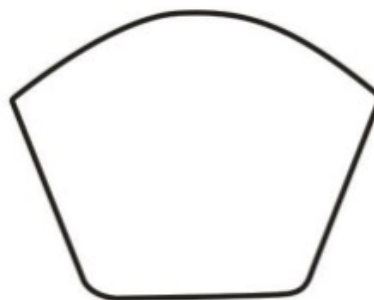

7. Coprivolante\*1

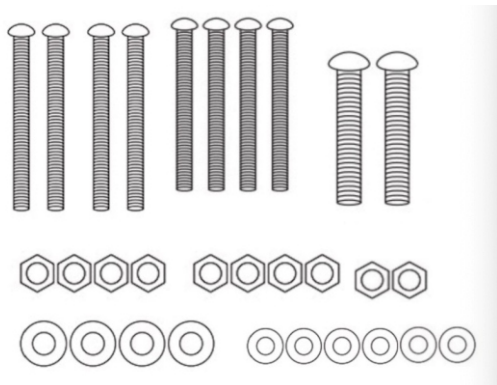

8. Sacchetto di dadi e bulloni:  
2 x bulloni M5 da 35 mm,  
4 x bulloni M5 da 40 mm,  
4 x Bulloni M5\* 45 mm,  
6 x Rondelle M5\*12,  
4 x Rondelle M5\*14,  
10x Dadi M5

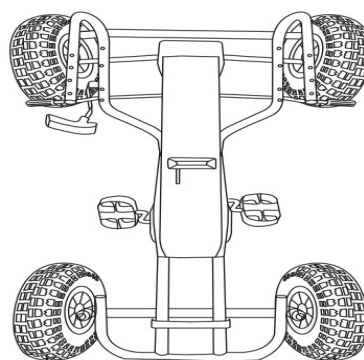

9. Carrozzeria del go-kart

# Istruzioni di montaggio:

1. Montare il supporto dello sterzo sul telaio del go kart. Fissare con viti M5x45mm \*4pcs e assicurarsi di utilizzare rondelle diametro M5x12mm\*4pcs e dadi M5 \*4pcs dove appropriato.

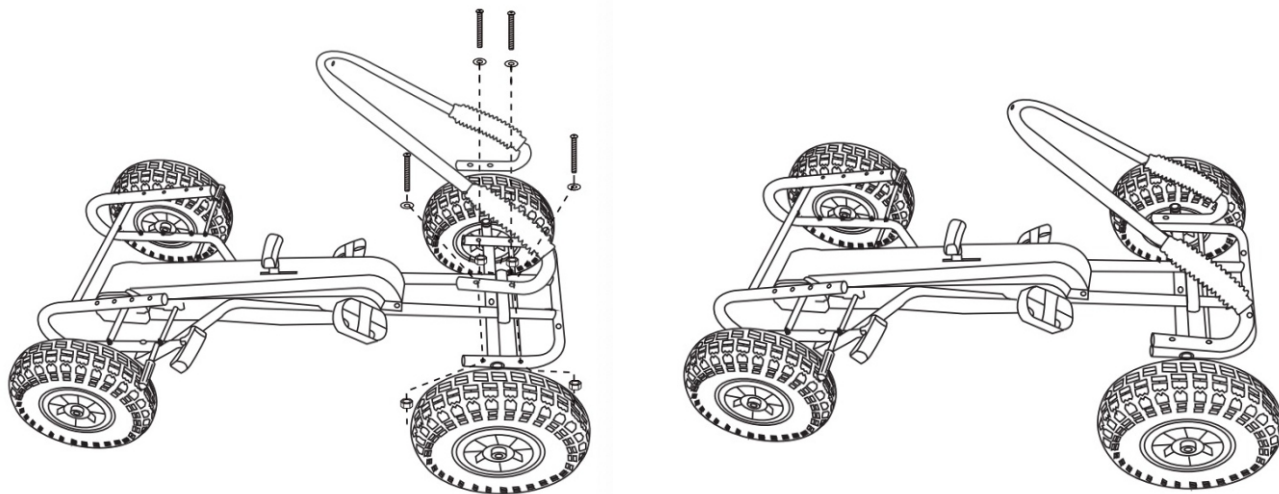

2. Montare l'albero dello sterzo:

Rimuovere il dado e le rondelle dall'albero dello sterzo. Inserire una rondella metallica nell'albero dello sterzo.

Inserire l'albero dello sterzo con la parte metallica dal basso nel telaio del go kart. Il gancio dell'albero dello sterzo deve entrare nell'area triangolare del collegamento dello sterzo. L'albero dello sterzo passa attraverso il telaio del go kart e poi attraverso il tubo di supporto dello sterzo.

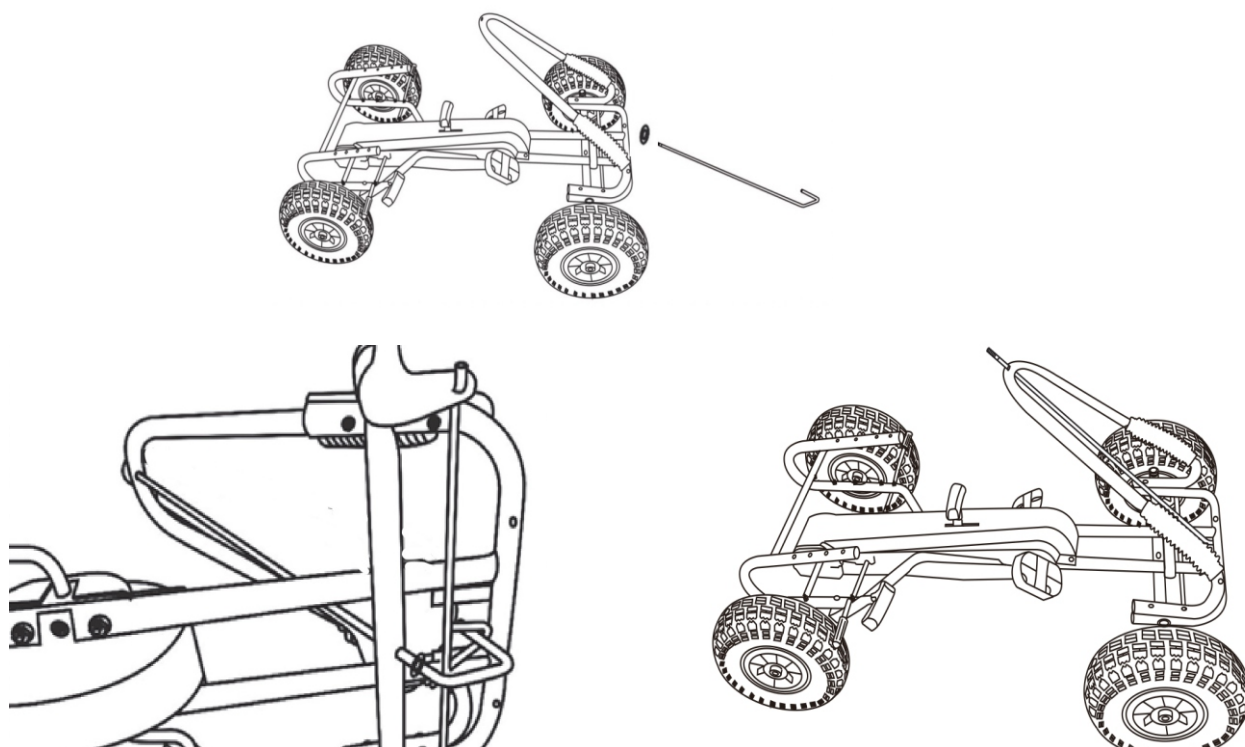

3. Posiziona il pannello della pianta sulla parte anteriore del go-kart.

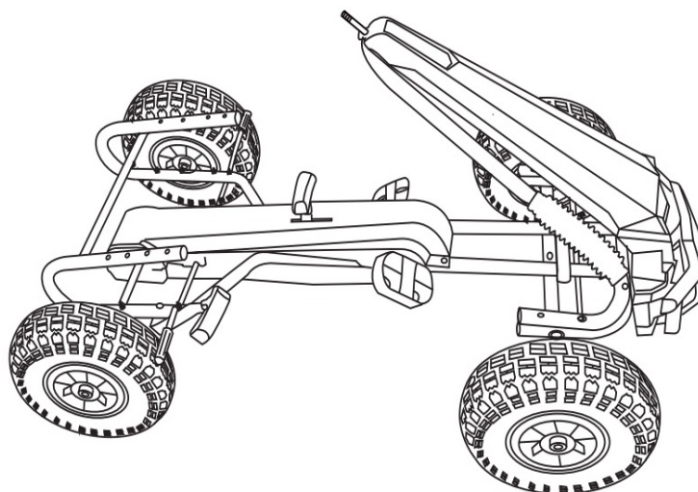

4. Sull'albero dello sterzo, inserire 2 rondelle di gomma (la rondella di gomma viene utilizzata per regolare la lunghezza, utilizzare 1-3 pezzi per la regolazione). Aggiungere una rondella quadrata alla base del volante, quindi inserire il volante. Inserire un'altra rondella quadrata all'interno della parte superiore del volante, seguita da una rondella elastica. Fissare il tutto con un dado M8.

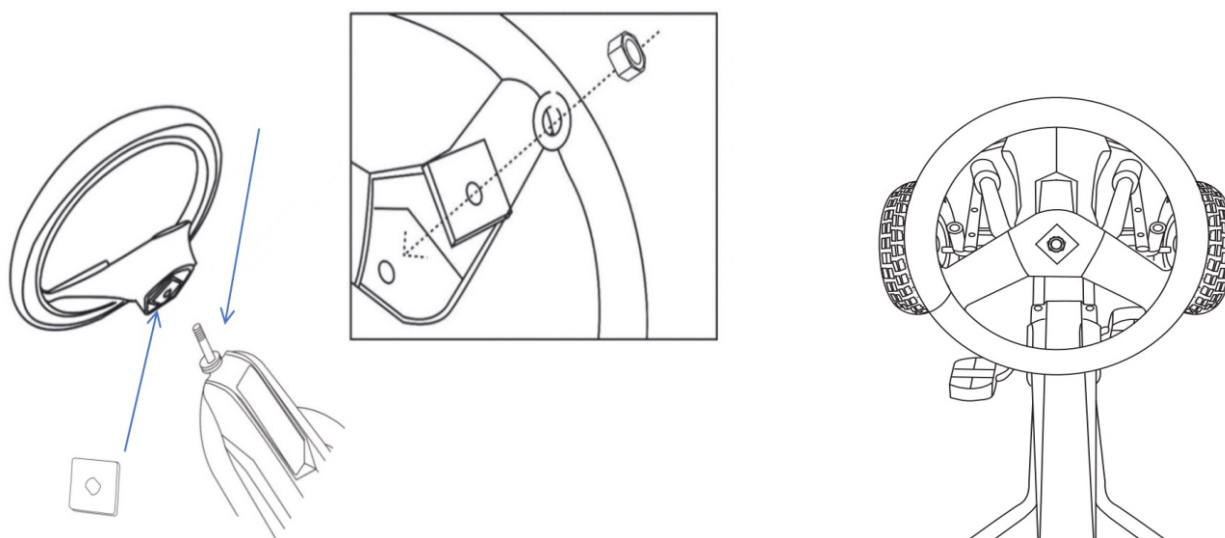

5. Montare il pannello dell'impianto:  
Fissare con viti M5x35mm \*2pcs e assicurarsi di utilizzare rondelle diametro M5x12mm\*2pcs e dadi M5 \*2pcs dove appropriato.

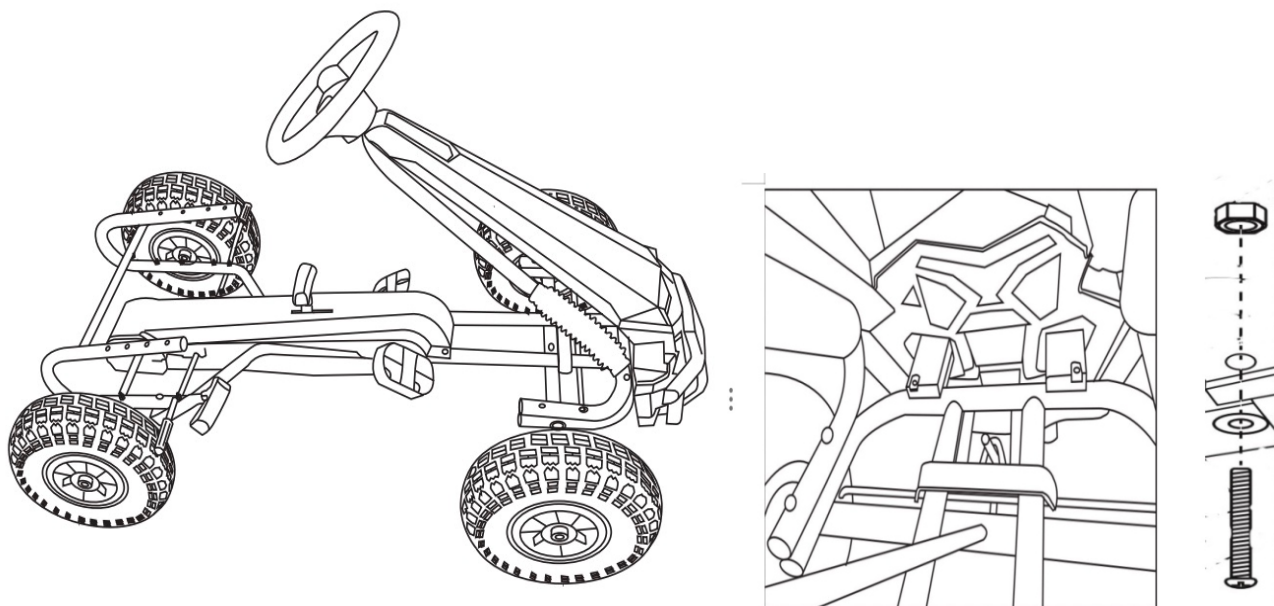

6. Posizionare la copertura del volante al centro del volante.



7. Fissare il sedile al telaio del go kart utilizzando viti M5x40mm\*4pcs, assicurarsi di utilizzare rondelle diametro M5x14mm\*4pcs e dadi M5\*4pcs ancora dove appropriato.

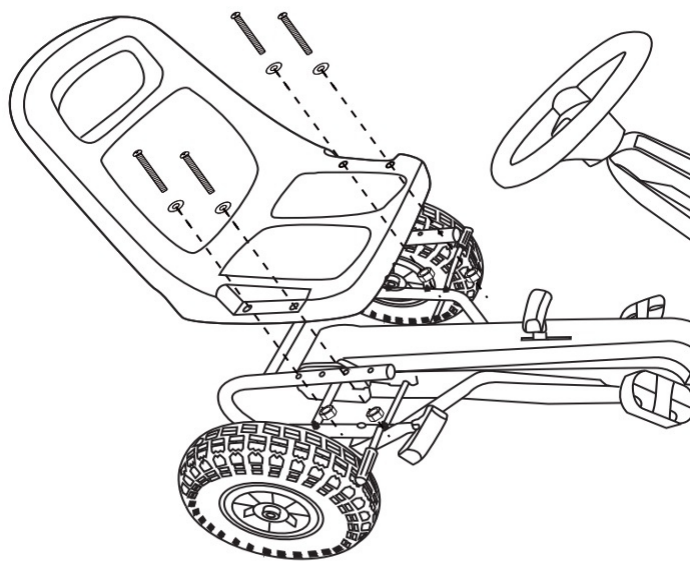

8. Assicurarsi che tutti i dadi e i bulloni siano ben serrati prima dell'uso e che i pneumatici siano gonfiati correttamente.

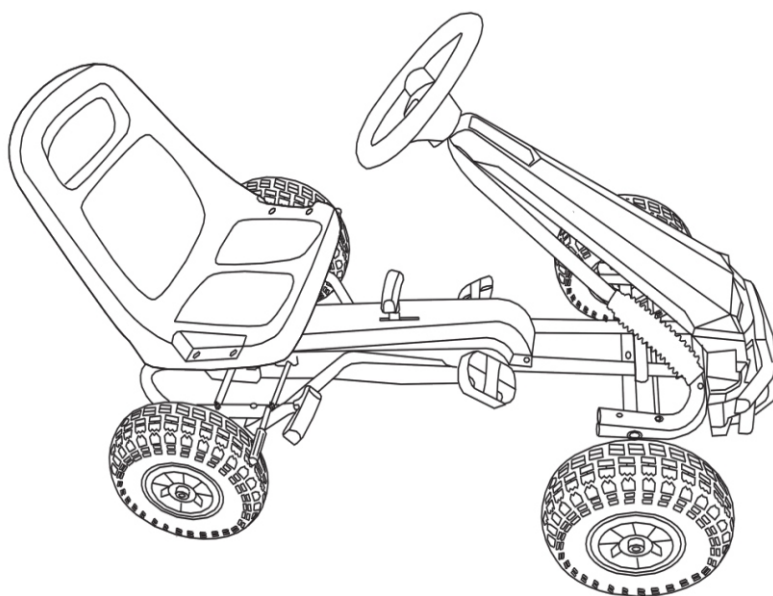

## **AVVERTENZE:**

1. RISCHIO DI SOFFOCAMENTO— Piccole parti. Non adatto a bambini di età inferiore a 3 anni.
2. Consentire l'installazione solo agli adulti, tenere lontani i bambini.
3. I bambini devono utilizzare questo prodotto su superfici piatte e lisce e tenersi alla larga dalle strade trafficate. È severamente vietato l'uso in prossimità di veicoli a motore, strade, gradini, pendii, colline, vicoli, piscine o altri luoghi con acqua.
4. Questo prodotto deve essere utilizzato sotto la supervisione di un adulto e il bambino deve indossare le scarpe.
5. Questo prodotto è destinato all'uso individuale.
6. È richiesto che un adulto assembli e installi tutti i componenti.
7. Non lasciare che i bambini giochino con questo prodotto da soli, per evitare il rischio di caduta.
8. Il giocattolo deve essere utilizzato con cautela, poiché è richiesta una certa destrezza per evitare cadute o collisioni che potrebbero causare lesioni all'utente o a terzi.
9. Assicurarsi che questo prodotto sia assemblato correttamente prima dell'uso.

### **MANUTENZIONE & CURA**

- A. Conservare tutte le istruzioni e le parti relative a questo prodotto per riferimenti futuri.
- B. Verificare regolarmente la presenza di danni e che tutte le viti siano strette saldamente.
- C. Verificare che il sedile sia fissato in sicurezza.
- D. Pulizia: Pulire solo la superficie con un panno asciutto.
- E. Conservazione: tenere lontano da fuoco, umidità e aree ad alta temperatura. Evitare l'esposizione diretta al sole.

## **Materiale dei prodotti:**

A、(PP) B、(IRON)

**UK**

If you have any questions, please contact our customer care centre.

Our contact details are below:



0044-800-240-4004



enquiries@mhstar.co.uk

IMPORTER ADDRESS:

MH STAR UK Ltd  
1 Northampton Cross Logistics Park  
Northampton Cross Road  
Northampton  
NN4 9FH  
MADE IN CHINA

**ES**

Si tiene alguna pregunta, comuníquese con nuestro Centro de Atención al Cliente. Nuestros datos de contacto son los siguientes:



0034-931294512



atencioncliente@aosom.es

Importador/Fabricante/REP:

Spanish Aosom, S.L.  
C/ Roc Gros, nº 15. 08550, Els Hostalets de Balenyà, Spain.  
B66295775  
atencioncliente@aosom.es  
TEL: 931294512  
HECHO EN CHINA

**FR**

Si vous avez la moindre question, veuillez contacter notre centre d'assistance à la clientèle.

Nos coordonnées sont les suivantes:



0033-1-84166106



aosom@mhfrance.fr

Importé par/Fabricant/REP:

MH France  
2, rue Maurice Hartmann  
92130 Issy-les-Moulineaux  
France  
FABRIQUÉ EN CHINE



Adresses sur [quefairedemesdechets.fr](http://quefairedemesdechets.fr)

**DE**

Wenn Sie Fragen haben, wenden Sie sich bitte an unser Kundendienstzentrum.

Unsere Kontaktdaten stehen unten:



0049-0(40)-87408465



service@aosom.de

Importeur/Hersteller/REP:

MH Handel GmbH  
Wendenstraße 309  
D-20537 Hamburg  
Germany  
IN CHINA HERGESTELLT

**IT**

In caso di dubbio, si prega di contattare il nostro centro assistenza clienti. I nostri dettagli di contatto sono di seguito:



0039-0249471447



clienti@aosom.it

IMPORTATO DA/Produttore/REP:

AOSOM Italy srl  
Centro Direzionale Milanofiori  
Strada 1 Palazzo F1  
20057 Assago (MI)  
P.I.: 08567220960  
FATTO IN CINA

