

EN Maximum user weight is 100 kg.

FR Le poids maximal de l'utilisateur est de 100 kg.

DE Das maximale Benutzergewicht beträgt 100 kg.

ES El peso máximo del usuario no puede exceder 100 kg.

IT Il peso massimo dell'utente è 100 KGS.

EN IMPORTANT, RETAIN FOR FUTURE REFERENCE: READ CAREFULLY.

FR IMPORTANT : A LIRE ATTENTIVEMEN ET A CONSERVER POUR VOUS Y REFERER ULTERIEUREMENT

ES IMPORTANTE, LEA Y GUARDE PARA FUTURAS REFERENCIAS.

DE WICHTIG! SORGFÄLTIG LESEN UND FÜR SPÄTER NACHSCHLAGEN AUFBEWAHREN.

IT IMPORTANTE! CONSERVARE IL PRESENTE MANUALE PER FUTURO RIFERIMENTO E LEGGERLO ATTENTAMENTE.

READING CAREFULLY!**Please keep this manual in a safe place for easy reference**

1. It is important to read this entire manual before assembling and using the equipment. Safe and effective use can only be achieved if the equipment is assembled, maintained and used properly. It is your responsibility to ensure the tall users of the equipment are informed of all warnings and precautions.
2. Before starting any exercise program you should consult your doctor to determine if you have any medical or physical conditions that could put your health and safety at risk, or prevent you from using the equipment properly. Your doctor's advice is essential if you are taking medication that affects your heart rate, blood pressure or cholesterol level.
3. Be aware of your body's signals. Incorrect or excessive exercise can damage your health. Stop exercising if you experience any of the following symptoms: pain, tightness in your chest, irregular heartbeat, extreme shortness of breath, lightheadedness, dizziness, or feelings of nausea. If you do experience any of these conditions, you should consult your doctor before continuing with your exercise program only.
4. Keep children and pets away from the equipment. The equipment is designed for adult use only.
5. Use the equipment on a solid, flat level surface with a protective cover on your floor or carpet. To ensure safety, the equipment should have at least 0.5 meters of free space all around it.
6. Before using the equipment, check that the nuts and bolts are securely tightened.
7. The safety of the equipment can only be maintained if it is regularly examined for damage and/or wear and tear.
8. Always use the equipment as indicated. If you find any defective components while assembling or checking the equipment, or if you hear any unusual noises coming from the equipment during use, stop immediately. Do not use the equipment until the problem has been rectified.
9. Wear suitable clothing while using the equipment. Avoid wearing loose clothing that may get caught in the equipment or that may restrict or prevent movement.
10. The equipment has passed relevant tests and certifications. Suitable for home use only. Braking ability is independent of speed.
11. The equipment is not suitable for therapeutic use.
12. Care must be taken when lifting or moving the equipment so as not to injure your back. Always use proper lifting techniques and/or seek assistance necessary.
13. **DO NOT** attempt to service the product yourself except for the maintenance tasks which are described in this manual. The product does not contain any user-serviceable parts so disassembling it yourself will not only void your warranty and could result in serious injury.

Attention!

- 1.If the computer would not be displaying data normally, please install the battery again.
- 2.The battery must be taken out from the computer for safe treatment once it was out of energy for trash.
- 3.This manual is also suitable for equipment without computer.

MAINTAIN

Neutral detergent can be used to dilute the water to wipe the cloth carefully wipe the oil, and then dry with a dry cloth.

Do not use alkaline solvents, solvents such as solvent, volatile oils and other solvents.

MAINTENANCE / INSPECTION

Avoid high temperature, moisture or direct sunlight, please place in a well-ventilated place.

When not in use please fold the admission, and placed in the children can not touch the Department.

If you do not use it for a while, be sure to check the precautions before using this product and use it for normal use.

When you accidentally wet the product, use a dry cloth to avoid skidding.

In case of malfunction, abnormality or any operational problem, please contact us at the company.

PRODUCT RECYCLING

Due to the different national recycling regulations, please refer to the relevant regulations.

BATTERY WARNING:

1. Do not mix alkaline, standard (carbon-zinc), or rechargeable (nickel-cadmium) batteries.
2. Never mix old and new batteries.
3. Batteries are to be inserted with the correct polarity.
4. Remove the batteries when the unit is not in use for long periods.
5. The supply terminals are not to be short-circuited.
6. Always comply with local laws and regulations.

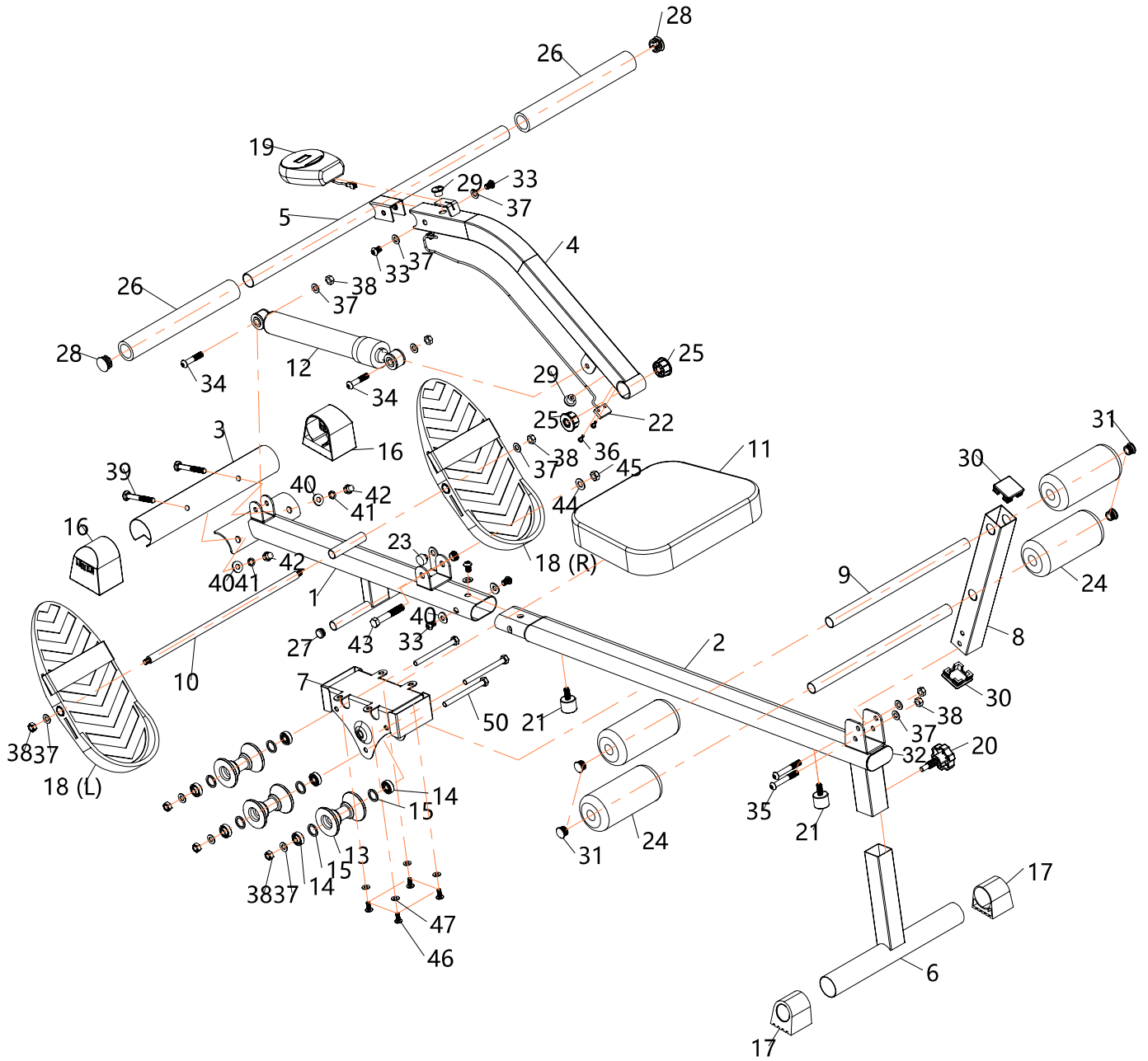

NO.	NAME	QTY
1	Front main frame	1
2	Rear main frame	1
3	Front stabilizer	1
4	The handle support	1
5	Handle bar	1
6	Rear stabilizer	1
7	Seat post	1
8	Back tube	1
9	Foam tube	2
10	Axle for pedal	1
11	Seat	1
12	Cylinder	1
13	Roller	3
14	Bearing	6
15	Washer	6
16	D-type end cap $\phi 50$	2
17	D-type end cap $\phi 38$	2
18	Pedal (L, R)	1
19	Computer	1
20	Knob M12x40	1
21	Buffer pad 8x20	2
22	Sensor	1
23	Magnet	1
24	Foam $\phi 60^* \phi 17^* 140$	4
25	Bushing	2

NO.	NAME	QTY
26	Foam $\phi 23 \times 5.0T \times 250$	2
27	Round plug $\phi 16$	2
28	Round plug $\phi 25$	2
29	Wire plug $\phi 12$	2
30	Square plug 38x38	2
31	Round plug $\Phi 19$	4
32	Elliptical plug 30x60	1
33	Half round head hexagon bolt M8X12	5
34	Half round head hexagon bolt M8X40	2
35	Half round head hexagon bolt M8X55	2
36	Round head cross tapping screw M4.2x13	2
37	Flat washer $\phi 8^* \phi 16^* 1.5T$	12
38	Nut M8	9
39	Carriage screw M8x65	2
40	Curved washer $\phi 8^* \phi 19^* 1.5T$	4
41	Elastic washer M8x2.0T	2
42	Cover nut M8	2
43	Hexagon Head Screw M10x60	1
44	Flat washer $\phi 10 \times \phi 20 \times 1.5T$	1
45	Nut M10	1
46	Cross shaped flat head screw M6x14	4
47	Flat washer $\phi 6.4 \times \phi 13 \times 1.2T$	4
50	Hexagon Head Screw M8x90	3

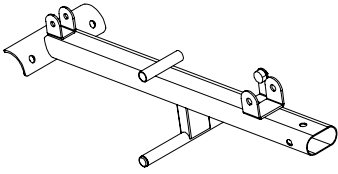

1#
1 PC

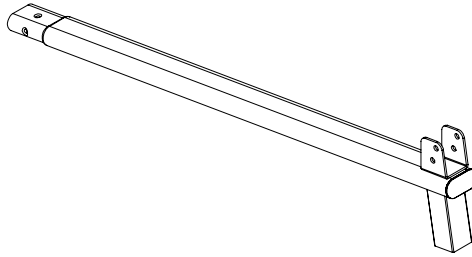

2#
1 PC

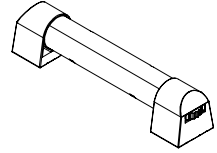

3#
1 PC

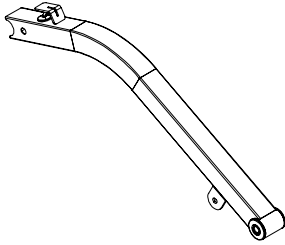

4#
1 PC

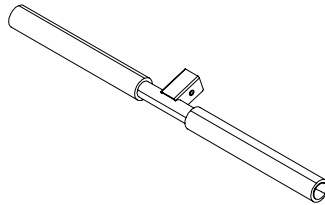

5#
1 PC

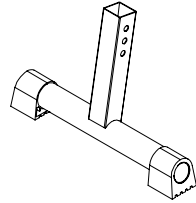

6#
1 PC

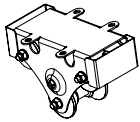

7#
1 PC

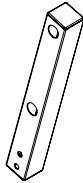

8#
1 PC

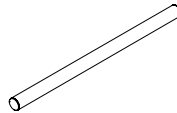

9#
2 PCS

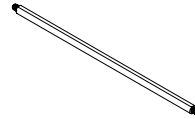

10#
1 PC

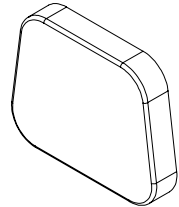

11#
1 PC

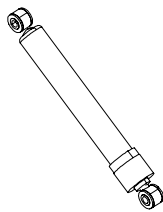

12#
1 PC

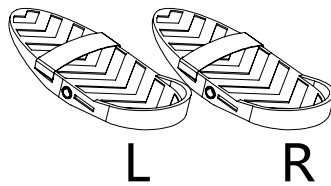





18#
1 PC

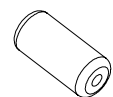

19#
1 PC





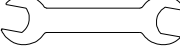

24#
4 PCS

NO.	HARDWARE & TOOLS	QTY
39		M8x65 2 PCS
40		8x19 2 PCS
41		M8 2 PCS
42		M8 2 PCS
49		13x14 1 PC

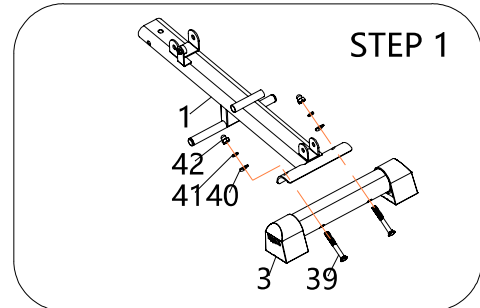
STEP 1:

1. Connect 3 and 1 with 39, 40, 41, and 42 as shown in the illustration, and tighten them with 49 # wrench.





NO.	HARDWARE & TOOLS	QTY
46		M6x14 4 PCS
47		6x13 4 PCS
21		8x25 2 PC
48		S5 1 PC

STEP 2:

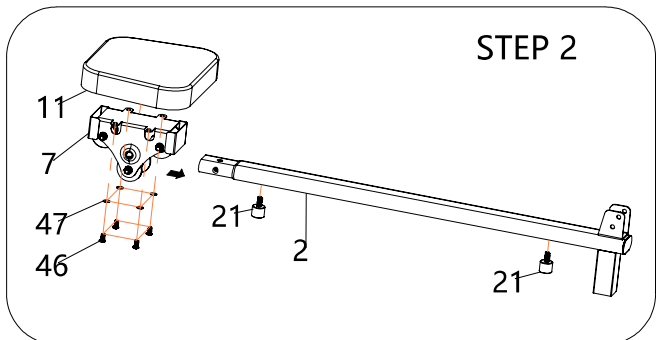
1. Connect 11 and 7 with 46 and 47, and lock them with 48 #;
2. Then insert parts 2 to 2 in the direction of the arrow;
3. Fix 21 with 32 onto 2.





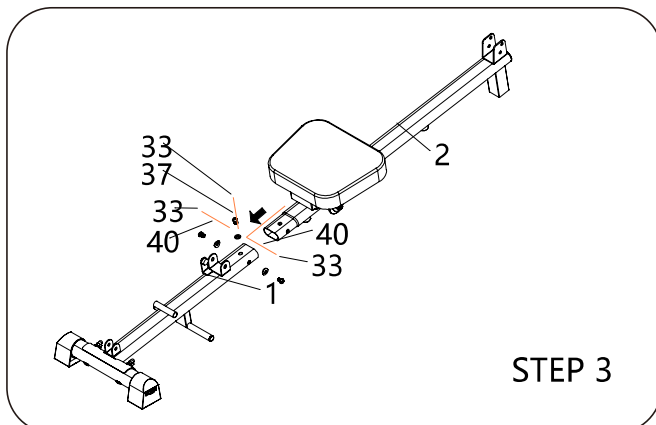

NO.	HARDWARE & TOOLS	QTY
33		M8x12 3 PCS
37		8x16 1 PC
40		8x19 2 PCS

STEP 3:

1. According to the illustration, insert 2 into 1, align with the hole, and connect with 33, 37, and 40. Connect and lock with 48.



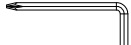
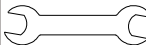



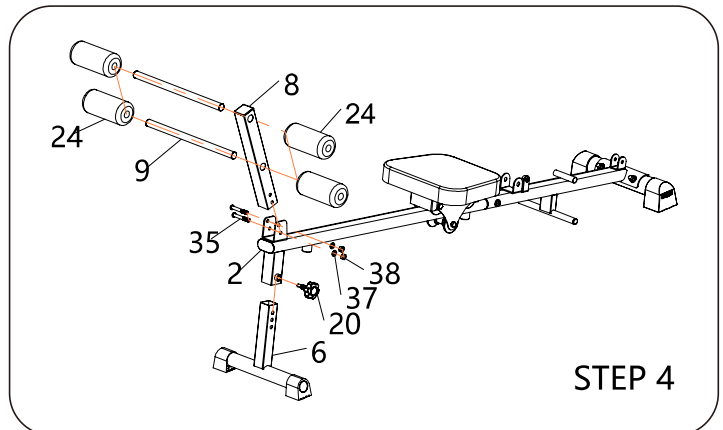

NO.	HARDWARE & TOOLS	QTY
20	 M12x40	1 PC
35	 M8x55	2 PCS
37	 8x16	2 PCS
38	 M8	2 PCS
48	 S5	1 PC
49	 13x14	2 PCS

STEP 4:

1. Insert 6 into 2, align with the hole, connect with 20, and lock with 20;
2. Connect 8 and 2 with 35, 37, and 38, and lock them with 48 # and 49 #;
3. Insert the left 24 into 9, then insert 8, and then insert the right 24.



NO.	HARDWARE & TOOLS	QTY
33	 M8x12	2 PCS
34	 M8x40	2 PCS
37	 8x16	4 PCS
38	 M8	2 PCS
43	 M10x60	1 PC
44	 10x20	1 PC
45	 M10	1 PC

STEP 5:

1. Connect 4 and 1 with 43, 44, and 45, and lock them with 49 #;
2. Connect 12 to 1 and 4 with 34, 37, and 38 respectively, and lock them with 48# and 49 #;
3. Insert 5 into 4 and lock it with 33 and 37, then tighten it with 48 #.

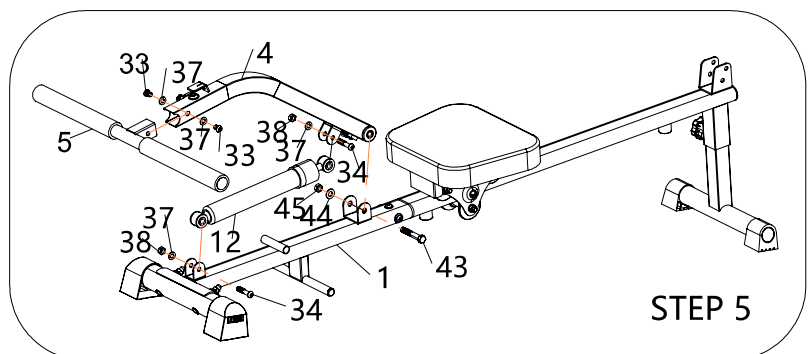

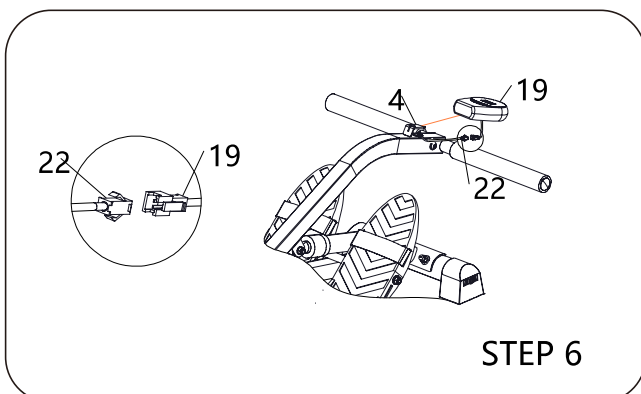

STEP 6:

1. Insert 19 into 4, fix it, and then connect 19 to the 33 wire plug.

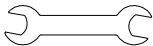

*** The instrument display includes 2x1.5V AA batteries.**

NO.	HARDWARE & TOOLS	QTY	
37		8x16	2 PCS
38		M8	2 PCS
49		13X14	2 PCS

STEP 7:

1. Connect 18 and 10 to 1 with 38 and 37, and lock them with 49 #.

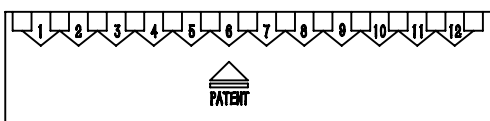
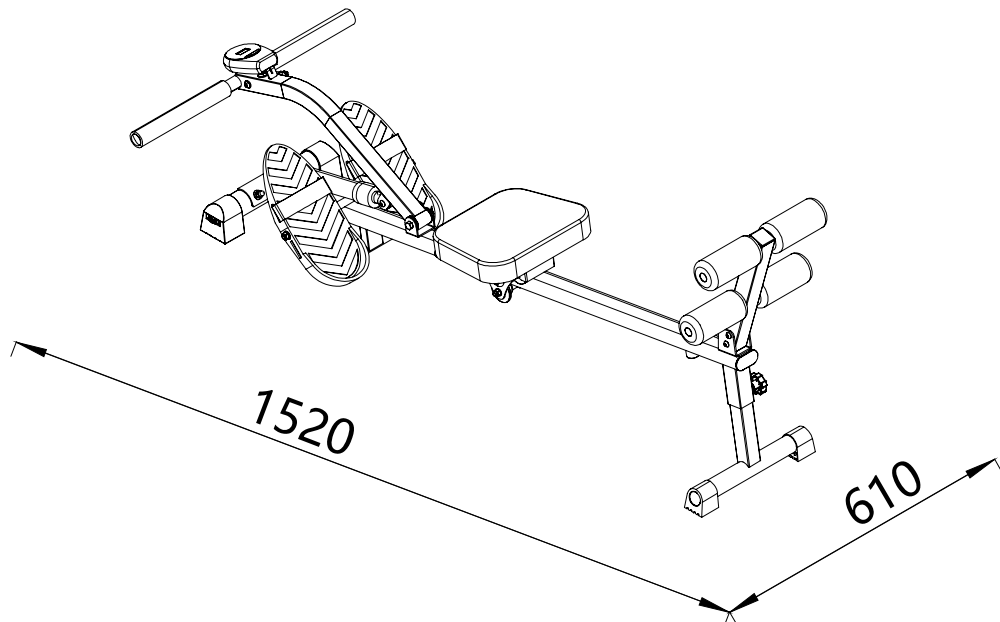
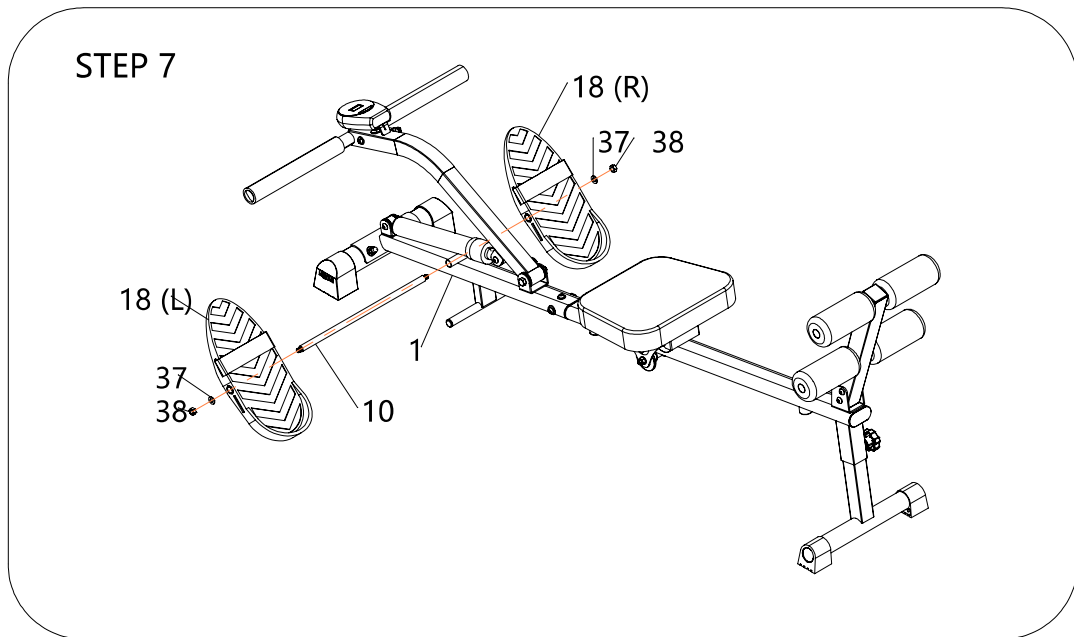

Description of hydraulic cylinder tension:

1. The hydraulic cylinder tension are divided into 1–12 levels, ranging from small to large
2. The tension is the smallest in the 1st and the largest in the 12th. When using, rotate the tension number to align with the arrow above the PATENT, and you will obtain the corresponding tension.

LIRE ATTENTIVEMENT !

Veillez conserver ce manuel dans un endroit sûr pour le consulter facilement.

1. Il est important de lire l'intégralité de ce manuel avant d'assembler et d'utiliser l'équipement. Une utilisation sûre et efficace ne peut être obtenue que si l'équipement est assemblé, entretenu et utilisé correctement. Il est de votre responsabilité de vous assurer que les utilisateurs de grande taille de l'équipement sont informés de tous les avertissements et précautions.
2. Avant de commencer tout programme d'exercice, vous devez consulter votre médecin pour déterminer si vous avez des problèmes médicaux ou physiques qui pourraient mettre en danger votre santé et votre sécurité, ou vous empêcher d'utiliser l'équipement correctement. L'avis de votre médecin est essentiel si vous prenez des médicaments qui affectent votre rythme cardiaque, votre tension artérielle ou votre taux de cholestérol.
3. Soyez conscients des signaux de votre corps. Un exercice incorrect ou excessif peut nuire à votre santé. Arrêtez de faire de l'exercice si vous ressentez l'un des symptômes suivants : douleur, oppression dans la poitrine, rythme cardiaque irrégulier, essoufflement extrême, étourdissement, vertige ou sensation de nausée. Si vous ressentez l'une de ces conditions, vous devriez consulter votre médecin avant de poursuivre votre programme d'exercices uniquement.
4. Tenez les enfants et les animaux domestiques éloignés de l'équipement. L'équipement est conçu pour être utilisé par des adultes uniquement.
5. Utilisez l'équipement sur une surface solide et plane avec une housse de protection sur votre sol ou votre tapis. Pour garantir la sécurité, l'équipement doit avoir au moins 0,5 mètre d'espace libre tout autour.
6. Avant d'utiliser l'équipement, vérifiez que les écrous et les boulons sont bien serrés.
7. La sécurité de l'équipement ne peut être maintenue que s'il est régulièrement examiné pour détecter tout dommage et/ou usure.
8. Si vous trouvez des composants défectueux lors du montage ou du contrôle de l'appareil, ou si vous entendez des bruits inhabituels provenant de l'appareil pendant son utilisation, arrêtez immédiatement. N'utilisez pas l'équipement tant que le problème n'a pas été résolu.
9. Portez des vêtements appropriés lorsque vous utilisez l'équipement. Évitez de porter des vêtements amples qui pourraient se coincer dans l'équipement ou qui pourraient restreindre ou empêcher les mouvements.
10. L'équipement a passé les tests et certifications appropriés. Convient uniquement à un usage domestique. La capacité de freinage est indépendante de la vitesse.
11. L'équipement n'est pas adapté à un usage thérapeutique.
12. Il faut faire attention en soulevant ou en déplaçant l'équipement afin de ne pas se blesser le dos. Utilisez toujours les techniques de levage appropriées et/ou demandez de l'assistance si nécessaire.
13. N'essayez PAS de réparer le tapis roulant vous-même, sauf pour les tâches d'entretien décrites dans ce manuel. Le tapis roulant ne contient aucune pièce réparable par l'utilisateur. Le démontage par vous-même annulera votre garantie et pourrait entraîner des blessures graves.

Attention !

1. Si l'ordinateur n'affiche pas les données normalement, veuillez installer la batterie à nouveau.
2. La batterie doit être retirée de l'ordinateur pour un traitement sûr une fois qu'elle n'a plus d'énergie pour être mise à la poubelle.
3. Ce manuel est également adapté aux équipements sans ordinateur.

ENTRETIEN

Un détergent neutre peut être utilisé pour diluer l'eau afin d'essuyer le chiffon avec précaution, puis sécher avec un chiffon sec.

N'utilisez pas de solvants alcalins, de solvants tels que les solvants, les huiles volatiles et autres solvants.

ENTRETIEN / INSPECTION

Évitez les températures élevées, l'humidité ou la lumière directe du soleil, veuillez le placer dans un endroit bien ventilé.

Lorsque vous ne l'utilisez pas, veuillez le plier et le placer dans un endroit où les enfants ne peuvent pas la toucher.

Si vous ne l'utilisez pas pendant un certain temps, veuillez à vérifier les précautions avant d'utiliser ce produit et utilisez-le pour une utilisation normale.

Lorsque vous mouillez accidentellement le produit, utilisez un chiffon sec pour éviter tout dérapage.

En cas de dysfonctionnement, d'anomalie ou de tout problème de fonctionnement, veuillez nous contacter auprès de l'entreprise.

RECYCLAGE DU PRODUIT

En raison des différentes réglementations nationales en matière de recyclage, veuillez vous référer aux réglementations en vigueur.

AVIS RELATIF AUX PILES :

1. Ne mélangez pas des piles alcalines, standard (carbone-zinc), ou rechargeables (nickel-cadmium).
2. Ne mélangez jamais des piles anciennes avec de nouvelles piles.
3. Les piles doivent être insérées avec la bonne polarité.
4. Retirez les piles lorsque l'appareil n'est pas utilisé pendant une longue période.
5. Les bornes d'alimentation ne doivent pas être court-circuitées.
6. Respectez toujours les lois et règlements locaux.



FR

Cet appareil,
ses accessoires,
cordons et batteries
se recyclent

REPRISE
À LA LIVRAISON



OU

À DÉPOSER
EN MAGASIN



OU

À DÉPOSER
EN DÉCHÈTERIE



Points de collecte sur www.quefairedemesdechets.fr
Privilégiez la réparation ou le don de votre appareil !

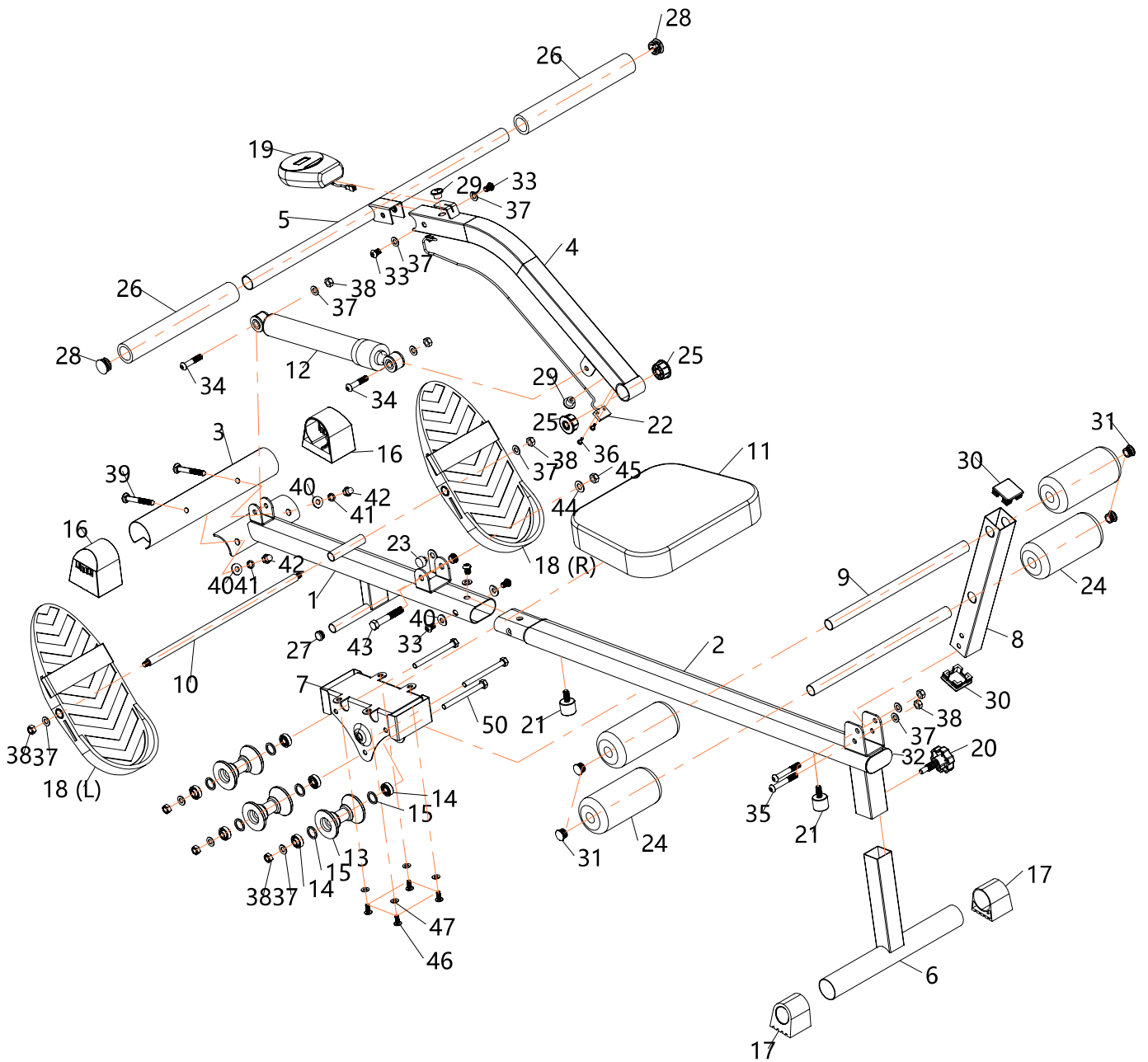

NO.	NAME	QTY
1	Cadre principal avant	1
2	Cadre principal arrière	1
3	Stabilisateur avant	1
4	Le support de poignée	1
5	Le guidon	1
6	Le stabilisateur arrière	1
7	Tige de selle	1
8	Le tube arrière	1
9	Tube en mousse	2
10	Axe pour pédale	1
11	Siège	1
12	Cylindre	1
13	Rouleau	3
14	Roulement	6
15	Rondelle	6
16	Capuchon d'extrémité de type D $\varnothing 50$	2
17	Capuchon d'extrémité de type D $\varnothing 38$	2
18	Pédale (G, D)	1
19	Ordinateur	1
20	Bouton M12x40	1
21	Tampon de mémoire 8x20	2
22	Capteur	1
23	Aimant	1
24	Mousse $\varnothing 60^* \varnothing 17^* 140$	4
25	Douille	2

NO.	NAME	QTY
26	Mousse $\varnothing 23 \times 5.0 \text{T} \times 250$	2
27	Bouchon rond $\varnothing 16$	2
28	Bouchon rond $\varnothing 25$	2
29	Fiche fil $\varnothing 12$	2
30	Fiche carrée 38x38	2
31	Fiche ronde $\Phi 19$	4
32	Fiche elliptique 30x60	1
33	Boulon hexagonal à tête demi-ronde M8X12	5
34	Boulon hexagonal à tête demi-ronde M8X40	2
35	Boulon hexagonal à tête demi-ronde M8X55	2
36	Vis à tête ronde cruciforme autoforeuse M4.2x13	2
37	Rondelle plate $\varnothing 8^* \varnothing 16^* 1.5\text{T}$	12
38	Écrou M8	9
39	Vis à tête carrée M8x65	2
40	Rondelle incurvée $\varnothing 8^* \varnothing 19^* 1.5\text{T}$	4
41	Rondelle élastique M8x2.0T	2
42	Écrou de couverture M8	2
43	Vis à tête hexagonale M10x60	1
44	Rondelle plate $\varnothing 10 \times \varnothing 20 \times 1.5\text{T}$	1
45	Écrou M10	1
46	Vis à tête plate cruciforme M6x14	4
47	Rondelle plate $\varnothing 6.4 \times \varnothing 13 \times 1.2\text{T}$	4
50	Vis à tête hexagonale M8x90	3

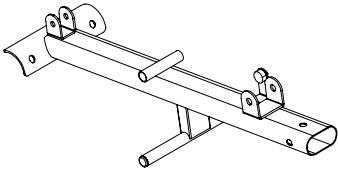

1#
1 PIÈCE

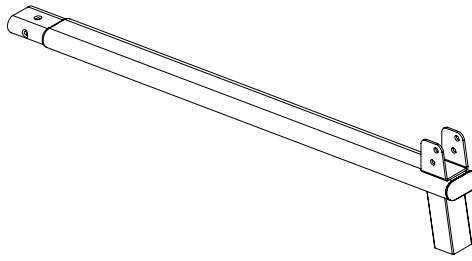

2#
1 PIÈCE

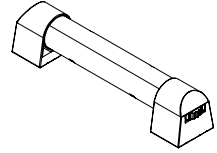

3#
1 PIÈCE

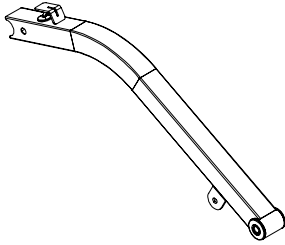

4#
1 PIÈCE

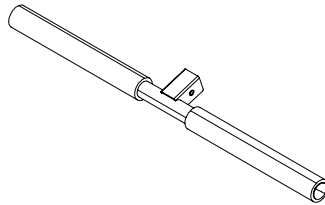

5#
1 PIÈCE

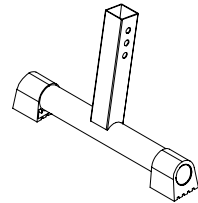

6#
1 PIÈCE

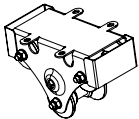

7#
1 PIÈCE

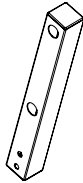

8#
1 PIÈCE

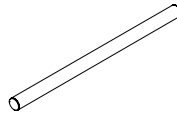

9#
2 PIÈCES

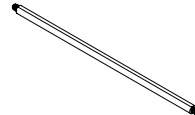

10#
1 PIÈCE

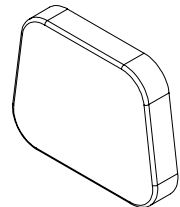

11#
1 PIÈCE

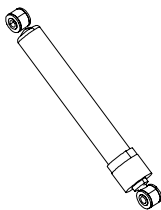

12#
1 PIÈCE

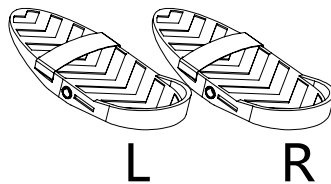





18#
1 PIÈCE

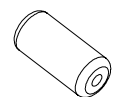

19#
1 PIÈCE





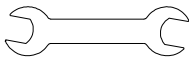

24#
4 PIÈCES

N°	QUINCAILLERIE & OUTILS	QTY
39	 M8x65	2 PIÈCES
40	 8x19	2 PIÈCES
41	 M8	2 PIÈCES
42	 M8	2 PIÈCES
49	 13x14	1 PIÈCE

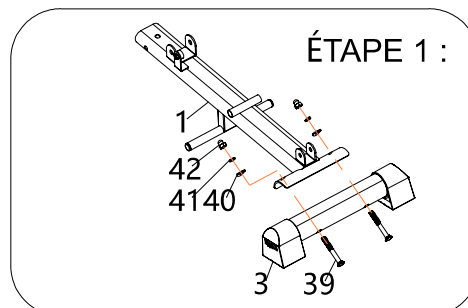
ÉTAPE 1 :

1. Connectez 3 et 1 avec 39, 40, 41, et 42 comme indiqué dans l'illustration, puis serrez-les avec la clé 49 #.





N°	MATÉRIEL & OUTILS	QTY
46	 M6x14	4 PIÈCES
47	 6x13	4 PIÈCES
21	 8x25	2 PIÈCES
48	 S5	1 PIÈCE

ÉTAPE 2 :

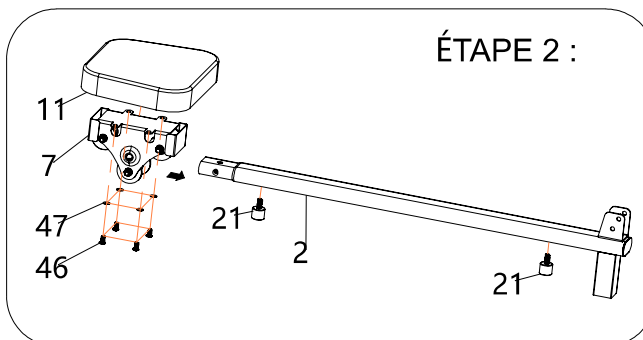
1. Connectez 11 et 7 avec 46 et 47, et verrouillez-les avec 48 #;
 2. Insérez ensuite les pièces 2 à 2 dans le sens de la flèche;
 3. Fixez 21 avec 32 sur 2.





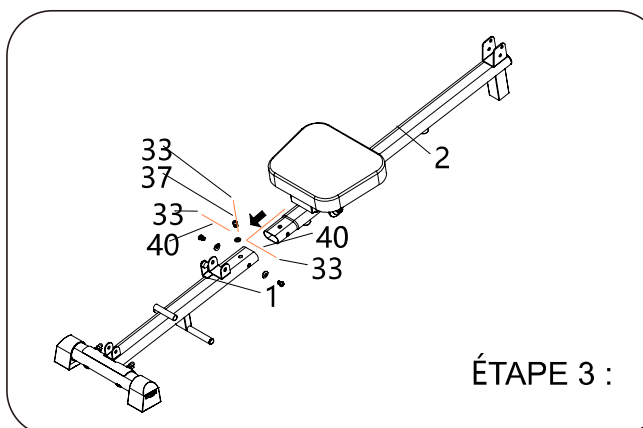

N°	HARDWARE & TOOLS	QTY
33	 M8x12	3 PIÈCES
37	 8x16	1 PIÈCE
40	 8x19	2 PIÈCES

ÉTAPE 3 :

1. Selon l'illustration, insérez 2 dans 1, alignez avec le trou, et connectez avec 33, 37, et 40. Connectez et verrouillez avec 48.



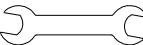



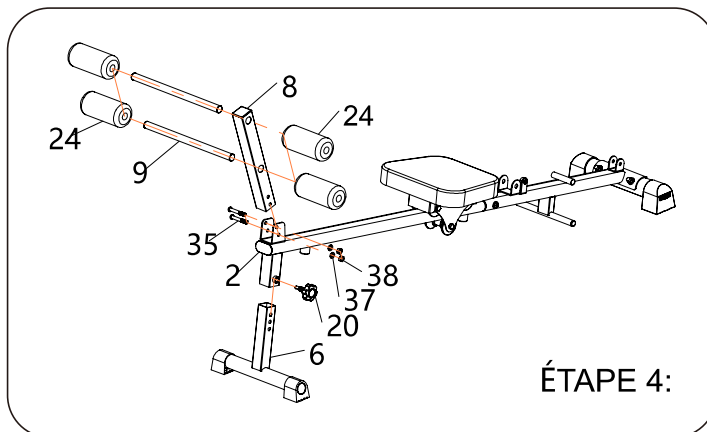

N°	MATÉRIEL & OUTILS	QTY
20	 M12x40	1 PIÈCE
35	 M8X55	2 PIÈCES
37	 8x16	2 PIÈCES
38	 M8	2 PIÈCES
48	 S5	1 PIÈCE
49	 13x14	2 PIÈCES

ÉTAPE 4:

1. Insérez 6 dans 2, alignez avec le trou, connectez avec 20, et verrouillez avec 20.
2. Connectez 8 et 2 avec 35, 37, et 38, et verrouillez-les avec 48 # et 49 #.
3. Insérez le 24 gauche dans le 9, puis insérez le 8, et enfin insérez le 24 droit.



N°	MATÉRIEL & OUTILS	QTY
33	 M8x12	2 PIÈCES
34	 M8X40	2 PIÈCES
37	 8x16	4 PIÈCES
38	 M8	2 PIÈCES
43	 M10x60	1 PIÈCES
44	 10x20	1 PIÈCES
45	 M10	1 PIÈCES

ÉTAPE 5:

1. Connectez 4 et 1 avec 43, 44 et 45, et verrouillez-les avec 49# ;
2. Connectez 12 aux bornes 1 et 4 avec les fils 34, 37 et 38 respectivement, puis verrouillez-les avec 48# et 49# ;
3. Insérez 5 dans 4 et verrouillez-le avec 33 et 37, puis serrez-le avec 48#.

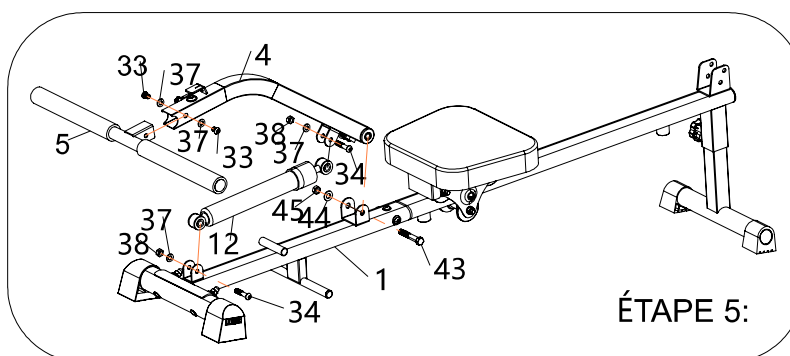

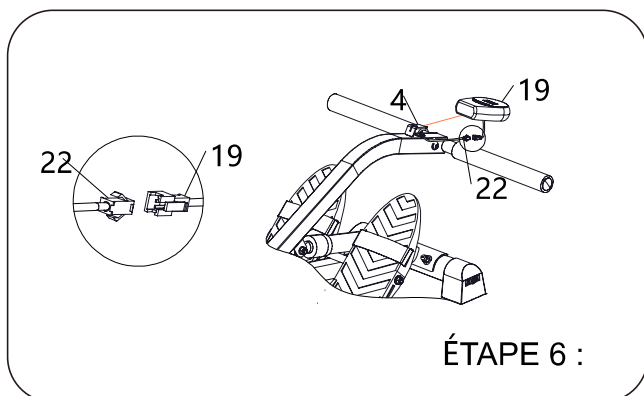

ÉTAPE 6 :

1. Insérez 19 dans 4, fixez-le, puis connectez 19 à la prise de fil 33.

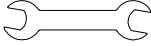

*** L'affichage de l'instrument comprend 2 piles AA 1,5 V.**

N°	MATÉRIEL & OUTILS	QTY
37		8x16 2 PIÈCES
38		M8 2 PIÈCES
49		13X14 2 PIÈCES

ÉTAPE 7 :

1. Connectez 18 et 10 à 1 avec 38 et 37, et verrouillez-les avec 49 #.

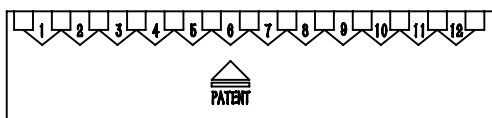
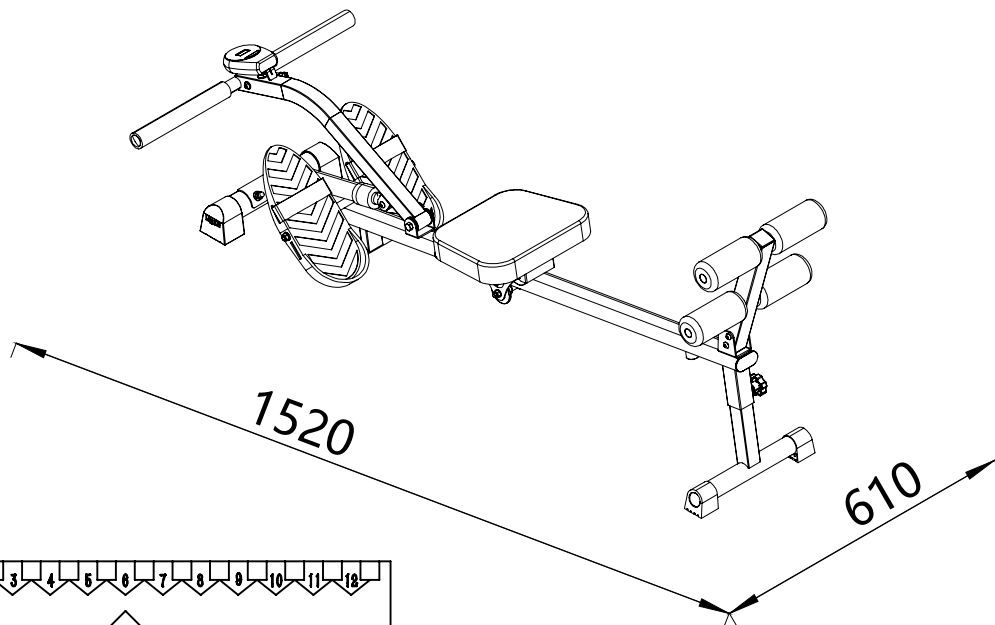
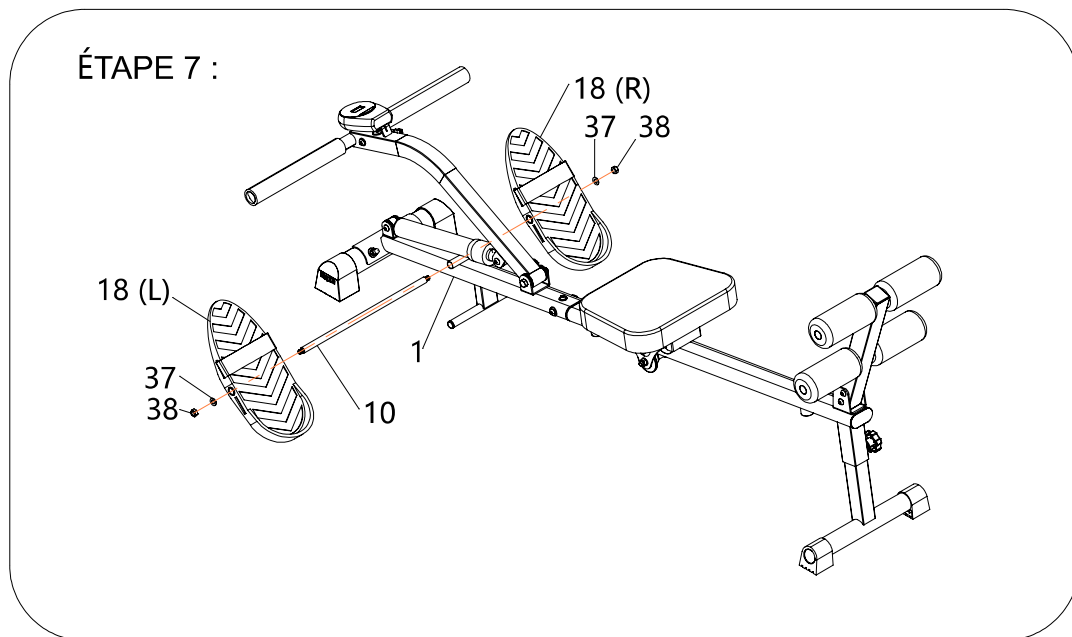

Description de la tension du cylindre hydraulique.

1. La tension hydraulique de cylindre sont divisées en 1-12 niveaux, s'étendant de petit à grand
2. La tension est la plus petite dans le 1er et la plus grande dans le 12. Lors de l'utilisation, tournez le nombre de tension Pour s'aligner avec la flèche au-dessus du brevet, et vous obtiendrez la tension correspondante.

SORGFÄLTIG LESEN!

Bitte bewahren Sie dieses Handbuch zum einfachen Nachschlagen an einem sicheren Ort auf

1. Es ist wichtig, dass Sie dieses Handbuch vor der Montage und der Inbetriebnahme des Geräts vollständig lesen. Eine sichere und effektive Verwendung kann nur erreicht werden, wenn das Gerät ordnungsgemäß montiert, gewartet und verwendet wird. Es liegt in Ihrer Verantwortung, sicherzustellen, dass die großen Benutzer des Geräts über alle Warnhinweise und Vorsichtsmaßnahmen informiert sind.
2. Bevor Sie mit einem Übungsprogramm beginnen, sollten Sie Ihren Arzt konsultieren, um festzustellen, ob Sie irgendwelche medizinischen oder körperlichen Beschwerden haben, die Ihre Gesundheit und Sicherheit gefährden oder Sie daran hindern könnten, das Gerät richtig zu benutzen. Der Rat Ihres Arztes ist unerlässlich, wenn Sie Medikamente einnehmen, die Ihre Herzfrequenz, Ihren Blutdruck oder Ihren Cholesterinspiegel beeinflussen.
3. Achten Sie auf die Signale Ihres Körpers. Falsche oder übermäßige Übungen können Ihre Gesundheit schädigen. Hören Sie auf zu üben, wenn Sie eines der folgenden Symptome verspüren: Schmerzen, Engegefühl in der Brust, unregelmäßiger Herzschlag, extreme Kurzatmigkeit, Benommenheit, Schwindel oder Übelkeitsgefühle. Wenn Sie eines dieser Symptome verspüren, sollten Sie Ihren Arzt konsultieren, bevor Sie Ihr Übungsprogramm fortsetzen.
4. Halten Sie Kinder und Haustiere von dem Gerät fern. Das Gerät ist ausschließlich für den Gebrauch durch Erwachsene vorgesehen.
5. Verwenden Sie das Gerät auf einer festen, flachen, ebenen Oberfläche mit einer Schutzabdeckung auf Ihrem Fußboden oder Teppich. Um die Sicherheit zu gewährleisten, sollte um das Gerät herum ein Freiraum von mindestens 0,5 Metern vorhanden sein.
6. Prüfen Sie vor der Verwendung des Geräts, ob die Schrauben und Muttern fest angezogen sind.
7. Die Sicherheit des Geräts kann nur aufrechterhalten werden, wenn es regelmäßig auf Schäden und/oder Verschleiß untersucht wird.
8. Verwenden Sie das Gerät immer wie angegeben. Wenn Sie beim Zusammenbau oder bei der Überprüfung des Geräts defekte Bauteile feststellen oder während der Verwendung ungewöhnliche Geräusche vom Gerät hören, stoppen Sie sofort. Verwenden Sie das Gerät nicht, bis das Problem behoben ist.
9. Tragen Sie bei der Benutzung des Geräts geeignete Kleidung. Vermeiden Sie das Tragen von loser Kleidung, die sich im Gerät verfangen oder die Bewegung einschränken oder verhindern könnte.
10. Das Gerät hat die entsprechenden Tests und Zertifizierungen bestanden. Nur für den Heimgebrauch geeignet. Die Bremsfähigkeit ist unabhängig von der Geschwindigkeit.
11. Das Gerät ist nicht für die therapeutische Verwendung geeignet.
12. Seien Sie vorsichtig beim Anheben oder Bewegen des Geräts, um Rückenverletzungen zu vermeiden. Verwenden Sie stets geeignete Hebetekniken und/oder holen Sie bei Bedarf Hilfe.
13. Versuchen Sie NICHT, das Laufband selbst zu warten, mit Ausnahme der Wartungsarbeiten, die in diesem Handbuch beschrieben sind. Das Laufband enthält keine Teile, die vom Benutzer gewartet werden können. Wenn Sie das Laufband selbst zerlegen, erlischt nicht nur Ihre Garantie, sondern es kann auch zu schweren Verletzungen führen.

Achtung!

1. Wenn der Computer keine normalen Daten anzeigt, setzen Sie bitte die Batterie wieder ein.
2. Die Batterie muss aus dem Computer entnommen werden, um sie sicher zu entsorgen, sobald sie keine Energie mehr hat.
3. Dieses Handbuch ist auch für Geräte ohne Computer geeignet.

PFLEGE

Neutrales Reinigungsmittel kann in Wasser verdünnt, verwendet werden, mit dem feuchten Tuch vorsichtig abwischen, und dann mit einem trockenen Tuch trocknen. Verwenden Sie keine alkalischen Lösungsmittel, ätherische Öle und andere Lösungsmittel.

WARTUNG/INSPEKTION

Vermeiden Sie hohe Temperaturen, Feuchtigkeit oder direkte Sonneneinstrahlung, stellen Sie es bitte an einen gut belüfteten Ort.

Wenn Sie es nicht verwenden, klappen Sie es bitte zusammen, und legen Sie es so ab, dass Kinder es nicht berühren können.

Wenn Sie es eine Zeit lang nicht verwenden, prüfen Sie bitte die Vorsichtsmaßnahmen, bevor Sie das Produkt für die normale Verwendung verwenden.

Wenn Sie das Produkt versehentlich nass machen, verwenden Sie ein trockenes Tuch, um ein Verrutschen zu vermeiden.

Im Falle einer Fehlfunktion, Abnormalität oder eines Betriebsproblems wenden Sie sich bitte an das Unternehmen.

PRODUKTRECYCLING

Aufgrund der unterschiedlichen nationalen Recyclingvorschriften beachten Sie bitte die entsprechenden Vorschriften.

BATTERIEWARNUNG:

1. Mischen Sie keine Alkali-, Standard- (Kohle-Zink) oder wiederaufladbaren (Nickel-Cadmium) Batterien.
2. Vermischen Sie niemals alte und neue Batterien.
3. Achten Sie darauf, die Batterien mit der richtigen Polarität einzulegen.
4. Entfernen Sie die Batterien, wenn das Gerät längere Zeit nicht benutzt wird.
5. Die Versorgungsklemmen dürfen nicht kurzgeschlossen werden.
6. Beachten Sie stets die örtlichen Gesetze und Vorschriften.

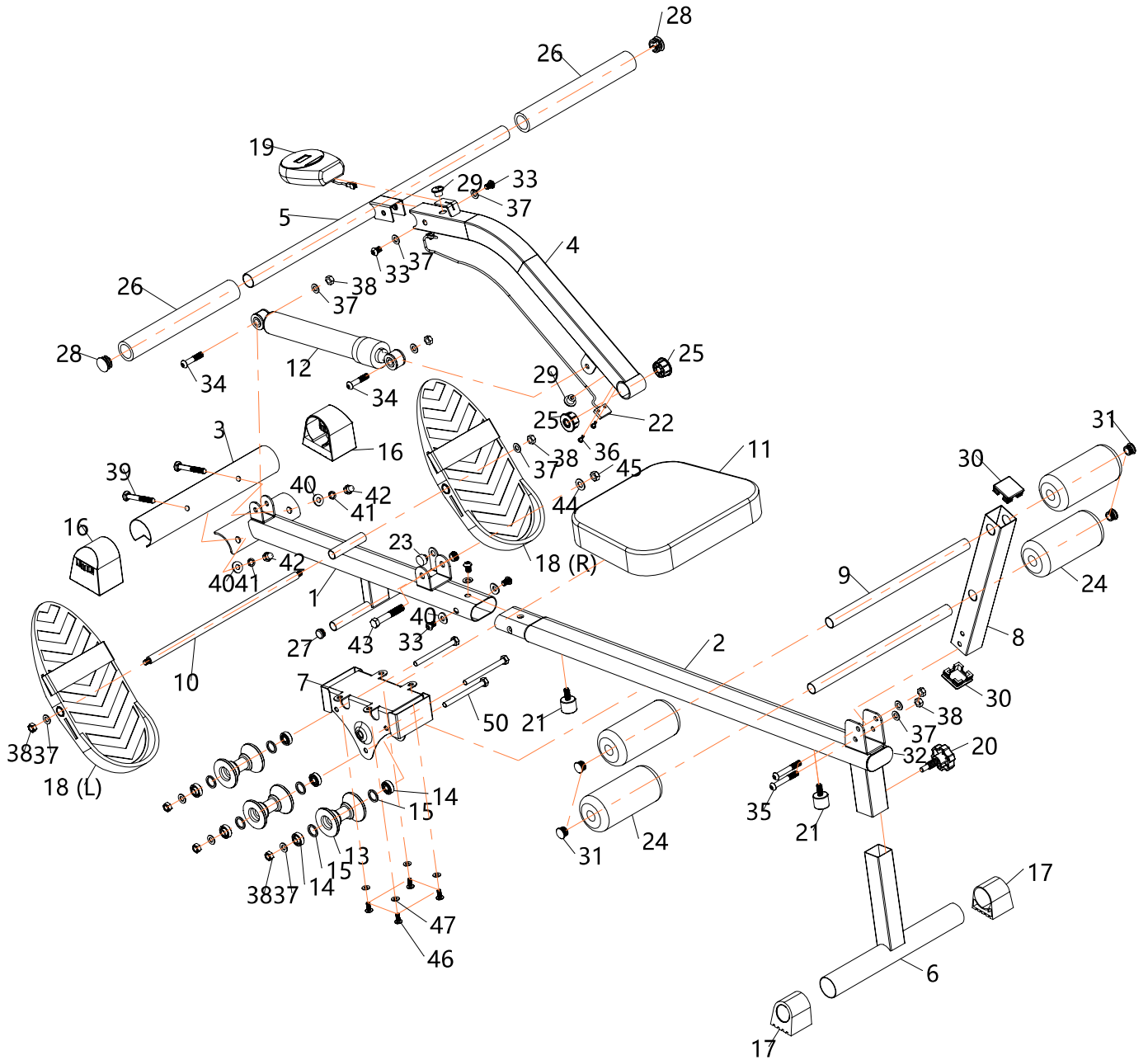

NO.	NAME	QTY
1	Vorderer Hauptrahmen	1
2	Hinterer Hauptrahmen	1
3	Vorderer Stabilisator	1
4	Der Griffhalter	1
5	Lenker	1
6	Hinterer Stabilisator	1
7	Sattelstütze	1
8	Rückrohr	1
9	Schaumstoffrohr	2
10	Achse für Pedal	1
11	Sitz	1
12	Zylinder	1
13	Rolle	3
14	Lager	6
15	Unterlegscheibe	6
16	D-förmige Endkappe $\varphi 50$	2
17	D-Typ Endkappe $\varphi 38$	2
18	Pedal (L, R)	1
19	Computer	1
20	Knopf M12x40	1
21	Pufferpolster 8x20	2
22	Sensor	1
23	Magnet	1
24	Schaumstoff $\varphi 60 \times \varphi$	4
25	Buchse	2

NO.	NAME	QTY
26	Schaum $\varphi 23 \times 5.0 \text{T} \times 250$	2
27	Rundstopfen $\varphi 16$	2
28	Rundstopfen $\varphi 25$	2
29	Drahtstecker $\varphi 12$	2
30	Quadratischer Stecker 38x38	2
31	Runder Stecker $\Phi 19$	4
32	Elliptischer Stecker 30x60	1
33	Halbrundkopf-Sechskantschraube M8X12	5
34	Halbrundkopf-Sechskantschraube M8X40	2
35	Halbrundkopf-Sechskantschraube M8X55	2
36	Rundkopf-Kreuzschlitz-Blechschrabe M4.2 \times 13	2
37	Flache Unterlegscheibe $\varphi 8 \times \varphi$ 16*1.5T	12
38	Mutter M8	9
39	Rundkopfschraube M8x65	2
40	Gewölbte Unterlegscheibe $\varphi 8 \times \varphi$ 19 *1.5T	4
41	Federring M8x2.0T	2
42	Abdeckmutter M8	2
43	Sechskantschraube M10x60	1
44	Flache Unterlegscheibe $\varphi 10 \times \varphi$ 20x1.5T	1
45	Mutter M10	1
46	Kreuzschlitz Flachkopfschraube M6x14	4
47	Flache Unterlegscheibe $\varphi 6.4 \times \varphi$ 13x1.2T	4
50	Sechskantschraube M8x90	3

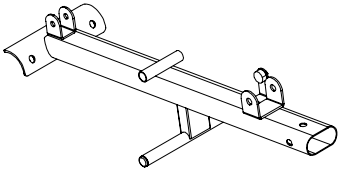

1#
1 STK

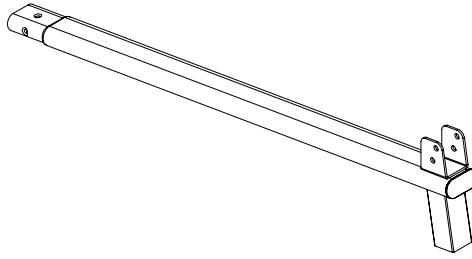

2#
1 STK

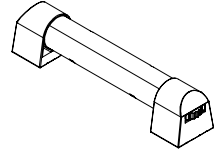

3#
1 STK

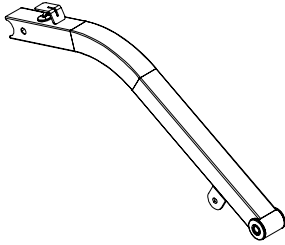

4#
1 STK

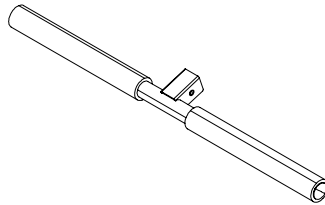

5#
1 STK

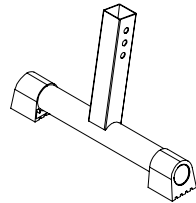

6#
1 STK

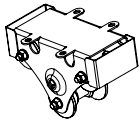

7#
1 STK

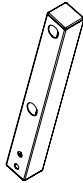

8#
1 STK

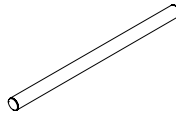

9#
2 STÜCK

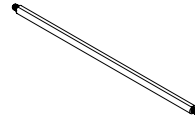

10#
1 STK

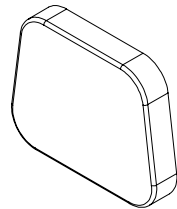

11#
1 STK

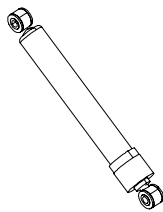

12#
1 STK







L R
18#
1 STK

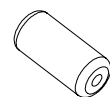

19#
1 STK





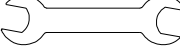

24#
4 STÜCK

Nr.	HARDWARE & WERKZEUGE	QTY
39	 M8x65	2 STÜCK
40	 8x19	2 STÜCK
41	 M8	2 STÜCK
42	 M8	2 STÜCK
49	 13x14	1 STK

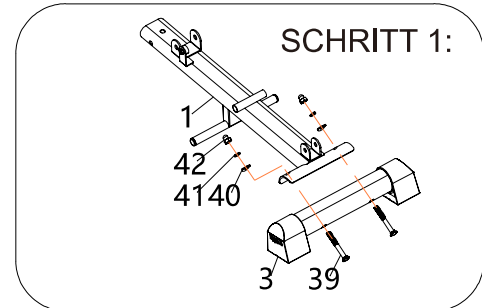
SCHRITT 1:

1. Verbinden Sie 3 und 1 mit 39, 40, 41, sowie 42 wie in der Abbildung gezeigt und ziehen Sie sie mit dem 49 # - Schlüssel fest.





Nr.	HARDWARE & WERKZEUGE	QTY
46	 M6x14	4 STÜCK
47	 6x13	4 STÜCK
21	 8x25	2 STÜCK
48	 S5	1 STK

SCHRITT 2:

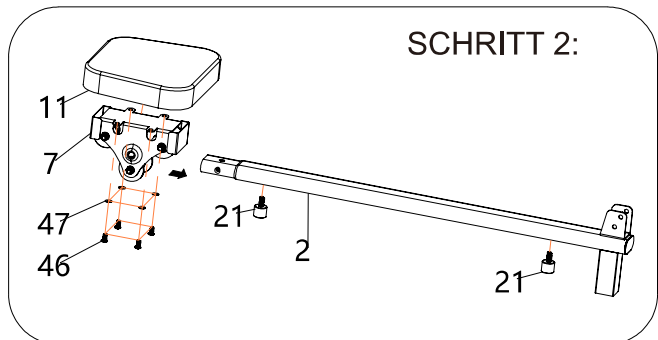
1. Verbinden Sie 11 und 7 mit 46 und 47 und sichern Sie sie mit 48 #;
2. Dann setzen Sie die Teile 2 bis 2 in Pfeilrichtung ein;
3. Befestigen Sie 21 mit 32 an 2.







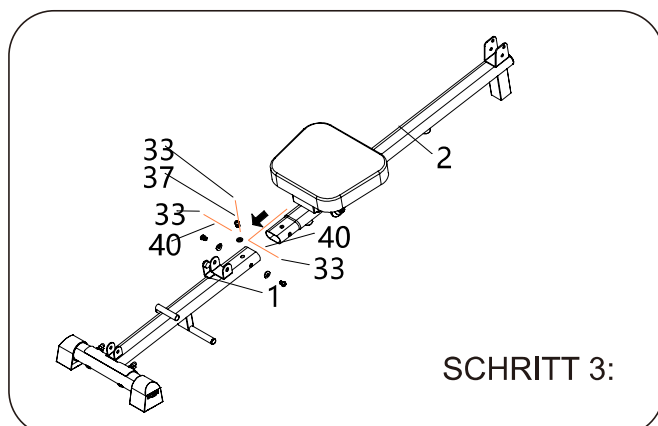

Nr.	HARDWARE & WERKZEUGE	QTY
33	 M8x12	3 STÜCK
37	 8x16	1 STK
40	 8x19	2 STÜCK

SCHRITT 3:

1. Laut der Abbildung 2 in 1 einsetzen, mit dem Loch ausrichten und mit 33, 37 und 40 verbinden. Mit 48 verbinden und verriegeln.







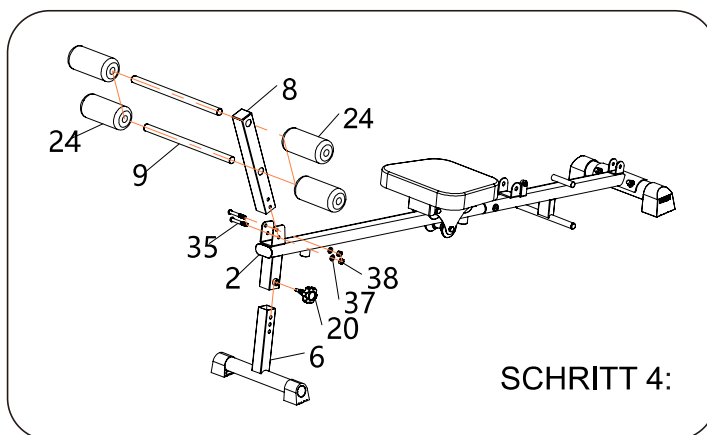

Nr.	HARDWARE & WERKZEUGE	QTY
20	 M12x40	1 STK
35	 M8X55	2 STÜCK
37	 8x16	2 STÜCK
38	 M8	2 STÜCK
48	 S5	1 STK
49	 13x14	2 STÜCK

SCHRITT 4:

1. Setzen Sie 6 in 2 ein, richten Sie es am Loch aus, verbinden Sie es mit 20 und sichern Sie es mit 20.
2. Verbinden Sie 8 und 2 mit 35, 37 und 38 und sichern Sie sie mit 48# und 49#.
3. Setzen Sie die linke 24 in 9 ein, dann setzen Sie 8 ein und anschließend die rechte 24.



Nr.	HARDWARE & WERKZEUGE	QTY
33	 M8x12	2 STÜCK
34	 M8X40	2 STÜCK
37	 8x16	4 STÜCK
38	 M8	2 STÜCK
43	 M10x60	1 STK
44	 10x20	1 STK
45	 M10	1 STK

SCHRITT 5:

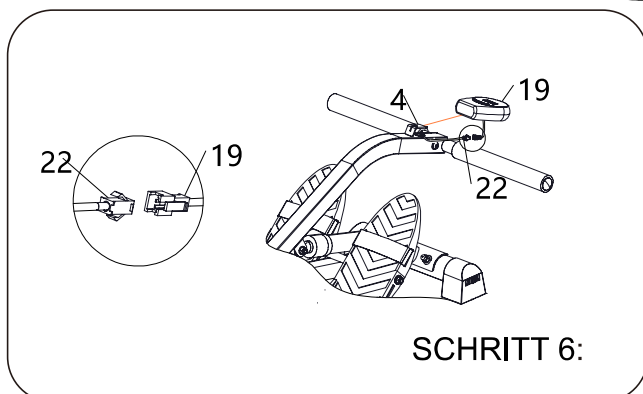
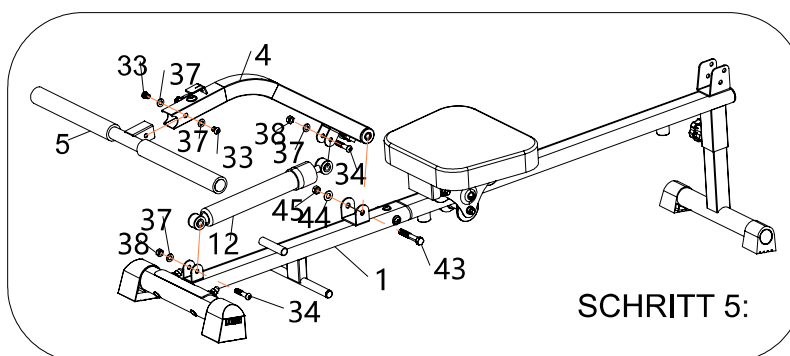

1. Verbinden Sie 4 und 1 mit 43, 44 und 45 und sichern Sie sie mit 49# ;
2. Verbinden Sie 12 mit 1 und 4 jeweils mit 34, 37 und 38 und sichern Sie sie mit 48# und 49#.
3. Stecken Sie 5 in 4 und sichern Sie es mit 33 und 37, dann ziehen Sie es mit 48# fest.



SCHRITT 6:

1. Stecken Sie 19 in 4, fixieren Sie es und verbinden Sie dann 19 mit dem 33-Drahtstecker.

*** Das Instrumentendisplay enthält 2x1,5V AA-Batterien.**

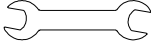
Nr.	HARDWARE & WERKZEUGE	QTY
37		8x16 2 STÜCK
38		M8 2 STÜCK
49		13X14 2 STÜCK

SCHRITT 7:

1. Verbinden Sie 18 und 10 mit 1 über 38 und 37 und sichern Sie sie mit 49 #.

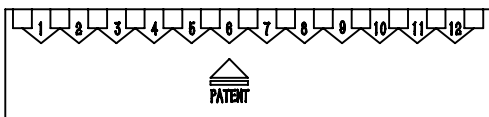
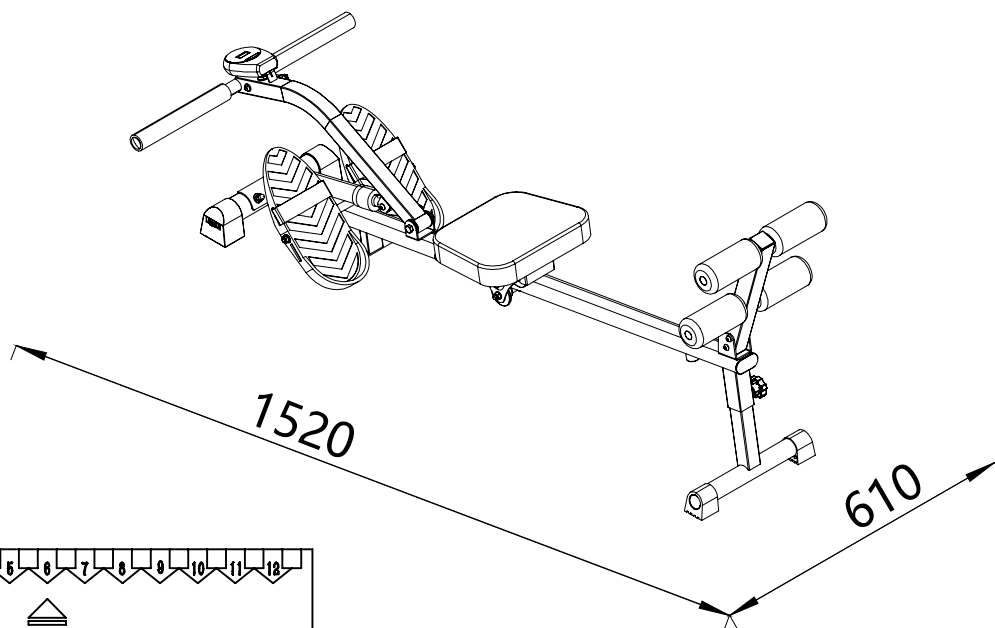
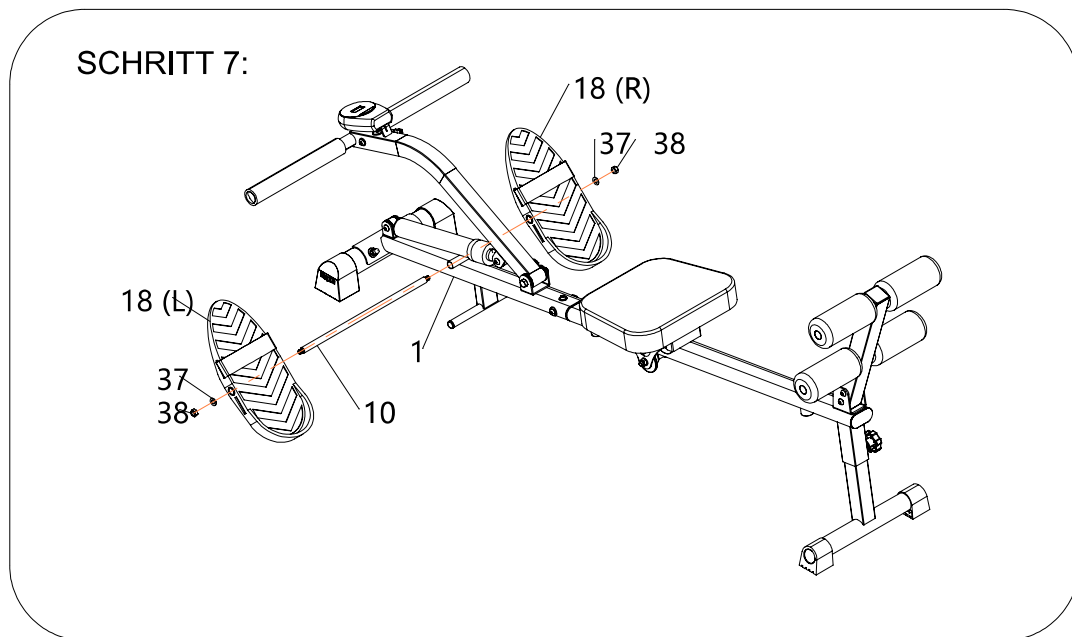

Die hydraulische anzeige der zylinder

1. Die hydraulische passung gab es zwischen 1 und 12

2. Die spannweite liegt auf der stufe 1 und die spitze auf der 12. Schwing die spannung, wann immer du sie anwenden musst. Legen sie den pfeil auf das aktenfenster, wird er ordentlich angestachelt.

LEER CUIDADOSAMENTE ESTE MANUAL!

Guarde este manual en un lugar seguro con el fin de consultarlo fácilmente en futuro.

1. Es muy importante leer todo este manual antes de instalar y utilizar este equipo. Sólo se puede lograr un uso seguro y eficaz si el equipo se instala, se mantiene y se utiliza de manera correcta. Es su responsabilidad asegurarse de que todos los usuarios altos de este equipo estén informados de todas las advertencias y precauciones.
2. Antes de empezar cualquier programa de ejercicios, debe consultar a su médico por motivo de determinar si tiene alguna condición médica o física que pueda poner en riesgo su salud y seguridad, o impedirle utilizar este equipo de manera correcta. El consejo del médico es esencial si usted está tomando algunos medicamentos que afectan su frecuencia cardíaca, presión arterial o nivel de colesterol.
3. Sea consciente de los signos de su cuerpo. Hacer ejercicio de manera incorrecta o excesiva puede dañar su salud. Deje de hacer ejercicio si experimenta alguno de los síntomas a continuación: Dolor, opresión en el pecho, latidos cardíacos irregulares, dificultad extrema para respirar, aturdimiento, mareos o náuseas. Si experimenta alguna de dichas condiciones, debe consultar a su médico antes de continuar con su programa de ejercicios.
4. Mantenga a los niños y las mascotas fuera de alcance del equipo. Sólo está diseñado para ser utilizado por los adultos.
5. Utilice el equipo sobre una superficie plana y estable con una cubierta protectora del piso o una alfombra. Con el fin de garantizar la seguridad, debe haber al menos 0,5 metros de espacio libre al alrededor del equipo.
6. Antes de utilizar este equipo, compruebe si todas las tuercas y los tornillos estén apretados firmemente.
7. La seguridad del equipo sólo se puede garantizar si lo inspecciona con regularidad por motivo de detectar daños y / o desgastes.
8. Siempre utilice el equipo como lo que se indica. Si usted encuentra algún componente defectuoso al instalar o inspeccionar el equipo, o si escucha algunos ruidos inusuales provenientes del equipo al utilizarlo, deje de utilizarlo de inmediato. No utilice el equipo hasta que se haya solucionado el problema.
9. Use ropa apropiada cuando utiliza el equipo. Evite usar ropa holgada que pueda quedar atrapada en el equipo o que pueda restringir o prevenir su movimiento.
10. El equipo ha pasado las pruebas y certificaciones pertinentes. Sólo es adecuado para uso doméstico. La capacidad de frenado es independiente de la velocidad.
11. El equipo no es adecuado para propósito terapéutico.
12. Tenga cuidado al levantar o mover el equipo por motivo de no lastimarse la espalda. Siempre utilice las habilidades apropiadas con el fin de levantar objetos y / o pida la ayuda necesaria de otras personas.
13. NO intente reparar la cinta de correr usted mismo, excepto las tareas de mantenimiento que se describen en este manual. La cinta de correr no contiene ninguna pieza que pueda reparar el usuario mismo, por lo que si usted mismo desmonta el equipo, no sólo anulará la garantía, sino también podría resultar en lesiones graves.

¡Atención!

1. Si la computadora no muestra datos de manera normal, reemplace con la batería nueva.
2. Una vez que la batería se haya agotado, Debe sacar la batería usada de la computadora y desecharla adecuadamente y seguramente.
3. Este manual también es adecuado para los equipos sin computadora.

LIMPIEZA

Puede utilizar el paño y agua diluida con detergente neutro para limpiar la bicicleta estática, limpie el aceite cuidadosamente, luego seque la bicicleta estática con un paño seco.

No utilice disolventes alcalinos, como disolventes, aceites volátiles y otros disolventes.

MANTENIMIENTO / INSPECCIÓN

Evite colocar la bicicleta estática en ambientes con altas temperaturas, la humedad o la luz solar directa, siempre colóquela en un lugar bien ventilado.

Cuando la bicicleta estática no esté en uso, pliéguelo y colóquelo en un lugar donde los niños no pueden tocar ni acceder.

Si no utilice la bicicleta estática por un tiempo largo, asegúrese de verificar las precauciones antes de utilizarla nuevamente y mantenerla que se puede utilizar normalmente.

Cuando la bicicleta estática moje accidentalmente, utilice un paño seco para limpiarla y evitar deslizamientos.

En caso de mal funcionamiento, anomalía o cualquier problema operativo, comuníquese con nuestra empresa.

RECICLAJE DE PRODUCTOS

Debido a las diferentes regulaciones nacionales sobre reciclaje, consulte las regulaciones relacionadas.

ADVERTENCIA DE BATERÍA:

1. No mezcle las pilas alcalinas, estándar (carbono-zinc) o recargables (níquel-cadmio).
2. Nunca mezcle las baterías nuevas y viejas.
3. Debe insertar las baterías con la polaridad correcta.
4. Retire las baterías cuando no se utilice la unidad durante períodos prolongados.
5. Los terminales de alimentación no deben ser cortocircuitados.
6. Siempre cumpla con las leyes y normativas locales.

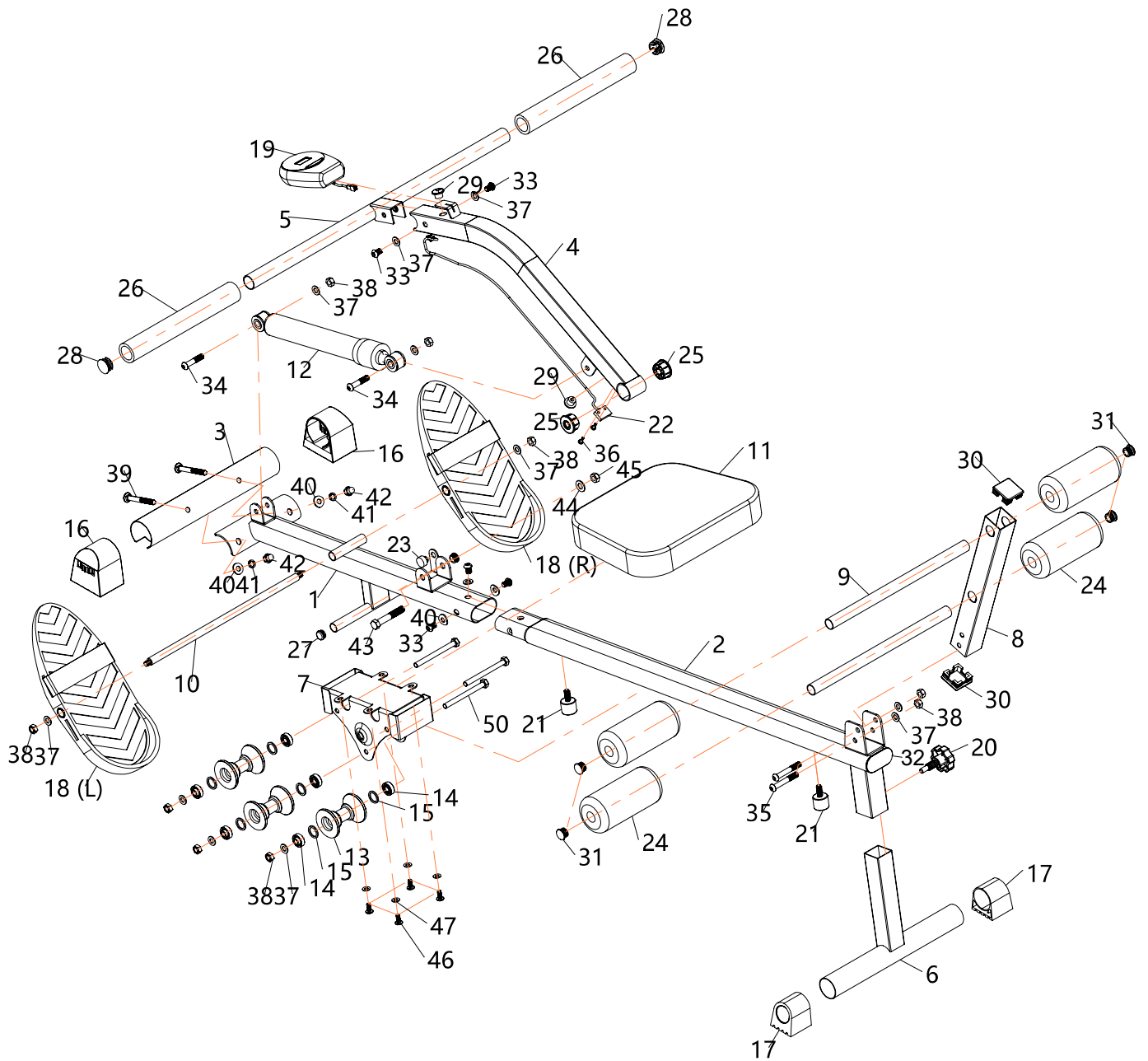

NO.	NAME	QTY
1	Marco principal delantero	1
2	Marco principal trasero	1
3	Estabilizador delantero	1
4	El soporte del manillar	1
5	Manillar	1
6	Estabilizador trasero	1
7	Tija del asiento	1
8	Tubo trasero	1
9	Tubo de espuma	2
10	Eje para pedal	1
11	Asiento	1
12	Cilindro	1
13	Rodillo	3
14	Rodamiento	6
15	Arandela	6
16	Tapa de extremo tipo D $\varnothing 50$	2
17	Tapa final tipo D $\varnothing 38$	2
18	Pedal (L, R)	1
19	Computadora	1
20	Perilla M12x40	1
21	Almohadilla de búfer 8x20	2
22	Sensor	1
23	Imán	1
24	Espuma $\varnothing 60^* \varnothing 17^* 140$	4
25	Casquillo	2

NO.	NAME	QTY
26	Espuma $\varnothing 23 \times 5.0 \text{T} \times 250$	2
27	Tapón redondo $\varnothing 16$	2
28	Tapón redondo $\varnothing 25$	2
29	Conector de cable $\varnothing 12$	2
30	Conector cuadrado 38x38	2
31	Conector redondo $\Phi 19$	4
32	Conector elíptico 30x60	1
33	Perno hexagonal de cabeza media redonda M8X12	5
34	Perno hexagonal de cabeza media redonda M8X40	2
35	Perno hexagonal de cabeza media redonda M8X55	2
36	Tornillo autorroscante de cabeza redonda con cruz M4.2 $\times 13$	2
37	Arandela plana $\varnothing 8^* \varnothing 16^* 1.5\text{T}$	12
38	Tuerca M8	9
39	Tornillo de carro M8x65	2
40	Arandela curva $\varnothing 8^* \varnothing 19^* 1.5\text{T}$	4
41	Arandela elástica M8x2.0T	2
42	Tuerca de cubierta M8	2
43	Tornillo de cabeza hexagonal M10x60	1
44	Arandela plana $\varnothing 10 \times \varnothing$	1
45	Tuerca M10	1
46	Tornillo de cabeza plana en forma de cruz M6x14	4
47	Arandela plana $\varnothing 6.4 \times \varnothing 13 \times 1.2\text{T}$	4
50	Tornillo de cabeza hexagonal M8x90	3

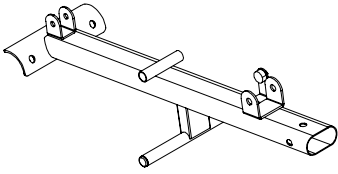

1#
1 PIEZA

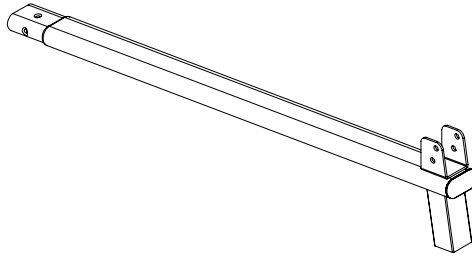

2#
1 PIEZA

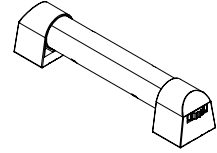

3#
1 PIEZA

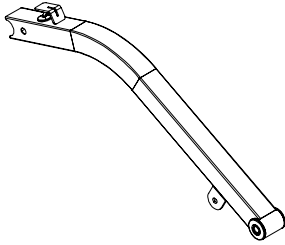

4#
1 PIEZA

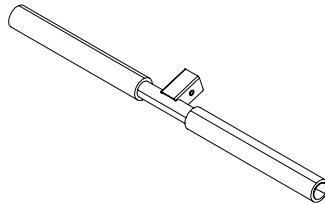

5#
1 PIEZA

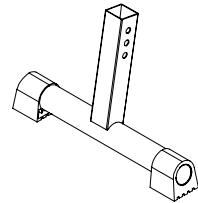

6#
1 PIEZA

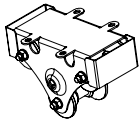

7#
1 PIEZA

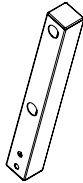

8#
1 PIEZA

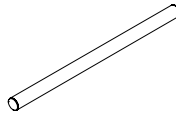

9#
2 PIEZAS

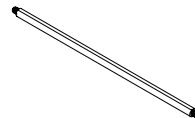

10#
1 PIEZA

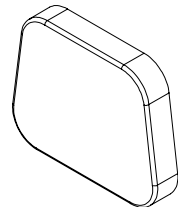

11#
1 PIEZA

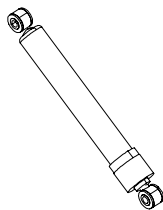

12#
1 PIEZA







L R
18#
1 PIEZA

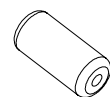

19#
1 PIEZA





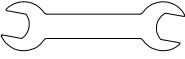

24#
4 PIEZAS

NO.	HERRAMIENTAS Y ACCESORIOS	QTY
39		M8x65 2 PIEZAS
40		8x19 2 PIEZAS
41		M8 2 PIEZAS
42		M8 2 PIEZAS
49		13x14 1 PIEZA

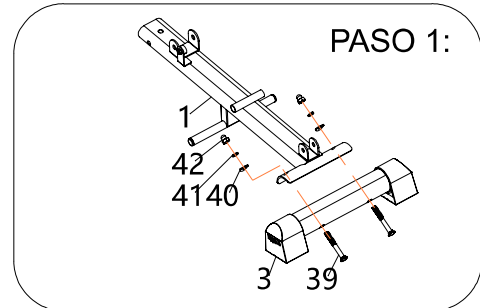
PASO 1:

1. Conecte 3 y 1 con 39, 40, 41, y 42 como se muestra en la ilustración, y apriételos con la llave 49 # .



NO.	HERRAMIENTAS Y ACCESORIOS	QTY
46		M6x14 4 PIEZAS
47		6x13 4 PIEZAS
21		8x25 2 PIEZAS
48		S5 1 PIEZA

PASO 2:

1. Conecte 11 y 7 con 46 y 47, y fíjelos con 48 #;
2. Luego inserte las piezas 2 a 2 en la dirección de la flecha;
3. Fije 21 con 32 sobre 2.

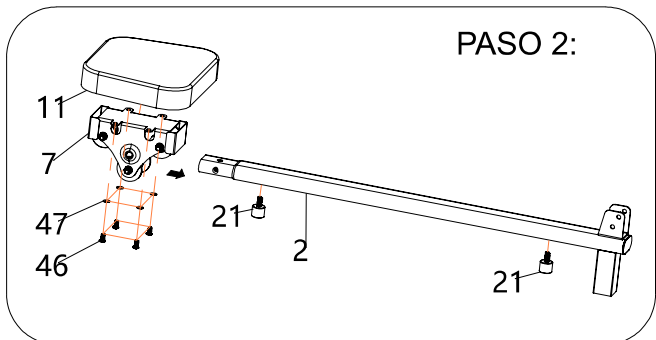



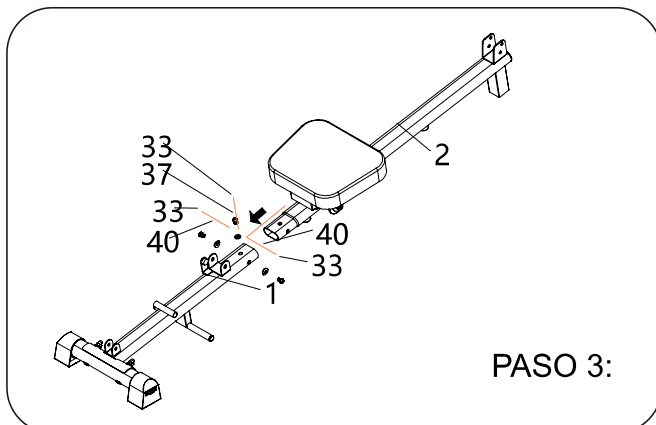

NO.	HERRAMIENTAS Y ACCESORIOS	QTY
33		M8x12 3 PIEZAS
37		8x16 1 PIEZA
40		8x19 2 PIEZAS

PASO 3:

1. Según la ilustración, inserte 2 en 1, alinee con el agujero y conecte con 33, 37 y 40. Conecte y asegure con 48.



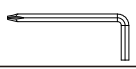
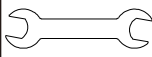



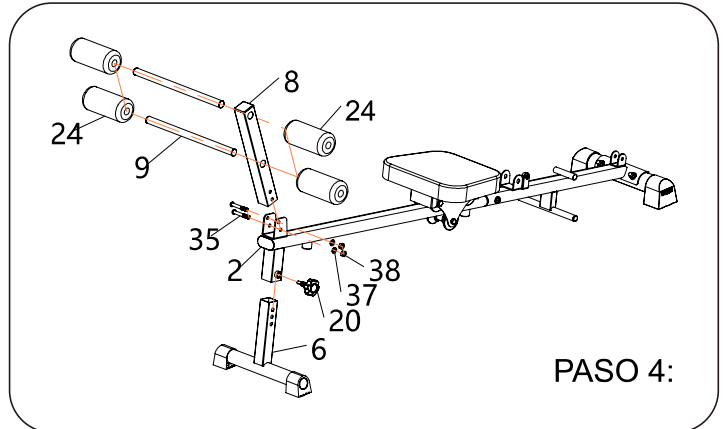

NO.	HERRAMIENTAS Y ACCESORIOS		QTY
20		M12x40	1 PIEZA
35		M8X55	2 PIEZAS
37		8x16	2 PIEZAS
38		M8	2 PIEZAS
48		S5	1 PIEZA
49		13x14	2 PIEZAS

PASO 4:

1. Inserte 6 en 2, alinee con el agujero, conecte con 20 y asegure con 20;
2. Conecte 8 y 2 con 35, 37 y 38, y asegúrelos con 48 # y 49 #;
3. Inserte el 24 izquierdo en el 9, luego inserte el 8, y después inserte el 24 derecho.



NO.	MATÉRIEL / Outils		QTY
33		M8x12	2 PIEZAS
34		M8X40	2 PIEZAS
37		8x16	4 PIEZAS
38		M8	2 PIEZAS
43		M10x60	1 PIEZA
44		10x20	1 PIEZA
45		M10	1 PIEZA

PASO 5:

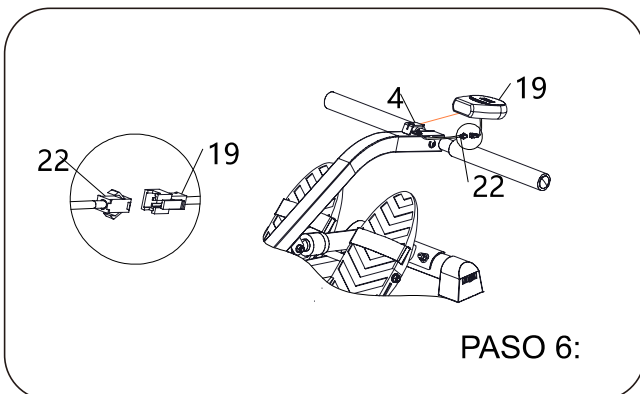
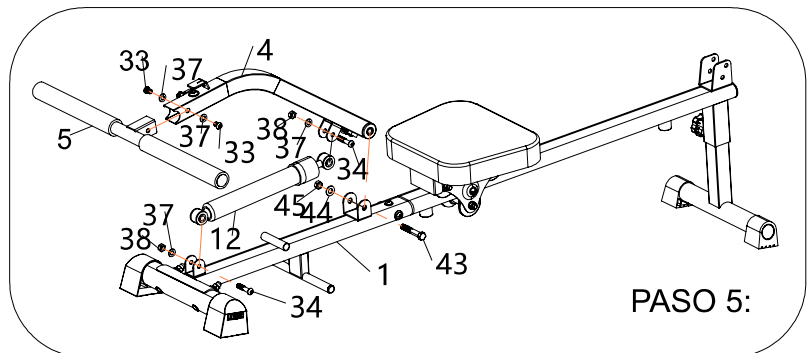

1. Conecte 4 y 1 con 43, 44 y 45, y fijelos con 49 # ;
2. Conecte 12 a 1 y 4 con 34, 37 y 38 respectivamente, y fijelos con 48# y 49#.
3. Inserte 5 en 4 y fíjelo con 33 y 37, luego apriételo con 48#.



PASO 6:

1. Inserte 19 en 4, fíjelo, y luego conecte 19 al enchufe del cable 33

*** La pantalla del instrumento incluye 2 pilas AA de 1.5V.**

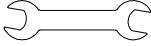
NO.	HERRAMIENTAS Y EQUIPO	QTY	
37		8x16	2 PIEZAS
38		M8	2 PIEZAS
49		13X14	2 PIEZAS

PASO 7:

1. Conecte 18 y 10 a 1 con 38 y 37, y fíjelos con 49 #.

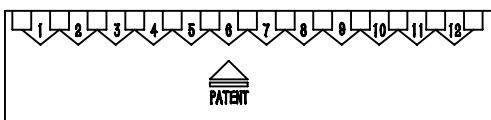
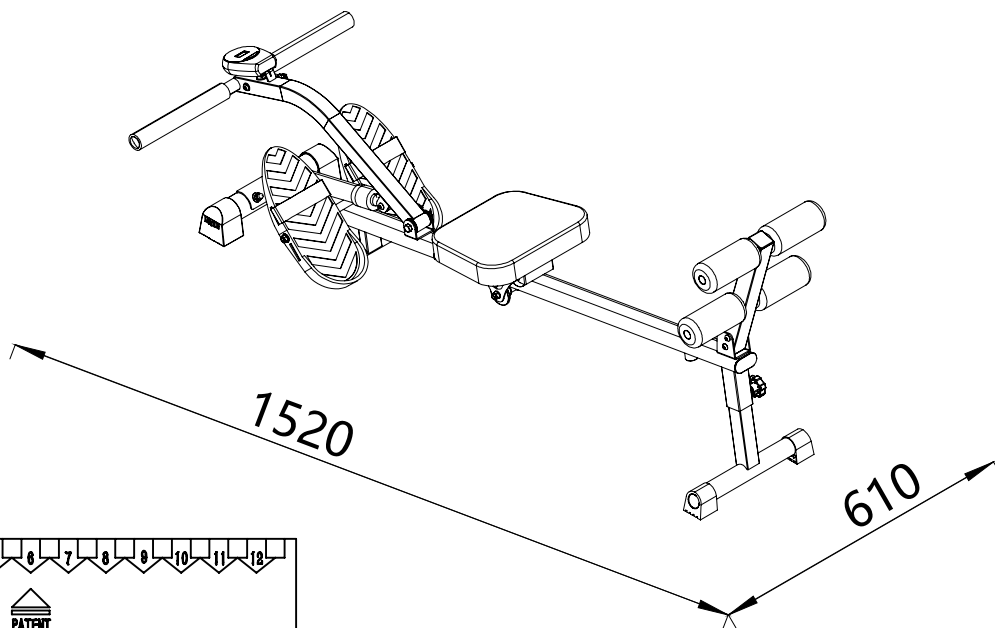
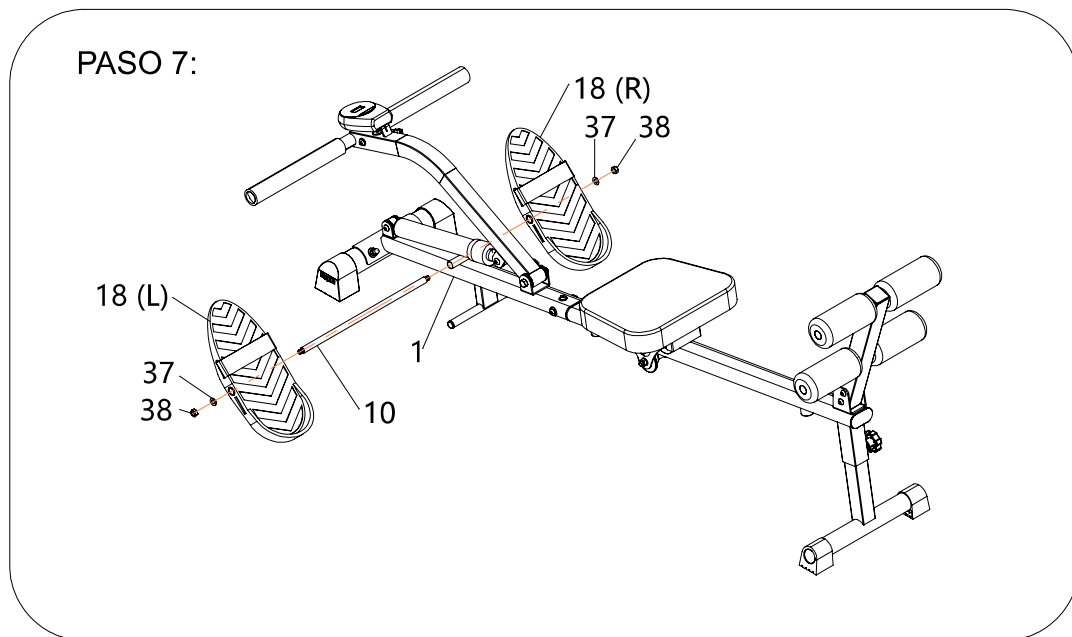

Descripción de la tensión del cilindro hidráulico:

1. La tensión del cilindro hidráulico se divide en 1-12 niveles, que van de pequeño a grande
2. La tensión es la más pequeña en la 1ª y la más grande en la 12ª. Cuando se utilice, gire el número de tensión para alinearse con la flecha por encima de la patente, y obtendrá la tensión correspondiente.

LEGGERE ATTENTAMENTE!

Conservare questo manuale in un luogo sicuro per facile riferimento futuro.

1. È importante leggere l'intero manuale prima di assemblare e utilizzare l'apparecchiatura. Un utilizzo sicuro ed efficace può essere ottenuto solo quando l'apparecchiatura è assemblata, mantenuta e utilizzata in modo corretto. È tua responsabilità assicurarti che tutti gli utenti dell'apparecchiatura siano ben informati di tutte le avvertenze e precauzioni.
2. Prima di iniziare qualsiasi programma di allenamenti, consultare il tuo medico per determinare se hai le condizioni mediche o fisiche che potrebbero mettere a rischio la salute e la sicurezza o impedire un uso corretto dell'apparecchiatura. Il consiglio del medico è essenziale se stai assumendo farmaci che influiscono sulla frequenza cardiaca, sulla pressione sanguigna o sul livello di colesterolo.
3. Devi essere consapevole dei segnali del tuo corpo. Un allenamento scorretto o eccessivo può danneggiare la tua salute. Interrompi l'allenamento se manifesti uno dei seguenti sintomi: dolore, senso di oppressione al petto, battito cardiaco irregolare, estrema mancanza di respiro, vertigini, o nausea. Se avviene una di queste condizioni, consultare il tuo medico prima di continuare il programma di allenamenti.
4. Tenere i bambini e gli animali domestici lontani dall'apparecchiatura. L'apparecchiatura è progettata esclusivamente per l'uso da parte di adulti.
5. Utilizzare l'apparecchiatura su una superficie solida e piana con una copertura protettiva sul pavimento o sul tappeto. Per garantire la sicurezza, l'apparecchiatura dovrebbe avere almeno 0,5 metri di spazio libero tutt'intorno.
6. Prima di utilizzare l'apparecchiatura, verificare che i dadi e i bulloni siano serrati saldamente.
7. La sicurezza dell'apparecchiatura può essere mantenuta solo se viene regolarmente esaminata per danni e/o usura.
8. Utilizzare sempre l'apparecchiatura secondo le istruzioni. Se si riscontrano componenti difettosi durante l'assemblaggio o il controllo dell'apparecchiatura, o se si avvertono rumori insoliti che provengano dall'apparecchiatura durante l'uso, fermati immediatamente. Non utilizzare l'apparecchiatura fino a quando il problema non è stato risolto.
9. Indossare sempre indumenti adatti durante l'utilizzo dell'apparecchiatura. Evitare di indossare indumenti larghi che potrebbero rimanere impigliati nell'apparecchiatura o che potrebbero limitare o impedire il movimento.
10. L'apparecchiatura ha superato i test e ha sostenuto le certificazioni pertinenti. Adatto solo per uso domestico. La capacità di frenata è indipendente dalla velocità.
11. L'apparecchiatura non è adatta per uso terapeutico.
12. Necessita di prestare attenzione durante il sollevamento o lo spostamento dell'apparecchiatura per non ferire la schiena. Utilizzare sempre tecniche di sollevamento adeguate e/o richiedere l'assistenza necessaria.
13. **NON** tentare di riparare il tapis roulant da soli salvo le attività di manutenzione descritte nel presente manuale. Il tapis roulant non contiene parti riparabili dall'utente, quindi smontarlo da soli non solo invaliderà la garanzia e ma anche potrebbe causare lesioni gravi.

ATTENZIONI!

1. Se lo schermo non visualizza I dati normalmente, installare di nuovo la batteria.
2. La batteria deve essere estratta dal pannello di controllo per un trattamento sicuro una volta esaurita e trattata come il rifiuto.
3. Questo manuale è adatto anche per apparecchiature senza pannello di controllo.

PULIZIA

Si può utilizzare un detergente neutro e diluirlo con acqua e pulire con il panno con attenzione l'olio, e poi asciugarlo con un panno asciutto.

Non utilizzare solventi alcalini, solventi, oli volatili e altri solventi.

MANUTENZIONE/ISPEZIONE

Evitare temperature alte, umidità o luce solare diretta, e si prega di posizionarla in un luogo ben ventilato.

Quando non è in uso, si prega di piegare l'apparecchiatura, e metterlo in un luogo dove i bambini non siano capaci di toccarla.

Se non si è usato per un periodo breve, assicurarsi di controllare le precauzioni prima di riutilizzare questo prodotto e utilizzarlo solo per un uso normale.

Quando si bagna accidentalmente il prodotto, utilizzare un panno asciutto per evitare lo slittamento.

In caso di malfunzionamento, anomalia o qualsiasi problema operativo, contattate la nostra azienda.

RICICLAGGIO DEL PRODOTTO

In considerazione delle diverse normative nazionali sul riciclaggio, si deve fare riferimento alle normative pertinenti.

AVVERTENZE SULLA BATTERIA:

1. Non mischiare batterie alcaline, standard (zinco-carbone) o ricaricabili (nichel-cadmio).
2. Non mischiare mai batterie vecchie e nuove.
3. Le batterie devono essere inserite secondo la polarità corretta.
4. Rimuovere le batterie quando l'unità non viene utilizzata a lungo.
5. I terminali della batteria non devono essere cortocircuitati.
6. Rispettare sempre le leggi e le normative locali.

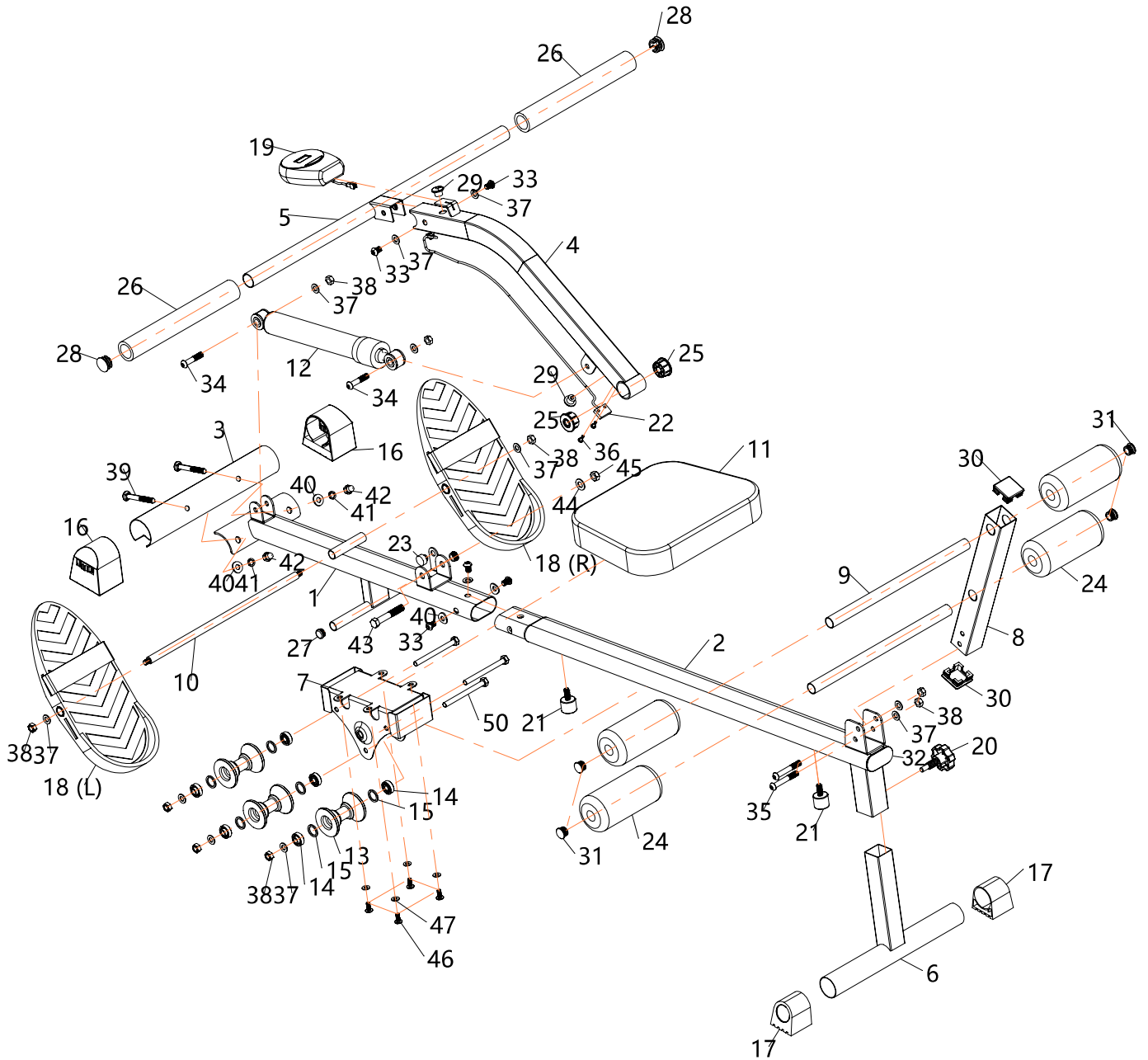

NO.	NAME	QTY
1	Telaio principale anteriore	1
2	Telaio principale posteriore	1
3	Stabilizzatore anteriore	1
4	Il supporto della maniglia	1
5	Manubrio	1
6	Stabilizzatore posteriore	1
7	Reggisella	1
8	Tubo posteriore	1
9	Tubo in schiuma	2
10	Asse per pedale	1
11	Sella	1
12	Cilindro	1
13	Rullo	3
14	Cuscinetto	6
15	Rondella	6
16	Tappo terminale di tipo D $\varnothing 50$	2
17	Tappo terminale di tipo D $\varnothing 38$	2
18	Pedale (L, R)	1
19	Computer	1
20	Manopola M12x40	1
21	Tampone buffer 8x20	2
22	Sensore	1
23	Magnete	1
24	Schiuma $\varnothing 60^* \varnothing 17^* 140$	4
25	Boccola	2

NO.	NAME	QTY
26	Schiuma $\varnothing 23 \times 5.0T \times 250$	2
27	Tappo rotondo $\varnothing 16$	2
28	Tappo rotondo $\varnothing 25$	2
29	Spina a filo $\varnothing 12$	2
30	Spina quadrata 38x38	2
31	Spina rotonda $\Phi 19$	4
32	Spina ellittica 30x60	1
33	Bullone esagonale a testa semitonda M8X12	5
34	Bullone esagonale a testa semitonda M8X40	2
35	Bullone esagonale a testa semitonda M8X55	2
36	Vite autofilettante a testa tonda con croce M4.2x13	2
37	Rondella piatta $\varnothing 8^* \varnothing 16^* 1.5T$	12
38	Dado M8	9
39	Vite a testa quadrata M8x65	2
40	Rondella curva $\varnothing 8^* \varnothing 19^* 1.5T$	4
41	Rondella elastica M8x2.0T	2
42	Dado di copertura M8	2
43	Vite a testa esagonale M10x60	1
44	Rondella piatta $\varnothing 10 \times \varnothing 20 \times 1.5T$	1
45	Dado M10	1
46	Vite a testa piatta a croce M6x14	4
47	Rondella piatta $\varnothing 6.4 \times \varnothing 13 \times 1.2T$	4
50	Vite a testa esagonale M8x90	3

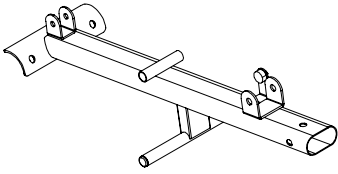

1#
1 PEZZO

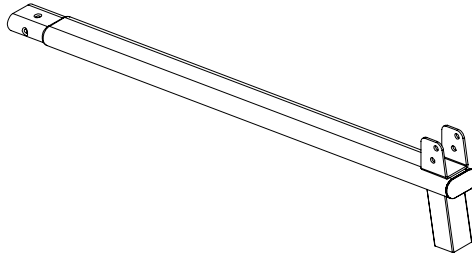

2#
1 PEZZO

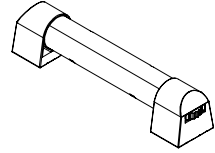

3#
1 PEZZO

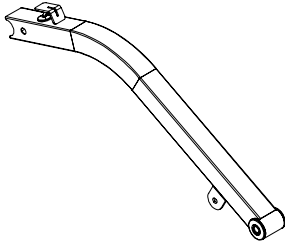

4#
1 PEZZO

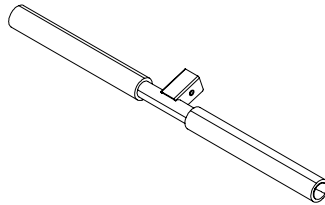

5#
1 PEZZO

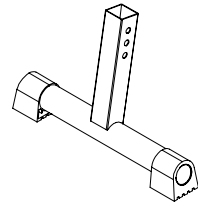

6#
1 PEZZO

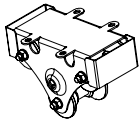

7#
1 PEZZO

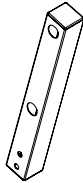

8#
1 PEZZO

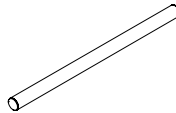

9#
2 PEZZI

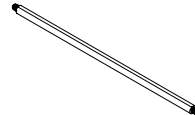

10#
1 PEZZO

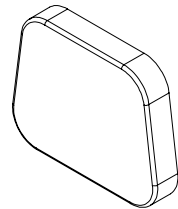

11#
1 PEZZO

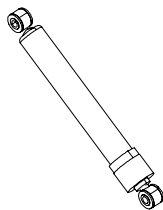

12#
1 PEZZO







L R
18#
1 PEZZO

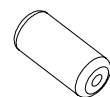

19#
1 PEZZO





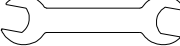

24#
4 PEZZI

NO.	FERRAMENTA E UTENSILI	QTY
39		M8x65 2 PEZZI
40		8x19 2 PEZZI
41		M8 2 PEZZI
42		M8 2 PEZZI
49		13x14 1 PEZZO

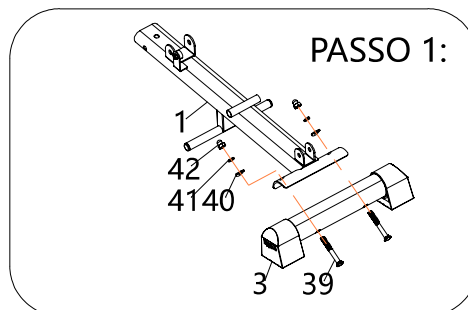
PASSO 1:

1. Collegare 3 e 1 con 39, 40, 41, e 42 come mostrato nell'illustrazione, e stringerli con la chiave 49 #.





NO.	FERRAMENTA E UTENSILI	QTY
46		M6x14 4 PEZZI
47		6x13 4 PEZZI
21		8x25 2 PEZZI
48		S5 1 PEZZO

PASSO 2:

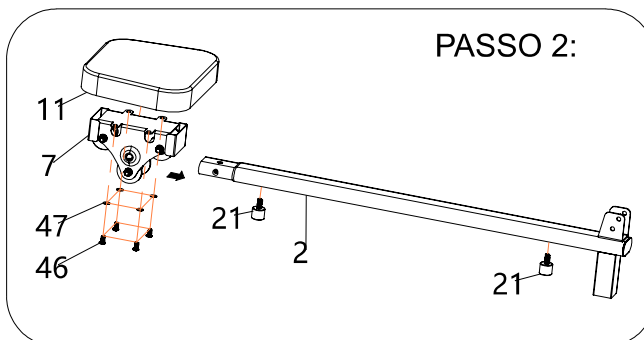
1. Collegare 11 e 7 con 46 e 47, e fissarli con 48 #;
2. Quindi inserire le parti 2 a 2 nella direzione della freccia;
3. Fissare 21 con 32 su 2.







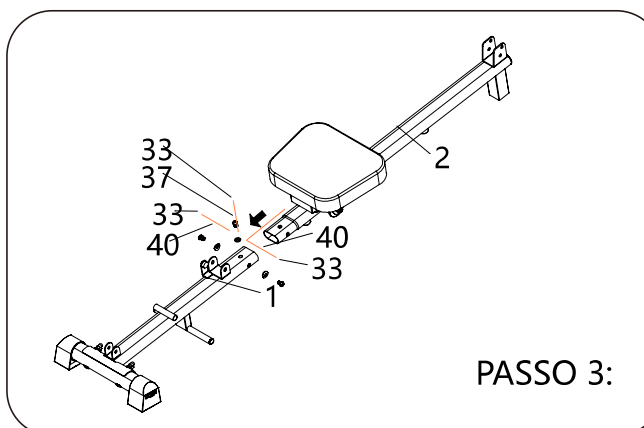

NO.	FERRAMENTA E UTENSILI	QTY
33		M8x12 3 PEZZI
37		8x16 1 PEZZO
40		8x19 2 PEZZI

PASSO 3:

1. Secondo l'illustrazione, inserire 2 in 1, allineare con il foro e collegare con 33, 37 e 40. Collegare e bloccare con 48.

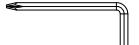





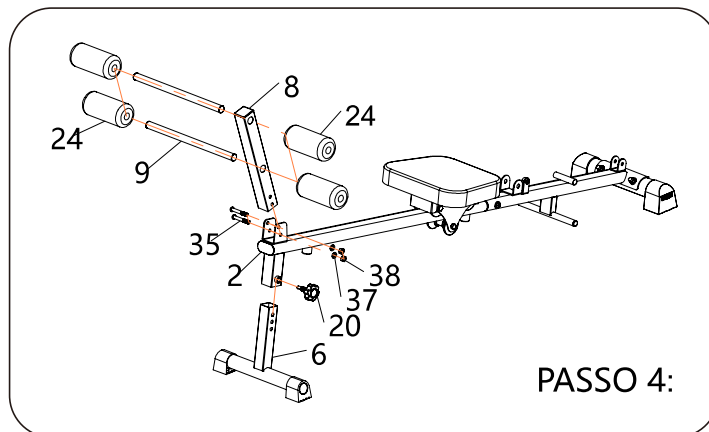

NO.	FERRAMENTA E UTENSILI	QTY
20	 M12x40	1 PEZZO
35	 M8x55	2 PEZZI
37	 8x16	2 PEZZI
38	 M8	2 PEZZI
48	 S5	1 PEZZO
49	 13x14	2 PEZZI

PASSO 4:

1. Inserire 6 in 2, allineare con il foro, collegare con 20 e fissare con 20;
2. Collegare 8 e 2 con 35, 37 e 38, e fissarli con 48# e 49#;
3. Inserire il 24 sinistro nel 9, quindi inserire l'8, e infine inserire il 24 destro.



NO.	FERRAMENTA E UTENSILI	QTY
33	 M8x12	2 PEZZI
34	 M8x40	2 PEZZI
37	 8x16	4 PEZZI
38	 M8	2 PEZZI
43	 M10x60	1 PEZZO
44	 10x20	1 PEZZO
45	 M10	1 PEZZO

PASSO 5:

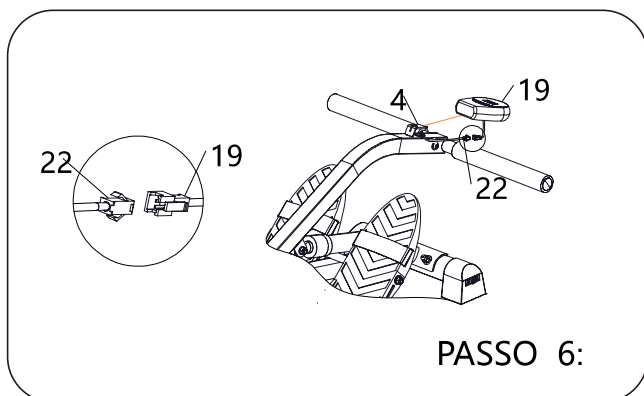
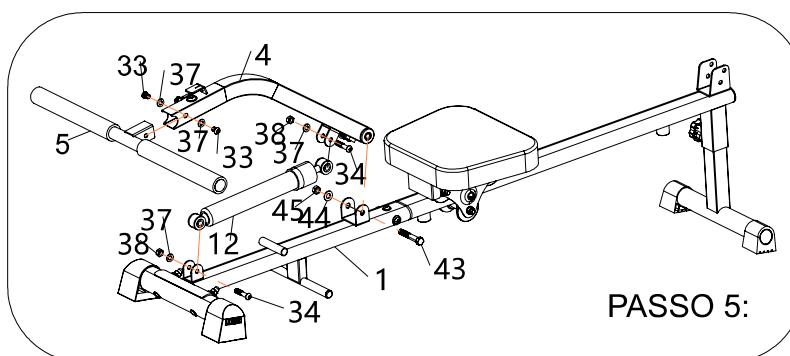

1. Collegare 4 e 1 con 43, 44 e 45, e fissarli con 49 #;
2. Collegare 12 a 1 e 4 rispettivamente con 34, 37 e 38, e fissarli con 48# e 49#.
3. Inserire 5 in 4 e fissarlo con 33 e 37, quindi stringerlo con 48#.



PASSO 6:

1. Inserire 19 in 4, fissarlo, quindi collegare 19 al connettore del filo 33.

*** Il display dello strumento include 2 batterie AA da 1,5V.**

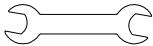
NO.	HARDWARE E STRUMENTI	QTY	
37		8x16	2 PEZZI
38		M8	2 PEZZI
49		13X14	2 PEZZI

PASSO 7:

1. Collegare 18 e 10 a 1 con 38 e 37, e bloccarli con 49 #.

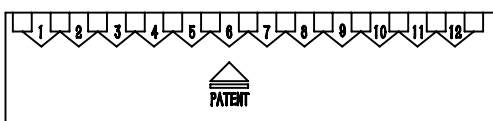
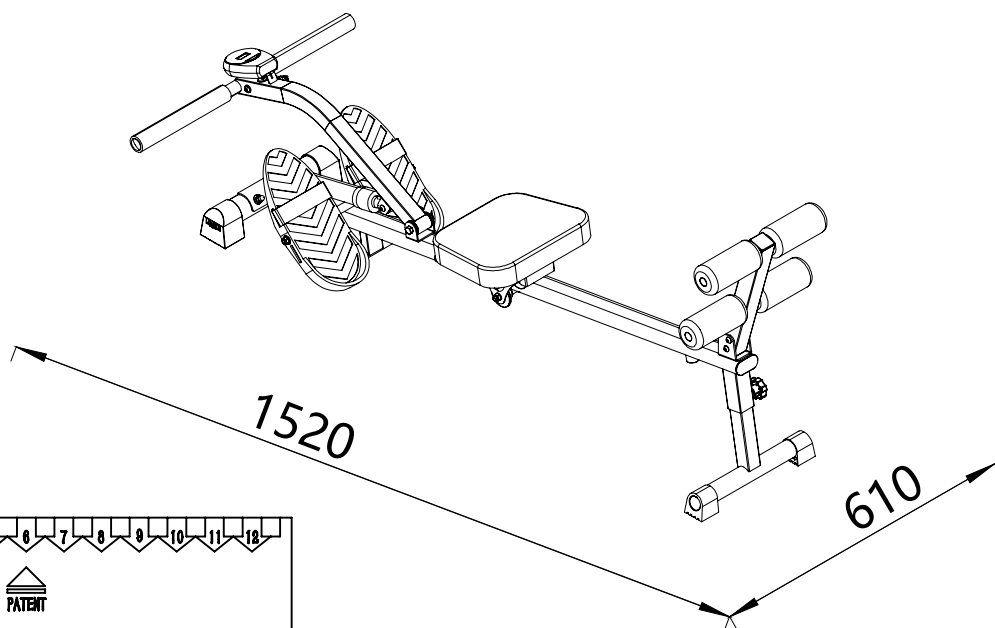
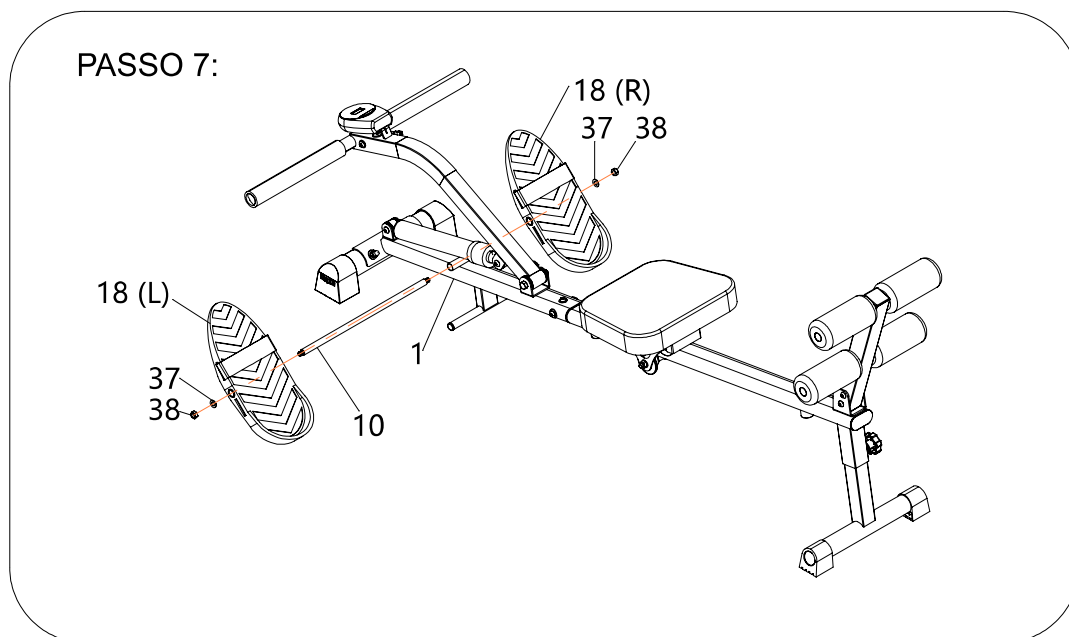

Descrizione della tensione idraulica del cilindro:

1. La tensione idraulica del cilindro è suddivisa in 1-12 livelli, da piccoli a grandi
2. La tensione è la più piccola nella prima e la più grande nella dodicesima. Quando si usa, ruotare il numero di tensione Per allinearti con la freccia sopra il brevetto, e otterrai la tensione corrispondente.

UK

If you have any questions, please contact our customer care centre.

Our contact details are below:



0044-800-240-4004



enquiries@mhstar.co.uk

IMPORTER ADDRESS:

MH STAR UK Ltd

1 Northampton Cross Logistics Park

Northampton Cross Road

Northampton

NN4 9FH

MADE IN CHINA

ES

Si tiene alguna pregunta, comuníquese con nuestro Centro de Atención al Cliente.

Nuestros datos de contacto son los siguientes:



0034-931294512



atencioncliente@aosom.es

Importador/Fabricante/REP:

Spanish Aosom, S.L.

C/ Roc Gros, nº 15. 08550, Els Hostalets de Balenyà, Spain.

B66295775

atencioncliente@aosom.es

TEL: 931294512

HECHO EN CHINA

FR

Si vous avez la moindre question, veuillez contacter notre centre d'assistance à la clientèle.

Nos coordonnées sont les suivantes:



0033-1-84166106



aosom@mhfrance.fr

Importé par/Fabricant/REP:

MH France

2, rue Maurice Hartmann

92130 Issy-les-Moulineaux

France

FABRIQUÉ EN CHINE

PT

Se tiver alguma dúvida, por favor contacte o nosso Centro de Atendimento ao Cliente.

Os nossos dados de contacto são os seguintes:



0034-931294512



info@aosom.pt.

IMPORTADOR:

SPANISH AOSOM, S.L

C.ROC GROS N.15, 08550. ELS HOSTALETES DE BALENYÀ

TEL: 931294512 (SEG-SEX DAS 7:30H ÀS 16:30H)

INFO@AOSOM.PT

WWW.AOSOM.PT

DE

Wenn Sie Fragen haben, wenden Sie sich bitte an unser Kundendienstzentrum.

Unsere Kontaktdaten stehen unten:



0049-0(40)-87408465



service@aosom.de

Importeur/Hersteller/REP:

MH Handel GmbH

Wendenstraße 309

D-20537 Hamburg

Germany

IN CHINA HERGESTELLT

IT

In caso di dubbio, si prega di contattare il nostro centro assistenza clienti.

I nostri dettagli di contatto sono di seguito:



0039-0249471447



clienti@aosom.it

IMPORTATO DA/Produttore/REP:

AOSOM Italy srl

Centro Direzionale Milanofiori

Strada 1 Palazzo F1

20057 Assago (MI)

P.I.: 08567220960

FATTO IN CINA

