

EN_IMPORTANT, RETAIN FOR FUTURE REFERENCE: READ CAREFULLY.

FR_IMPORTANT: A LIRE ATTENTIVEMENT ET A CONSERVER POUR VOUS Y REFERRER ULTERIEUREMENT

ES_IMPORTANTE, LEA DETENIDAMENTE Y GUARDE PARA FUTURAS REFERENCIAS.

PT_IMPORTANTE, GUARDE PARA FUTURA REFERÊNCIA, LEIA ATENTAMENTE.

DE_WICHTIG! SORFGFÄLTIG LESEN UND FÜR SPÄTERES NACHSCHLAGEN AUFBEWAHREN.

IT_IMPORTANTE, LEGGERE E CONSERVARE QUESTO MANUALE D'ISTRUZIONE PER UN USO FUTURO.

RO_IMPORTANT, DE PĂSTRAT PENTRU REFERINȚE VIITOARE: CITIȚI CU ATENȚIE.

IMPORTANT, RETAIN FOR FUTURE REFERENCE: READ CAREFULLY.

Only for domestic use

Instructions for use:

- *Put the chair stably on a flat floor.
- *Stay away from open flames.
- *Avoid the overload at the chair.

Precautions before assembly:

- *Prepare a clean and dry mounting area.
- *Verify that the product is not damaged.
- *Check that none of the pieces are missing.

Maintenance:

- *Clean with a soft fabric.
- *Check the seating regularly.

Storage conditions:

- *The fabric should be stored completely dry, in a clean and dry place to avoid the risks of mold.

Beware of crushing and cutting hazards during assembly.

The manufacturer declines all responsibility in case of damages due to a bad installation or withering.

Warning! Only trained personnel may replace or repair components for height adjustment of seating furniture with energy storage.

If the product has electrical parts:

This appliance can be used by children aged from 8 years and above and persons with reduced physical, sensory or mental capabilities or lack of experience and knowledge if they have been given supervision or instruction concerning use of the appliance in a safe way and understand the hazards involved.

Children shall not play with the appliance.

Cleaning and user maintenance shall not be made by children without supervision.

The appliance is only to be used with the power supply unit provided with the appliance.

The external flexible cable or cord of this transformer cannot be replaced; if the cord is damaged, the transformer shall be scrapped.

If The appliance has a heated surface. Persons insensitive to heat must be careful when using the appliance.



The power supply unit shall not be used, if pins of the plug part are damaged.

IMPORTANT: A LIRE ATTENTIVEMENT ET À CONSERVER POUR CONSULTATION ULTÉRIEURE.

Réservé à un usage domestique

Conseils :

- *Placez la chaise sur un sol plat et sec afin qu'elle soit stable
- *Placer à l'écart des flammes ou de sources de chaleur
- *Ne pas dépasser la charge maximale autorisée

Précautions avant l'assemblage :

- *Préparez une zone de montage propre et sèche
- *Vérifiez que le produit n'est pas endommagé
- *Vérifiez qu'aucune des pièces de ne manque

Recommandations d'entretien :

- *Veuillez utiliser un chiffon doux pour essuyer la chaise
- *Vérifiez régulièrement la structure du produit

Conditions de stockage:

- *Veuillez stocker le produit dans un environnement propre et sec pour éviter tout risque de moisissure.

Veillez faire attention à ne pas vous blesser lors de l'assemblage du produit. Le fabricant n'est pas responsable des dommages causés par une mau-vaie installation.

Attention! Le remplacement et la réparation des pièces pour le réglage de la hauteur du fauteuil avec accumulateurs d'énergie ne doivent être effectués que par du personnel qualifié.

Si le produit comporte des pièces électriques :

Cet appareil peut être utilisé par des enfants à partir de 8 ans et plus et par des personnes ayant des capacités physiques, sensorielles ou mentales réduites ou un manque d'expérience et de connaissances à condition qu'elles aient reçu une supervision ou des instructions concernant l'utilisation de l'appareil en toute sécurité et qu'elles comprennent les dangers encourus.

Les enfants ne doivent pas jouer avec l'appareil.

Le nettoyage et l'entretien par l'utilisateur ne doivent pas être effectués par des enfants sans surveillance.

L'appareil doit être utilisé uniquement avec l'alimentation fournie avec l'appareil.

Le câble souple externe de ce transformateur ne peut pas être remplacé; en cas d'endommagement du cordon, le transformateur doit être mis au rebut.

Si L'appareil comporte une surface chaude. Les personnes insensibles à la chaleur doivent être prudentes lorsqu'elles utilisent l'appareil.



Le bloc d'alimentation ne doit pas être utilisé si les broches de la partie fiche sont endommagées.

IMPORTANTE: LEA Y GUARDE PARA FUTURAS REFERENCIAS.

Producto para uso doméstico

Consejos de uso:

- *Coloque el producto sobre un suelo plano de forma estable.
- *Manténgase alejado de fuentes de calor y llamas.
- *Evite la sobrecarga de los anclajes del producto.

Precauciones antes del montaje:

- * Prepare la zona de montaje. Asegúrese de que esté limpia y seca.
- * Asegúrese de que el producto está en buen estado.
- * Verifique que no falta ninguna de las piezas.

Mantenimiento:

- *Limpie el producto con la ayuda de un paño suave.
- *Inspeccione el producto de forma regular a fin de detectar posibles daños o desperfectos que puedan afectar a su uso.

Condiciones de almacenaje:

- *A fin de evitar la aparición de moho, los tejidos se deben de guardar totalmente secos y en un lugar limpio y sin humedad.

Atención:

Riesgo de pinzamientos o cortes durante el montaje.

El fabricante declina toda responsabilidad en caso de deterioro debido a una mala instalación o por causar meteorológicas.

¡Advertencia! La sustitución y la reparación de los componentes para la regulación de la altura de la silla con acumuladores de energía deben ser efectuados solo por personal cualificado.

Si el producto tiene partes eléctricas:

Este aparato puede ser utilizado por niños a partir de 8 años y personas con capacidades físicas, sensoriales o mentales reducidas o con falta de experiencia y conocimientos si han recibido supervisión o instrucciones sobre el uso del aparato de forma segura y comprenden los peligros que conlleva.

Los niños no deben jugar con el aparato.

Los niños no deben limpiar ni realizar tareas de mantenimiento sin supervisión.

El aparato sólo debe utilizarse con la fuente de alimentación suministrada con el mismo.

El cable flexible externo o cordón de este transformador no puede ser reemplazado; si el cordón está dañado, el transformador debe ser desechado.

Si el aparato tiene una superficie caliente. Las personas insensibles al calor deben tener cuidado al utilizar el aparato.



No utilice la fuente de alimentación si las clavijas del enchufe están dañadas.

IMPORTANTE, RETER PARAREFERÊNCIA FUTURA: LEIA ATENTAMENTE.

Produto para uso doméstico

Conselhos de uso:

- * Coloque o produto sobre um solo plano e estável.
- * Mantenha-o afastado de fontes de calor e chamas.
- * Evite a sobre carga das fixações do produto.

Precauções antes da montagem:

- * Prepare a zona de montagem. Certifique-se de que esteja limpa e seca.
- * Certifique-se que o produto esteja em bom estado.
- * Verifique que não falte nenhuma das peças.

Manutenção:

- * Limpar o produto com a ajuda de um pano suave.
- * Inspeccionar o produto de forma regular a fim de detectar possíveis defeitos que possa afetar seu uso.

Condições de armazenamento:

- * A fim de evitar a aparecimento de mofo, os tecidos se devem guardar totalmente secos e em um lugar limpo e sem umidade.

Atenção:

Risco de cortes durante a montagem. O fabricante declina toda responsabilidade no caso de deterioração devido uma má instalação ou por causas meteorológicas.

Aviso! A substituição ou reparação de componentes para a regulação em altura de mobiliário para sentar com acumulador de energia só pode ser efectuada por pessoal qualificado.

Se o produto tiver partes eléctricas:

Este aparelho pode ser utilizado por crianças a partir dos 8 anos de idade e por pessoas com capacidades físicas, sensoriais ou mentais reduzidas ou com falta de experiência e conhecimentos, desde que tenham recebido supervisão ou instruções sobre a utilização do aparelho de forma segura e compreendam os perigos envolvidos.

As crianças não devem brincar com o aparelho.

A limpeza e a manutenção pelo utilizador não devem ser efectuadas por crianças sem supervisão.

O aparelho só deve ser utilizado com a fonte de alimentação fornecida com o aparelho.

O cabo flexível externo ou o cabo deste transformador não podem ser substituídos; se o cabo estiver danificado, o transformador deve ser eliminado.

Se O aparelho tem uma superfície aquecida. As pessoas insensíveis ao calor devem ter cuidado ao utilizar o aparelho.

A fonte de alimentação não deve ser utilizada se os pinos da ficha estiverem danificados.



WICHTIG! SORGFÄLTIG LESEN UND ZUM SPÄTEREN NACHSCHLAGEN AUFBEWAHREN.

Ausschließlich für den häuslichen Gebrauch bestimmt

Nutzungshinweise:

- *Bitte stellen Sie den Stuhl stabil auf eine ebene Fläche.
- *Von offenen Feuerquellen fernhalten.
- *Vermeiden Sie eine Überlastung des Stuhls.

Vorsichtsmaßnahmen vor der Montage:

- *Bitte bereiten Sie einen sauberen und trockenen Montagebereich vor.
- *Stellen Sie sicher, dass das Produkt nicht beschädigt ist.
- *Vergewissern Sie sich, dass kein Zubehörteil fehlt.

Instandhaltung:

- *Bitte reinigen Sie den Stuhl nur mit einem weichen Tuch.
- *Überprüfen Sie den Stuhl regelmäßig.

Lagerung:

- *Der Stoff sollte an einem völlig trockenen und sauberen Ort aufbewahrt werden, um Schimmel zu vermeiden.

Vorsicht vor Quetsch- und Schnittgefahr bei der Montage.
Der Hersteller lehnt jegliche Haftung für Schäden ab, die aufgrund unsachgemäßer Montage oder Witterungseinflüsse verursacht werden.
Warnung! Der Austausch und die Reparatur von Zubehörteilen zur Einstellung der Stuhlhöhe darf nur von qualifiziertem Fachpersonal durchgeführt werden.

Wenn das Produkt elektrische Teile enthält:

Dieses Gerät kann von Kindern ab 8 Jahren und darüber sowie von Personen mit verringerten physischen, sensorischen oder mentalen Fähigkeiten oder Mangel an Erfahrung und Wissen benutzt werden, wenn sie beaufsichtigt oder bezüglich des sicheren Gebrauchs des Gerätes unterwiesen wurden und die daraus resultierenden Gefahren verstehen. Kinder dürfen nicht mit dem Gerät spielen.

Reinigung und Benutzer-Wartung dürfen nicht von Kindern ohne Beaufsichtigung durchgeführt werden.

Das Gerät ist nur mit dem mitgelieferten Netzteil zu benutzen.

Das externe flexible Kabel dieses Transformators kann nicht ersetzt werden; Wenn das Kabel beschädigt ist, muss der Transformator verschrottet werden.

Wenn Das Gerät hat eine beheizte Oberfläche. Hitzeunempfindliche

Personen müssen bei der Verwendung des Geräts vorsichtig sein.
Das Netzteil darf nicht verwendet werden, wenn die Stifte des Steckerteils beschädigt sind.



IMPORTANTE! CONSERVARE IL PRESENTE MANUALE PER FUTURO RIFERIMENTO E LEGGERLO ATTENTAMENTE.

Solo per uso domestico

Istruzioni per l'uso:

- *Posizionare la sedia in maniera stabile su un pavimento in piano.
- *Tenere lontano dalle fiamme vive.
- *Evitare di sovraccaricare la sedia.

Precauzioni prima del montaggio:

- *Preparare un'area di montaggio sgombra e asciutta.
- *Verificare che il prodotto non sia danneggiato.
- *Verificare che non manchi nessun pezzo.

Manutenzione:

- *Pulire con un tessuto morbido.
- *Controllare regolarmente il sedile.

Condizioni di stoccaggio:

- *Il tessuto deve essere conservato completamente asciutto, in un luogo pulito e asciutto per evitare la formazione di muffa.

Fare attenzione al rischio di schiacciamento e di taglio durante le fasi di montaggio.

Il produttore declina ogni responsabilità in caso di danni dovuti ad un'installazione incorretta o alle intemperie.

Avvertenza! La sostituzione e la riparazione di componenti per la regolazione dell'altezza della sedia con un sistema di propulsione va eseguita solo da personale qualificato.

Se il prodotto ha parti elettriche:

Questo apparecchio può essere utilizzato da bambini di età pari o superiore a 8 anni e da persone con ridotte capacità fisiche, sensoriali o mentali o con mancanza di esperienza e conoscenza, a condizione che abbiano ricevuto supervisione o istruzioni sull'uso dell'apparecchio in modo sicuro e che comprendano i rischi connessi.

I bambini non devono giocare con l'apparecchio.

La pulizia e la manutenzione da parte dell'utente non devono essere eseguite da bambini senza supervisione.

L'apparecchio deve essere utilizzato solo con l'alimentatore fornito in dotazione.

Il cavo flessibile esterno o il cavo di questo trasformatore non possono essere sostituiti; se il cavo è danneggiato, il trasformatore deve essere rottamato.

Se l'apparecchio ha una superficie riscaldata. Le persone insensibili al calore devono prestare attenzione quando utilizzano l'apparecchio.



L'alimentatore non deve essere utilizzato se gli spinotti della spina sono danneggiati.

IMPORTANT, PĂSTRAȚI PENTRU REFERINȚE VIITOARE: CITIȚI CU ATENȚIE.

Numai pentru uz casnic

Instrucțiuni de utilizare:

- *Puneți scaunul stabil pe o podea plană.
- *Îndepărtați-vă de flăcările deschise.
- *Evitați supraîncărcarea la scaun.

Precauții înainte de montare:

- *Pregătiți o zonă de montare curată și uscată.
- *Verificați dacă produsul nu este deteriorat.
- *Verificați dacă nu lipsește niciuna dintre piese.

Întreținere:

- *Curățați cu o țesătură moale.
- *Verificați regulat șezutul.

Condiții de depozitare:

*Țesătura trebuie depozitată complet uscată, într-un loc curat și uscat pentru a evita riscurile de mucegai.

Atenție la pericolele de strivire și tăiere în timpul asamblării.

Producătorul își declină orice responsabilitate în cazul daunelor cauzate de o instalare greșită sau de ofilire.

Atenție! Numai personalul calificat poate înlocui sau repara componentele pentru reglarea înălțimii mobilierului de ședere cu stocare de energie.

Dacă produsul are părți electrice:

Acest aparat poate fi utilizat de copii cu vârsta începând de la 8 ani și de persoane cu capacități fizice, senzoriale sau mentale reduse sau cu lipsă de experiență și cunoștințe, dacă au fost supravegheați sau instruiți cu privire la utilizarea aparatului în condiții de siguranță și dacă înțeleg pericolele implicate.

Copiii nu trebuie să se joace cu aparatul.

Curățarea și întreținerea de către utilizator nu trebuie să fie efectuate de copii fără supraveghere.

Aparatul trebuie utilizat numai cu unitatea de alimentare furnizată împreună cu aparatul.

Cablul sau cordonul flexibil extern al acestui transformator nu poate fi înlocuit; dacă cordonul este deteriorat, transformatorul trebuie casat.

Dacă Aparatul are o suprafață încălzită. Persoanele insensibile la căldură trebuie să fie atente atunci când utilizează aparatul.

Unitatea de alimentare nu trebuie utilizată, dacă pini ai părții fișei sunt deteriorați.



Removing Wrinkles & Fluffing Cushions

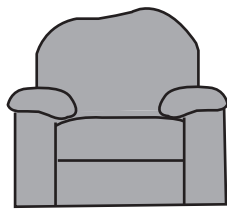
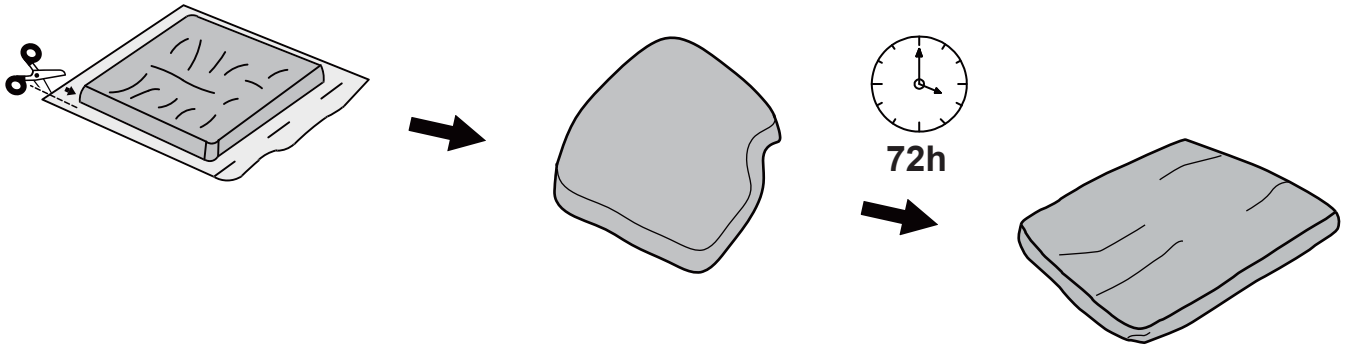

BEFORE

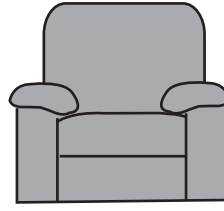
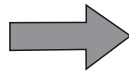

AFTER

1



2

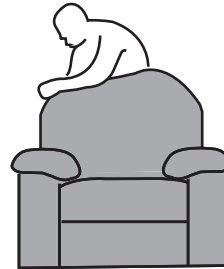

3

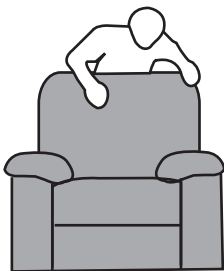

4

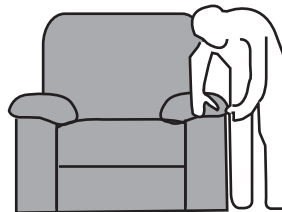

ATTENTION



EN

Wrinkles should smooth out naturally within 72 hours or can be steamed. For optimal fullness, fluff cushions regularly by hand.

FR

Les plis devraient disparaître naturellement dans les 72 heures ou peuvent être éliminés à la vapeur. Pour une plénitude optimale, gratifiez régulièrement les coussins à la main.

DE

Falten sollten sich innerhalb von 72 Stunden von selbst glätten oder können mit Dampf behandelt werden. Für optimale Fülle sollten die Polster regelmäßig von Hand aufgeschüttelt werden.

ES

Las arrugas deberían suavizarse naturalmente en 72 horas o pueden plancharse al vapor. Para una plenitud óptima, esponje los cojines regularmente con las manos.

PT

As rugas devem suavizar-se naturalmente em até 72 horas ou podem ser eliminadas a vapor. Para obter o volume ideal, almofade os enchimentos regularmente com as mãos.









IT

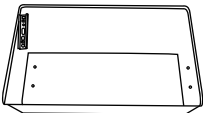
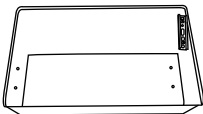

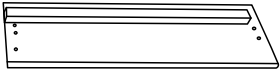

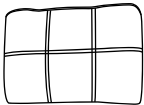
Le pieghe dovrebbero smussarsi naturalmente entro 72 ore o possono essere trattate con vapore. Per una pienezza ottimale, rassodare regolarmente i cuscini a mano.

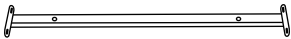
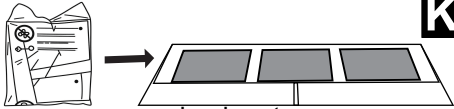
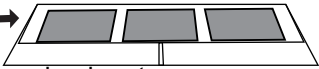
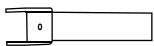

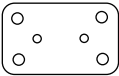
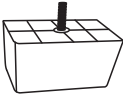

RO

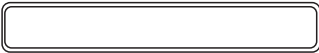
Cutele ar trebui să se netezească în mod natural în termen de 72 de ore sau pot fi tratate cu abur. Pentru o umflătură optimă, umflați pernele manual în mod regulat.

PACKING DETAILS: TOTAL 2 BOXES

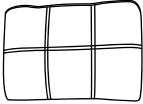
BOX 1-2		A x 1
		B x 1
		C x 1
		D x 1
		E x 1
		F x 1
		G x 2
		H x 2
		I x 2
		J x 1
	 	K x 1 backrest cover
		L x 2
		M x 2

	N x 2
	O x 2
	P x 4
	Q x 4
	U x 1
	Hardware Kit

BOX 2-2		G x 1
		R x 2
		S x 3
		T x 3

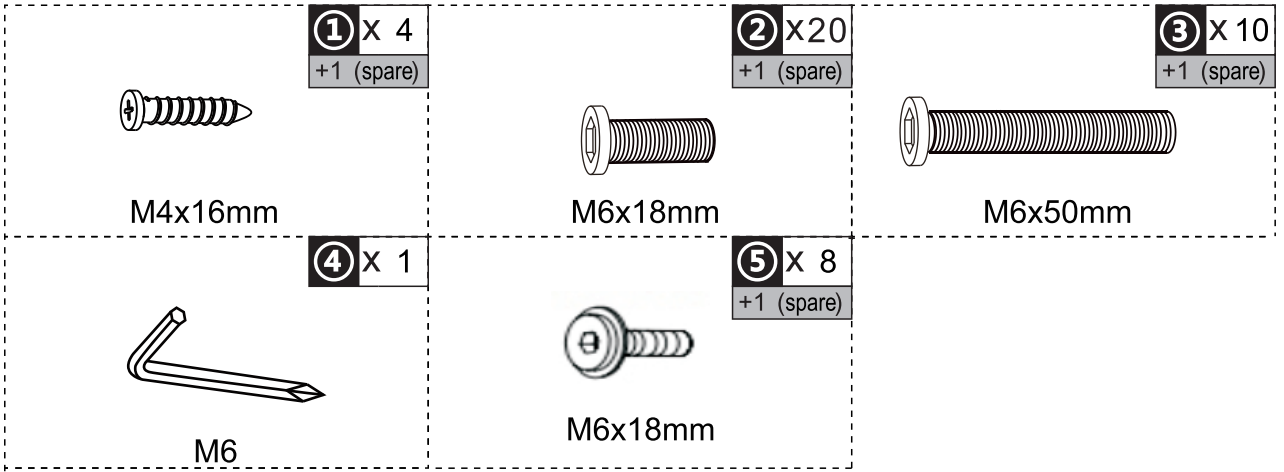

⑤ X 4

01

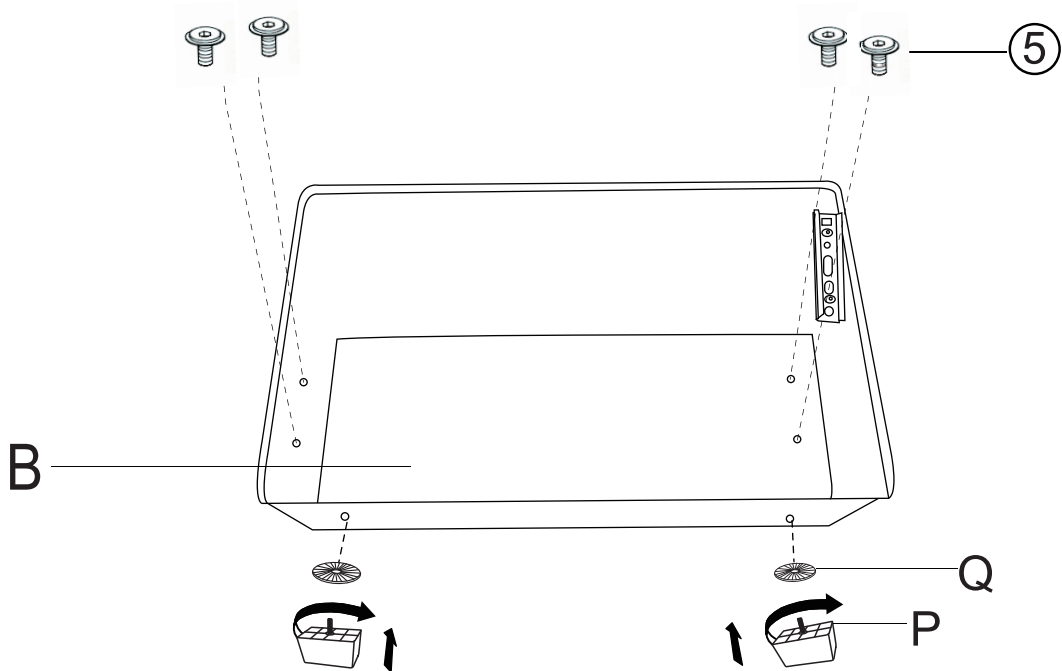

⑤ x 4

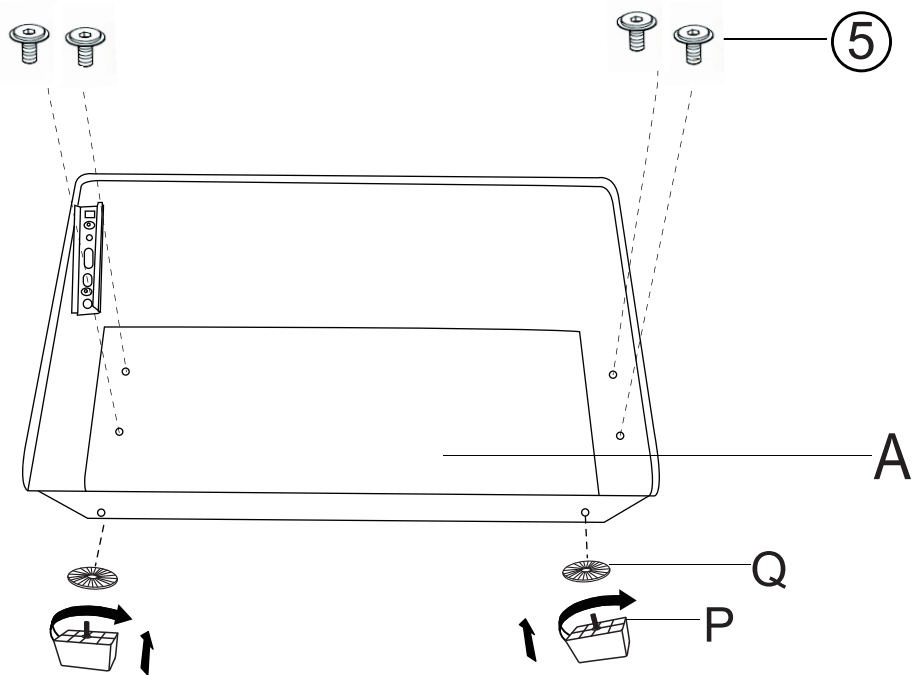

① x 2

② x 8

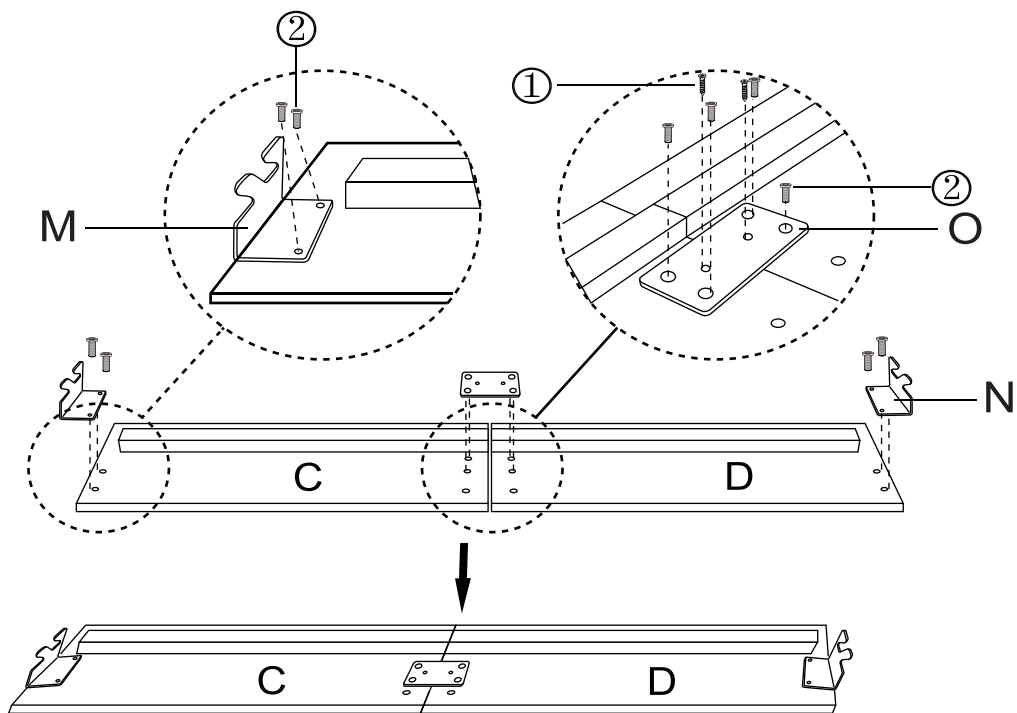

① X 2

② X 8

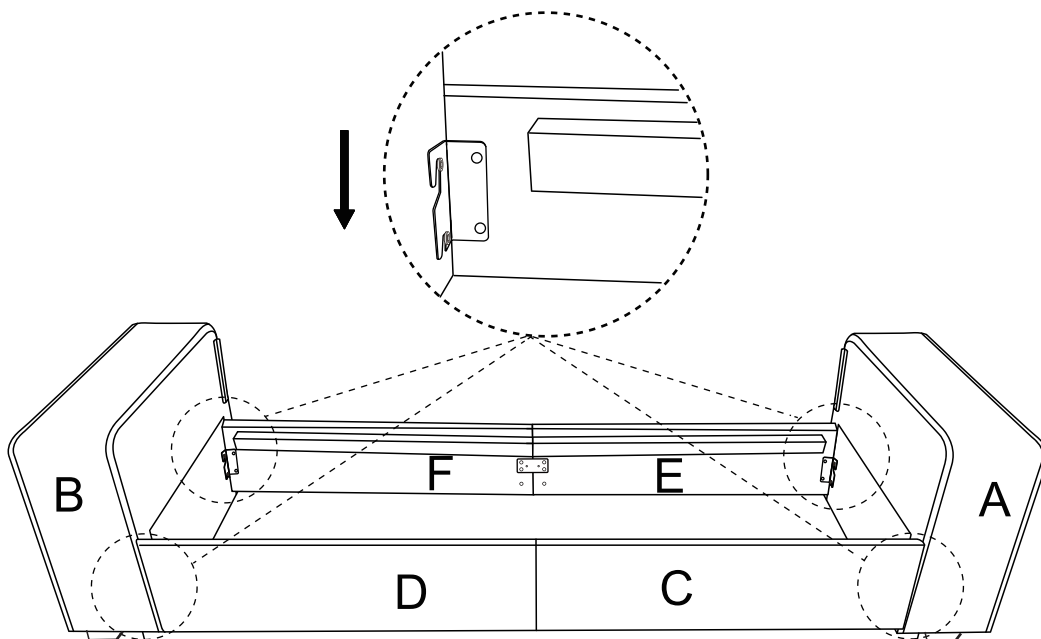
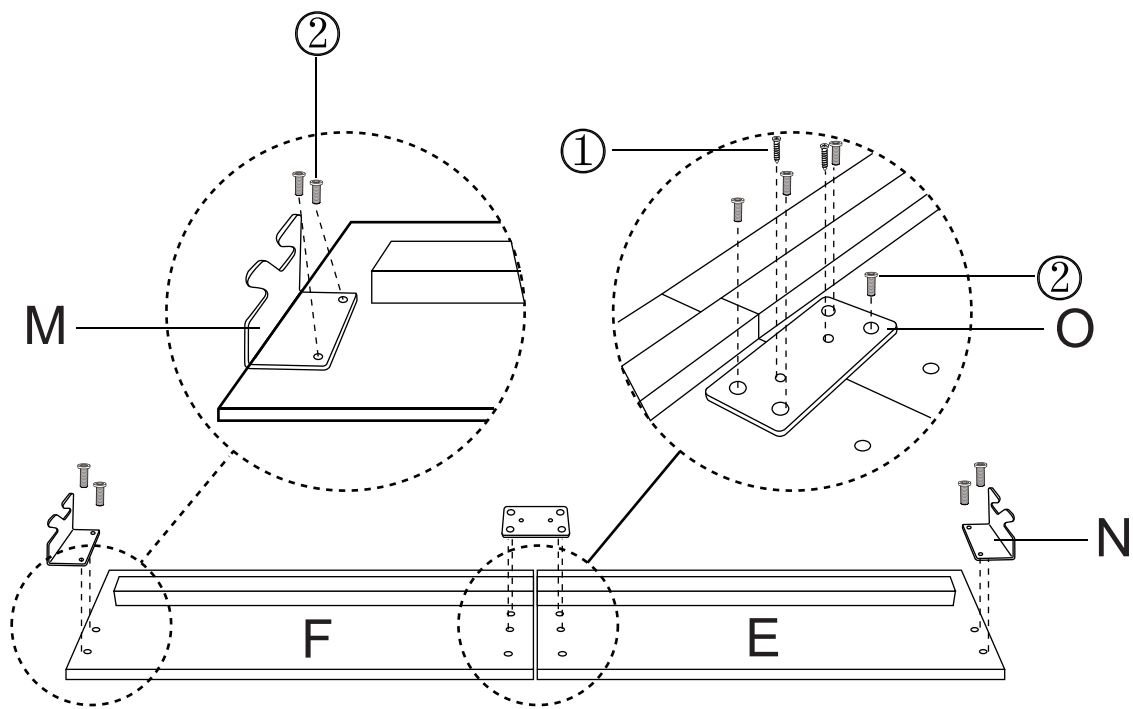

② X 4

06

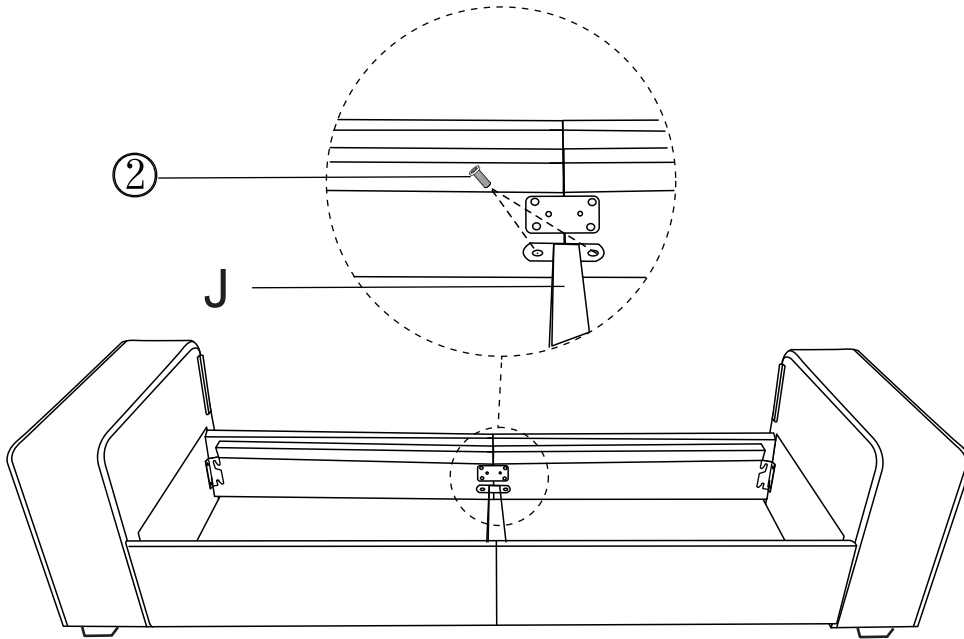

③ X 8

07

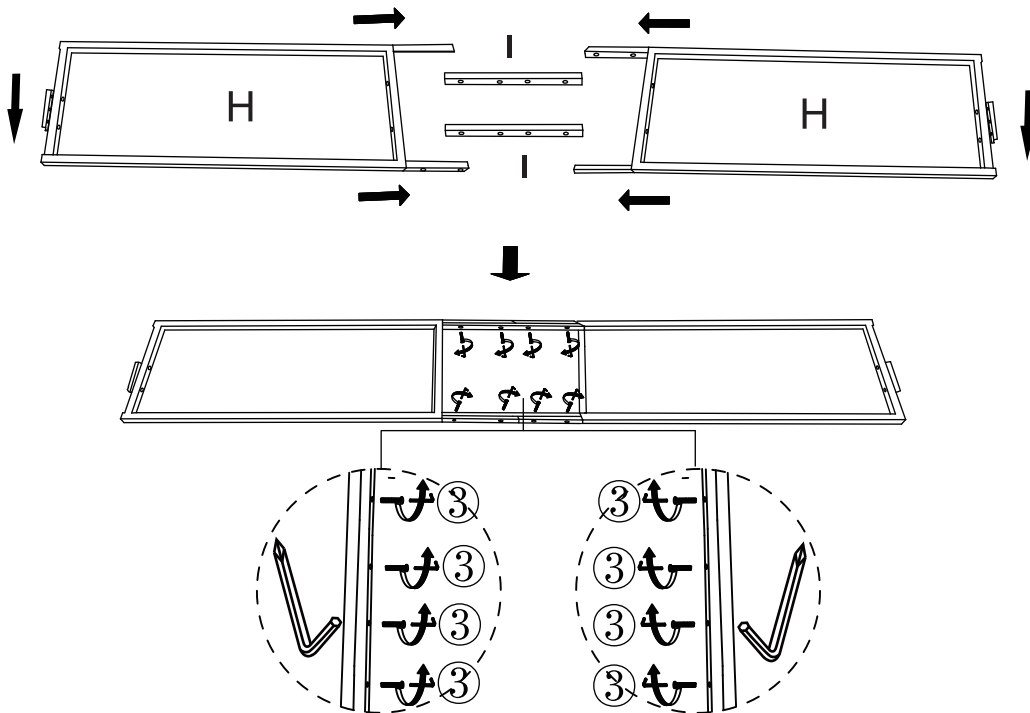

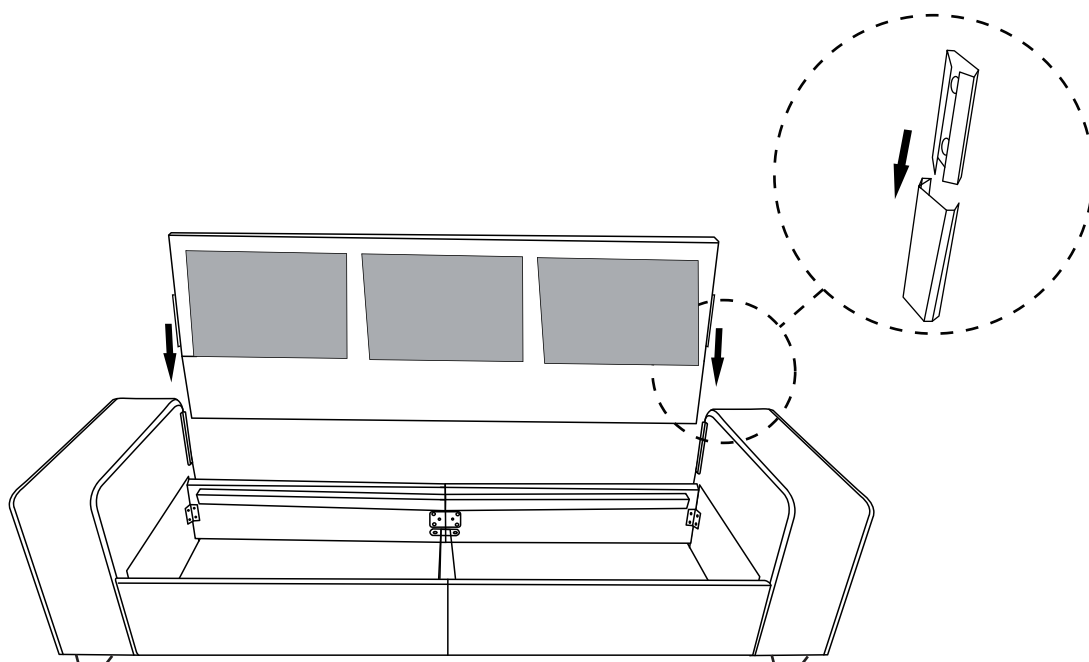
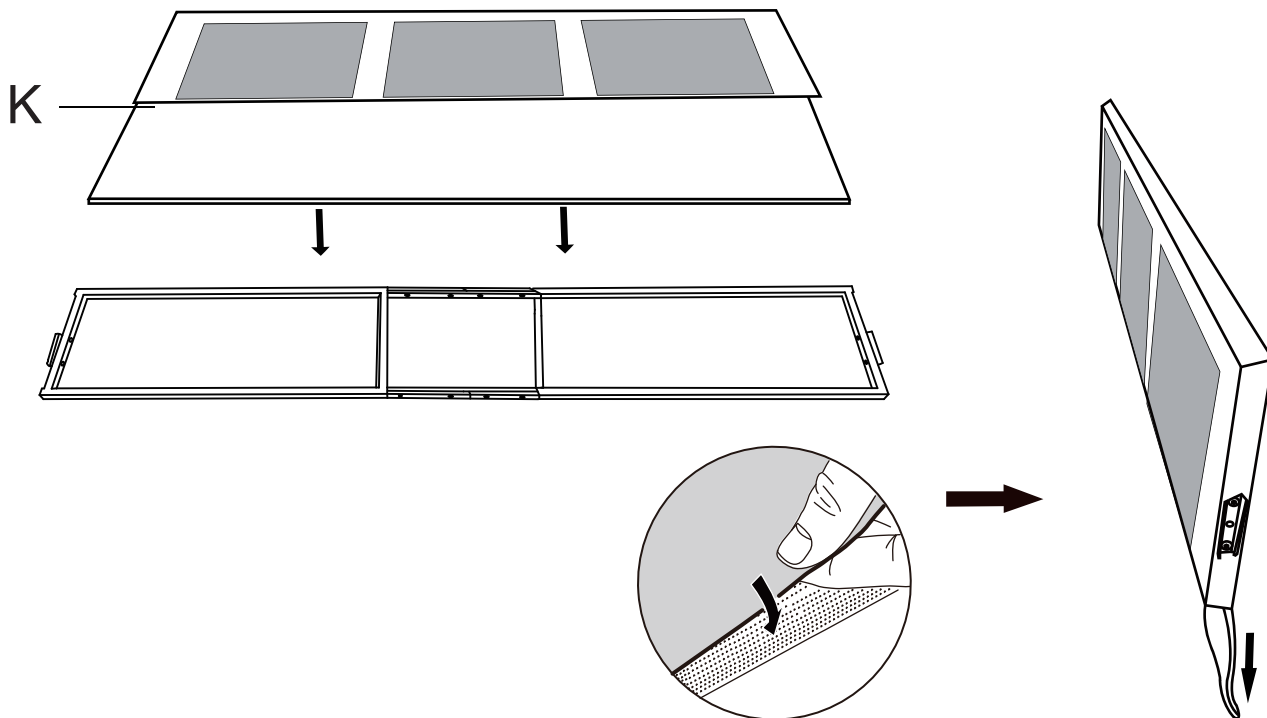

③ x 2

10

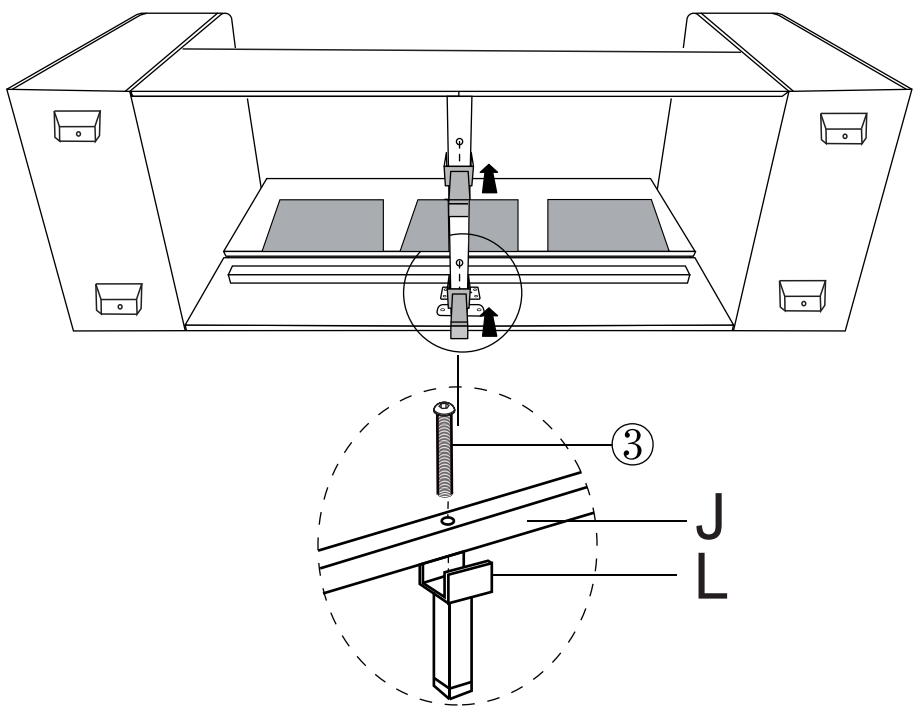

11

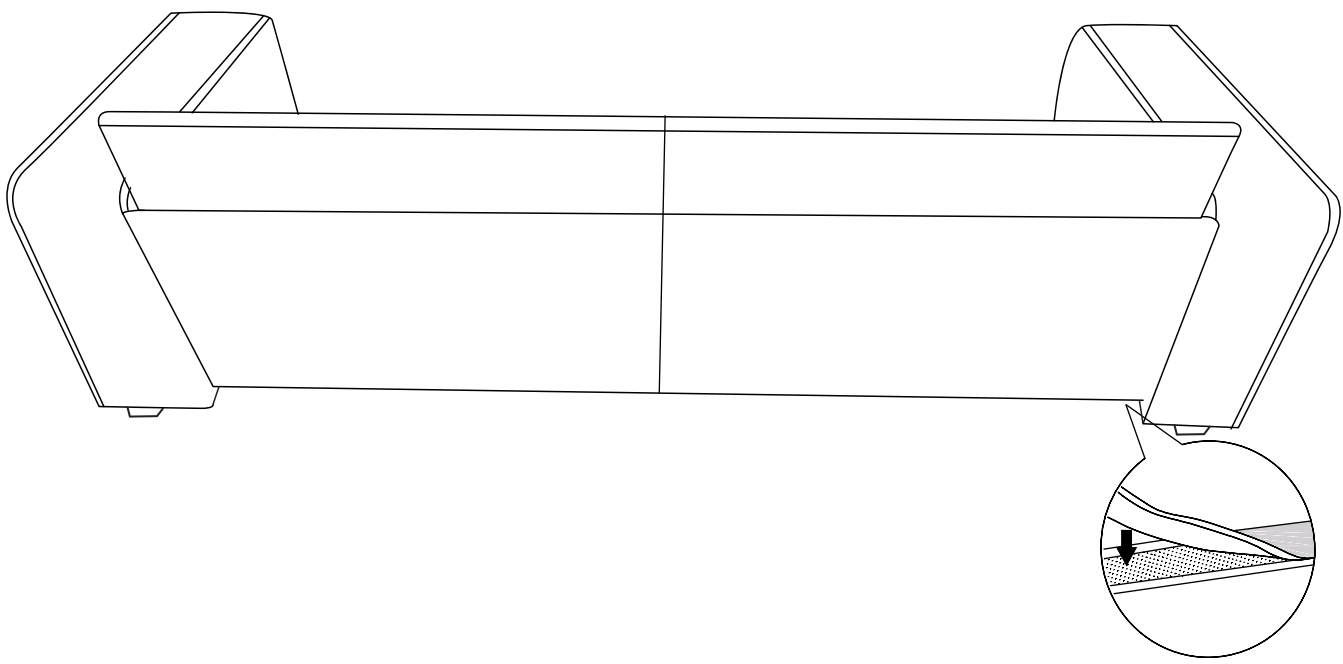

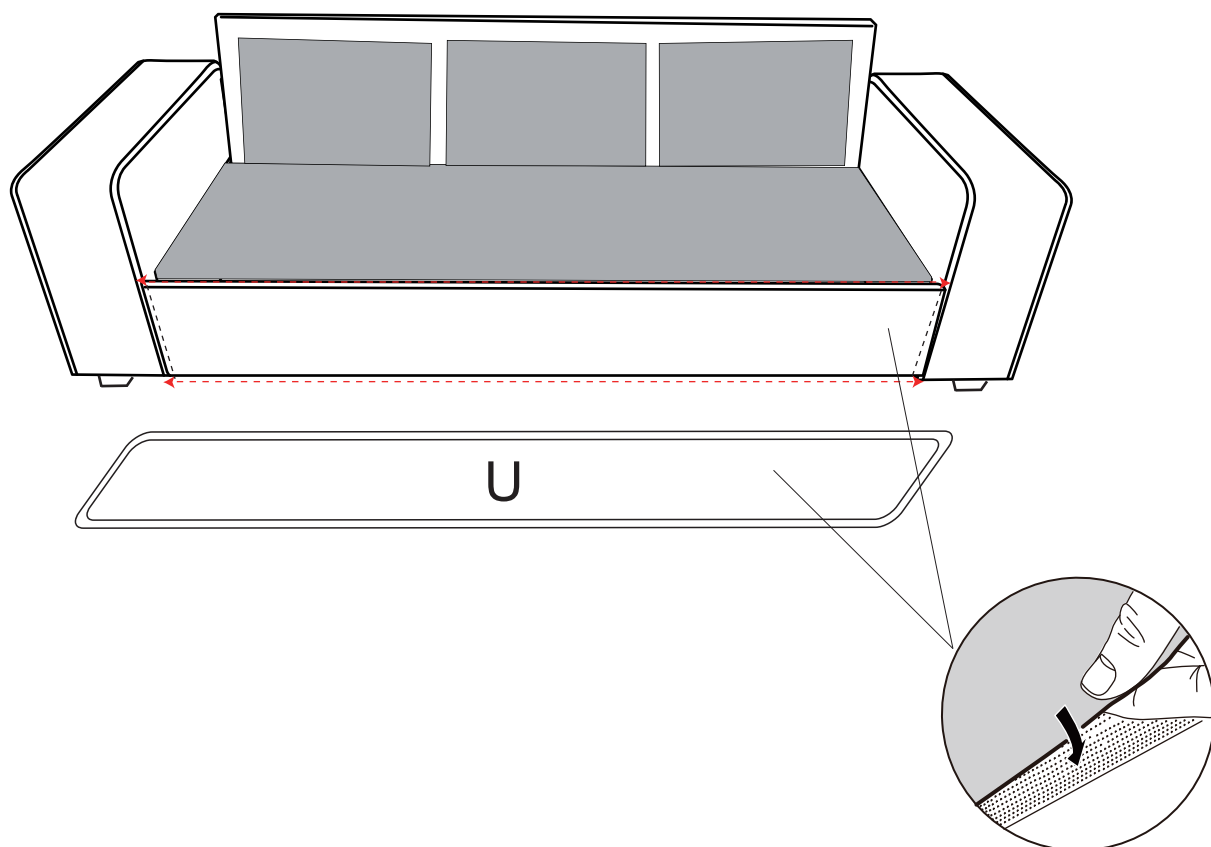
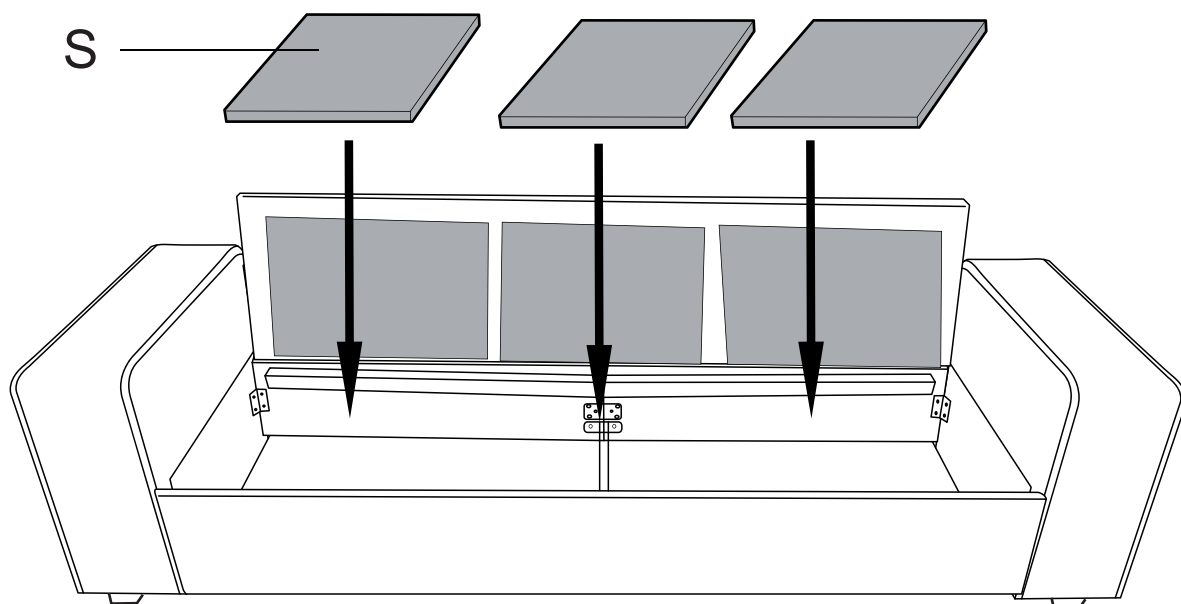

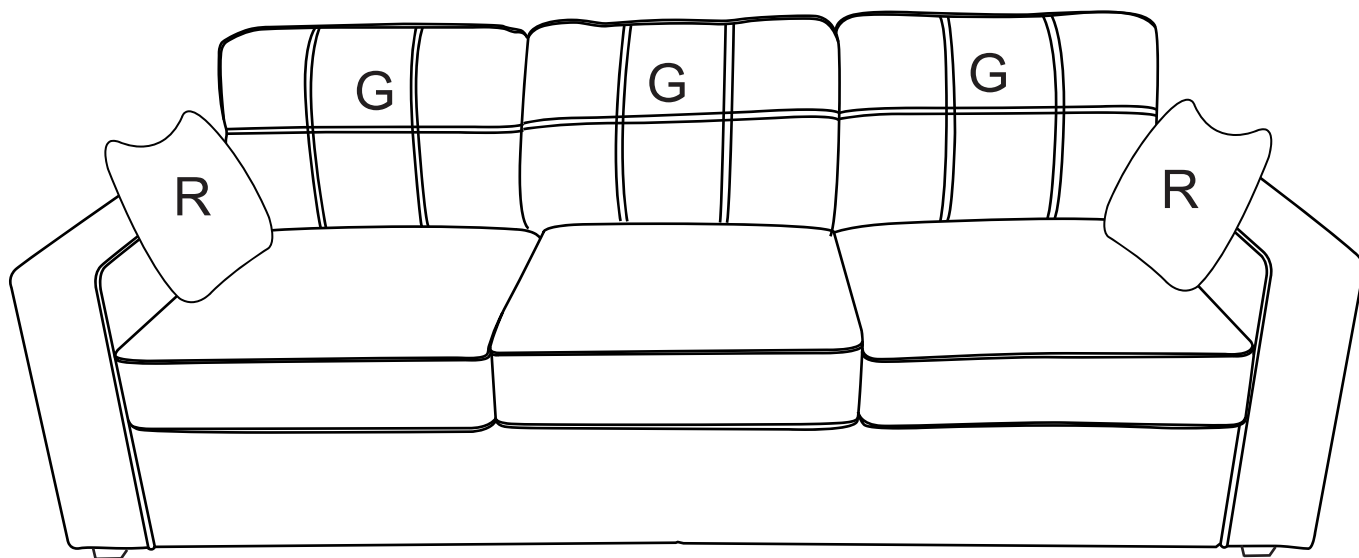
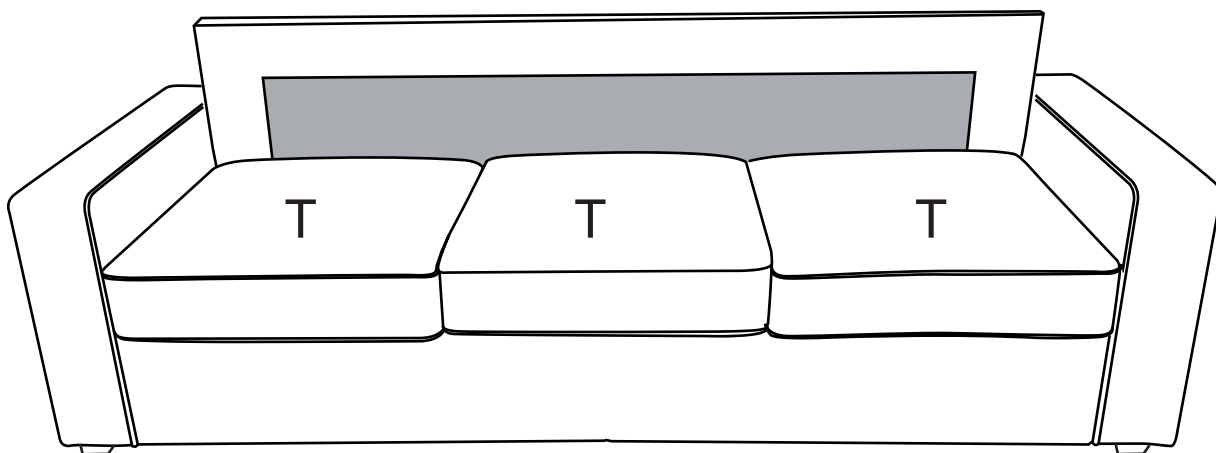

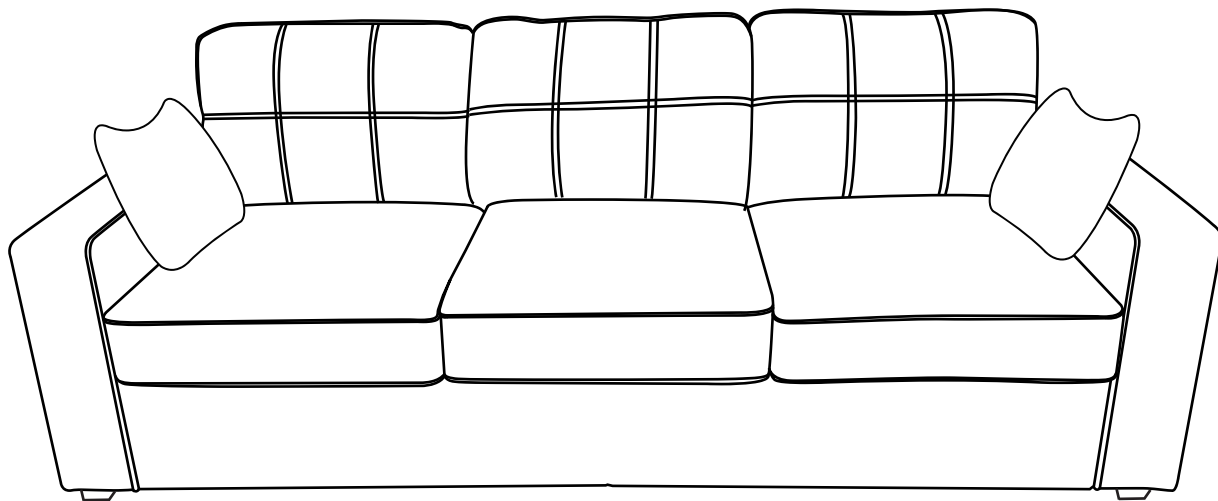



If you have any questions, please contact our customer care center, Our contact details are below:

US

 001-877-644-9366

 customerservice@aosom.com

Imported by Aosom LLC
7777 Center Ave. Suite 430
Huntington Beach, CA 92647-9998 USA
MADE IN CHINA

If you have any questions, please contact our customer care center, Our contact details are below:

UK

 0044-800-240-4004

 enquiries@mhstar.co.uk

IMPORTER ADDRESS:
MH STAR UK LTD
1 Northampton Cross Logistics Park
Northampton Cross Road
Northampton
Nn4 9FH
Tel: 0800 240 4050
enquiries@mhstar.co.uk
MADE IN CHINA

If you have any questions, please contact our customer care center, Our contact details are below:

CA

 416-792-6088

 customerservice@aosom.ca

Imported by Aosom Canada Inc.
Unit 33-1 Sparks Avenue, North York, Ontario,
Canada
M2H 2W1
MADE IN CHINA

Si vous avez la moindre question, veuillez contacter notre centre d'assistance à la clientèle, Nos coordonnées sont les suivantes:

 416-792-6088

 customerservice@aosom.ca

Importé par Aosom Canada Inc.
Unité 33-1 Sparks Avenue, North York, Ontario,
Canada M2H 2W1
Fabriqué en Chine

Wenn Sie Fragen haben, wenden Sie sich bitte an unser Kundendienstzentrum, Unsere Kontaktdaten stehen unten:

DE

 0049-0(40)-87408465

 service@aosom.de

ADRESSE DES IMPORTEURE/Hersteller/REP:
MH Handel GmbH
Wendenstraße 309
D-20537 Hamburg
Germany
IN CHINA HERGESTELLT

In caso di dubbio, si prega di contattare il nostro centro assistenza clienti, I nostri dettagli di contatto sono di seguito:

IT

 0039-0249471447

 clienti@aosom.it

IMPORTATO DA/Produttore/REP:
AOSOM Italy srl
Centro Direzionale Milanofiori
Strada 1 Palazzo F1
20057 Assago (MI)
P.I.: 08567220960
FATTO IN CINA

Si tiene alguna pregunta, comuníquese con nuestro Centro de Atención al Cliente, Nuestros datos de contacto son los siguientes:

ES

 0034-931294512

 atencioncliente@aosom.es

IMPORTADOR/Fabricante/REP:
SPANISH AOSOM, S.L.
C/ROC GROS, Nº15.08550, ELS HOSTALET DE BALENYÀ, SPAIN.
B66295775
HECHO EN CHINA

Se tiver alguma dúvida, por favor contacte o nosso Centro de Atendimento ao Cliente, Os nossos dados de contacto são os seguintes:

 0034-931294512

 info@aosom.pt.

Importator/Producător/REP:

RO

Aosom Romania SRL
Str. Barbu Mumuleanu, nr. 30-32
Bucuresti, Sector 2
Tel: +40 312294730
clienti@aosom.ro
Fabricat in China

Si vous avez la moindre question, veuillez contacter notre centre d'assistance à la clientèle, Nos coordonnées sont les suivantes:

FR

 0033-1-84166106

 aosom@mhfrance.fr

Importé par/Fabricant/REP:
MH FRANCE
2 Rue Maurice Hartmann
92130 Issy Les Moulineaux
France
FABRIQUÉ EN CHINE



FR

**DONNEZ
OU
RECYCLEZ**



ASSOCIATION

OU



LIVRAISON

OU



DÉCHÈTERIE

Adresses sur quefairedemesdechets.fr