

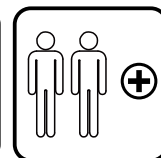
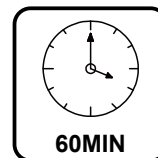
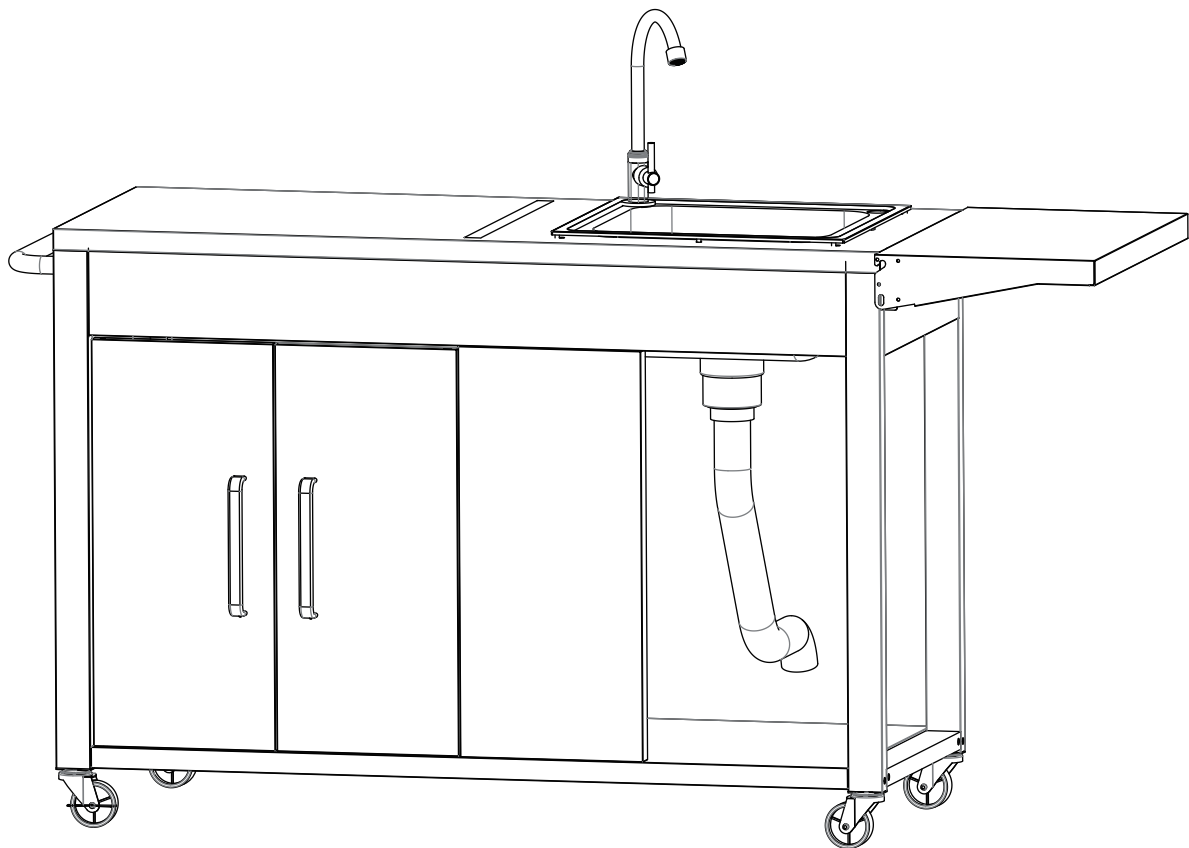

IN241200265V01

801-385V00

EN_ IMPORTANT, RETAIN FOR FUTURE REFERENCE: READ CAREFULLY.

FR_ IMPORTANT: A LIRE ATTENTIVEMENT ET À CONSERVER POUR CONSULTATION ULTÉRIEURE.

ES_ IMPORTANTE, LEA Y GUARDE PARA FUTURAS REFERENCIAS.

PT_ IMPORTANTE: LEIA ATENTAMENTE E GUARDE PARA CONSULTA FUTURA.

DE_ WICHTIG! SORGFÄLTIG LESEN UND FÜR SPÄTER NACHSCHLAGEN AUFBEWAHREN.

IT_ IMPORTANTE! CONSERVARE IL PRESENTE MANUALE PER FUTURO RIFERIMENTO E LEGGERLO ATTENTAMENTE.

RO_ IMPORTANT: CITIȚI CU ATENȚIE ȘI PĂSTRAȚI PENTRU CONSULTARE VIITOARE.

TABLE OF CONTENTS

Important Safeguards	2
Cleaning and Maintenance	2
Parts Diagram	7
Preparation	8
Hardware List	9
Parts List	10
Assembly	11-19

IMPORTANT SAFEGUARDS

When using the product, basic safety precautions should always be followed to reduce the risk of injury including the following:

Risk of injury!

Product can tip over. Do not let children climb on or play with the product.

- Keep children and pets away while assembling the product.
- Always use the product on a firm, level ground.
- Do not use this product if any parts are missing, damaged, or worn.
- To avoid scratching the floor, assemble the product on a soft surface, such as a carpet.
- Regularly examine the product for wear and tear. Stop using the product at first sign of damage or if parts become detached.
- Do not overload the product. Load the product evenly and place the heaviest items on the bottom shelf.

Cleaning and Maintenance

Cleaning

- To clean the product, wipe with a soft, slightly moist cloth.
- Never use corrosive detergents, wire brushes, abrasive scourers, metal or sharp utensils to clean the product.

Maintenance

- Regularly check that all the components and fasteners are tightened.
- Store the product in a cool and dry place away from children and pets, ideally in its original packaging.
- Avoid any vibrations and shocks.

Risk of suffocation!

- Keep any packaging materials away from children-these materials are a potential source of danger, e.g.suffocation.
- Remove all the packing materials.

Before beginning assembly, make sure all parts are present. If any parts are missing or damaged, do not attempt to assemble the products. Contact customer service for replacement parts via telephone or email.

ÍNDICE DE MATERIAS

Consideraciones de seguridad importantes	3
Limpieza y Mantenimiento	3
Diagrama de partes	7
Preparación	8
Lista de hardware	9
Lista de piezas	10
Montaje	11-19

CONSIDERACIONES DE SEGURIDAD IMPORTANTES

Al usar el producto, y para reducir el riesgo de lesiones, se deben seguir siempre las precauciones de seguridad básicas, incluidas las siguientes:

¡Riesgo de lesiones!

El producto puede volcarse. No permita que los niños trepen en o jueguen con el producto.

- Cuando arme el producto, mantenga a los niños y mascotas alejados.
- Use siempre el producto sobre un terreno firme y nivelado.
- No use el producto si alguna de las piezas está dañada, ausente o gastada.
- Para evitar raspar el piso, arme el producto sobre una superficie suave como una alfombra.
- Revise el producto regularmente y asegúrese de que no tenga desgaste ni daños. Deje de usar el producto a la primera señal de daños o si las piezas se desconectan.
- No sobrecargue el producto. Cargue el producto de manera uniforme y coloque los artículos más pesados en el estante inferior.

Limpieza y Mantenimiento

Limpieza

- Para limpiar el producto, use un paño suave y levemente humedecido.
- Jamás use detergentes corrosivos, cepillos de alambre, escobillas abrasivas, ni utensilios metálicos o afilados para limpiar el producto.

Mantenimiento

- Verifique con regularidad que todos los componentes y sujeciones estén firmes.
- Almacene el producto en un lugar fresco y seco, alejado de niños y mascotas, idealmente en su empaque original.
- Evite vibraciones y golpes.

¡Riesgo de asfixia!

- Mantenga los materiales de empaque lejos de los niños, ya que estos materiales son una posible fuente de peligro (asfixia).
- Saque todos los materiales del empaque.

Antes de comenzar el montaje, asegúrese de que todas las piezas estén presentes. Si falta alguna pieza o está dañada, no intente ensamblar los productos. Póngase en contacto con el servicio de atención al cliente para obtener piezas de repuesto por teléfono o correo electrónico.

TABLE DES MATIÈRES

Mesures de sécurité importantes 4

Nettoyage et Entretien4

Schéma des pièces 7

Instructions d'assemblage 8

Liste du matériel9

Liste des pièces10

Assemblage11-19

MESURES DE SÉCURITÉ IMPORTANTES

Lors de l'utilisation du produit, certaines mesures de sécurité élémentaires doivent toujours être respectées afin de réduire tout risque de blessures, notamment les suivantes:



Risque de blessures!

Risque de basculement du produit. Ne pas laisser des enfants escalader le produit ni jouer avec celui-ci.

- Maintenez les enfants et les animaux domestiques à l'écart lors du montage du produit.
- Utilisez toujours le produit sur un sol ferme et nivelé.
- Ne pas utiliser ce produit en cas de composants manquants, endommagés ou usés.
- Afin d'éviter des rayures sur le plancher, montez le produit sur une surface molle telle qu'un tapis.
- Procédez régulièrement à un examen du produit afin de déceler toute usure éventuelle. Arrêtez d'utiliser le produit dès les premiers signes d'endommagement ou si des pièces s'en détachent.
- Ne surchargez pas le produit. Chargez le produit uniformément et placez les articles les plus lourds sur l'étagère du bas.

Nettoyage et Entretien

Nettoyage

- Pour nettoyer le produit, essuyez-le à l'aide d'un chiffon doux légèrement humide.
- Ne jamais utiliser de détergents corrosifs, de brosses métalliques, de tampons à récurer abrasifs, d'ustensiles métalliques ou coupants pour nettoyer le produit.

Entretien

- Assurez-vous régulièrement que tous les composants et toutes les fixations sont solidement fixés.
- Rangez le produit dans un endroit frais et sec hors de portée des enfants et des animaux familiers, idéalement dans son emballage d'origine.
- Évitez toutes vibrations et tous chocs.



Risque d'étouffement!

- Conservez tous les matériaux d'emballage hors de la portée des enfants: ces matériaux constituent une source de danger potentiel, p.ex. étouffement.
- Retirez-en tous les matériaux d'emballage.

Avant de commencer l'assemblage, assurez-vous que toutes les pièces sont présentes. Si des pièces sont manquantes ou endommagées, n'essayez pas d'assembler les produits. Contactez le service de clientèle pour les pièces de rechange par téléphone ou par e-mail.

INHALTSVERZEICHNIS

Wichtige sicherheitsvorkehrungen	5
Reinigung und Wartung	5
Teile-Diagramm	7
Vorbereitung	8
Zubehör-Liste	9
Teileliste	10
Montage	11-19

Reinigung und Wartung

Reinigung

- Wischen Sie das Produkt mit einem weichen, leicht angefeuchteten Tuch ab, um es zu reinigen.
- Verwenden Sie niemals ätzende Reinigungsmittel, Drahtbürsten, Scheuerschwämme, Metall oder scharfe Gegenstände zur Reinigung des Produkts.

Wartung

- Prüfen Sie regelmäßig, ob alle Bauteile und Verschlüsse festgezogen sind.
- Bewahren Sie das Produkt an einem kühlen und trockenen Ort, am besten in der Originalverpackung, auf.
- Vermeiden Sie Erschütterungen und Stöße.

WICHTIGE SICHERHEITSVORKEHRUNGEN

Bei der Verwendung des Produkts sollten immer grundlegende Sicherheitsvorkehrungen getroffen werden, um das Verletzungsrisiko zu verringern, einschließlich der folgenden:



Es besteht Verletzungsgefahr!

Das Produkt kann umkippen. Lassen Sie Kinder nicht auf das Gerät klettern oder damit zu spielen.

- Halten Sie Kinder und Haustiere fern, während Sie das Produkt zusammenbauen.
- Die Verwendung des Produkts sollte immer auf einem festen, ebenen Untergrund erfolgen.
- Die Verwendung dieses Produkts ist nicht erlaubt, wenn Teile fehlen, beschädigt oder abgenutzt sind.
- Um Kratzer auf dem Boden zu vermeiden, stellen Sie das Produkt auf einer weichen Oberfläche, wie z.B. einem Teppich, auf.
- Untersuchen Sie das Produkt regelmäßig auf Abnutzung und Verschleiß. Die Verwendung des Produkts sollte bei den ersten Anzeichen einer Beschädigung oder beim Lösen von Teilen eingestellt werden.
- Überladen Sie das Produkt nicht. Beladen Sie das Produkt gleichmäßig und stellen Sie die schwersten Gegenstände auf die unterste Ablage.



Es besteht Erstickengefahr!

- Halten Sie alle Verpackungsmaterialien von Kindern fern - diese Materialien stellen eine potenzielle Gefahrenquelle dar, z.B. Erstickengefahr.
- Entfernen Sie das gesamte Verpackungsmaterial.

Bevor Sie mit dem Zusammenbau beginnen, stellen Sie sicher, dass alle Teile vorhanden sind. Wenn Teile fehlen oder beschädigt sind, versuchen Sie nicht, die Produkte zusammenzubauen. Wenden Sie sich für Ersatzteile telefonisch oder per E-Mail an den Kundendienst.

INDICE DEI CONTENUTI

Precauzioni importanti	6
Pulizia e Manutenzione	6
Schema delle Parti	7
Preparazione	8
Elenco della minuteria	9
Lista Parti	10
Assemblaggio	11-19

Pulizia e Manutenzione

Pulizia

- Per pulire il prodotto, passare un panno morbido e leggermente umido.
- Per pulire il prodotto, non utilizzare mai detersivi corrosivi, spazzole metalliche, pagliette abrasive, utensili metallici o taglienti.

Manutenzione

- Controllare regolarmente che tutti i componenti e i dispositivi di fissaggio siano stretti saldamente.
- Conservare il prodotto in un luogo fresco e asciutto, lontano dalla portata di bambini e animali domestici, preferibilmente nella sua confezione originale.
- Evitare vibrazioni e urti.

IMPORTANTI PRECAUZIONI

Quando si utilizza il prodotto, è necessario seguire sempre le precauzioni di sicurezza basilari per ridurre il rischio di lesioni personali, tra cui:



Rischio di infortunio!

Il prodotto può ribaltarsi. Non lasciare che i bambini si arrampichino o giochino con il prodotto.

- Tenere a distanza bambini e animali domestici durante l'assemblaggio del prodotto.
- Utilizzare sempre il prodotto su un terreno solido e in piano.
- Non utilizzare questo prodotto se mancano alcune delle parti, o se sono danneggiate o usurate.
- Per evitare di graffiare il pavimento, assemblare il prodotto su una superficie morbida, come un tappeto.
- Esaminare regolarmente il prodotto per verificare la presenza di eventuali segni di usura. Smettere di utilizzare il prodotto al primo segno di danni o se alcune delle parti si staccano.
- Non sovraccaricare il prodotto. Caricare il prodotto in modo uniforme e posizionare gli oggetti più pesanti sul ripiano inferiore.



Pericolo di soffocamento!

- Tenere i materiali di imballaggio fuori dalla portata dei bambini: questi materiali rappresentano una potenziale fonte di pericolo, come il pericolo di soffocamento.
- Rimuovere tutti i materiali di imballaggio.

Prima di iniziare con l'assemblaggio, assicurarsi che tutte le parti siano presenti. Se vi sono parti mancanti o danneggiate, non tentare di assemblare il prodotto. Contattare il servizio clienti tramite telefono o e-mail per ottenere le parti di ricambio.

ÍNDICE

Precauções importantes -----	2
Limpeza e manutenção – -----	2
Diagrama de peças – -----	7
Preparação – -----	8
Lista de ferragens – -----	9
Lista de peças -----	10
Montagem -----	11-19

MEDIDAS DE SEGURANÇA IMPORTANTES

Ao utilizar o produto, devem ser sempre seguidas as precauções básicas de segurança para reduzir o risco de lesões, incluindo as seguintes:

**Risco de ferimentos!**

O produto pode tombar. Não deixe as crianças subirem para cima do produto nem brincarem com ele.

- Mantenha as crianças e os animais de estimação afastados durante a montagem do produto.
- Utilize sempre o produto sobre uma superfície firme e nivelada.
- Não utilize este produto se alguma peça estiver em falta, danificada ou desgastada.
- Para evitar riscar o chão, monte o produto sobre uma superfície macia, como um tapete.
- Inspeccione regularmente o produto para verificar se há sinais de desgaste. Deixar de utilizar o produto ao primeiro sinal de danos ou se alguma peça se soltar.
- Não sobrecarregue o produto. Distribua o peso uniformemente e coloque os itens mais pesados na prateleira inferior.

Limpeza e manutenção

Limpeza

- Para limpar o produto, passe um pano macio e ligeiramente húmido.
- Nunca utilize detergentes corrosivos, escovas de arame, esponjas abrasivas, utensílios de metal ou afiados para limpar o produto.

Manutenção

- Verifique regularmente se todos os componentes e fixações estão bem apertados.
- Guarde o produto num local fresco e seco, fora do alcance de crianças e animais de estimação, de preferência na embalagem original.
- Evite vibrações e choques.

**Risco de asfixia!**

Mantenha todos os materiais de embalagem fora do alcance das crianças — estes materiais constituem uma fonte potencial de perigo, por exemplo, de asfixia.
Retire todos os materiais de embalagem.

Antes de iniciar a montagem, certifique-se de que todas as peças estão presentes. Se faltar alguma peça ou se alguma estiver danificada, não tente montar os produtos. Contacte o serviço de apoio ao cliente por telefone ou e-mail para solicitar peças de substituição.

CUPRINS

Măsuri de siguranță importante-2

Curățare și întreținere-2

Schema componentelor-7

Pregătire-8

Lista componentelor hardware-9

Lista pieselor-10

Asamblare-11-19

MĂSURI DE SIGURANȚĂ IMPORTANTE

Atunci când utilizați produsul, trebuie respectate întotdeauna măsurile de siguranță de bază pentru a reduce riscul de accidentare, printre care se numără următoarele:

**Pericol de rănire!**

Produsul se poate răsturna. Nu lăsați copiii să se urce pe produs sau să se joace cu el.

- Țineți copiii și animalele de companie la distanță în timpul asamblării produsului.
- Utilizați întotdeauna produsul pe o suprafață stabilă și plană.
- Nu utilizați acest produs dacă lipsesc piese, dacă sunt deteriorate sau uzate.
- Pentru a evita zgârierea podelei, asamblați produsul pe o suprafață moale, cum ar fi un covor.
- Verificați periodic produsul pentru a depista semne de uzură. Încetați utilizarea produsului la primul semn de deteriorare sau dacă piesele se desprind.
- Nu supraîncărcați produsul. Încărcați produsul uniform și așezați obiectele cele mai grele pe raftul de jos.

Curățare și întreținere**Curățare**

- Pentru a curăța produsul, ștergeți-l cu o cârpă moale, ușor umezită.
- Nu folosiți niciodată detergenți corozivi, perii de sârmă, bureți abrazivi, ustensile metalice sau ascuțite pentru a curăța produsul.

Întreținere

- Verificați periodic dacă toate componentele și elementele de fixare sunt strânse.
- Depozitați produsul într-un loc răcoros și uscat, departe de copii și animale de companie, de preferință în ambalajul original.
- Evitați vibrațiile și șocurile.

**Pericol de sufocare!**

Țineți toate materialele de ambalare departe de copii – acestea pot reprezenta un pericol, de exemplu de sufocare. Îndepărtați toate materialele de ambalare.

Înainte de a începe asamblarea, asigurați-vă că toate piesele sunt prezente. Dacă lipsesc sau sunt deteriorate anumite piese, nu încercați să asamblați produsele. Contactați serviciul clienți pentru a solicita piese de schimb, prin telefon sau e-mail.

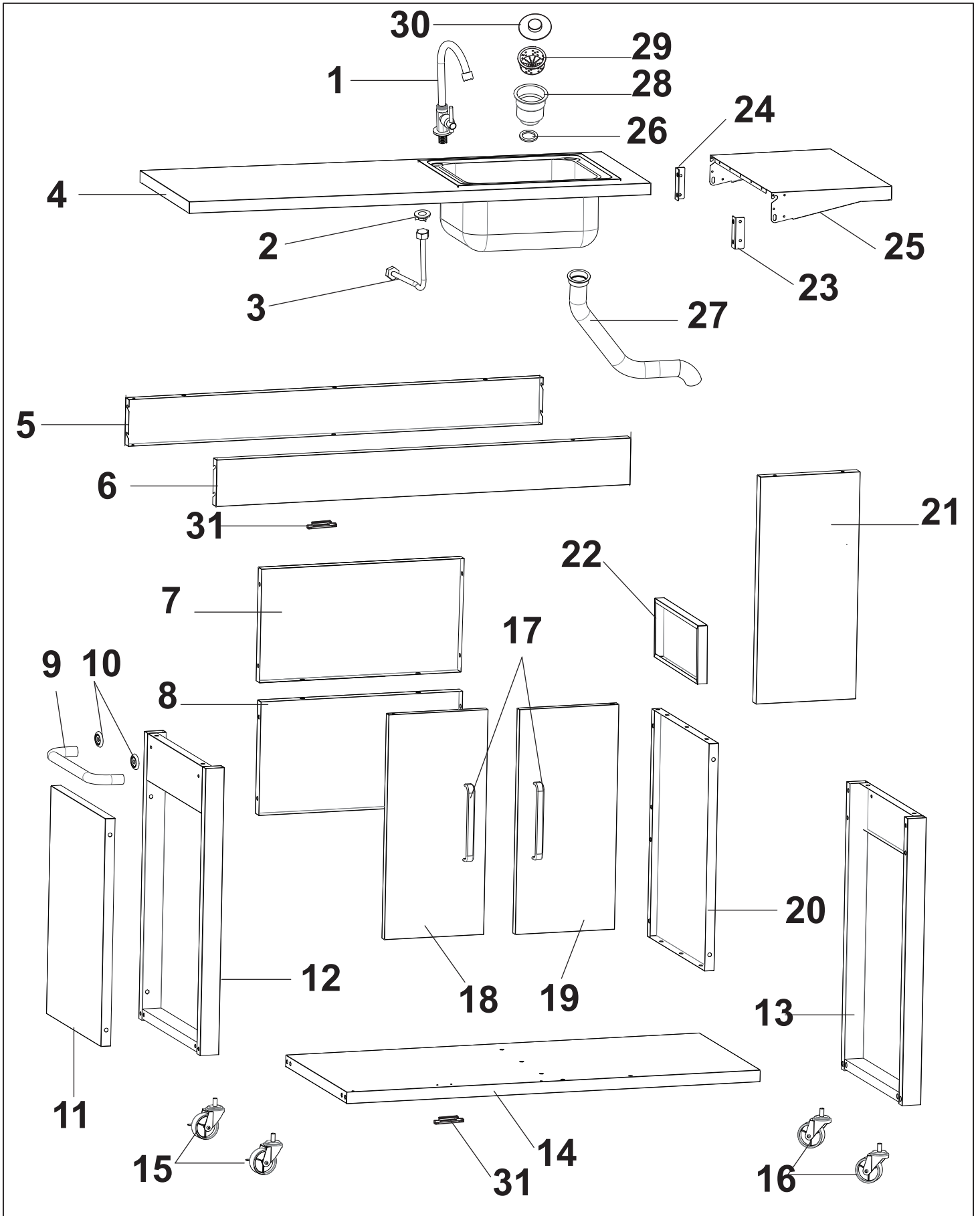



TOOLS REQUIRED

Description

Phillips screwdriver

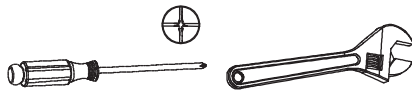

Wrench

- Tools needed: Phillips screwdriver and wrench (not included)
- Approximate assembly time: 60minutes

Notice:

1. Follow the installation instructions. Please confirm all accessories are present before installation.
2. Do not fully tighten the screws during initial assembly. Fully tighten screws only once all pieces which are correctly assembled.
3. If you encounter any problems during installation, contact our customer service.



HERRAMIENTAS REQUERIDAS

Descripción

Destornillador phillips

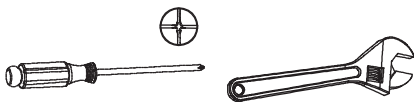

Llave

- Herramienta necesaria: Destornillador phillips y llave (no incluido)
- Tiempo aproximado de ensamblaje: 60minutos

Aviso:

1. Siga las instrucciones de instalación. Confirme que todos los accesorios estén presentes antes de la instalación.
2. No apriete completamente los tornillos durante el ensamblaje inicial. Apriete completamente los tornillos solo una vez que todas las piezas estén correctamente ensambladas.
3. Si encuentra algún problema durante la instalación, comuníquese con nuestro servicio al cliente.



OUTILS REQUIS

Description

Tournevis phillips

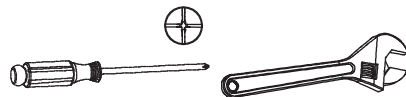

Clé

- Outils nécessaires: Tournevis phillips et clé (non inclus)
- Temps nécessaire pour l' assemblage: 60minutes

Remarquer:

1. Suivez les instructions d'installation. Veuillez confirmer que tous les accessoires sont présents avant l'installation.
2. Ne serrez pas complètement les vis lors de l'assemblage initial. Ne serrez complètement les vis qu'une fois toutes les pièces correctement assemblées.
3. Si vous rencontrez des problèmes lors de l'installation, contactez notre service client.



UNELTE NECESARE

Descrição

Chave de fendas Phillips

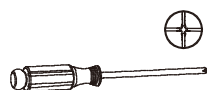

Chave inglesa



- Ferramentas necessárias: chave de fendas Phillips e chave inglesa (não incluídas)
- Tempo aproximado de montagem: 60 minutos

Aviso:

1. Siga as instruções de instalação. Certifique-se de que todos os acessórios estão presentes antes da instalação.
2. Não aperte totalmente os parafusos durante a montagem inicial. Aperte-os totalmente apenas depois de todas as peças estarem corretamente montadas.
3. Se tiver algum problema durante a instalação, contacte o nosso serviço de apoio ao cliente.



DE

ERFORDERLICHES WERKZEUG

Beschreibung

Kreuzschlitzschraubendreher

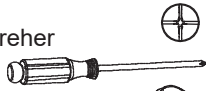

Schraubenschlüssel



- **Benötigtes Werkzeug:** Kreuzschlitzschraubendreher und Schraubenschlüssel (nicht enthalten)
- **Ungefähre Montagezeit:** 60 Minuten

Hinweis:

1. Bitte befolgen Sie die Aufstellungsanleitung und vergewissern Sie sich, dass alle Zubehörteile vorhanden sind, bevor Sie die Aufstellung vornehmen.
2. Ziehen Sie die Schrauben bei der Vormontage nicht vollständig fest. Ziehen Sie die Schrauben erst dann vollständig fest, wenn alle Teile korrekt montiert sind.
3. Sollten bei der Aufstellung Probleme auftreten, wenden Sie sich bitte an unseren Kundendienst.



IT

UTENSILI NECESSARI

Descrizione

Cacciavite Phillips

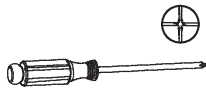

Chiave inglese



- Utensili necessari: cacciavite Phillips e chiave inglese (non inclusi)

- Tempo di assemblaggio approssimativo: 60 minuti

Avviso:

1. Seguire le istruzioni di installazione. Prima del montaggio, verificare che tutti gli accessori siano presenti.
2. Non stringere completamente le viti durante la fase iniziale di montaggio. Stringere completamente le viti solo dopo aver assemblato correttamente tutti i componenti.
3. In caso di problemi durante l'installazione, contattare il nostro servizio assistenza clienti.



RO

UNELTE NECESARE

Descriere

șurubelniță Phillips

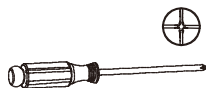

Cheie









- Unelte necesare: șurubelniță cruciformă și cheie (nu sunt incluse)
- Durata aproximativă de asamblare: 60 de minute



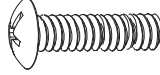

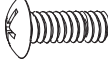





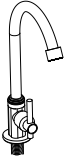

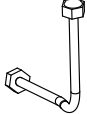
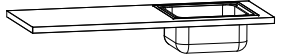

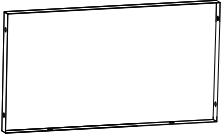



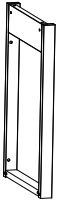

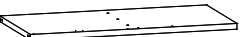
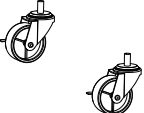
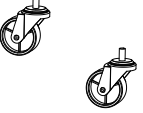

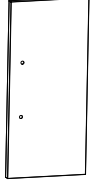
Atenție:

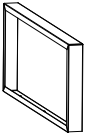
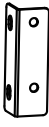
1. Respectați instrucțiunile de instalare. Vă rugăm să verificați dacă toate accesoriile sunt prezente înainte de instalare.
2. Nu strângeți complet șuruburile în timpul asamblării inițiale. Strângeți complet șuruburile numai după ce toate piesele au fost asamblate corect.
3. Dacă întâmpinați probleme în timpul instalării, contactați serviciul nostru de relații cu clienții.

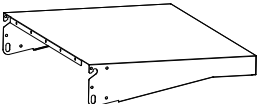
Hardware List

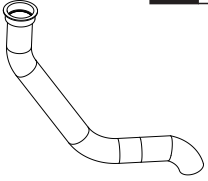
<p>A x47 +1(spare)</p>  <p>M6*12</p>	<p>B x4 +1(spare)</p>  <p>M6*19</p>	<p>C x8 +1(spare)</p>  <p>M6*70</p>	<p>D x4 +1(spare)</p>  <p>M6</p>
<p>E x4 +1(spare)</p>  <p>M4*6</p>	<p>F x2</p>  <p>M6*16</p>	<p>G x4 +1(spare)</p>  <p>M3*10</p>	<p>H x4 +1(spare)</p>  <p>M3</p>

Parts List

 <p>1 x 1</p>	 <p>2 x 1</p>	 <p>3 x 1</p>	 <p>4 x 1</p>
 <p>5 x 1</p>	 <p>6 x 1</p>	 <p>7 x 1</p>	 <p>8 x 1</p>
 <p>9 x 1</p>	 <p>10 x 2</p>	 <p>11 x 1</p>	 <p>12 x 1</p>
 <p>13 x 1</p>	 <p>14 x 1</p>	 <p>15 x 2</p>	 <p>16 x 2</p>
 <p>17 x 2</p>	 <p>18 x 1</p>	 <p>19 x 1</p>	 <p>20 x 1</p>
 <p>21 x 1</p>	 <p>22 x 1</p>	 <p>23 x 1</p>	 <p>24 x 1</p>
 <p>25 x 1</p>	 <p>26 x 1</p>	 <p>27 x 1</p>	 <p>28 x 1</p>
 <p>29 x 1</p>	 <p>30 x 1</p>	 <p>31 x 2</p>	

A x4

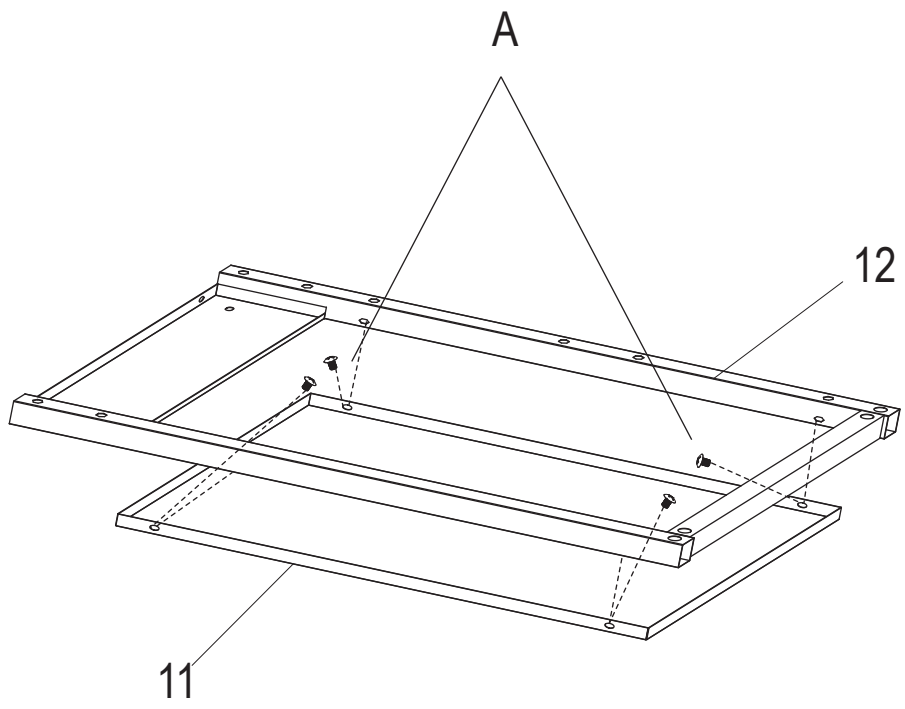

C x8

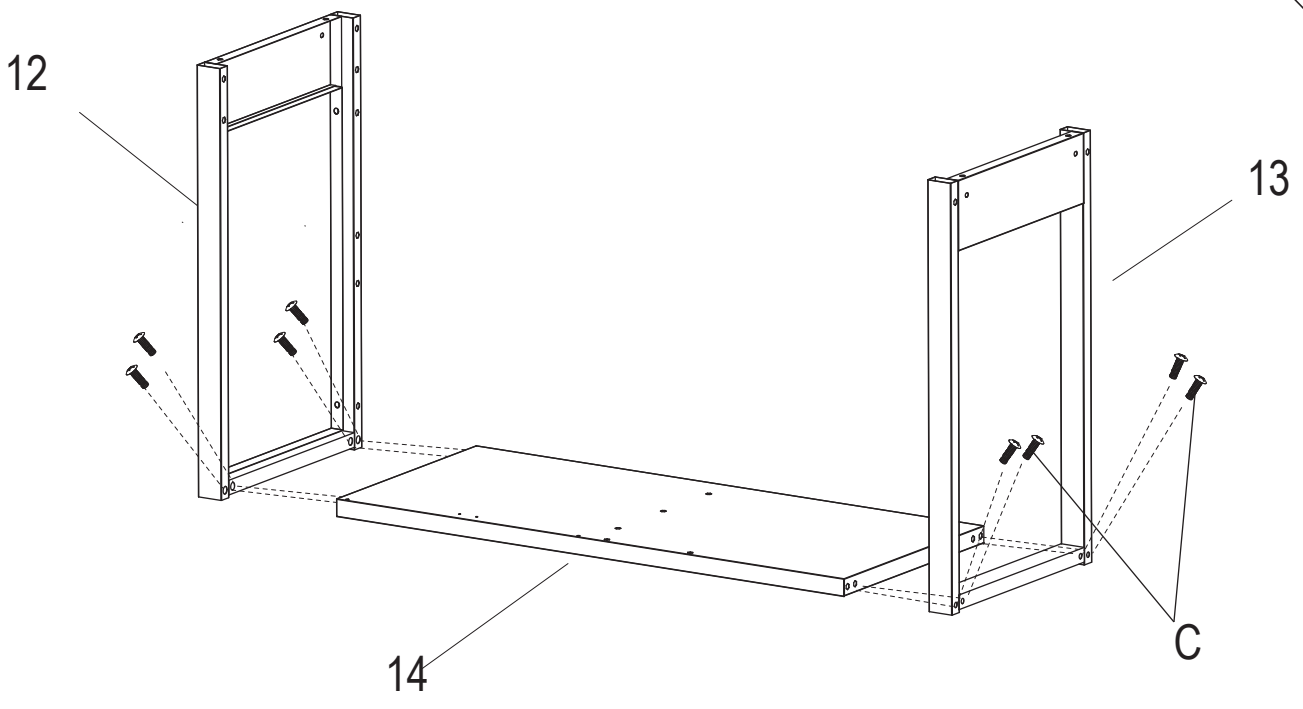

EN_ Flat surface of Part 20 faces Part 13.

Note relative positions of circled holes.

FR_ La face plane de la pièce n° 20 est orientée vers la pièce n° 13.

Notez la position relative des trous entourés.

ES_ La superficie plana de la pieza 20 queda frente a la pieza 13.

Obsérvese la posición relativa de los orificios marcados con un círculo.

PT_ A superfície plana da peça 20 está voltada para a peça 13.

Observe as posições relativas dos orifícios assinalados com um círculo.

DE_ Die ebene Fläche von Teil 20 liegt an Teil 13 an.

Beachten Sie die relative Position der eingekreisten Löcher.

IT_ La superficie piana della parte 20 è rivolta verso la parte 13.

Notare la posizione relativa dei fori cerchiati.

RO_ Suprafața plană a piesei 20 este orientată spre piesa 13.

Observați pozițiile relative ale orificiilor încercuite.

A x3

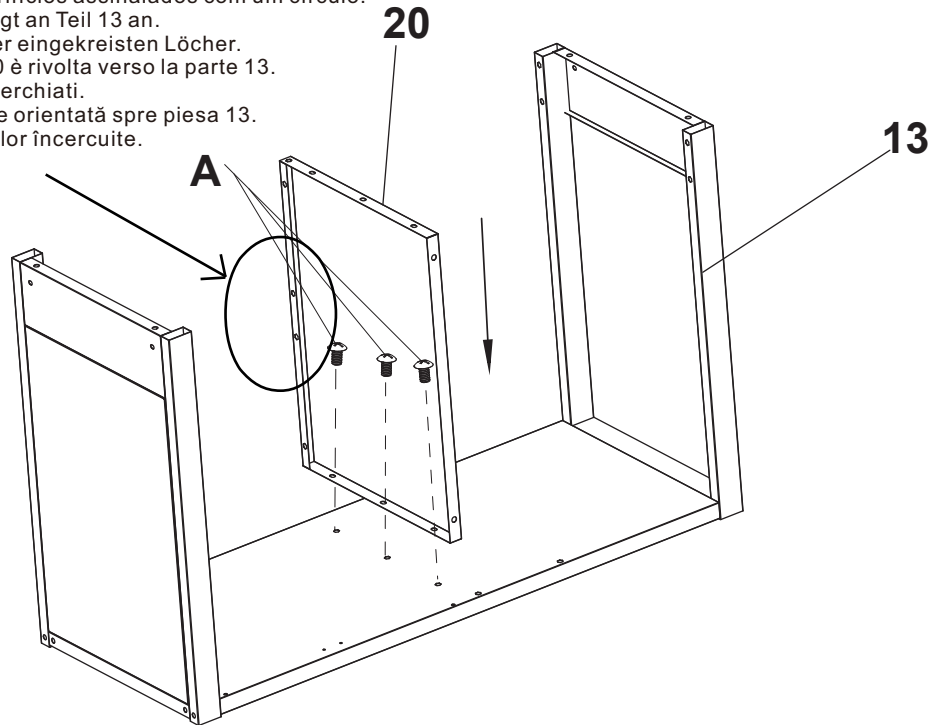

A x10

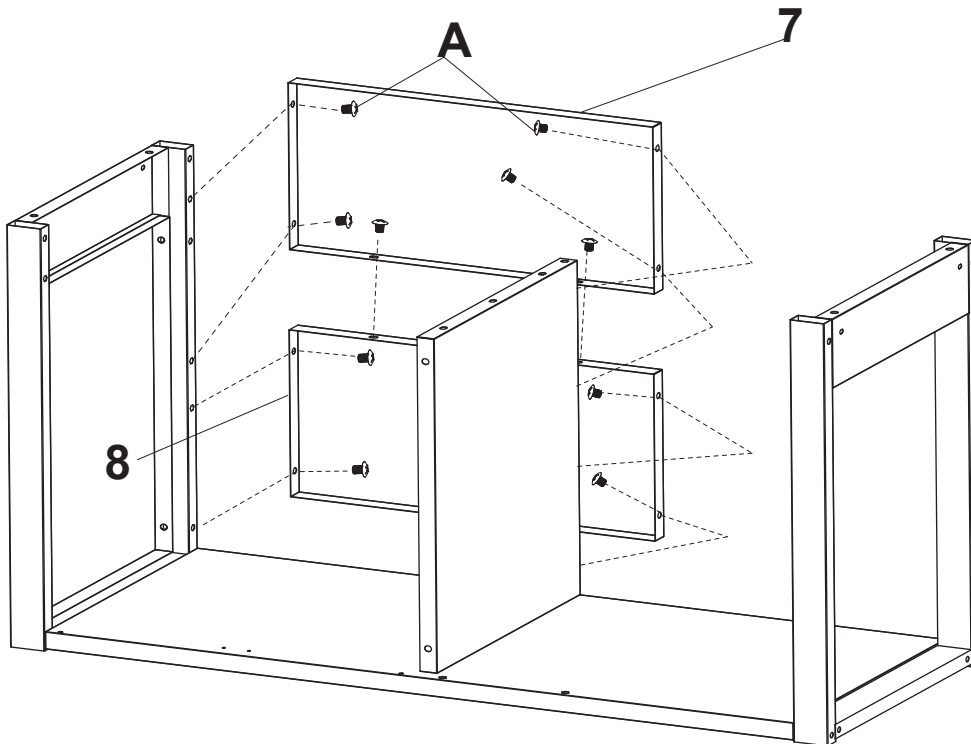

05

A x4

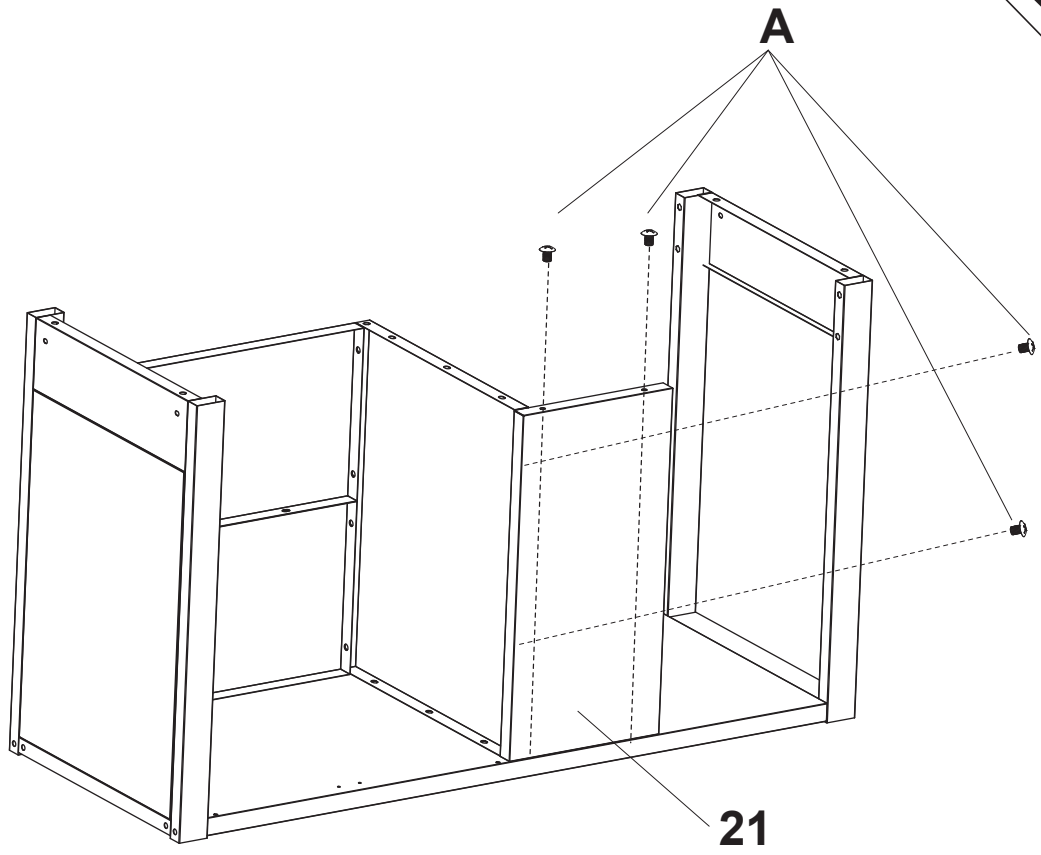

06

A x6

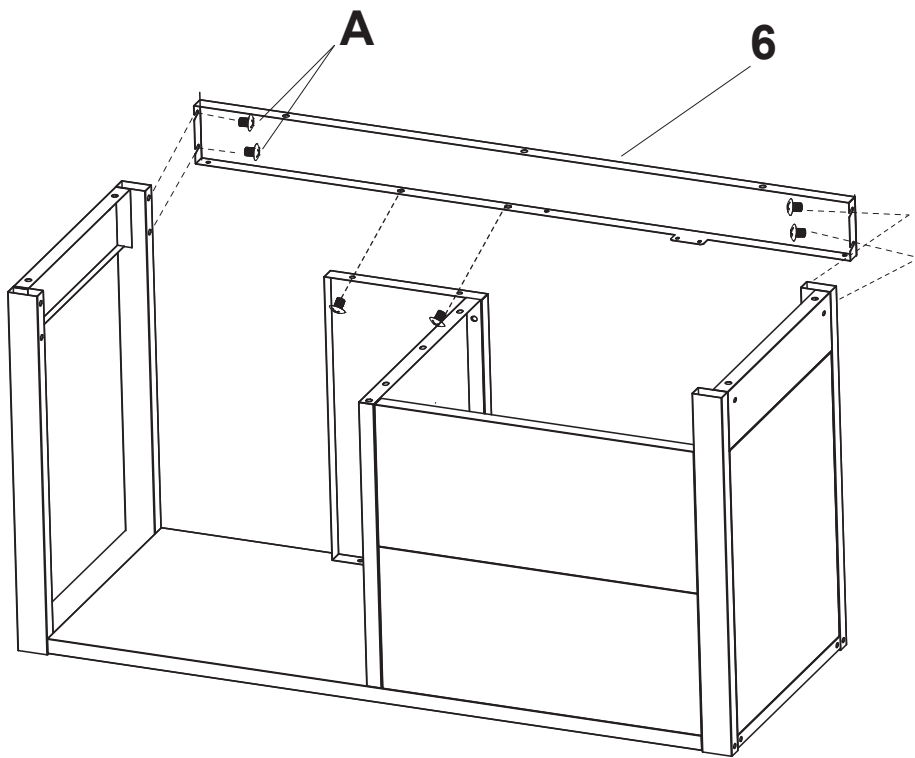

A x5

07

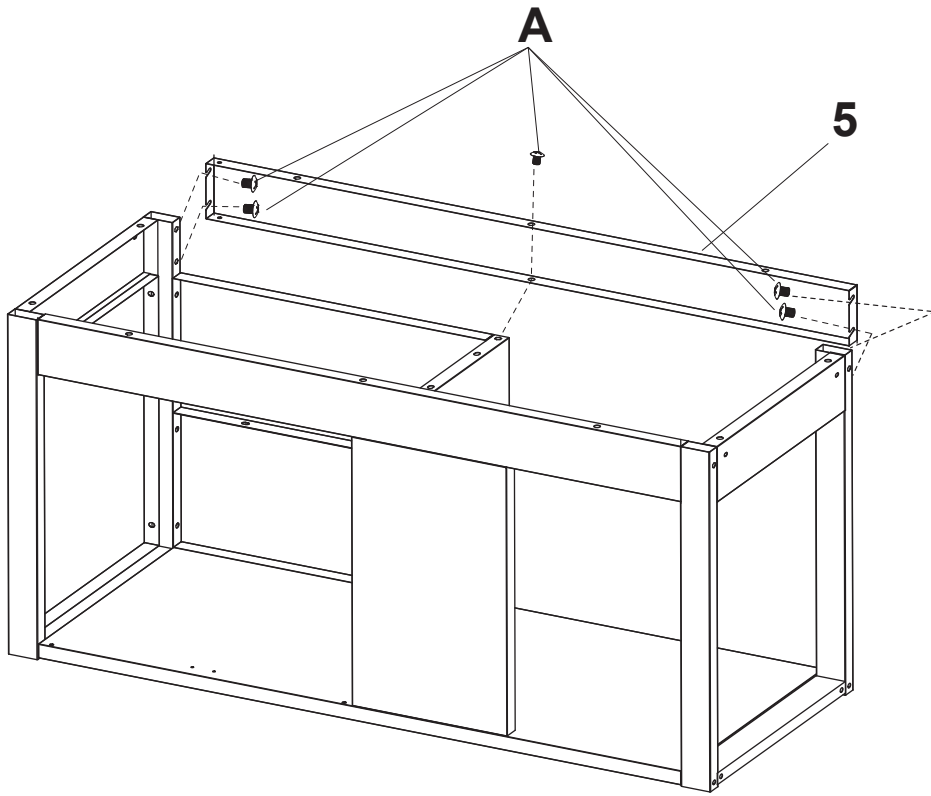

08

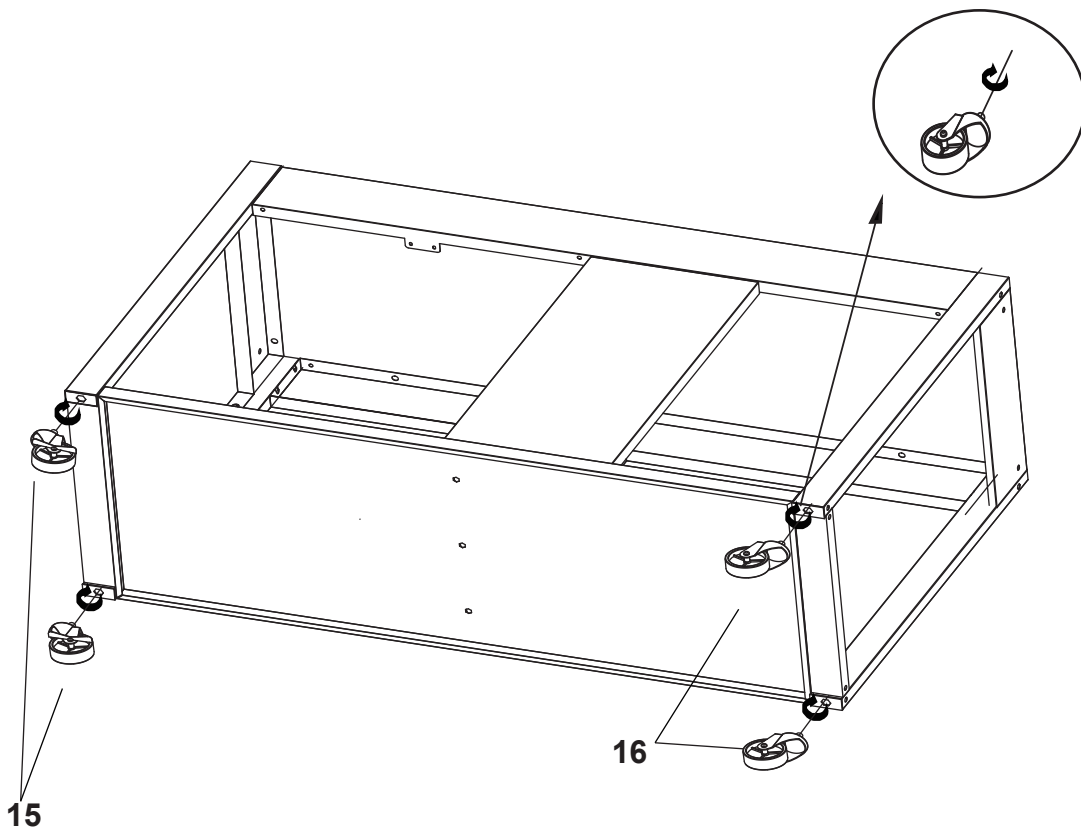

A x3

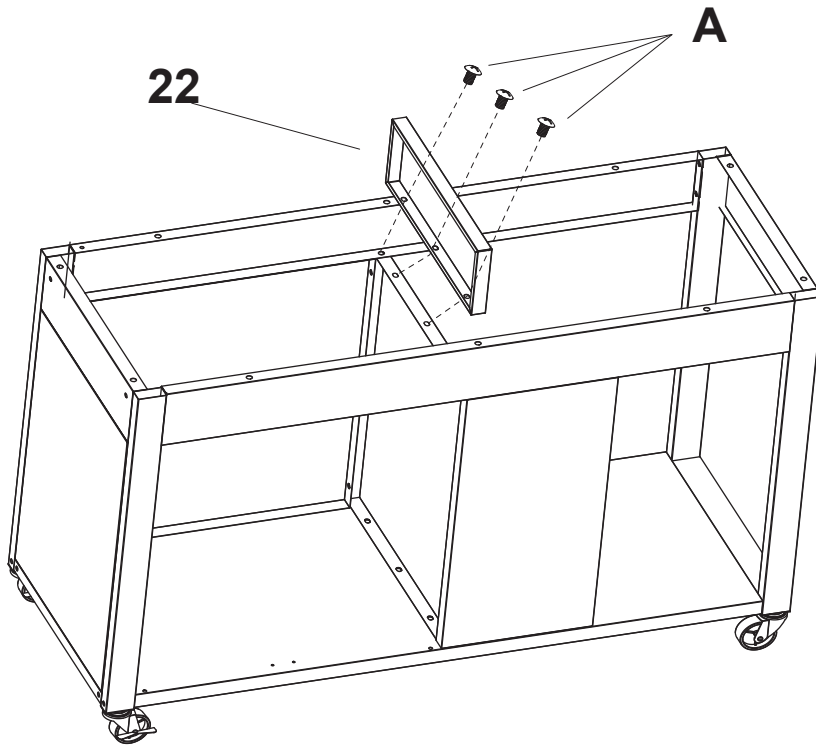

F x2

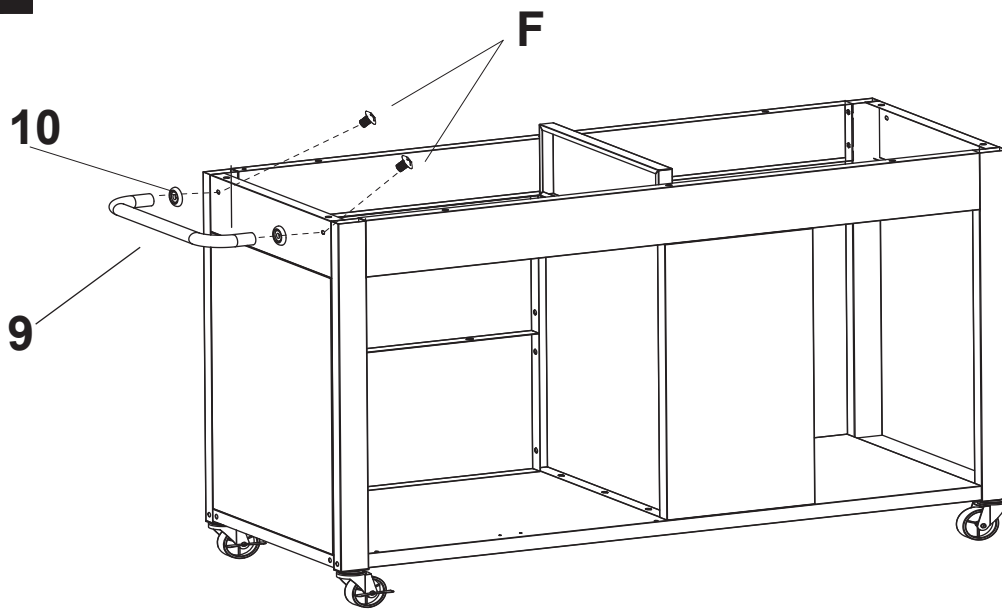

A x8

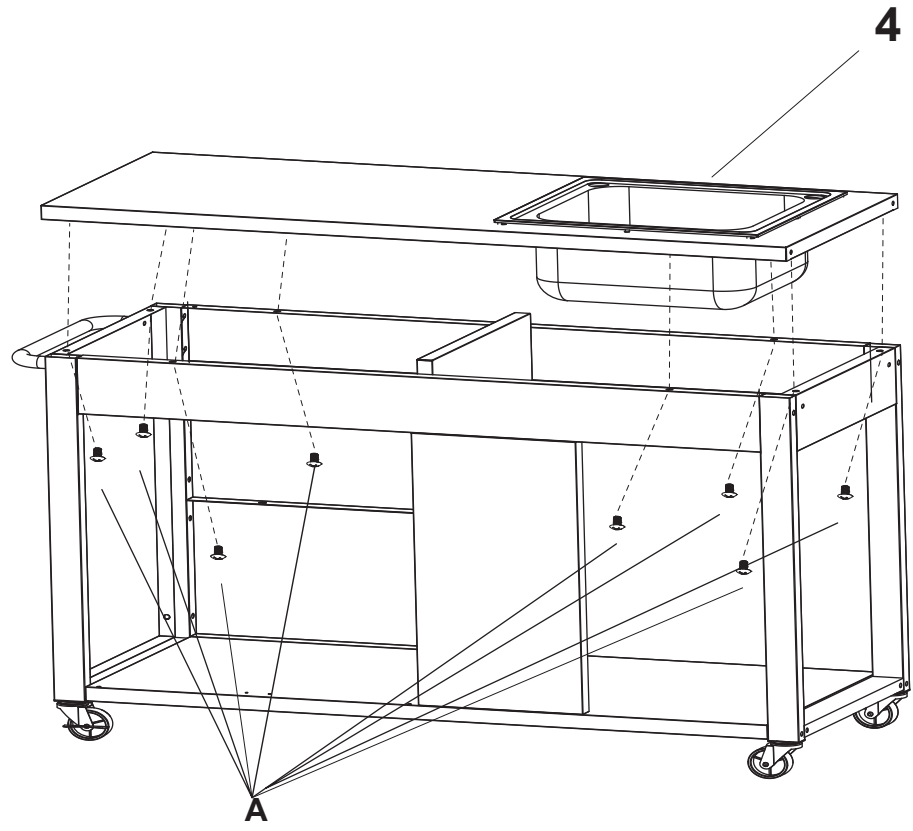

A x4

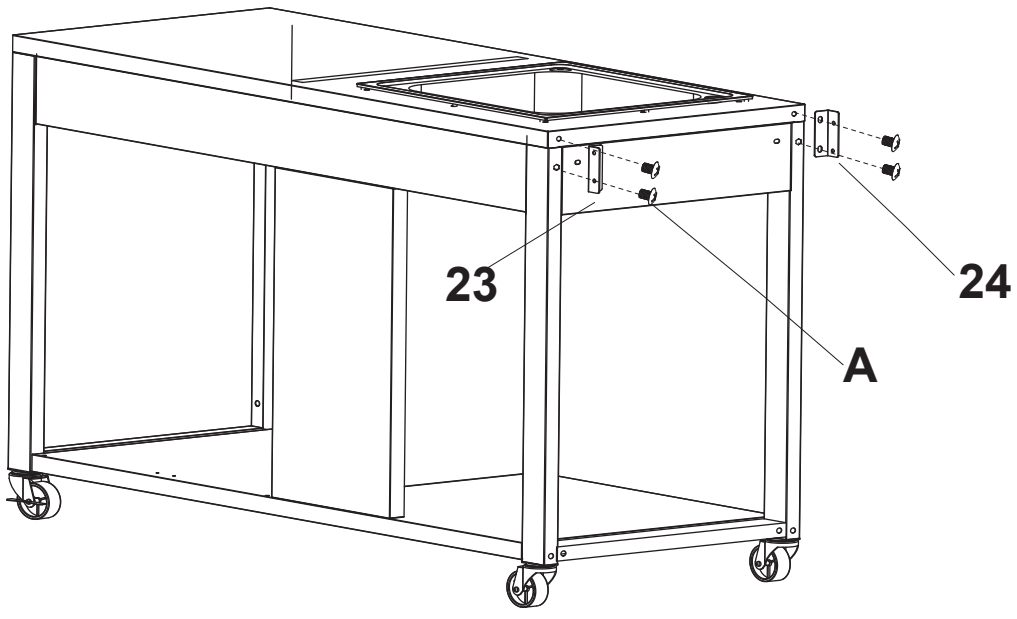

13

- B x4
- D x4

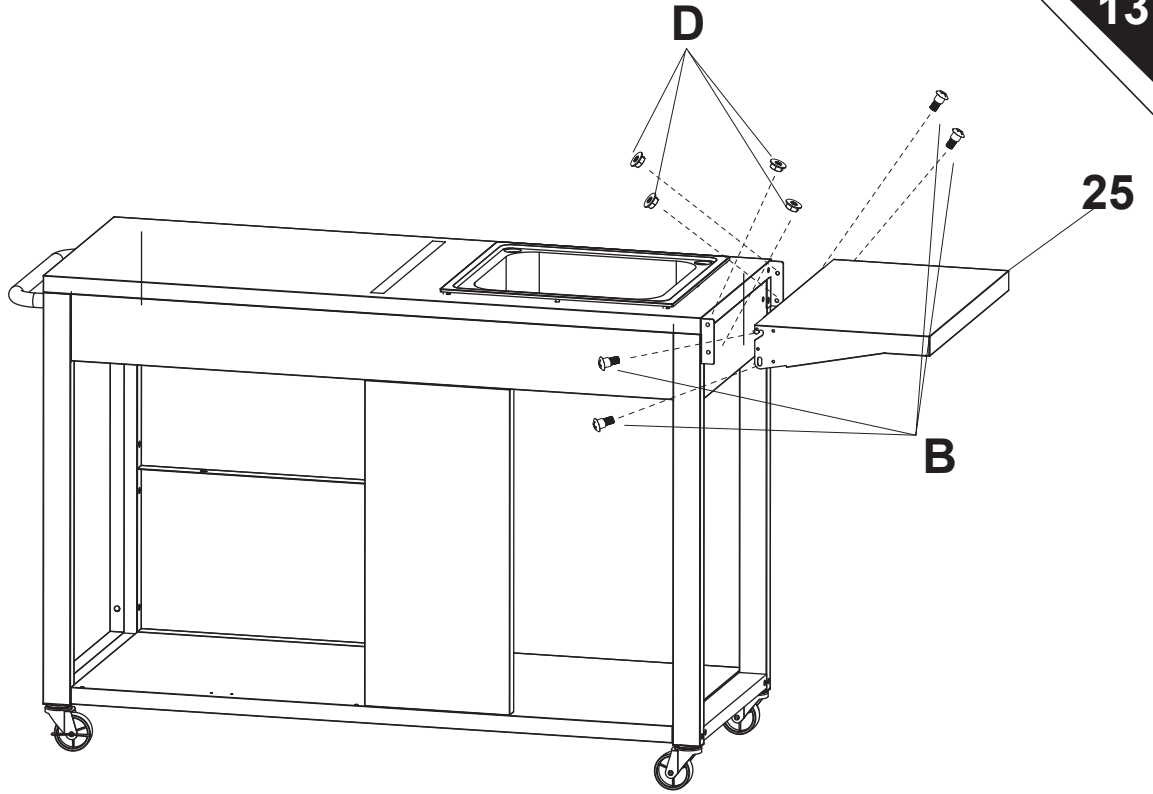

14

- E x4

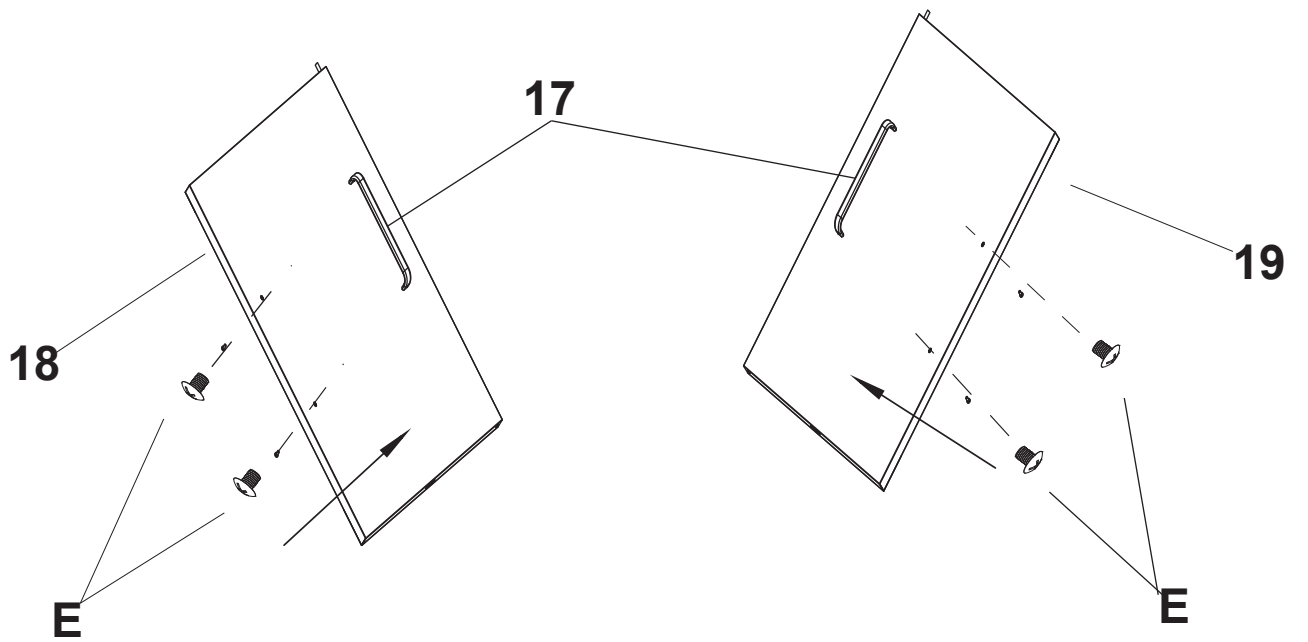

G x4

H x4

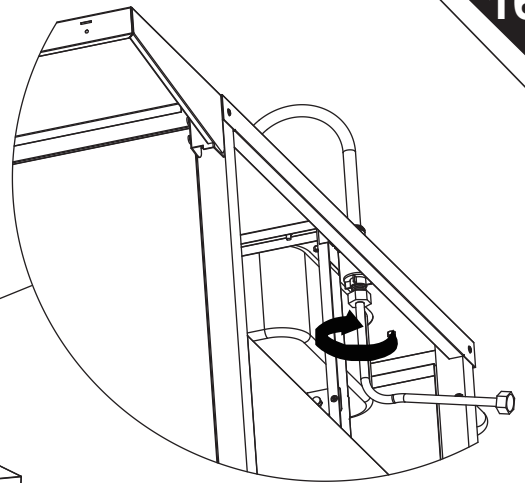
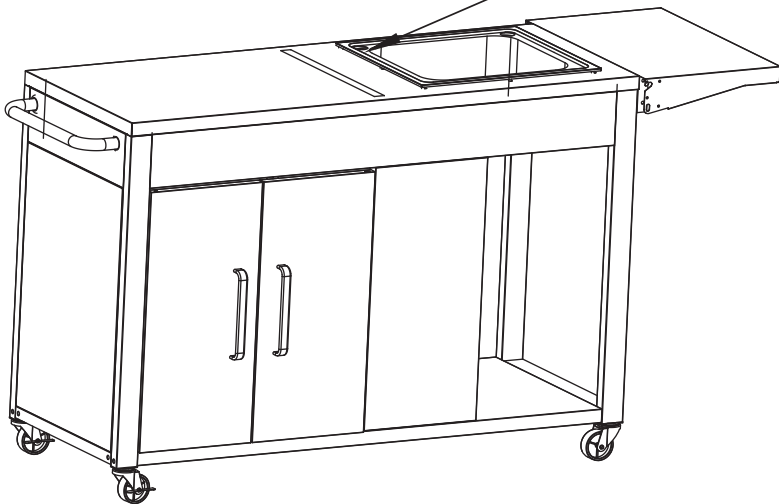
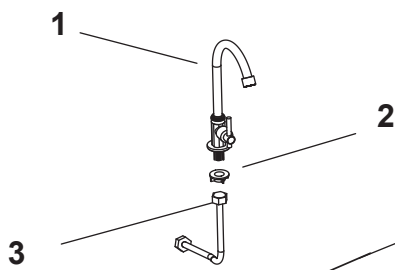
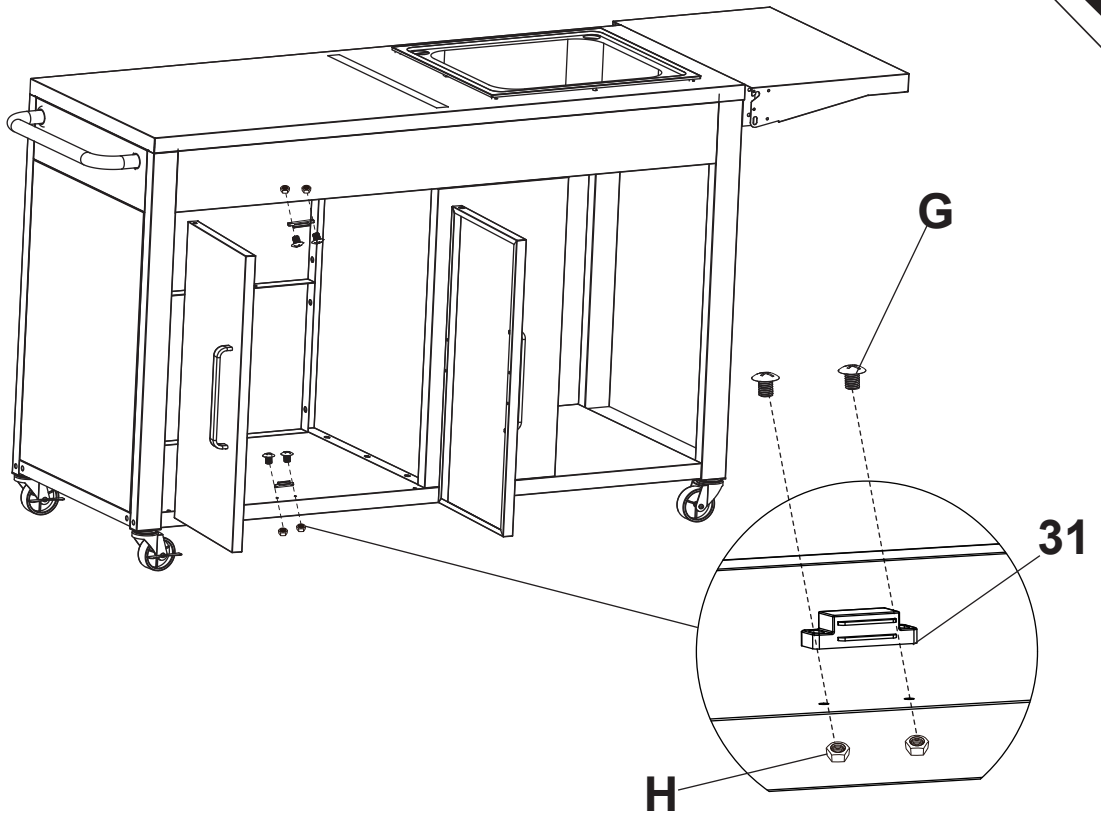

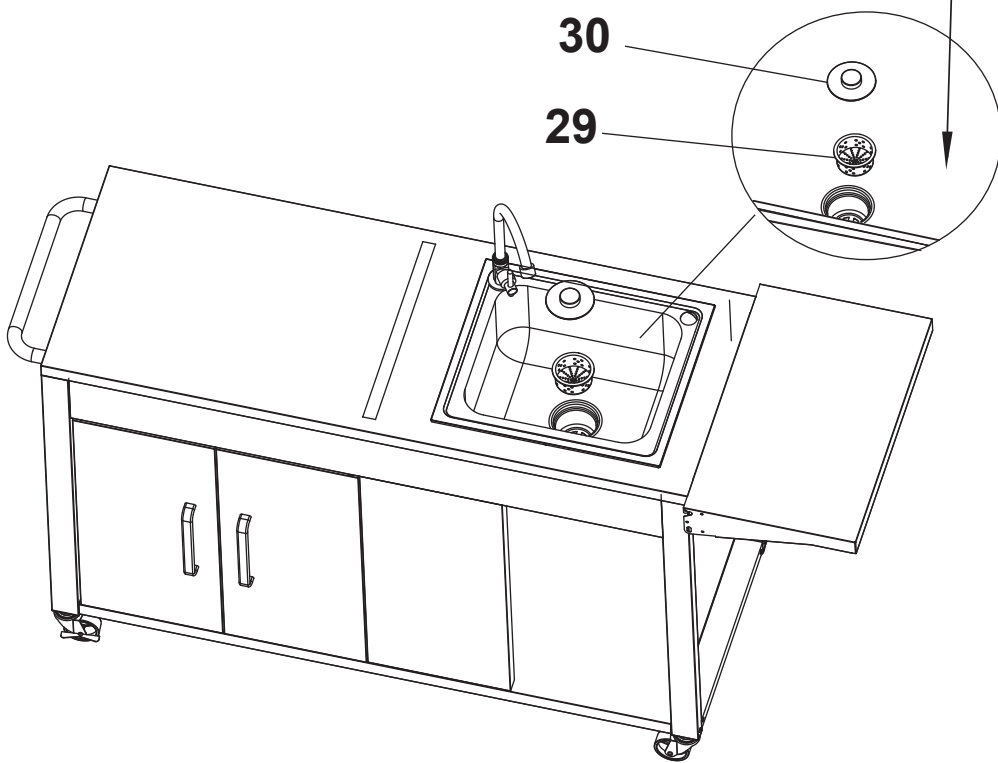
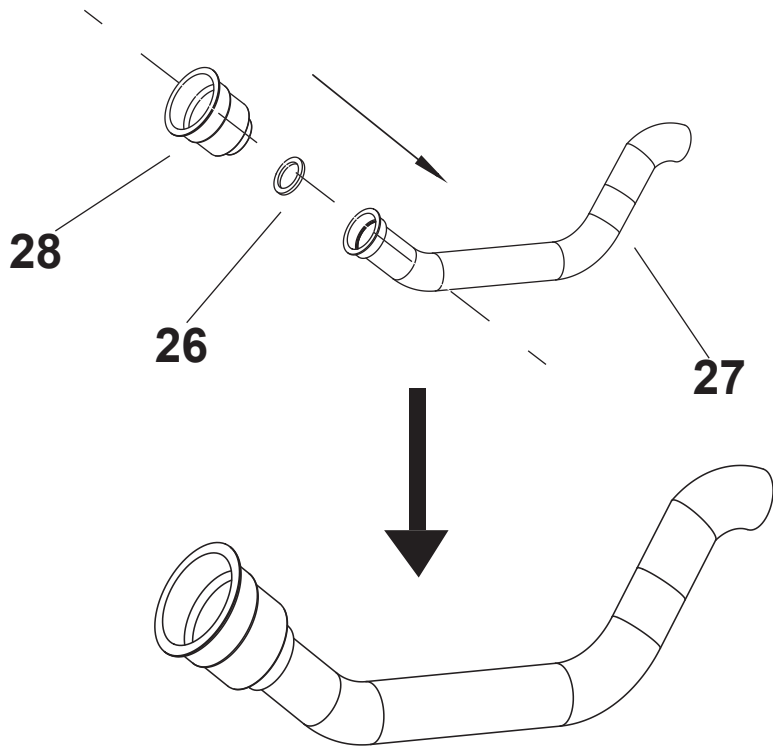

If you have any questions, please contact our customer care center, Our contact details are below:

US

 001-877-644-9366

 customerservice@aosom.com

Imported by Aosom LLC
7777 Center Ave. Suite 430
Huntington Beach, CA 92647-9998 USA
MADE IN CHINA

Si tiene alguna pregunta, comuníquese con nuestro Centro de Atención al Cliente, Nuestros datos de contacto son los siguientes:

ES

 0034-931294512

 atencioncliente@aosom.es

IMPORTADOR/Fabricante/REP:
SPANISH AOSOM, S.L.
C/ROC GROS,Nº15.08550, ELS HOSTALETES DE
BALENYÀ, SPAIN.
B66295775
HECHO EN CHINA

Se tiver alguma dúvida, por favor contacte o nosso Centro de Atendimento ao Cliente, Os nossos dados de contacto são os seguintes:

 0034-931294512

 info@aosom.pt.

IMPORTADOR/Fabricante/REP:
SPANISH AOSOM, S.L.
C.ROC GROS N.15, 08550. ELS HOSTALETES DE
BALENYÀ
FEITO NA CHINA

If you have any questions, please contact our customer care center, Our contact details are below:

CA

 416-792-6088

 customerservice@aosom.ca

Imported by Aosom Canada Inc.
7270 Woodbine Avenue, Unit 307, Markham,
Ontario Canada L3R 4B9
MADE IN CHINA

Si vous avez la moindre question, veuillez contacter notre centre d'assistance à la clientèle, Nos coordonnées sont les suivantes:

 416-792-6088

 customerservice@aosom.ca

Importé par Aosom Canada Inc.
7270 Woodbine Avenue, unité 307,
Markham, Ontario Canada L3R 4B9
FABRIQUÉ EN CHINE

In caso di dubbio, si prega di contattare il nostro centro assistenza clienti, I nostri dettagli di contatto sono di seguito:

IT

 0039-0249471447

 clienti@aosom.it

IMPORTATO DA/Produttore/REP:
AOSOM Italy srl
Centro Direzionale Milanofiori
Strada 1 Palazzo F1
20057 Assago (MI)
P.I.: 08567220960
FATTO IN CINA

If you have any questions, please contact our customer care center, Our contact details are below:

UK

 0044-800-240-4004

 enquiries@mhstar.co.uk

IMPORTER ADDRESS:
MH STAR UK Ltd
1 Northampton Cross Logistics Park
Northampton Cross Road
Northampton
NN4 9FH
MADE IN CHINA

Wenn Sie Fragen haben, wenden Sie sich bitte an unser Kundendienstzentrum, Unsere Kontaktdaten stehen unten:

DE

 0049-0(40)-87408465

 service@aosom.de

ADRESSE DES IMPORTEURE/Hersteller/REP:
MH Handel GmbH
Wendenstraße 309
D-20537 Hamburg
Germany
IN CHINA HERGESTELLT

Si vous avez la moindre question, veuillez contacter notre centre d'assistance à la clientèle, Nos coordonnées sont les suivantes:

FR

 0033-1-84166106

 aosom@mhfrance.fr

Importé par/Fabricant/REP:
MH FRANCE
2 Rue Maurice Hartmann
92130 Issy Les Moulineaux
France
FABRIQUÉ EN CHINE



FR

**DONNEZ
OU
RECYCLEZ**



ASSOCIATION

OU



LIVRAISON

OU



DÉCHÈTERIE

Adresses sur quefairedemesdechets.fr