

PawHut

IN241100206V01

D00-210V00_D00-210V01



6

STEPS



10 MIN

EN_ IMPORTANT, RETAIN FOR FUTURE REFERENCE: READ CAREFULLY.

FR_ IMPORTANT: A LIRE ATTENTIVEMENT ET À CONSERVER POUR CONSULTATION ULTÉRIEURE.

ES_ IMPORTANTE, LEA Y GUARDE PARA FUTURAS REFERENCIAS.

PT_ IMPORTANTE: LEIA ATENTAMENTE E GUARDE PARA CONSULTA FUTURA.

DE_ WICHTIG! SORGFÄLTIG LESEN UND FÜR SPÄTER NACHSCHLAGEN AUFBEWAHREN.

IT_ IMPORTANTE! CONSERVARE IL PRESENTE MANUALE PER FUTURO RIFERIMENTO E LEGGERLO ATTENTAMENTE.

RO_ IMPORTANT: CITIȚI CU ATENȚIE ȘI PĂSTRAȚI PENTRU CONSULTARE VIITOARE.

WARNING:Keep Away From Fire

- 1.Please read this instruction carefully before use and keep it properly for future reference. If you do not follow this instruction, the safety of pets may be affected.
- 2.Do not leave the caregiver while the product is in use.
- 3.Do not use accessories not provided by the manufacturer.
- 4.Any load attached to the handle will affect the stability of the pet stroller.
- 5.Ensure that all the locking devices are assembled before using the pet stroller.
- 6.Pets must use restraints when using.
- 7.Do not use the pet stroller in rough areas, near stoves and other dangerous areas.
- 8.Avoid use or storage in damp, cold or high temperature environment and keep away from fire or strong heat source.
- 9.Do not use it to put dangerous animals which are aggressive and destructive.

Maintenance and Care

Please check and maintain the pet stroller frequently. The cloth cover cannot be dipped and washed. When the cloth cover is cleaned, please use a brush and other cleaning instruments to clean the dirt.

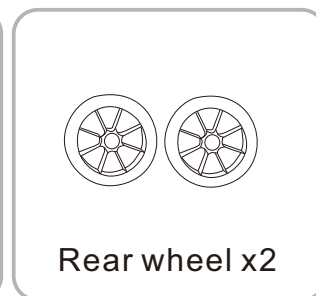
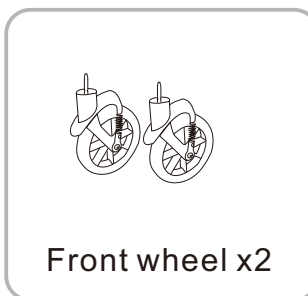
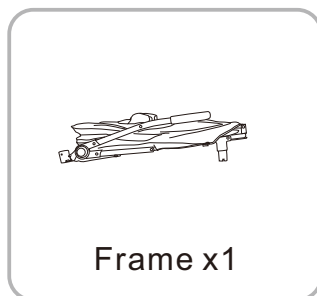
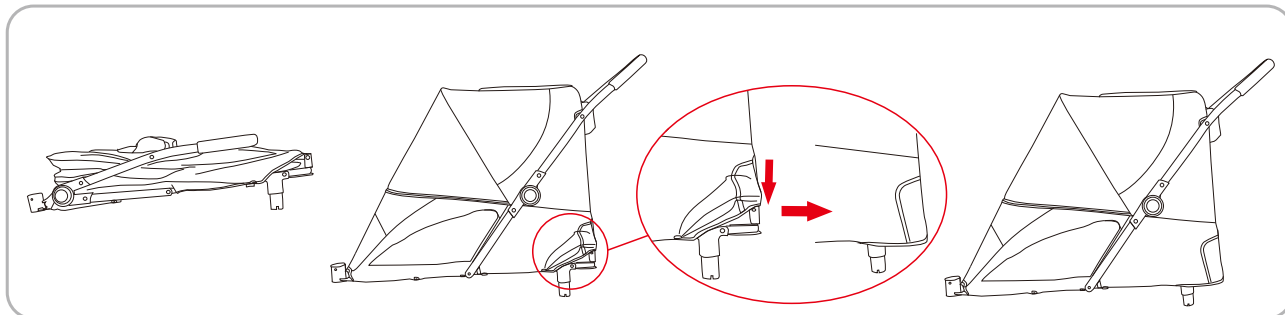
Parts**Directions for use****1.Unfolding frame**

Take out the frame, hold the handlebar with both hands and lift it up until a click is heard which means the frame is fully open. After opening the frame, adjust the lower side cover to make it flat.

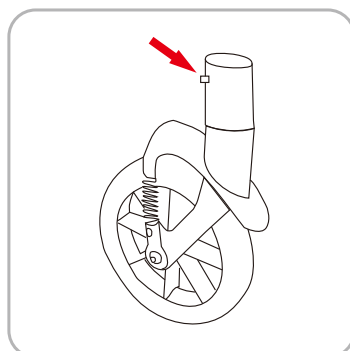
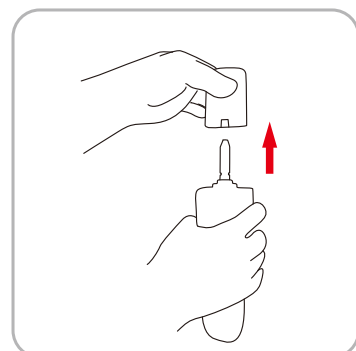

2.Assembly and disassembly of the front wheel As shown in the picture, insert the front wheel into the hole of the front wheel upper seat until you hear a "click". To disassemble, press the disassembly button and pull it down.

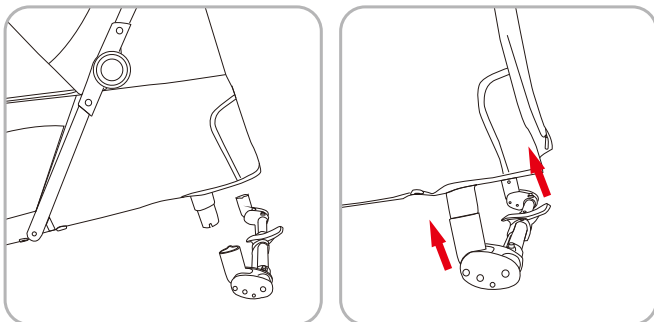

3. Assembly and disassembly of the rear wheel As shown in the picture, first put the rear wheel brake seat into the rear wheel upper seat, and the wheel seat shrapnel on both sides will pop out; then install the rear wheel into the rear wheel seat hole until you hear a "click".

When disassembly is required, press the disassembly button and pull out the rear wheel.

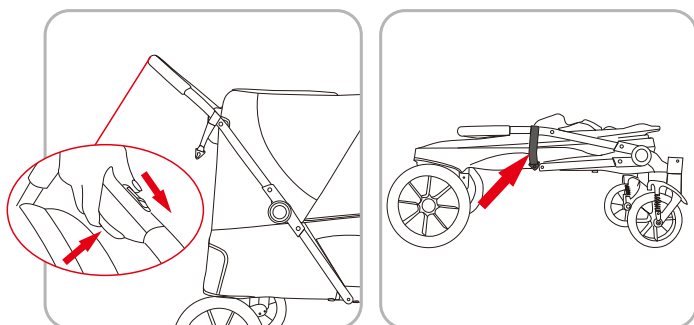
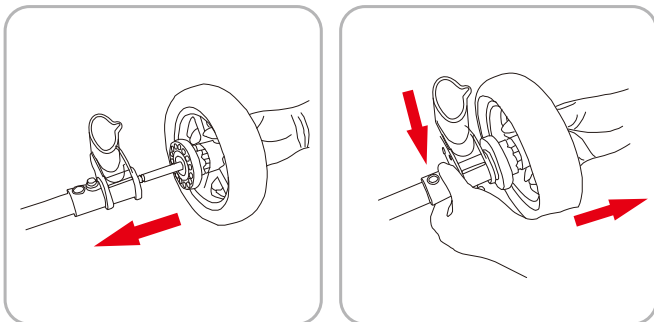

4. Folding frame

When in the brake state, hold the handlebar with one hand, push the unlocking button on the handlebar tube to the left, then press the frame folding button, press down the frame, and the frame can be folded. After folding the frame, buckle the frame folding hook.

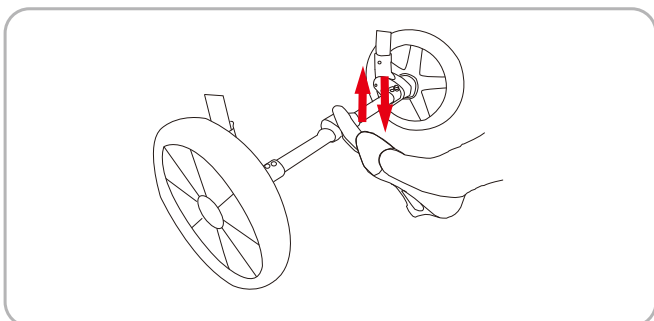

5. Use of rear wheel brake lever Press down the brake pedal, the brake works. Conversely, it can be released.

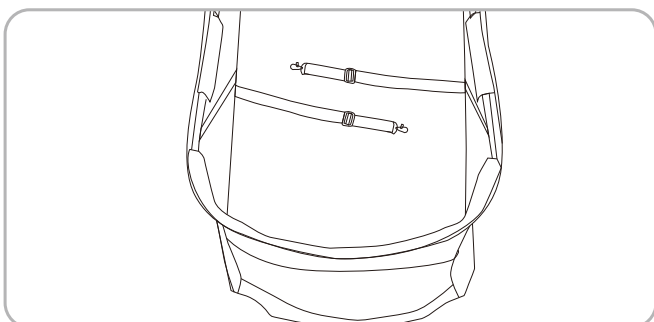

6. For pet safety belts

AVERTISSEMENT : À Garder à l'Écart Du Feu

1. Prière de lire attentivement ces instructions avant l'utilisation et de les conserver pour s'y référer ultérieurement. Le non-respect de ces instructions peut affecter la sécurité des animaux domestiques.
2. Le gardien ne doit pas s'absenter pendant l'utilisation de l'appareil.
3. Ne pas utiliser d'accessoires non fournis par le fabricant.
4. La stabilité de la poussette est affectée par toute charge fixée à la poignée.
5. S'assurer que tous les dispositifs de verrouillage sont assemblés avant d'utiliser la poussette pour animaux.
6. Les animaux domestiques doivent être attachés lors de l'utilisation.
7. Ne pas utiliser la poussette dans des endroits rugueux, à proximité de foyers ou d'autres endroits dangereux.
8. Éviter d'utiliser ou de ranger la poussette dans un environnement humide, froid ou à haute température et la tenir éloignée du feu ou d'une source de chaleur intense.
9. La poussette ne doit pas être utilisée pour transporter des animaux dangereux, agressifs et nuisibles.

Maintenance et Entretien

La poussette doit être vérifiée et entretenue fréquemment. La housse en tissu ne doit pas être trempée ni lavée. Lorsque la housse en tissu doit être nettoyée, prière d'utiliser une brosse et d'autres instruments de nettoyage pour enlever la saleté.

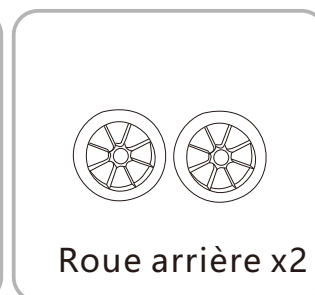
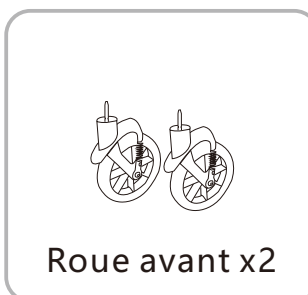
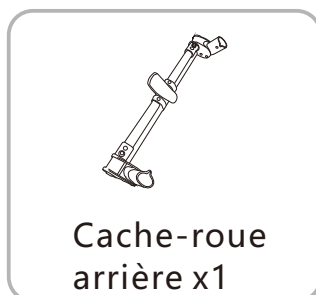
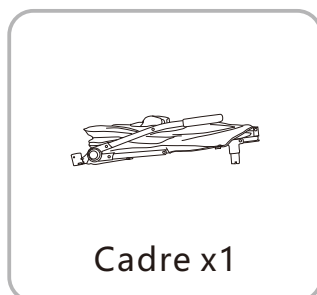
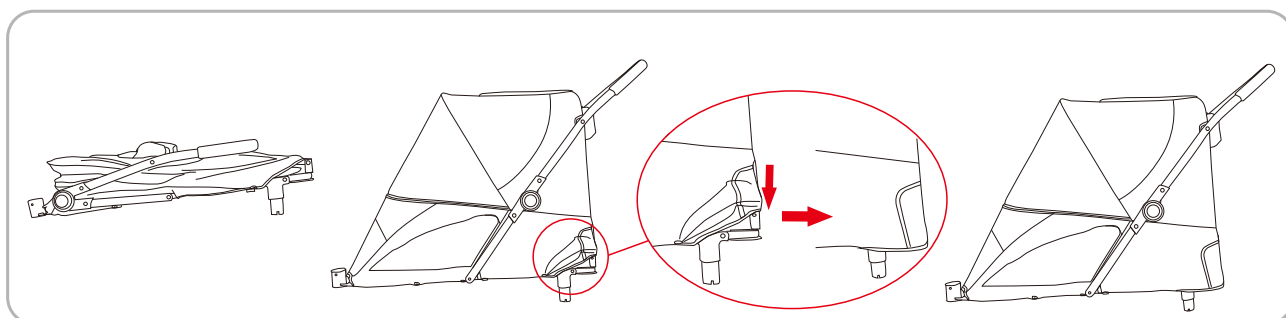
Pièces**Mode d'emploi****1. déplier le cadre**

Sortez le cadre, tenez le guidon à deux mains et soulevez-le jusqu'à ce que vous entendiez un déclic, ce qui signifie que le cadre est complètement ouvert. Après avoir ouvert le cadre, ajustez le couvercle latéral inférieur pour le rendre plat.

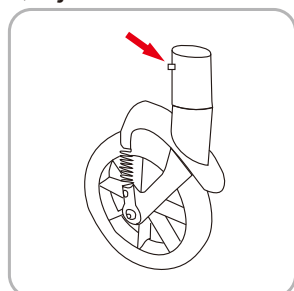
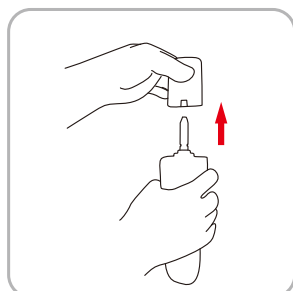
**2. Montage et démontage de la roue avant**

Comme indiqué sur l'image, insérez la roue avant dans le trou du siège supérieur de la roue avant jusqu'à ce que vous entendiez un « clic ». Pour la démonter, appuyez sur le bouton de démontage et tirez-la vers le bas.

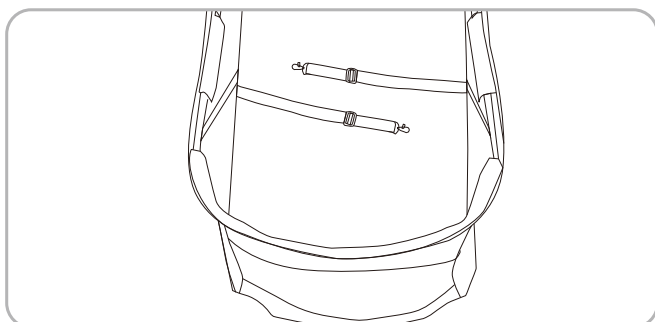
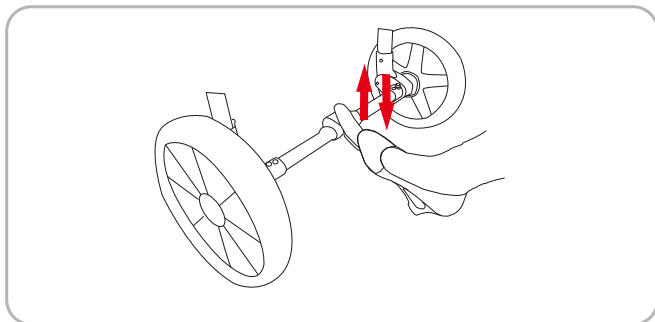
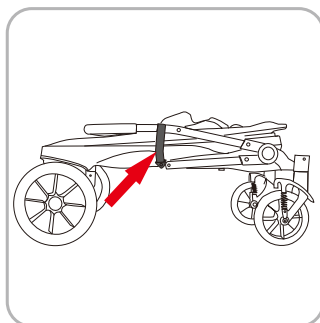
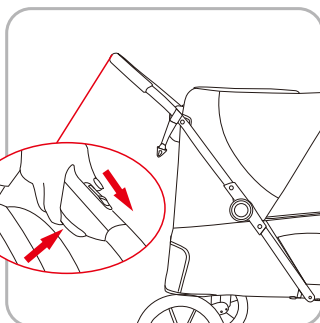
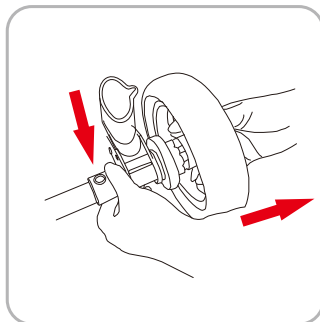
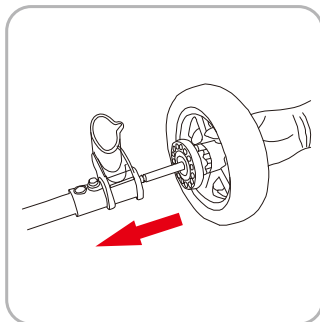
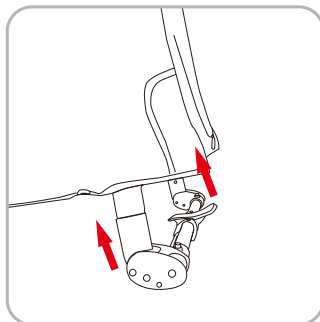
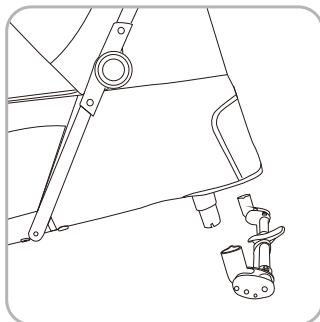

3. Montage et démontage de la roue arrière Comme le montre l'image, insérez d'abord le siège du frein de la roue arrière dans le siège supérieur de la roue arrière, et les éclats du siège de la roue des deux côtés sortiront ; installez ensuite la roue arrière dans le trou du siège de la roue arrière jusqu'à ce que vous entendiez un « clic ». Lorsque le démontage est nécessaire, appuyer sur le bouton de démontage et retirer la roue arrière.

4. plier le cadre

Lorsque le vélo est freiné, tenez le guidon d'une main, poussez le bouton de déverrouillage sur le tube du guidon vers la gauche, puis appuyez sur le bouton de pliage du cadre, appuyez sur le cadre, et le cadre peut être plié. Après avoir plié le cadre, bouclez le crochet de pliage du cadre.

5. Utilisation du levier de frein de la roue arrière Appuyez sur la pédale de frein, le frein fonctionne. Inversement, il peut être desserré.

6. pour les ceintures de sécurité des animaux de compagnie

ADVERTENCIA: Mantener alejado del fuego

1. Por favor, lea atentamente estas instrucciones antes de usar el aparato y guárdelas para futuras consultas. Si no sigue estas instrucciones, la seguridad de las mascotas puede verse afectada.
2. No deje al cuidador mientras el producto está en uso.
3. No utilice accesorios no proporcionados por el fabricante.
4. Cualquier carga fijada al mango afectará la estabilidad del cochecito para mascotas.
5. Asegúrese de que todos los dispositivos de bloqueo estén montados antes de usar la silla de paseo para mascotas.
6. Los animales domésticos deben ir sujetos cuando se esté usando el producto.
7. No use el cochecito para mascotas en zonas abruptas, cerca de estufas y otras zonas peligrosas.
8. Evite el uso o el almacenamiento en ambientes húmedos, fríos o con altas temperaturas y manténgalo alejado del fuego o de fuentes de calor fuertes.
9. No lo utilice para colocar animales peligrosos que sean agresivos y destructivos.

Mantenimiento y Cuidado

Por favor, compruebe y mantenga el cochecito para mascotas con frecuencia. La funda de tela no se puede sumergir ni lavar. Cuando se limpie la cubierta de tela, por favor, utilice un cepillo y otros instrumentos de limpieza para limpiar la suciedad.

Piezas



Instrucciones de uso

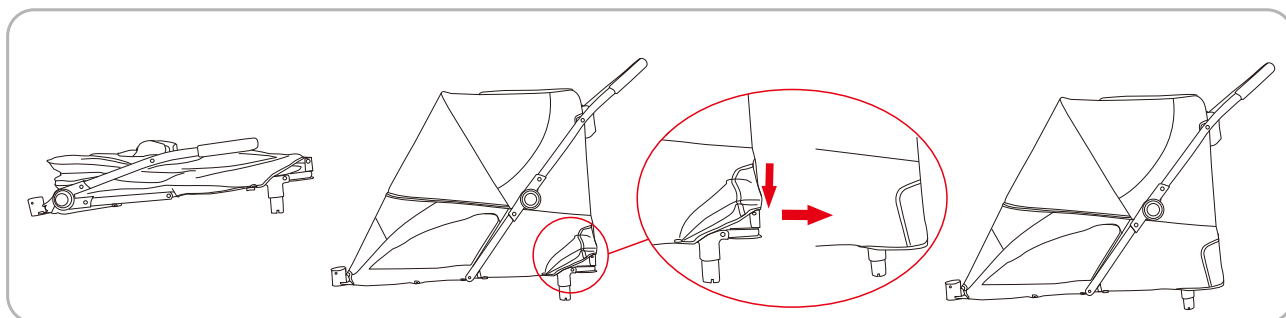

1. Despliegue del cuadro

Saque el cuadro, sujete el manillar con ambas manos y levántelo hasta que se oiga un clic, lo que significa que el cuadro está completamente abierto. Después de abrir el cuadro, ajuste la cubierta lateral inferior para que quede plana.

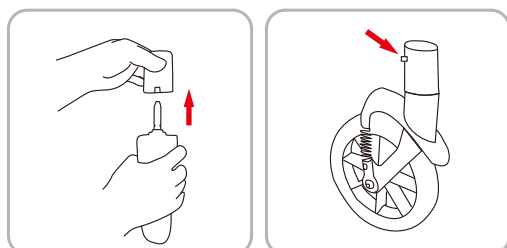

2. Montaje y desmontaje de la rueda delantera

Como se muestra en la imagen, inserte la rueda delantera en el orificio del asiento superior de la rueda delantera hasta que oiga un « clic ». Para desmontarla, pulse el botón de desmontaje y tire hacia abajo.

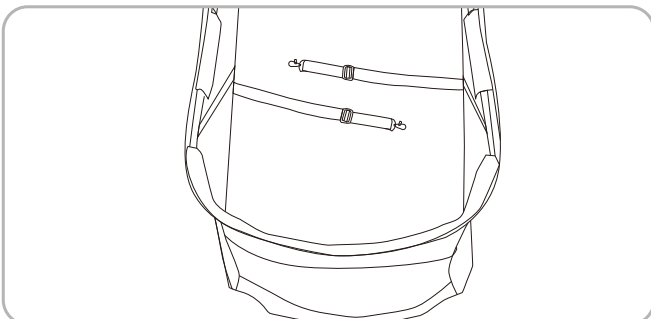
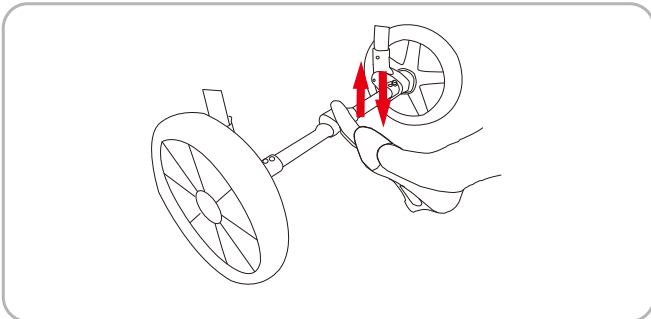
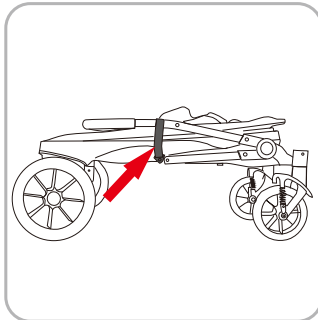
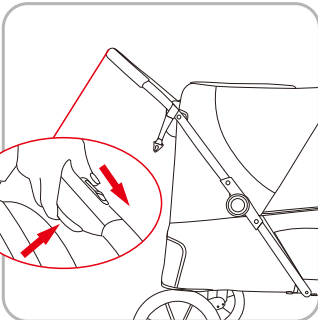
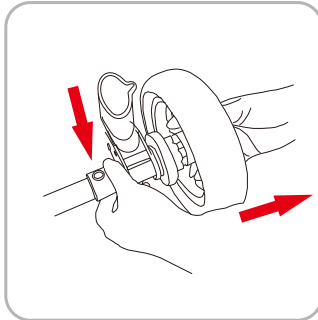
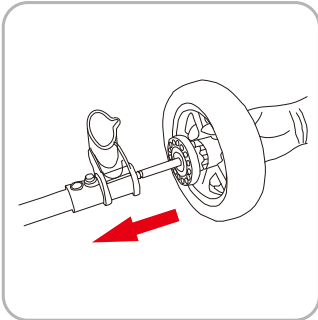
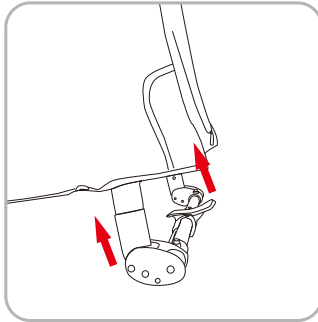
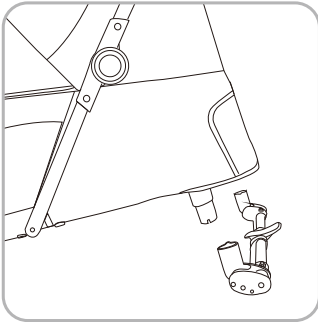

3. Montaje y desmontaje de la rueda trasera Como se muestra en la imagen, primero coloque el asiento del freno de la rueda trasera en el asiento superior de la rueda trasera, y la metralla del asiento de la rueda de ambos lados saldrá; a continuación, instale la rueda trasera en el orificio del asiento de la rueda trasera hasta que oiga un «clic». Cuando sea necesario desmontarla, pulse el botón de desmontaje y extraiga la rueda trasera.

4. Plegado del cuadro Cuando esté en estado de frenado, sujete el manillar con una mano, presione el botón de desbloqueo del tubo del manillar hacia la izquierda y, a continuación, presione el botón de plegado del cuadro, presione hacia abajo el cuadro y éste podrá plegarse. Después de plegar el cuadro, abraque el gancho de plegado del cuadro.

5. Uso de la palanca de freno de la rueda trasera Presione el pedal de freno, el freno funciona. A la inversa, puede soltarse.

6. Cinturones de seguridad para mascotas

AVISO: Mantenha-se Longe do Fogo

1. Por favor leia esta instrução cuidadosamente antes de usar e guarde-a devidamente para referência futura. Se não seguir estas instruções, a segurança dos animais de estimação pode ser afetada.
2. Não deixe o prestador de cuidados enquanto o produto estiver em uso.
3. Não utilize acessórios não fornecidos pelo fabricante.
4. Qualquer carga presa à pega afetará a estabilidade do carrinho do animal.
5. Certifique-se de que todos os dispositivos de bloqueio estão montados antes de usar o carrinho de passeio para animais domésticos.
6. Animais de estimação devem usar trelas.
7. Não use o carrinho de passeio em áreas ásperas, perto de fogões e outras áreas perigosas.
8. Evitar o uso ou armazenamento em ambientes húmidos, frios ou de alta temperatura e manter longe de fogo ou fonte de calor forte.
9. Não o utilize para colocar animais perigosos que sejam agressivos e destrutivos.

Manutenção e Cuidados

Por favor, verifique e mantenha o carrinho de passeio frequentemente. A cobertura do pano não pode ser mergulhada e lavada. Quando a cobertura do pano for limpa, por favor use uma escova e outros instrumentos de limpeza para limpar a sujidade.

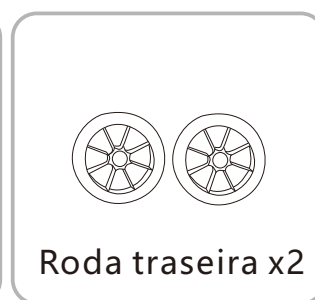
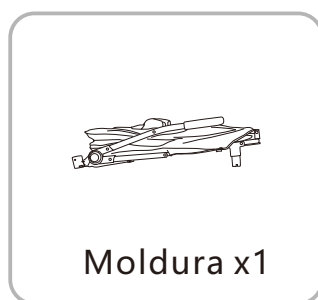
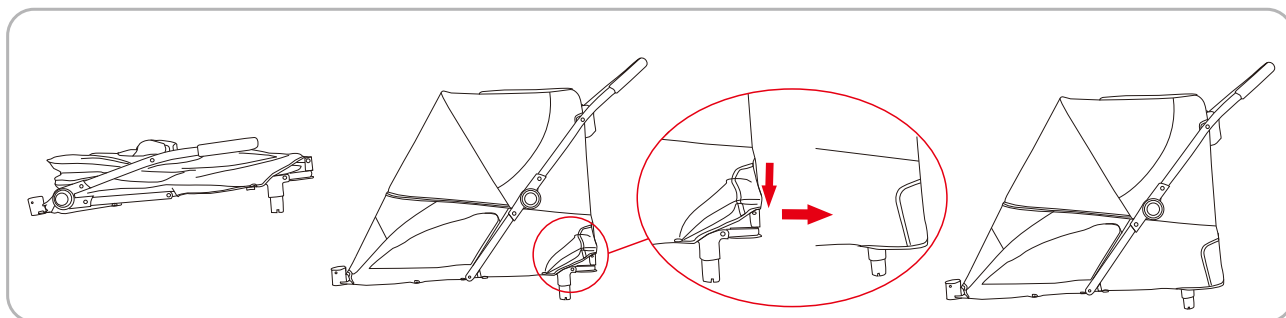
Partes**Modo de utilização****1. desdobrar o quadro**

Retire o quadro, segure o guidador com as duas mãos e levante-o até ouvir um clique, o que significa que o quadro está totalmente aberto. Depois de abrir o quadro, ajuste a tampa lateral inferior para a tornar plana.

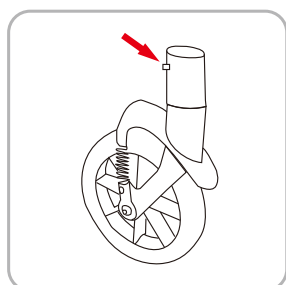
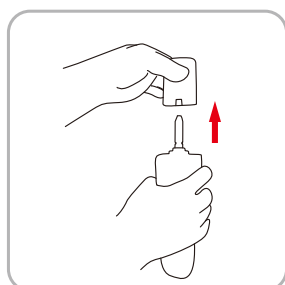

2. Montagem e desmontagem da roda dianteira Como mostra a figura, insira a roda dianteira no orifício do assento superior da roda dianteira até ouvir um "clique". Para desmontar, prima o botão de desmontagem e puxe-o para baixo.

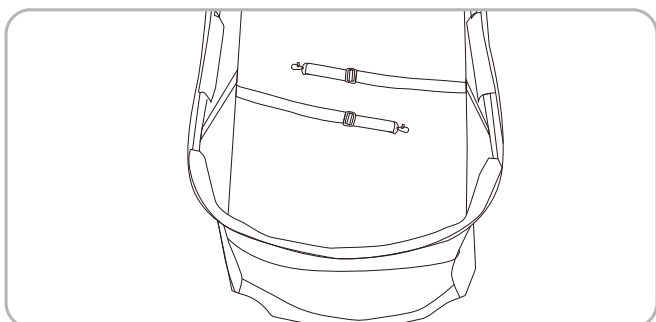
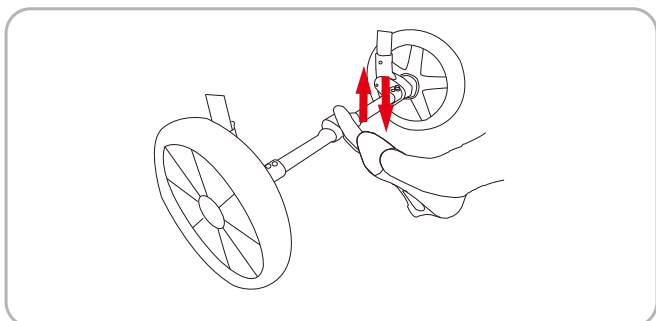
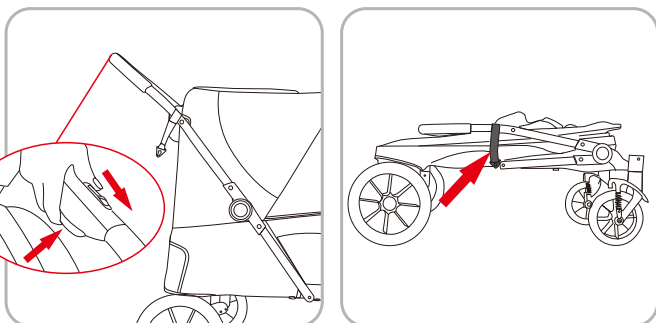
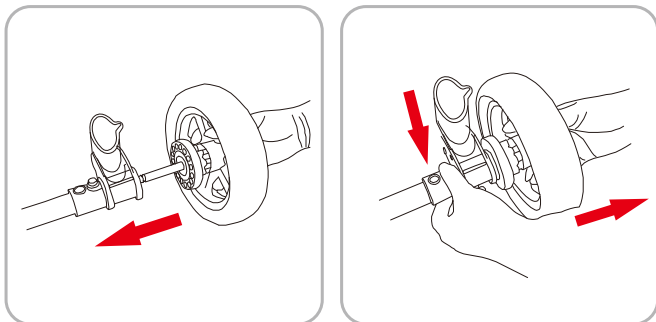
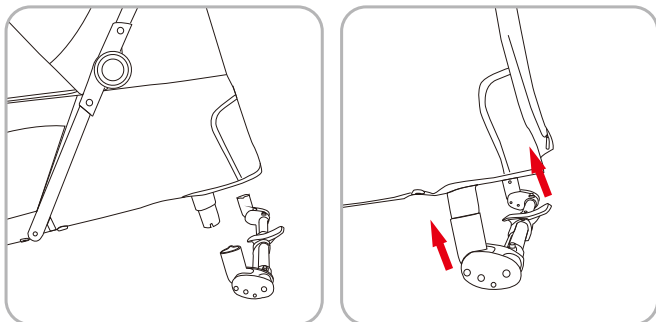

3. montagem e desmontagem da roda traseira Como mostra a figura, comece por colocar o assento do travão da roda traseira no assento superior da roda traseira, e os estilhaços do assento da roda de ambos os lados saltarão para fora; em seguida, instale a roda traseira no orifício do assento da roda traseira até ouvir um “clique”. Quando for necessário desmontar, prima o botão de desmontagem e puxe a roda traseira para fora.

4. dobrar o quadro Quando estiver no estado de travagem, segure o guiador com uma mão, empurre o botão de desbloqueio no tubo do guiador para a esquerda e, em seguida, prima o botão de dobragem do quadro, prima o quadro para baixo e o quadro pode ser dobrado. Depois de dobrar o quadro, aperte o gancho de dobragem do quadro.

5. utilização da alavanca do travão da roda traseira Pressione o pedal do travão para baixo, o travão funciona. Por outro lado, pode ser libertado.

6. para cintos de segurança para animais de estimação

WARNUNG: Von Feuer fernhalten

1. Bitte lesen Sie diese Anweisung vor der Verwendung sorgfältig durch und bewahren Sie sie zum späteren Nachschlagen auf. Wenn Sie diese Anweisung nicht befolgen, kann die Sicherheit von Haustieren beeinträchtigt werden.
2. Während der Verwendung des Produkts darf sich die Betreuungsperson nicht entfernen.
3. Verwenden Sie kein Zubehör, das nicht vom Hersteller bereitgestellt wird.
4. Jede an der Lenkstange befestigte Last beeinträchtigt die Stabilität des Hundebuggys.
5. Stellen Sie sicher, dass alle Verriegelungsvorrichtungen vor der Verwendung des Hundebuggys montiert sind.
6. Haustiere müssen bei der Verwendung angeschnallt sein.
7. Verwenden Sie den Hundebuggy nicht in rauen Gegenden, in der Nähe von Öfen oder anderen gefährlichen Bereichen.
8. Verwenden oder lagern Sie ihn nicht in feuchten, kalten oder heißen Umgebungen und halten Sie ihn von Feuer oder starken Wärmequellen fern.
9. Verwenden Sie ihn nicht für gefährliche Tiere, die aggressiv und zerstörerisch sind.

Wartung und Pflege

Bitte überprüfen und warten Sie den Hundebuggy regelmäßig. Das Verdeck kann nicht getaucht und gewaschen werden. Wenn Sie das Verdeck reinigen, verwenden Sie bitte eine Bürste und andere Reinigungsmittel, um den Schmutz zu entfernen.

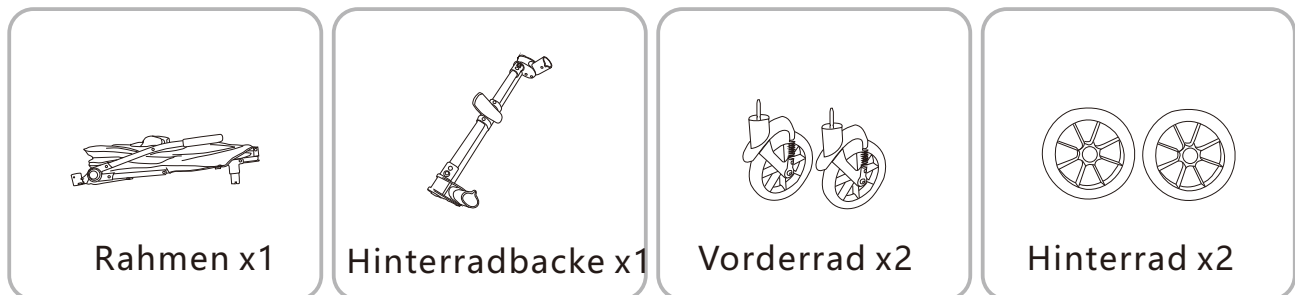
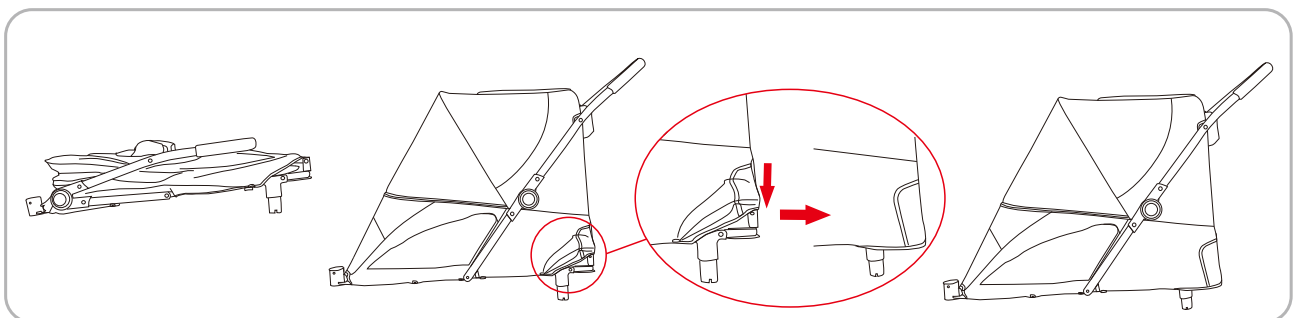
Teile**Gebrauchsanweisung****1. den Rahmen aufklappen**

Nehmen Sie den Rahmen heraus, halten Sie den Lenker mit beiden Händen und heben Sie ihn an, bis ein Klicken zu hören ist, was bedeutet, dass der Rahmen vollständig geöffnet ist. Nachdem Sie den Rahmen geöffnet haben, stellen Sie die untere Seitenabdeckung so ein, dass sie flach ist.

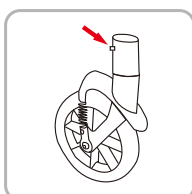
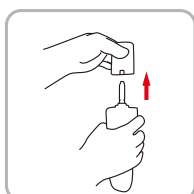

2. montieren und demontieren des Vorderrads Wie in der Abbildung gezeigt, setzen Sie das Vorderrad in die Öffnung des oberen Vorderradsitzes ein, bis Sie ein „Klick“ hören. Zur Demontage drücken Sie den Demonteknopf und ziehen ihn nach unten.

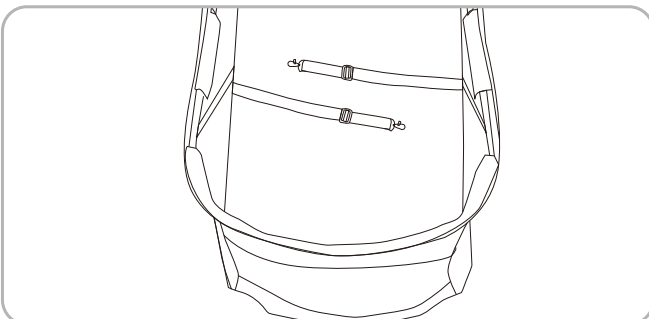
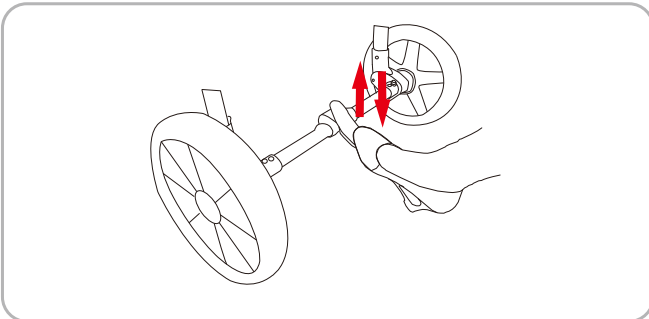
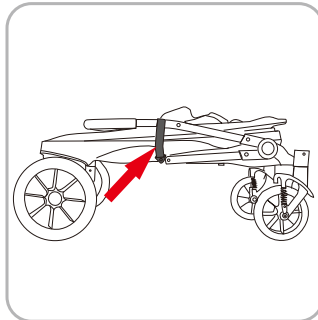
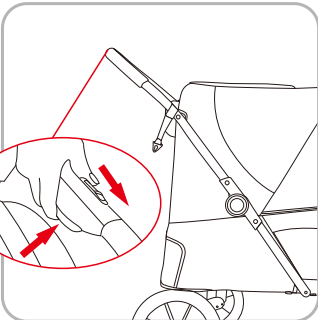
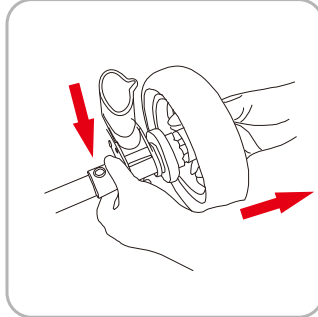
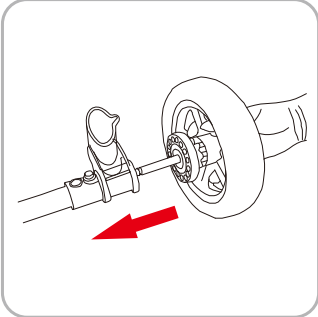
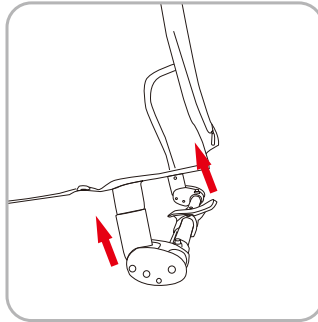
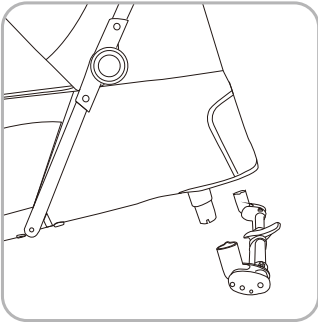

3. montieren und demontieren des Hinterrads Wie in der Abbildung gezeigt, setzen Sie zuerst den Hinterradbremssitz in den oberen Sitz des Hinterrads ein, und die Splitter des Radsitzes auf beiden Seiten werden herauspringen. Wenn die Demontage erforderlich ist, drücken Sie die Demontagetaste und ziehen Sie das Hinterrad heraus.

4. klappbarer Rahmen

Halten Sie im gebremsten Zustand den Lenker mit einer Hand fest, drücken Sie den Entriegelungsknopf am Lenkerrohr nach links, drücken Sie dann den Rahmenklappknopf, drücken Sie den Rahmen nach unten, und der Rahmen kann zusammengeklappt werden. Nachdem Sie den Rahmen zusammengeklappt haben, schließen Sie den Rahmenfalthaken.

5. use of rear wheel brake lever Drücken Sie das Bremspedal nach unten, die Bremse funktioniert. Umgekehrt kann sie auch gelöst werden.

6. für Sicherheitsgurte für Haustiere

AVVERTENZA: Tenere lontano dal fuoco

1. Si prega di leggere attentamente le presenti istruzioni prima dell'uso e di conservarle per future consultazioni. Se non si seguono queste istruzioni, la sicurezza degli animali domestici potrebbe essere compromessa.

2. Non lasciare andare la persona che assiste quando il prodotto è in uso.

3. Non utilizzare accessori non forniti dal produttore.

4. Qualsiasi carico attaccato alla maniglia influisce sulla stabilità del passeggino.

5. Assicurarsi che tutti i dispositivi di bloccaggio siano montati prima di utilizzare il passeggino.

6. Gli animali domestici devono essere trattenuti durante l'uso.

7. Non utilizzare il passeggino in zone impervie, vicino a stufe o altre aree pericolose.

8. Evitare l'uso o lo stoccaggio in ambienti umidi, freddi o ad alta temperatura e tenerlo lontano dal fuoco o da fonti di calore forte.

9. Non utilizzarlo per animali pericolosi, aggressivi e distruttivi.

Manutenzione e Cura

Controllare e mantenere frequentemente il passeggino per animali domestici. Il rivestimento in tessuto non può essere immerso in liquido e lavato. Quando si pulisce il rivestimento in tessuto, utilizzare una spazzola e altri strumenti di pulizia per pulire lo sporco.

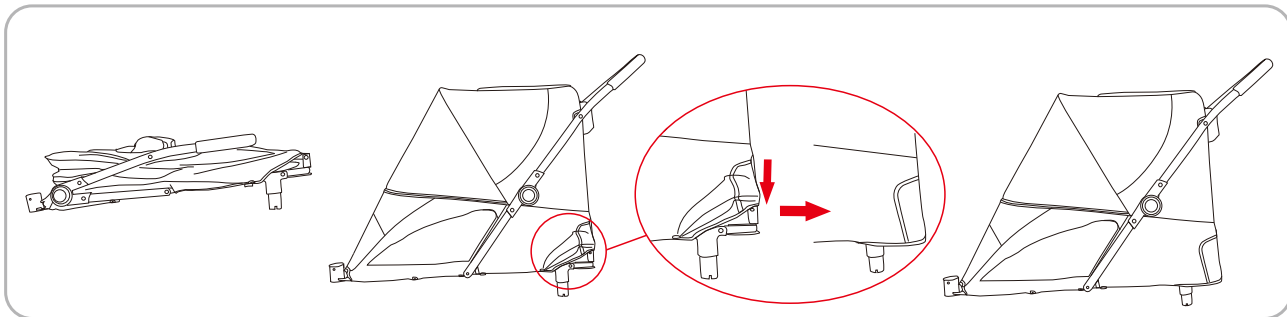
Parti di ricambio**Istruzioni per l'uso****1. Aprire il telaio**

Estrarre il telaio, tenere il manubrio con entrambe le mani e sollevarlo fino a quando non si sente uno scatto che indica che il telaio è completamente aperto. Dopo aver aperto il telaio, regolare la copertura laterale inferiore per renderla piatta.

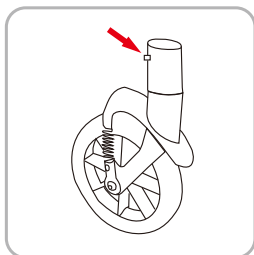
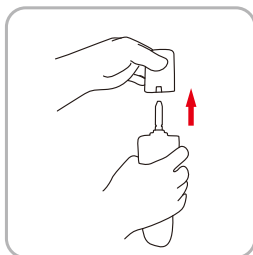
**2. Montaggio e smontaggio della ruota anteriore**

Come mostrato nella figura, inserire la ruota anteriore nel foro della sede superiore della ruota anteriore fino a sentire un "clic". Per lo smontaggio, premere il pulsante di smontaggio e tirarlo verso il basso.

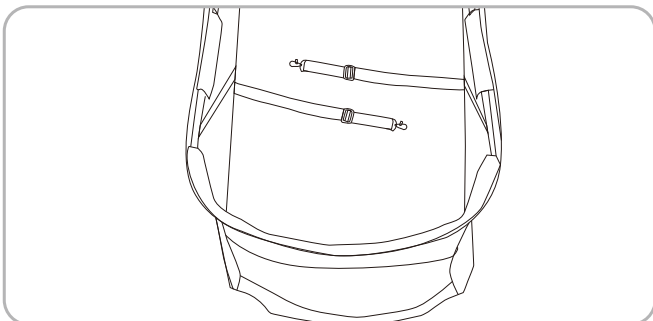
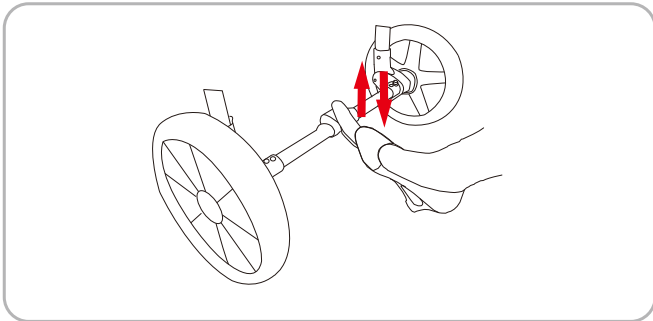
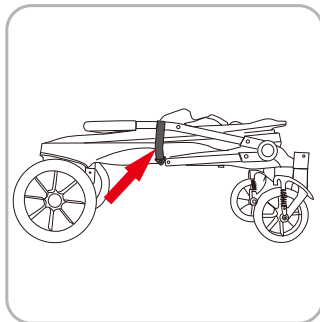
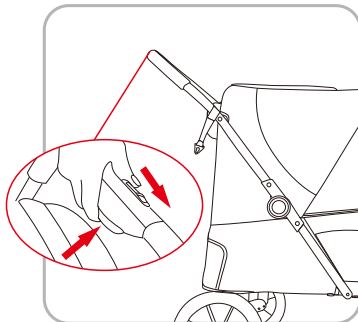
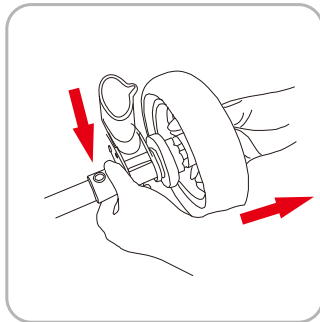
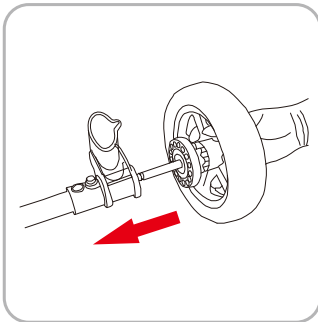
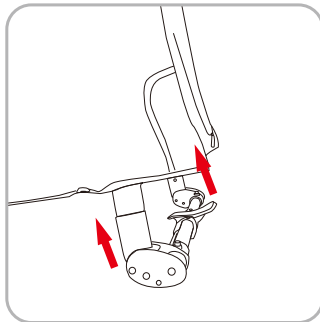
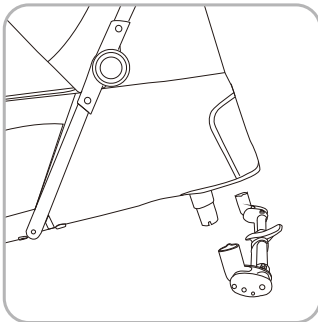

3. Montaggio e smontaggio della ruota posteriore Come mostrato nell'immagine, inserire prima la sede del freno della ruota posteriore nella sede superiore della ruota posteriore e le scegge della sede della ruota su entrambi i lati verranno fuori; quindi installare la ruota posteriore nel foro della sede della ruota posteriore fino a sentire un "clic".

Quando è necessario lo smontaggio, premere il pulsante di smontaggio ed estrarre la ruota posteriore.

4. Telaio pieghevole

In fase di frenata, tenere il manubrio con una mano, spingere il pulsante di sblocco sul tubo del manubrio verso sinistra, quindi premere il pulsante di ripiegamento del telaio, premere il telaio e il telaio può essere ripiegato. Dopo aver ripiegato il telaio, agganciare il gancio di ripiegamento del telaio.

5. Uso della leva del freno della ruota posteriore Premendo il pedale del freno, il freno funziona. Viceversa, può essere rilasciato.

6. Per le cinture di sicurezza degli animali domestici

AVERTISMENT: A se ține departe de foc

1. Vă rugăm să citiți cu atenție aceste instrucțiuni înainte de utilizare și să le păstrați în siguranță pentru consultare ulterioară. Nerespectarea acestor instrucțiuni poate afecta siguranța animalelor de companie.
2. Nu lăsați produsul nesupravegheat în timpul utilizării.
3. Nu utilizați accesorii care nu sunt furnizate de producător.
4. Orice sarcină atașată la mâner va afecta stabilitatea căruciorului pentru animale de companie.
5. Asigurați-vă că toate dispozitivele de blocare sunt montate înainte de a utiliza căruciorul pentru animale de companie.
6. Animalele de companie trebuie să fie asigurate cu centuri de siguranță în timpul utilizării.
7. Nu utilizați căruciorul pentru animale de companie pe teren accidentat, în apropierea sobelor sau a altor zone periculoase.
8. Evitați utilizarea sau depozitarea în medii umede, reci sau cu temperaturi ridicate și țineți-l departe de foc sau de surse puternice de căldură.
9. Nu îl utilizați pentru a transporta animale periculoase, agresive sau distructive.

Întreținere și îngrijire

Vă rugăm să verificați și să întrețineți frecvent căruciorul pentru animale de companie. Husa din țesătură nu poate fi înmuiată și spălată. Când curățați husa din țesătură, vă rugăm să folosiți o perie și alte instrumente de curățare pentru a îndepărta murdăria.

Piese

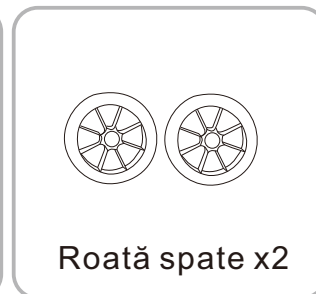
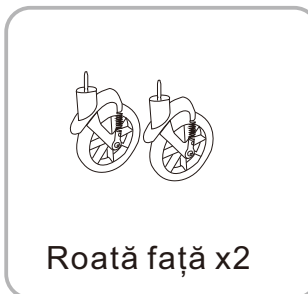
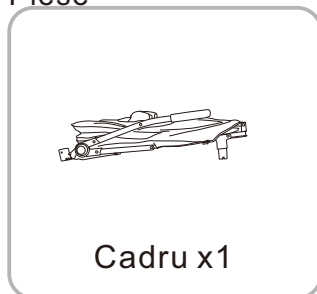

Instrucțiuni de utilizare

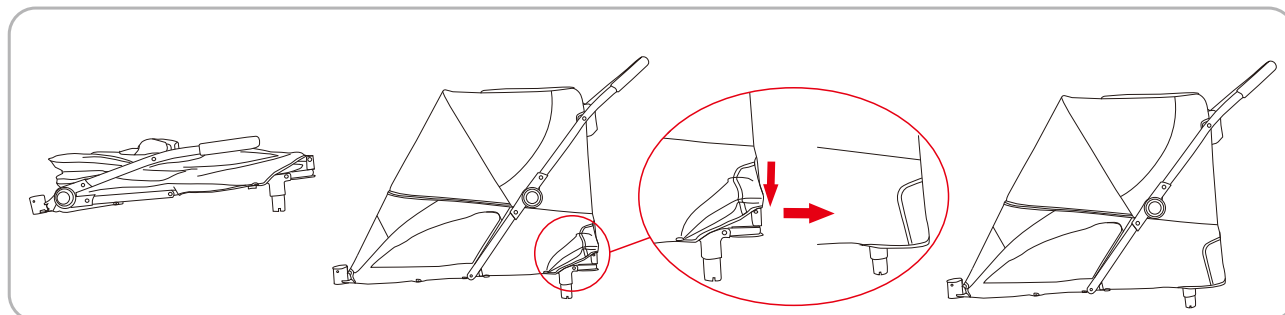

1. Deschiderea cadrului

Scoateți cadrul, țineți ghidonul cu ambele mâini și ridicați-l până când se aude un clic, ceea ce înseamnă că cadrul este complet deschis. După deschiderea cadrului, reglați capacul lateral inferior pentru a-l face plat.

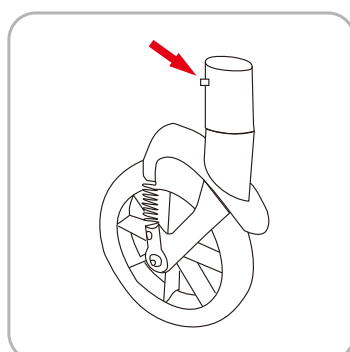
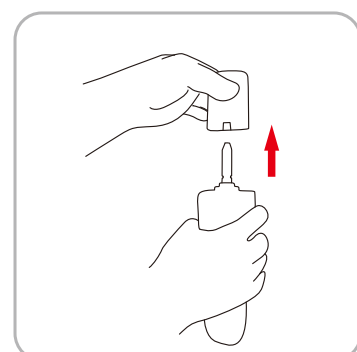

2. Montarea și demontarea roții din față. Așa cum se vede în imagine, introduceți roata din față în orificiul suportului superior al roții din față până când auziți un „clic”. Pentru a o demonta, apăsați butonul de demontare și trageți-o în jos.

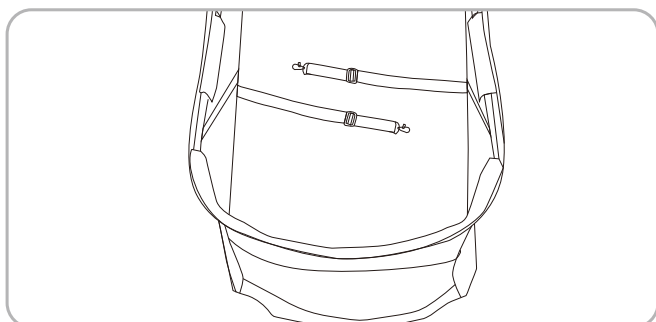
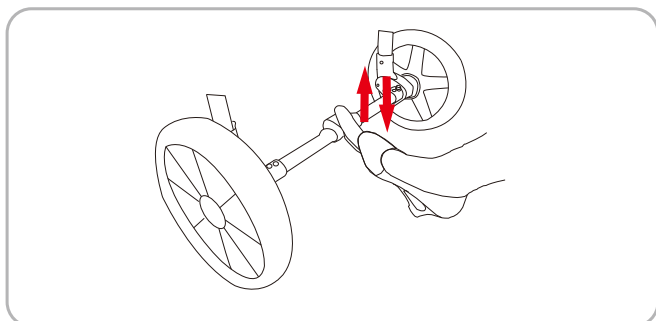
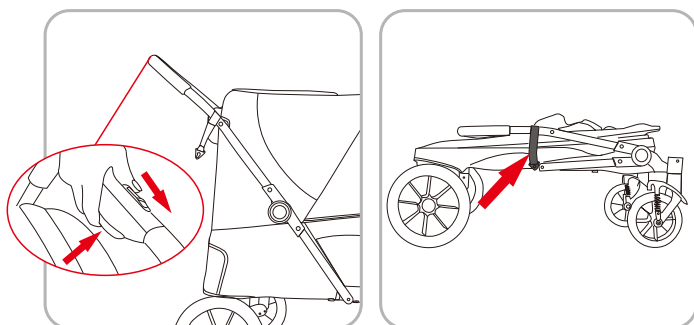
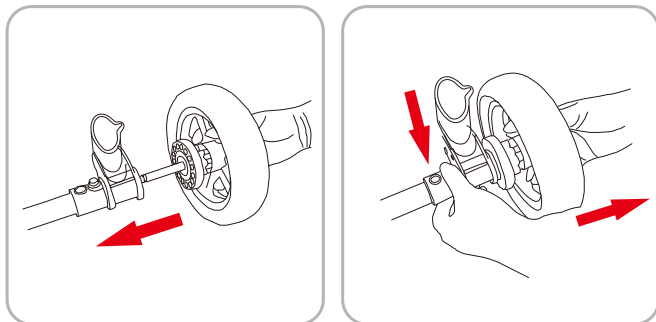
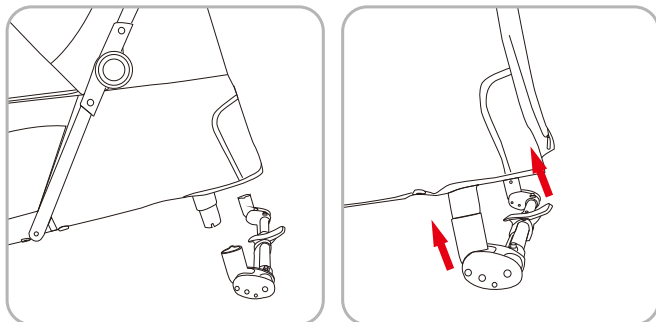

3. Montarea și demontarea roții din spate Așa cum se arată în imagine, introduceți mai întâi suportul frânei roții din spate în suportul superior al roții din spate, iar clemele de fixare de pe ambele părți ale suportului se vor elibera; apoi introduceți roata din spate în orificiul suportului până când auziți un „clic”.

Când este necesară demontarea, apăsați butonul de demontare și trageți roata din spate afară.

4. Plierea cadrului

Când roata este blocată, țineți ghidonul cu o mână, împingeți butonul de deblocare de pe tubul ghidonului spre stânga, apoi apăsați butonul de pliere a cadrului, apăsați cadrul în jos, iar cadrul se va plia. După plierea cadrului, fixați cârligul de pliere al cadrului.

5. Utilizarea manetei de frână a roții din spate Apăsați pedala de frână în jos, iar frâna se activează. În schimb, frâna poate fi eliberată.

6. Pentru centurile de siguranță ale animalelor de companie

If you have any questions, please contact our customer care center, Our contact details are below:

US

 001-877-644-9366

 customerservice@aosom.com

Imported by Aosom LLC
7777 Center Ave. Suite 430
Huntington Beach, CA 92647-9998 USA
MADE IN CHINA

If you have any questions, please contact our customer care center, Our contact details are below:

CA

 416-792-6088

 customerservice@aosom.ca

Imported by Aosom Canada Inc.
Unit 33-1 Sparks Avenue, North York, Ontario,
Canada
M2H 2W1
MADE IN CHINA

Si vous avez la moindre question, veuillez contacter notre centre d'assistance à la clientèle, Nos coordonnées sont les suivantes:

 416-792-6088

 customerservice@aosom.ca

Importé par Aosom Canada Inc.
Unité 33-1 Sparks Avenue, North York, Ontario,
Canada M2H 2W1
Fabriqué en Chine

Si tiene alguna pregunta, comuníquese con nuestro Centro de Atención al Cliente, Nuestros datos de contacto son los siguientes:

ES

 0034-931294512

 atencioncliente@aosom.es

IMPORTADOR/Fabricante/REP:
SPANISH AOSOM, S.L.
C/ROC GROS, Nº15.08550, ELS HOSTALET DE
BALENYÀ, SPAIN.
B66295775
HECHO EN CHINA

Se tiver alguma dúvida, por favor contacte o nosso Centro de Atendimento ao Cliente, Os nossos dados de contacto são os seguintes:

 0034-931294512

 info@aosom.pt.

Si vous avez la moindre question, veuillez contacter notre centre d'assistance à la clientèle, Nos coordonnées sont les suivantes:

FR

 0033-1-84166106

 aosom@mhfrance.fr

Importé par/Fabricant/REP:
MH FRANCE
2 Rue Maurice Hartmann
92130 Issy Les Moulineaux
France
FABRIQUÉ EN CHINE



FR

**DONNEZ
OU
RECYCLEZ**



ASSOCIATION

OU



LIVRAISON

OU



DÉCHÈTERIE

Adresses sur quefairedemesdechets.fr

If you have any questions, please contact our customer care center, Our contact details are below:

UK

 0044-800-240-4004

 enquiries@mhstar.co.uk

IMPORTER ADDRESS:
MH STAR UK LTD
1 Northampton Cross Logistics Park
Northampton Cross Road
Northampton
Nn4 9FH
Tel: 0800 240 4050
enquiries@mhstar.co.uk
MADE IN CHINA

Wenn Sie Fragen haben, wenden Sie sich bitte an unser Kundendienstzentrum, Unsere Kontaktdaten stehen unten:

DE

 0049-0(40)-87408465

 service@aosom.de

ADRESSE DES IMPORTEURE/Hersteller/REP:
MH Handel GmbH
Wendenstraße 309
D-20537 Hamburg
Germany
IN CHINA HERGESTELLT

In caso di dubbio, si prega di contattare il nostro centro assistenza clienti, I nostri dettagli di contatto sono di seguito:

IT

 0039-0249471447

 clienti@aosom.it

IMPORTATO DA/Produttore/REP:
AOSOM Italy srl
Centro Direzionale Milanofiori
Strada 1 Palazzo F1
20057 Assago (MI)
P.I.: 08567220960
FATTO IN CINA

Importator/Producător/REP:

RO

Aosom Romania SRL
Str. Barbu Mumuleanu, nr. 30-32
Bucuresti, Sector 2
Tel: +40 312294730
clienti@aosom.ro
Fabricat in China