



IN241000599V01

84H-263V00

EN_ IMPORTANT, RETAIN FOR FUTURE REFERENCE: READ CAREFULLY.

FR_ IMPORTANT: A LIRE ATTENTIVEMENT ET À CONSERVER POUR CONSULTATION ULTÉRIEURE.

ES_ IMPORTANTE, LEA Y GUARDE PARA FUTURAS REFERENCIAS.

PT_ IMPORTANTE: LEIA ATENTAMENTE E GUARDE PARA CONSULTA FUTURA.

DE_ WICHTIG! SORGFÄLTIG LESEN UND FÜR SPÄTER NACHSCHLAGEN AUFBEWAHREN.

IT_ IMPORTANTE! CONSERVARE IL PRESENTE MANUALE PER FUTURO RIFERIMENTO E LEGGERLO ATTENTAMENTE.

RO_ IMPORTANT: CITIȚI CU ATENȚIE ȘI PĂSTRAȚI PENTRU CONSULTARE VIITOARE.

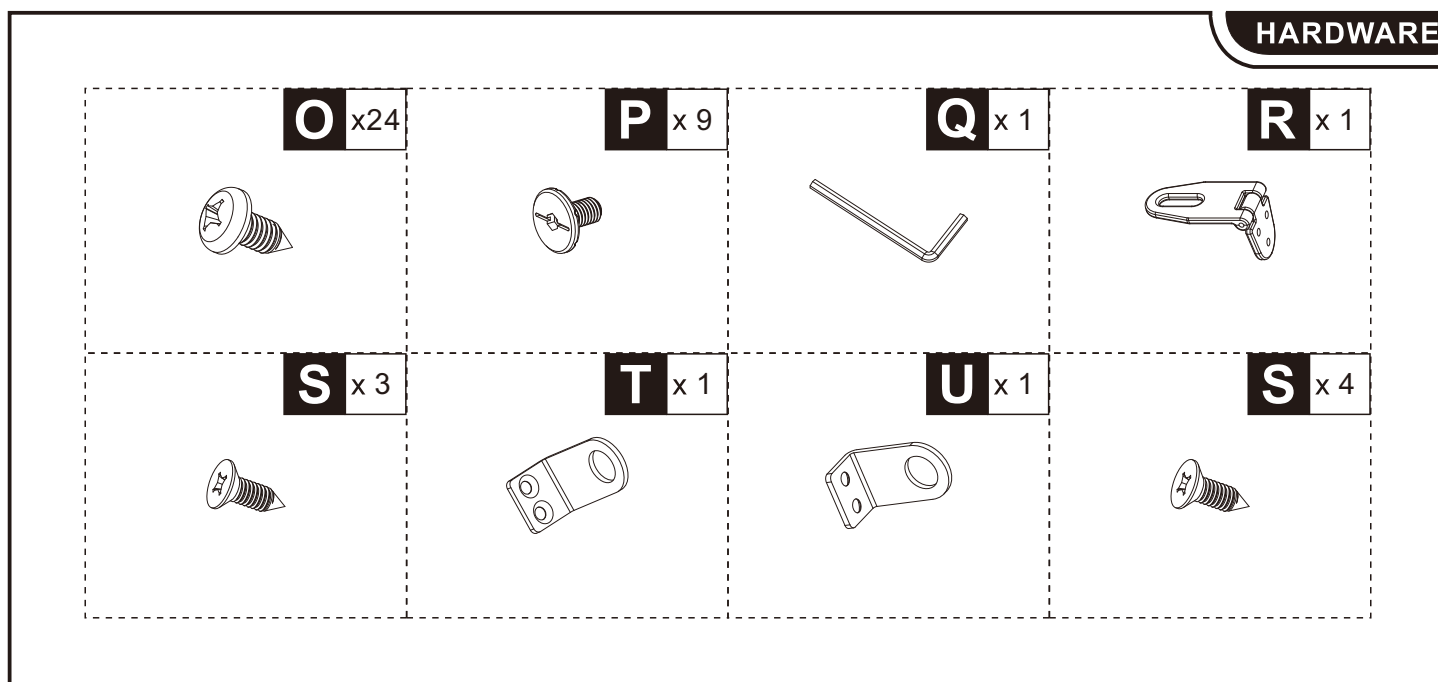
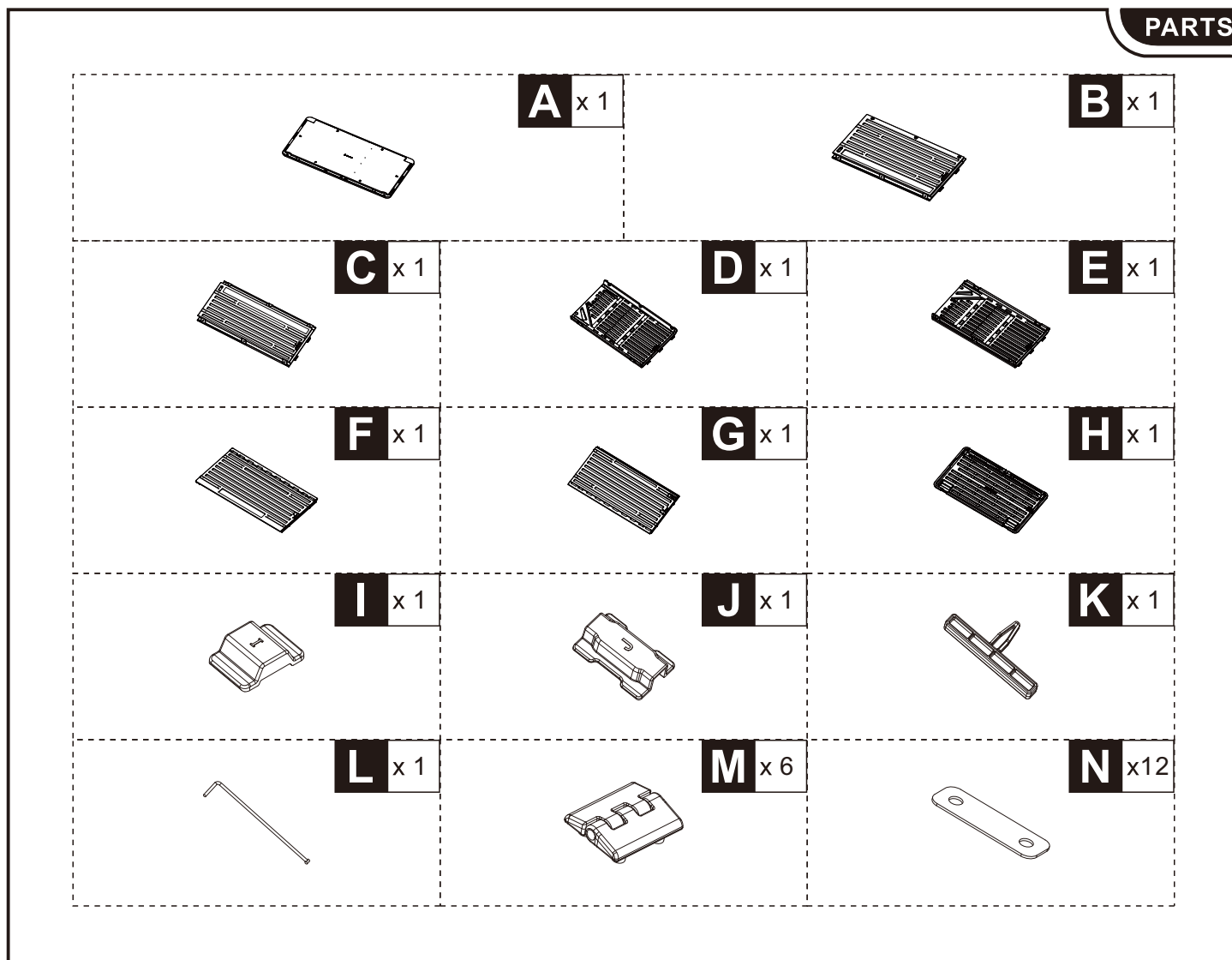

EN_ Do not tighten bolts fully until all parts are connected!

FR_ Ne serrez pas les boulons à fond tant que toutes les pièces ne sont pas connectées!

ES_ No apriete los tornillos completamente hasta que todas las partes están conectadas!

PT_ Não apertar completamente os parafusos até que todas as peças estejam encaixadas!

DE_ Ziehen Sie die Schrauben erst fest an, wenn alle Teile verbunden sind!

IT_ Non serrare completamente i bulloni fino a tutte le parti non sono ancora collegate!

RÖ_ Nu strângeți complet șuruburile până când toate piesele nu sunt conectate!



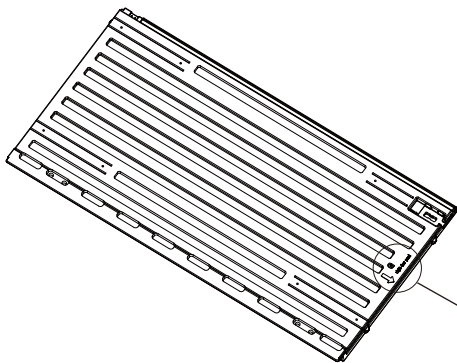
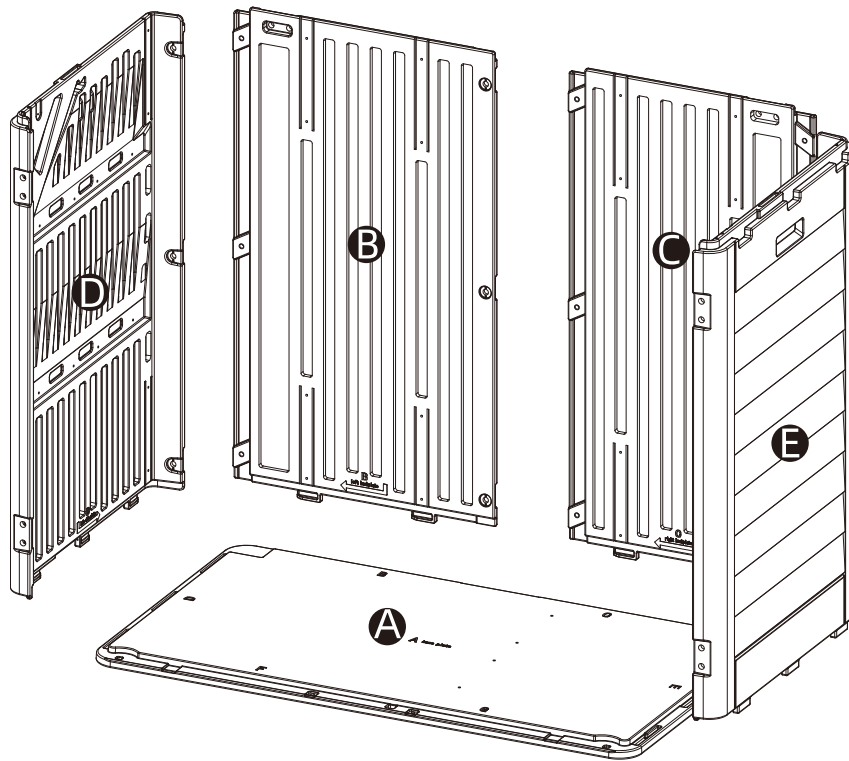
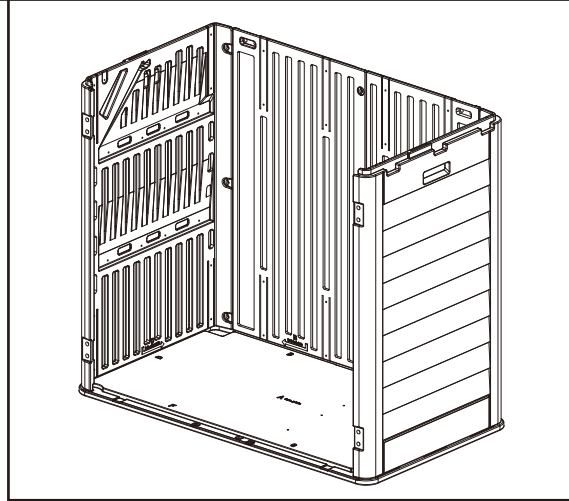

Top1

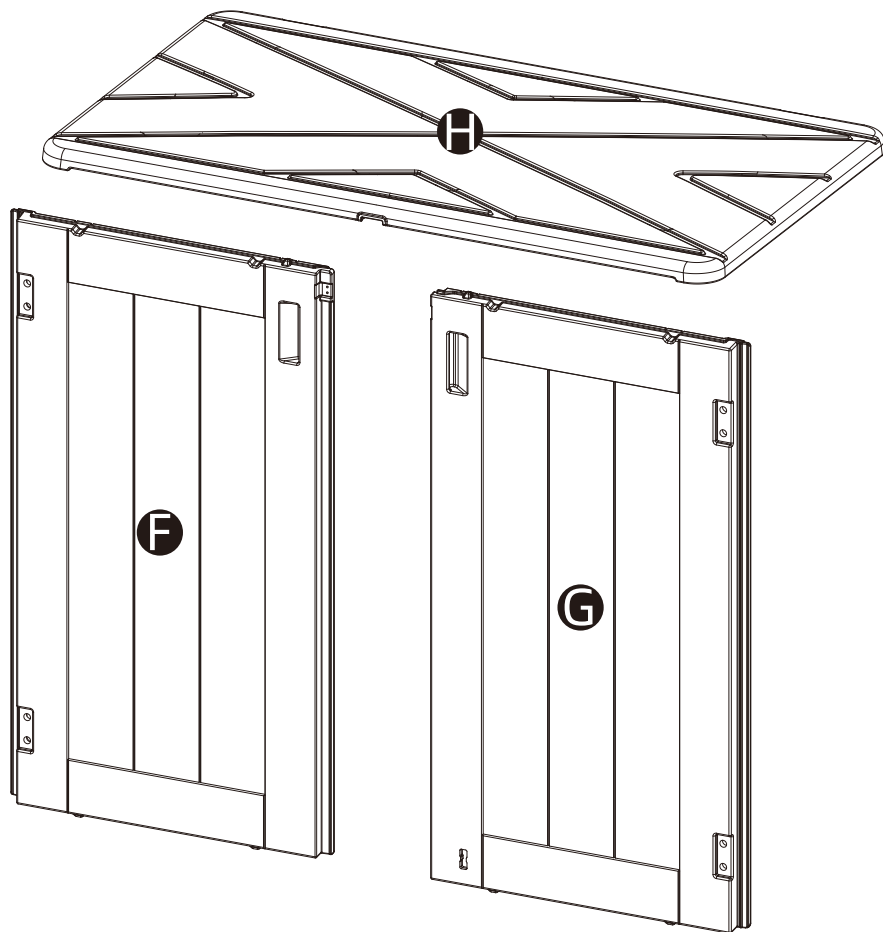

*EN*_position of codes
*FR*_position des codes
*ES*_posición de los códigos
*PT*_posição dos códigos
*DE*_Position der Codes
*IT*_posizione dei codici
*RO*_poziția codurilor

Top2



- | | | | | | |
|---|---|----|---|---|----|
| B |  | x1 | C |  | x1 |
| P |  | x3 | Q |  | x1 |

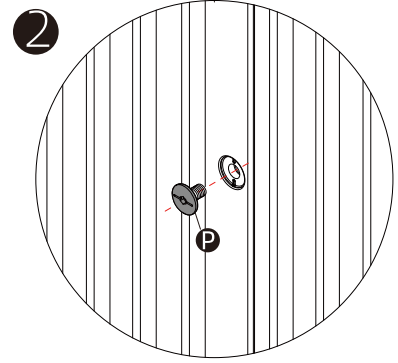
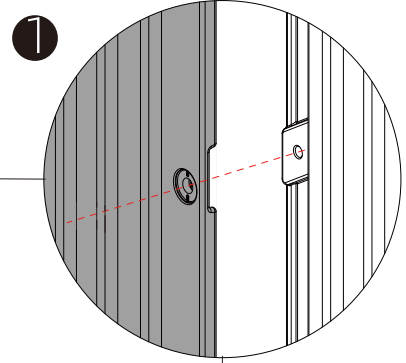
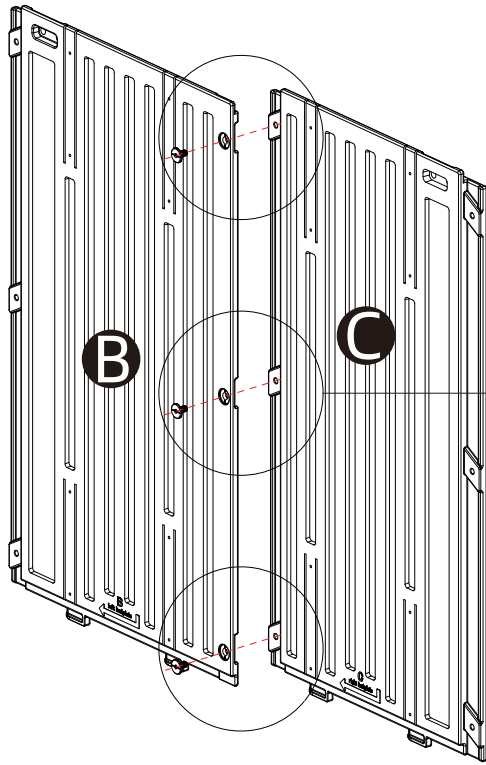

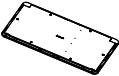
- | | | |
|---|---|----|
| A |  | x1 |
|---|---|----|

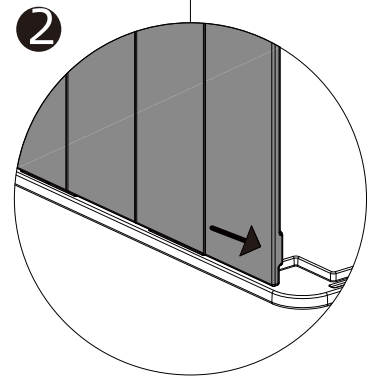
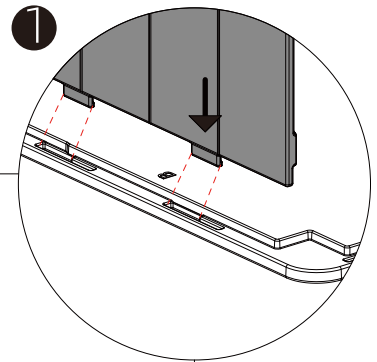
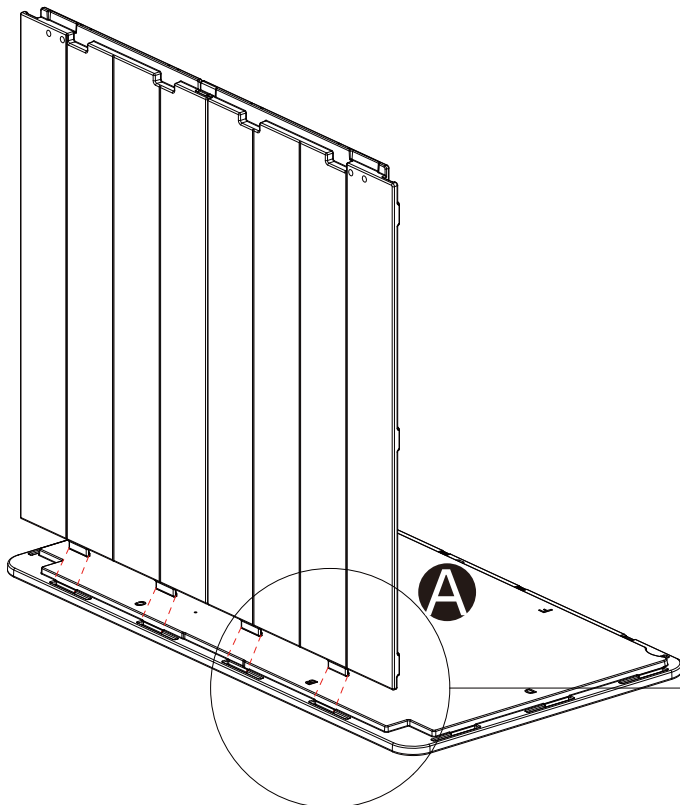

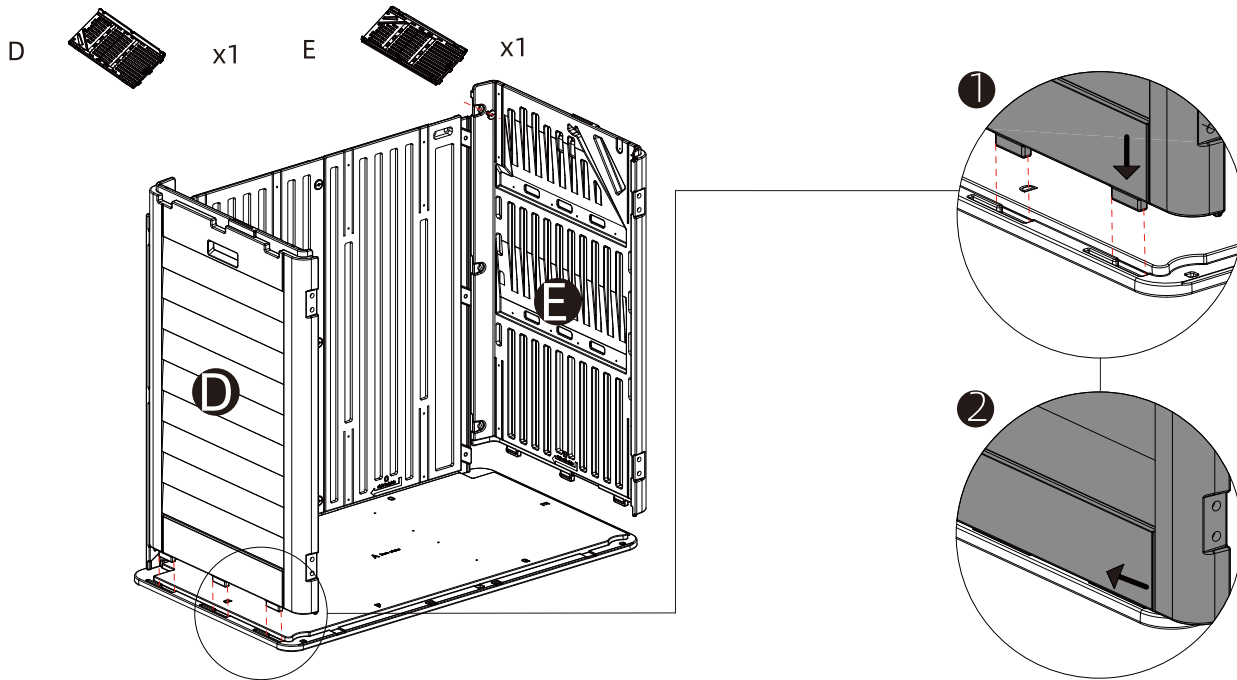

EN_Note: Insert the side panels into the bottom first.

Secondly push the S side panels in the direction of arrow.

Ensure that the panels are tilted 10 degrees to the outside to pass the bump smoothly

FR_Remarque : Insérez d'abord les panneaux latéraux dans le fond.

Poussez ensuite les panneaux latéraux S dans le sens de la flèche.

Veillez à ce que les panneaux soient inclinés de 10 degrés vers l'extérieur pour passer la bosse en douceur.

ES_Nota: Inserte primero los paneles laterales en la parte inferior.

En segundo lugar, empuje los paneles laterales S en la dirección de la flecha.

Asegúrese de que los paneles estén inclinados 10 grados hacia el exterior para que pasen suavemente por el tope.

PT_Nota: Insira primeiro os painéis laterais na parte inferior.

Em segundo lugar, empurre os painéis laterais S na direção da seta.

Certifique-se de que os painéis estão inclinados 10 graus para o exterior para passarem suavemente pelo ressalto

DE_Hinweis: Setzen Sie zuerst die Seitenteile in den Boden ein.

Schieben Sie anschließend die S-Seitenteile in Pfeilrichtung.

Vergewissern Sie sich, dass die Platten um 10 Grad nach außen geneigt sind, um die Beule reibungslos passieren zu können.

IT_Nota: inserire prima i pannelli laterali nella parte inferiore.

In secondo luogo, spingere i pannelli laterali S nella direzione della freccia.





Assicurarsi che i pannelli siano inclinati di 10 gradi verso l'esterno per passare agevolmente l'urto.

RO_Notă: Introduceți mai întâi panourile laterale în partea de jos.

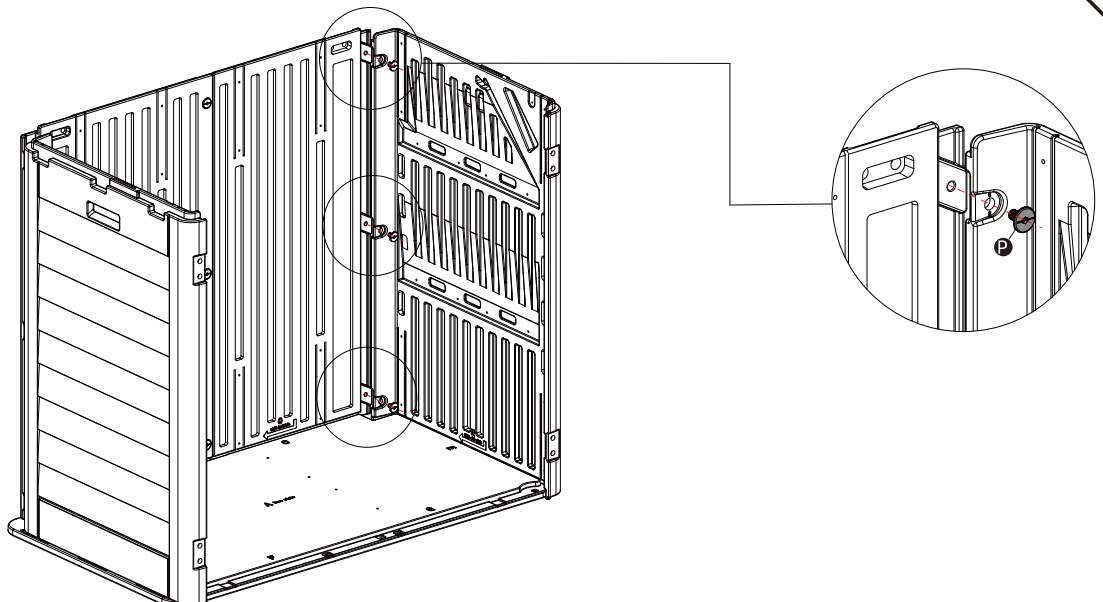
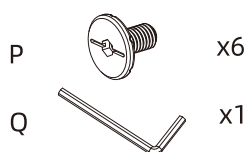

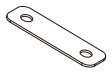
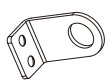

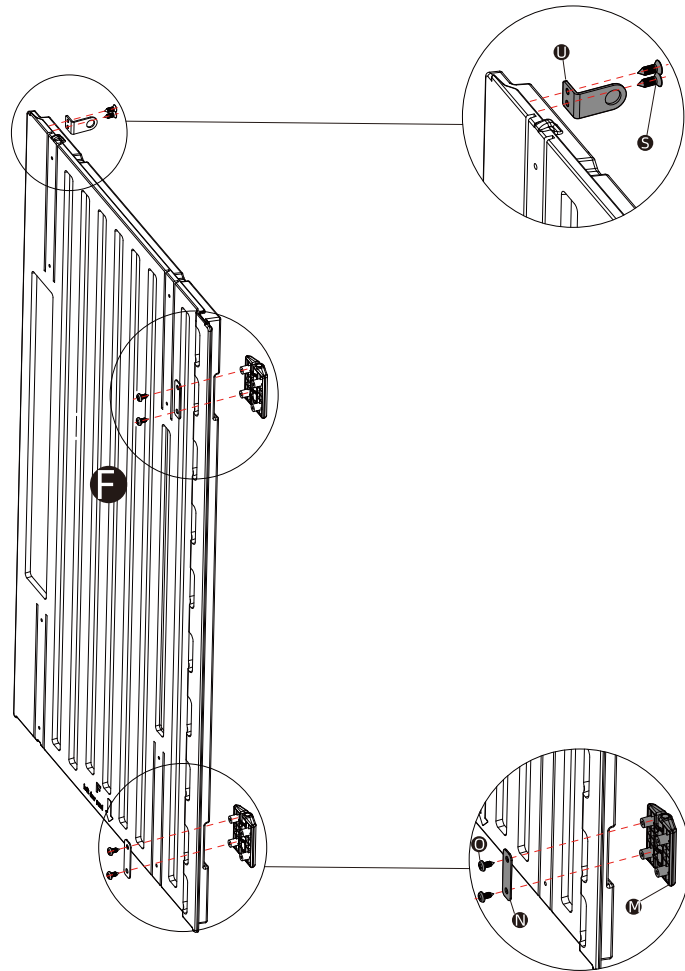

Apoi împingeți panourile laterale S în direcția indicată de săgeată.

Asigurați-vă că panourile sunt înclinate cu 10 grade spre exterior pentru a trece fără probleme peste denivelare

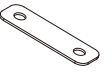
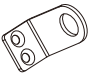

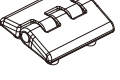
- F  x1
- N  x2
- U  x1
- M  x2
- O  x4
- S  x2





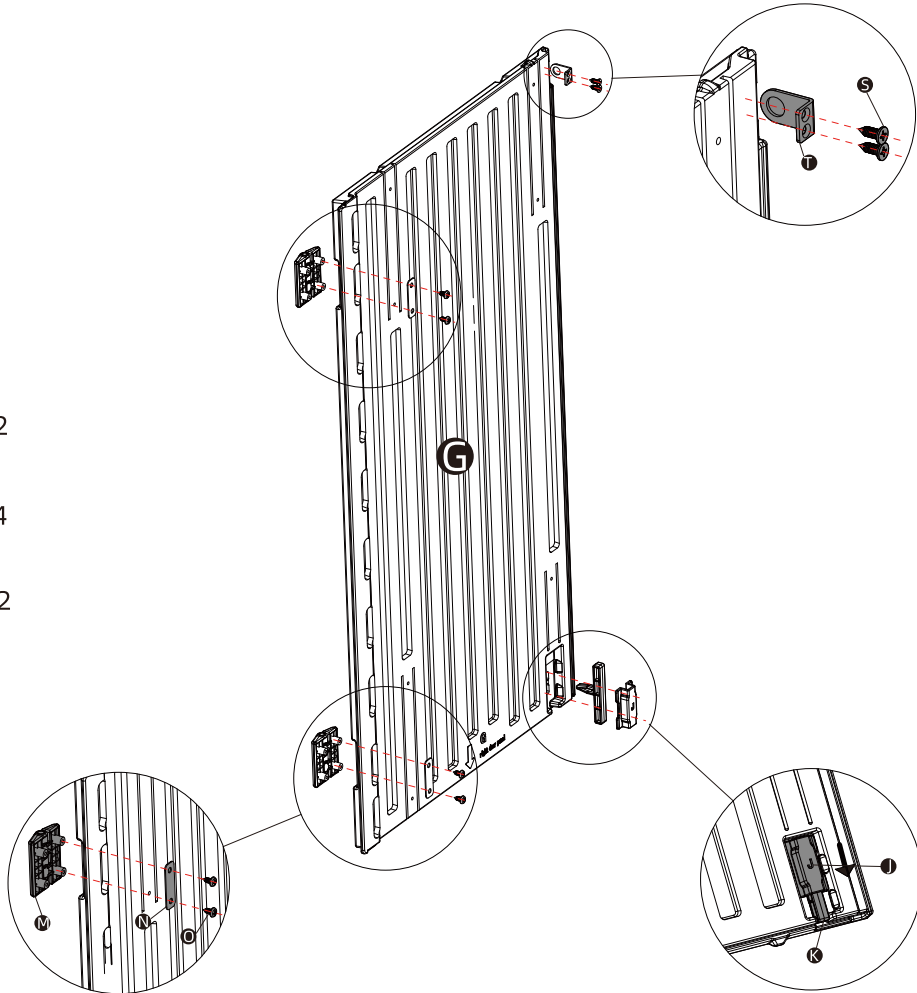

- G  x1
- N  x2
- T  x1
- J  x1
- M  x2
- O  x4
- S  x2
- K  x1

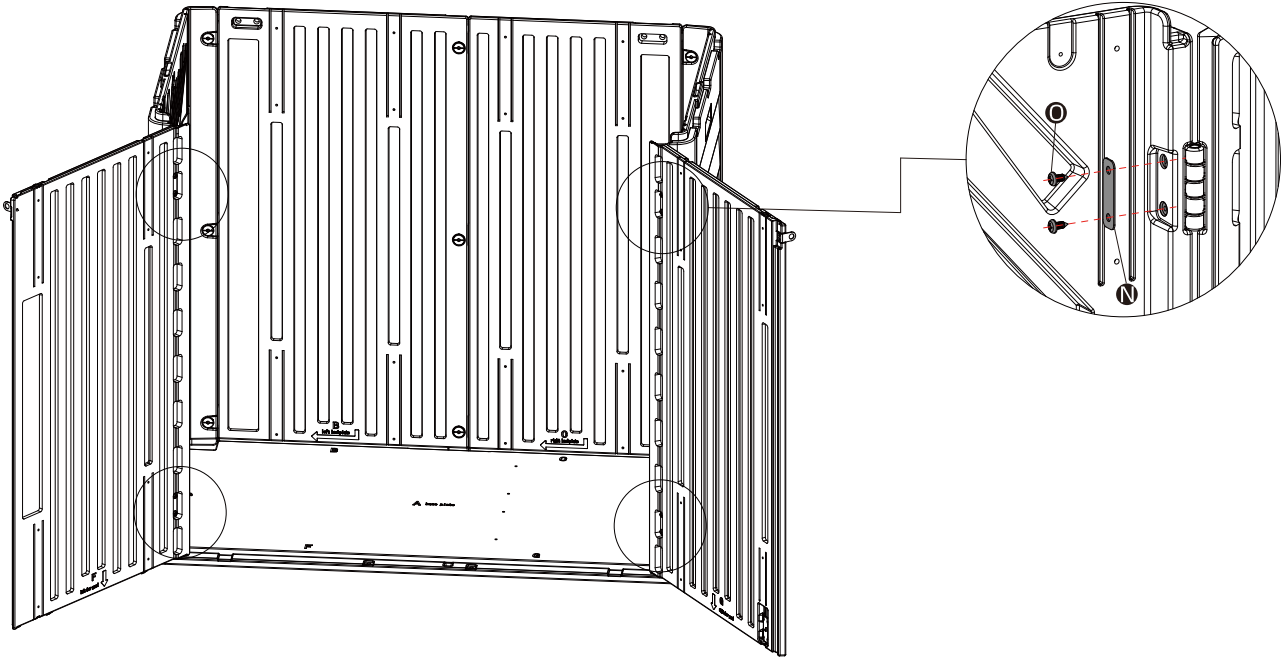

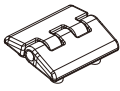
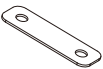
- N  x4 O  x8

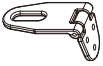

- H  x1 M  x2
 N  x2 O  x4
 R  x1 S  x3

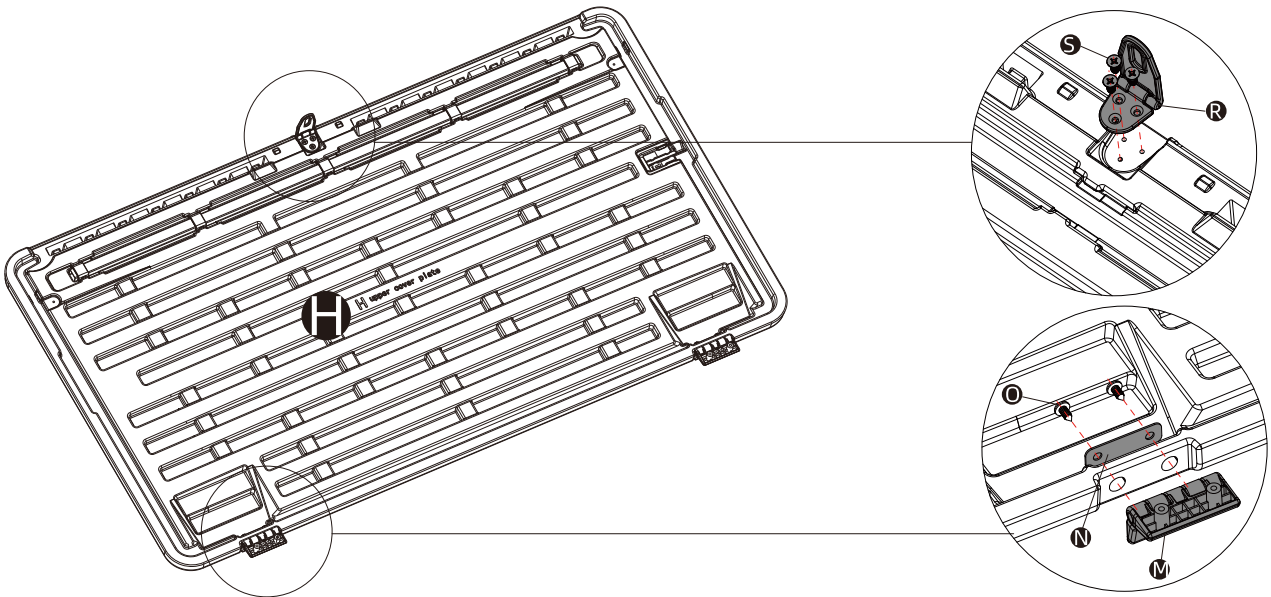

- L x1
N x2
I x1
O x4
-

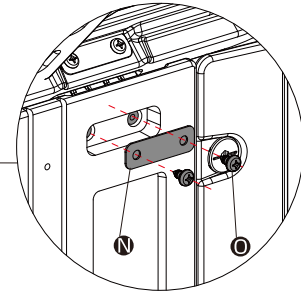
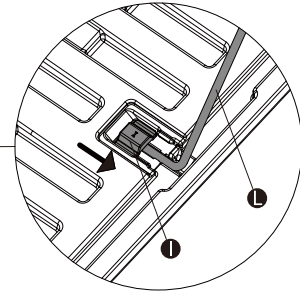
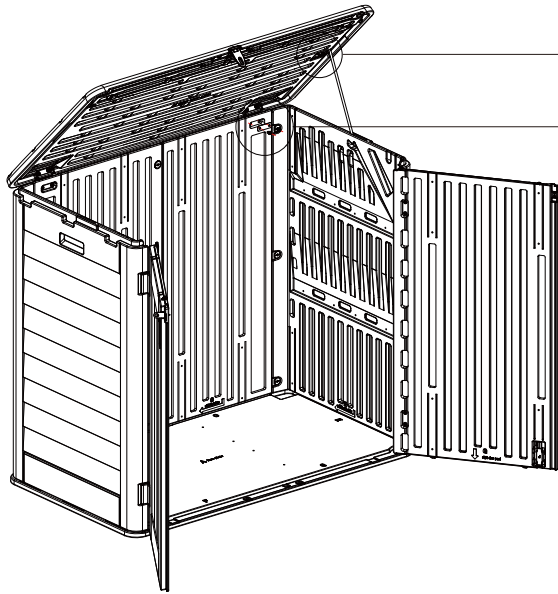

EN Put the arm support(L) into the groove, and fix it by clip(I).

FR Placer le support de bras (L) dans la rainure et le fixer à l'aide du clip (I).

ES Coloque el soporte del brazo (L) en la ranura y fijelo con el clip (I).

PT Colocar o suporte do braço(L) na ranhura e fixá-lo com o grampo(I).

DE Setzen Sie die Armstütze (L) in die Nut ein und befestigen Sie sie mit dem Clip (I).

IT Inserire il supporto del braccio (L) nella scanalatura e fissarlo con la clip (I).

RO Introduceți suportul pentru braț (L) în canelură și fixați-l cu clema (I).



EN Lock the arm in the direction of the arrow
FR Verrouiller le bras dans le sens de la flèche
ES Bloquee el brazo en la dirección de la flecha
PT Bloquear o braço na direção da seta
DE Verriegeln Sie den Arm in Pfeilrichtung
IT Bloccare il braccio in direzione della freccia
RO Blocați brațul în direcția indicată de săgeată

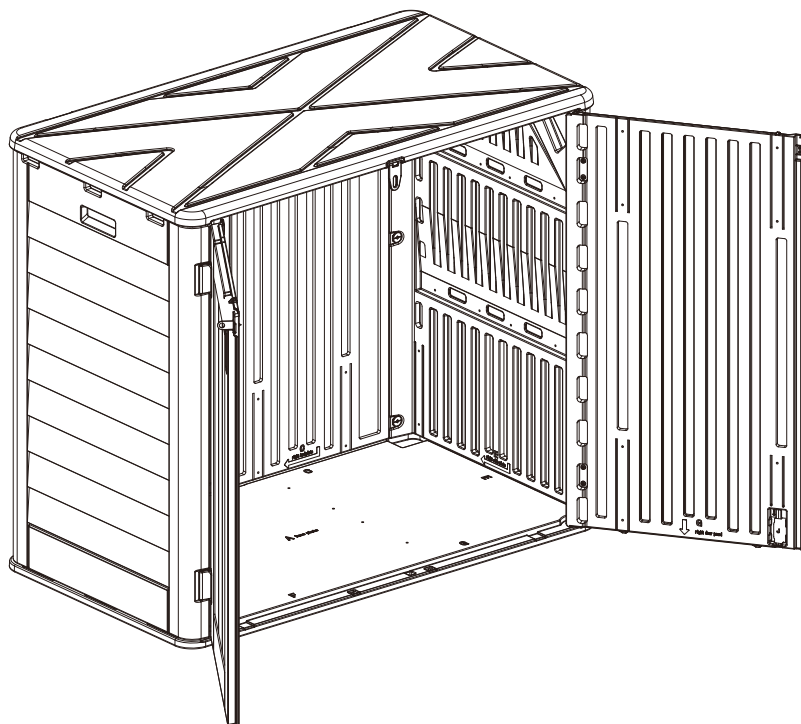
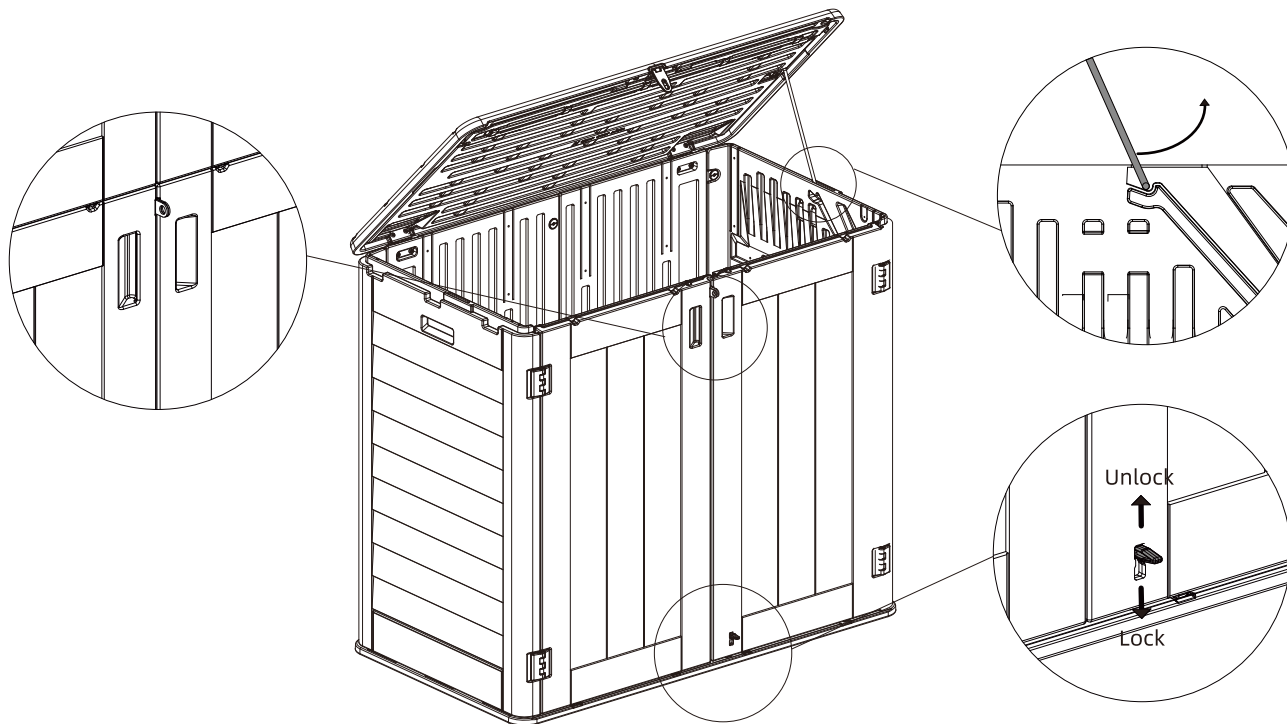

If you have any questions, please contact our customer care center, Our contact details are below:

US

 001-877-644-9366

 customerservice@aosom.com

Imported by Aosom LLC
7777 Center Ave. Suite 430
Huntington Beach, CA 92647-9998 USA
MADE IN CHINA

If you have any questions, please contact our customer care center, Our contact details are below:

UK

 0044-800-240-4004

 enquiries@mhstar.co.uk

IMPORTER ADDRESS:
MH STAR UK LTD
1 Northampton Cross Logistics Park
Northampton Cross Road
Northampton
Nn4 9FH
Tel: 0800 240 4050
enquiries@mhstar.co.uk
MADE IN CHINA

If you have any questions, please contact our customer care center, Our contact details are below:

CA

 416-792-6088

 customerservice@aosom.ca

Imported by Aosom Canada Inc.
Unit 33-1 Sparks Avenue, North York, Ontario,
Canada
M2H 2W1
MADE IN CHINA

Si vous avez la moindre question, veuillez contacter notre centre d'assistance à la clientèle, Nos coordonnées sont les suivantes:

 416-792-6088

 customerservice@aosom.ca

Importé par Aosom Canada Inc.
Unité 33-1 Sparks Avenue, North York, Ontario,
Canada M2H 2W1
Fabriqué en Chine

Wenn Sie Fragen haben, wenden Sie sich bitte an unser Kundendienstzentrum, Unsere Kontaktdaten stehen unten:

DE

 0049-0(40)-87408465

 service@aosom.de

ADRESSE DES IMPORTEURE/Hersteller/REP:
MH Handel GmbH
Wendenstraße 309
D-20537 Hamburg
Germany
IN CHINA HERGESTELLT

In caso di dubbio, si prega di contattare il nostro centro assistenza clienti, I nostri dettagli di contatto sono di seguito:

IT

 0039-0249471447

 clienti@aosom.it

IMPORTATO DA/Produttore/REP:
AOSOM Italy srl
Centro Direzionale Milanofiori
Strada 1 Palazzo F1
20057 Assago (MI)
P.I.: 08567220960
FATTO IN CINA

Si tiene alguna pregunta, comuníquese con nuestro Centro de Atención al Cliente, Nuestros datos de contacto son los siguientes:

ES

 0034-931294512

 atencioncliente@aosom.es

IMPORTADOR/Fabricante/REP:
SPANISH AOSOM, S.L.
C/ROC GROS, Nº15.08550, ELS HOSTALET DE
BALENYÀ, SPAIN.
B66295775
HECHO EN CHINA

Se tiver alguma dúvida, por favor contacte o nosso Centro de Atendimento ao Cliente, Os nossos dados de contacto são os seguintes:

 0034-931294512

 info@aosom.pt.

Importator/Producător/REP:

RO

Aosom Romania SRL
Str. Barbu Mumuleanu, nr. 30-32
Bucuresti, Sector 2
Tel: +40 312294730
clienti@aosom.ro
Fabricat in China

Si vous avez la moindre question, veuillez contacter notre centre d'assistance à la clientèle, Nos coordonnées sont les suivantes:

FR

 0033-1-84166106

 aosom@mhfrance.fr

Importé par/Fabricant/REP:
MH FRANCE
2 Rue Maurice Hartmann
92130 Issy Les Moulineaux
France
FABRIQUÉ EN CHINE



FR

**DONNEZ
OU
RECYCLEZ**



ASSOCIATION

OU



LIVRAISON

OU



DÉCHÈTERIE

Adresses sur quefairedemesdechets.fr