

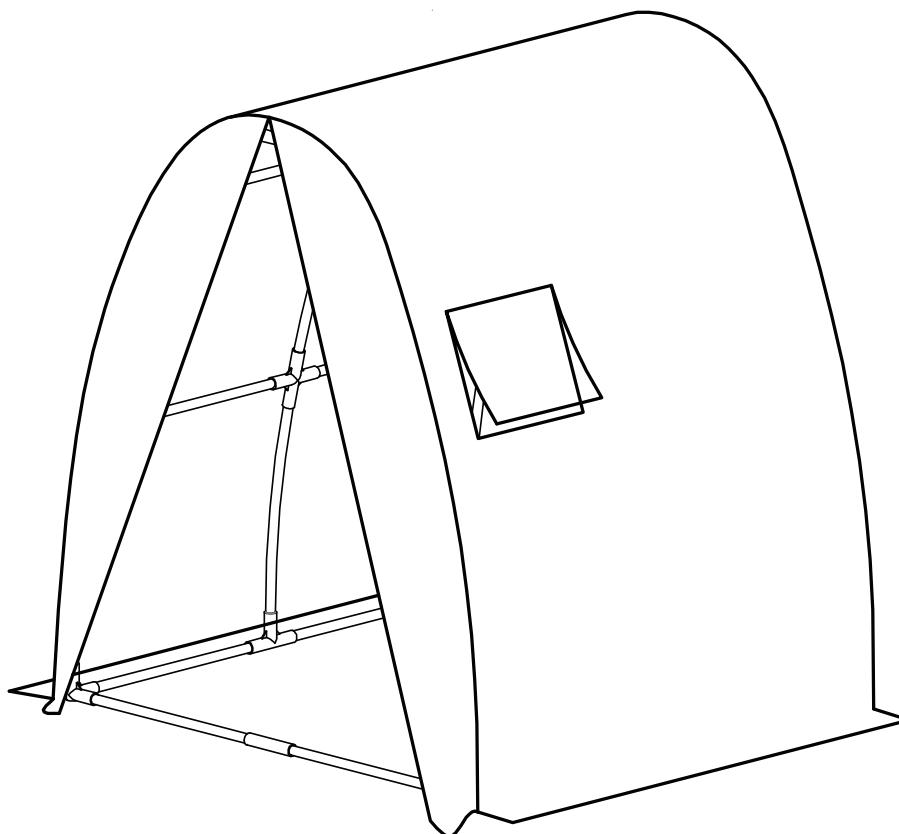

IN241000295V02\_GL

**84H-247V00\_84H-247V01**



**EN** Must be dismantled in severe weather.  
**FR** Doit être démonté par mauvais temps.  
**ES** Debe desmontarse en caso de mal tiempo.  
**PT** Deve ser desmontado em caso de mau tempo.  
**DE** Bei Unwetter muss abgebaut werden.  
**IT** Deve essere smontato in caso di maltempo.  
**PL** Należy zdemontować podczas złej pogody.  
**RO** Trebuie demontat în caz de vreme rea.

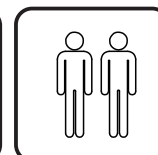
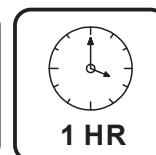

**EN IMPORTANT, RETAIN FOR FUTURE REFERENCE: READ CAREFULLY.**

**FR IMPORTANT : A LIRE ATTENTIVEMEN ET A CONSERVER POUR VOUS Y REFERER ULTERIEUREMENT**

**ES IMPORTANTE, LEA Y GUARDE PARA FUTURAS REFERENCIAS.**

**PT IMPORTANTE, RETAR PARA REFERÊNCIA FUTURA: LEIA ATENTAMENTE.**

**DE WICHTIG! SORGFÄLTIG LESEN UND FÜR SPÄTER NACHSCHLAGEN AUFBEWAHREN.**

**IT IMPORTANTE! CONSERVARE IL PRESENTE MANUALE PER FUTURO RIFERIMENTO E LEGGERLO ATTENTAMENTE.**

**RO IMPORTANT, PĂSTRAȚI PENTRU REFERINȚĂ VIITOARE: CITIȚI CU ATENȚIE.**

**PL WAŻNE, PRZECHOWAJ DO WYKORZYSTANIA W PRZYSZŁOŚCI: PRZECZYTAJ UWAŻNIE.**

**1** x18

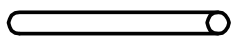

87CM

**2** x6



43.5CM

**3** x12



92CM

**4** x1



**5** x4

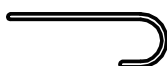

**6** x4



**A** x4

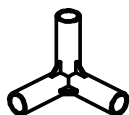

**B** x12

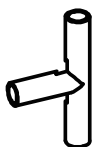

**C** x5

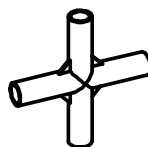

**K** x2

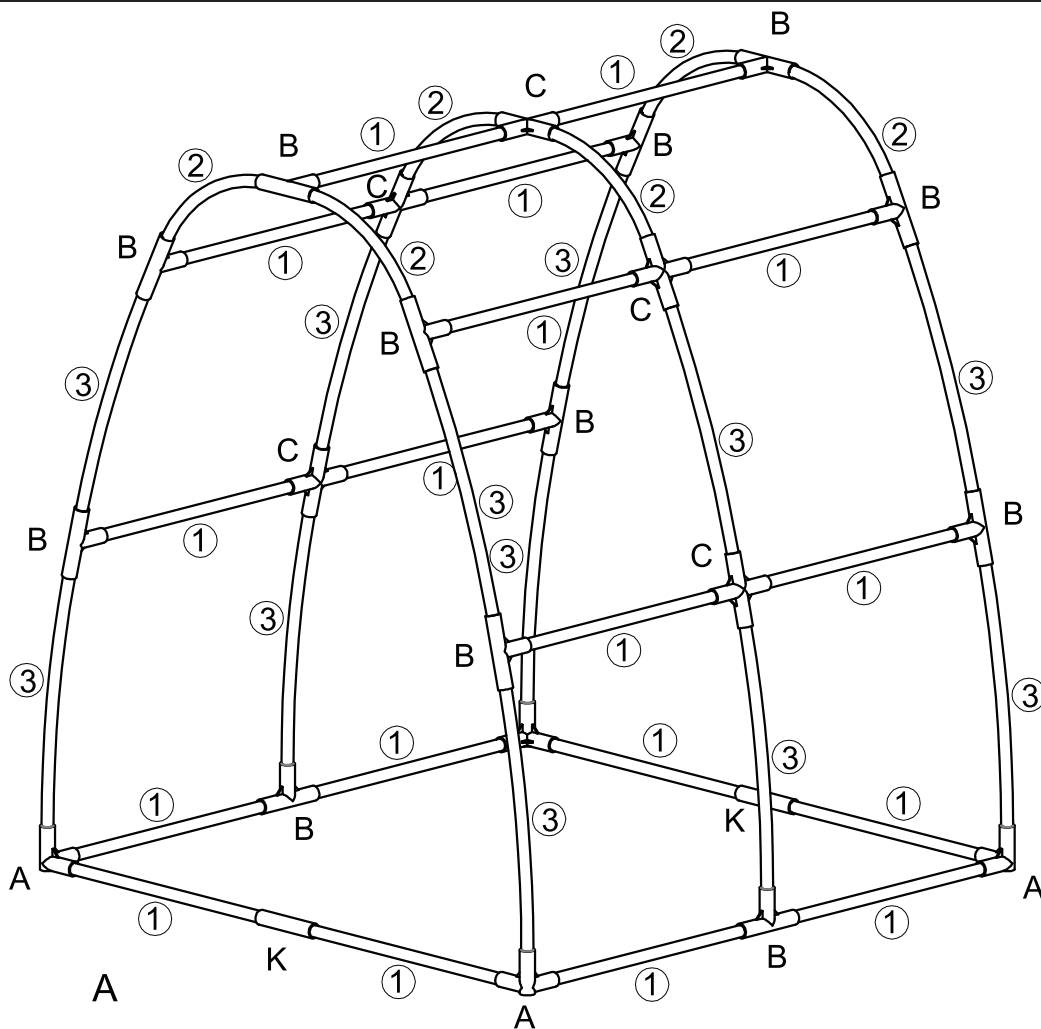

# Step1

Ax4

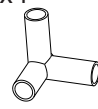

Kx2

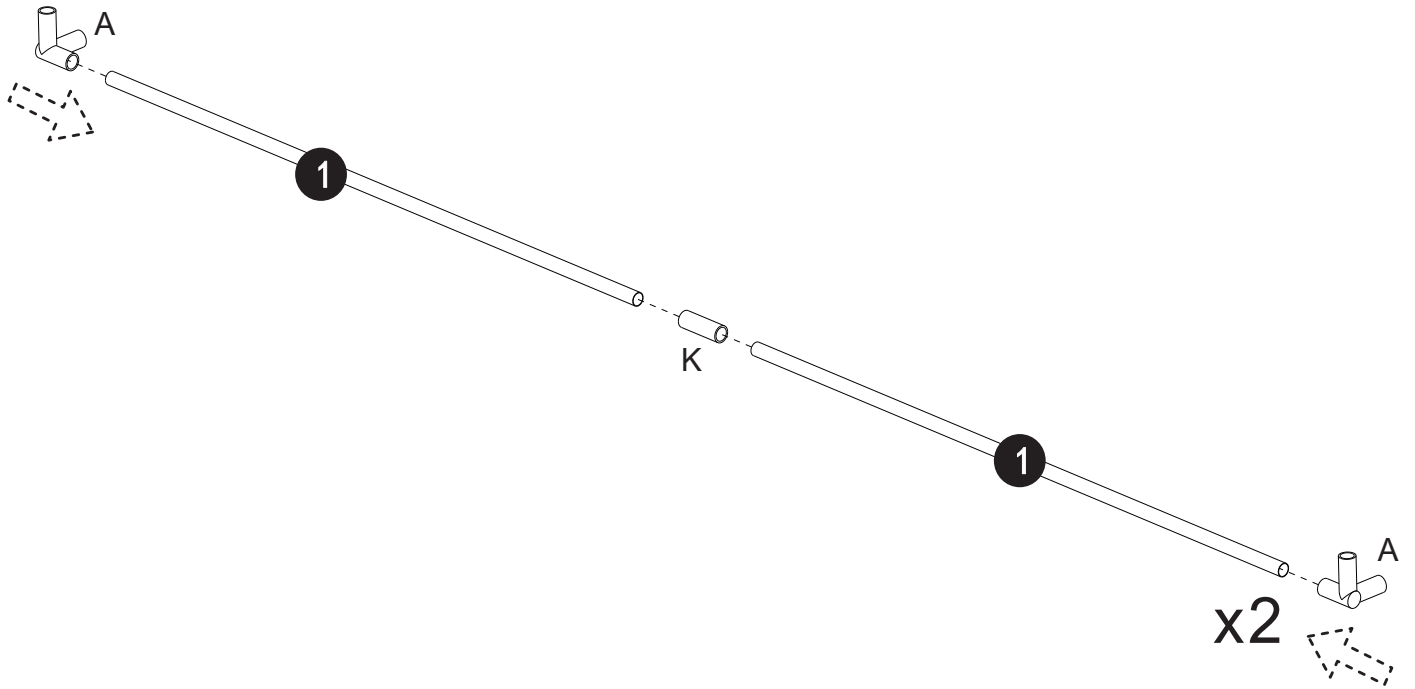

# Step2

Bx2

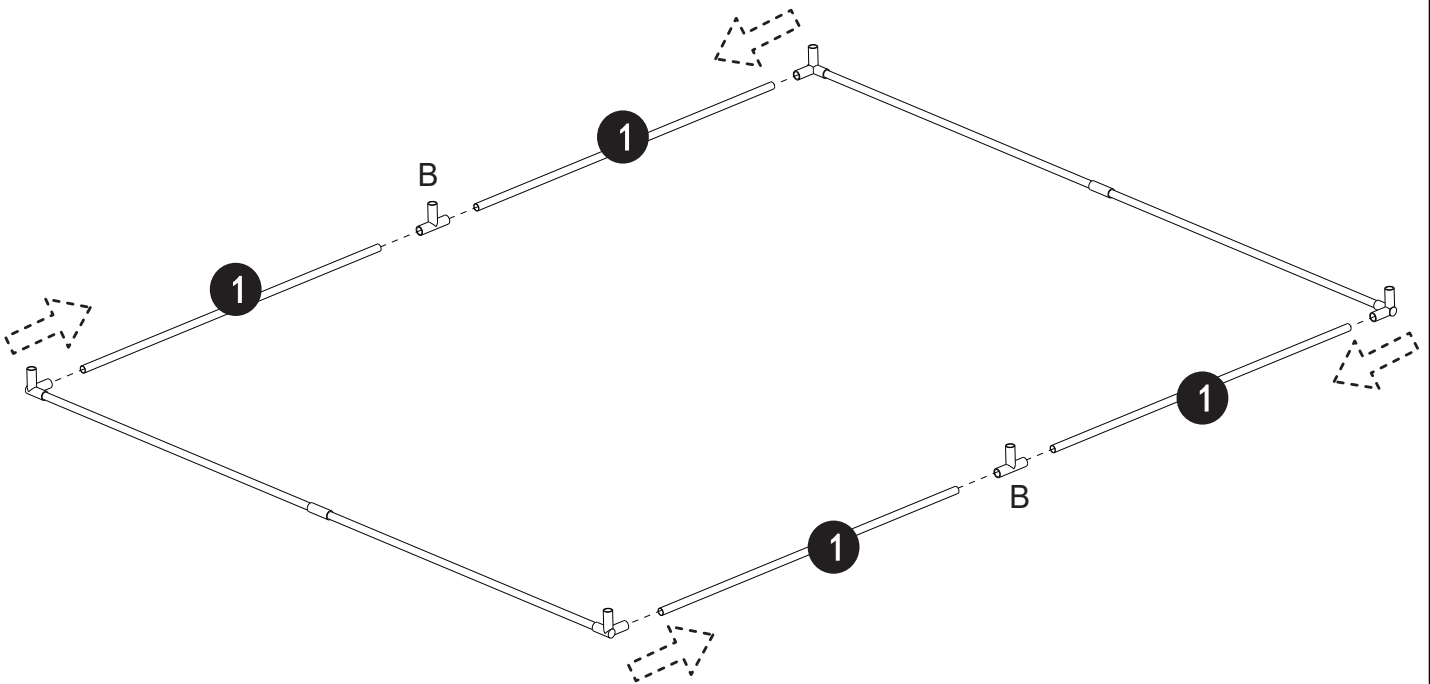
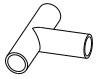

# Step3

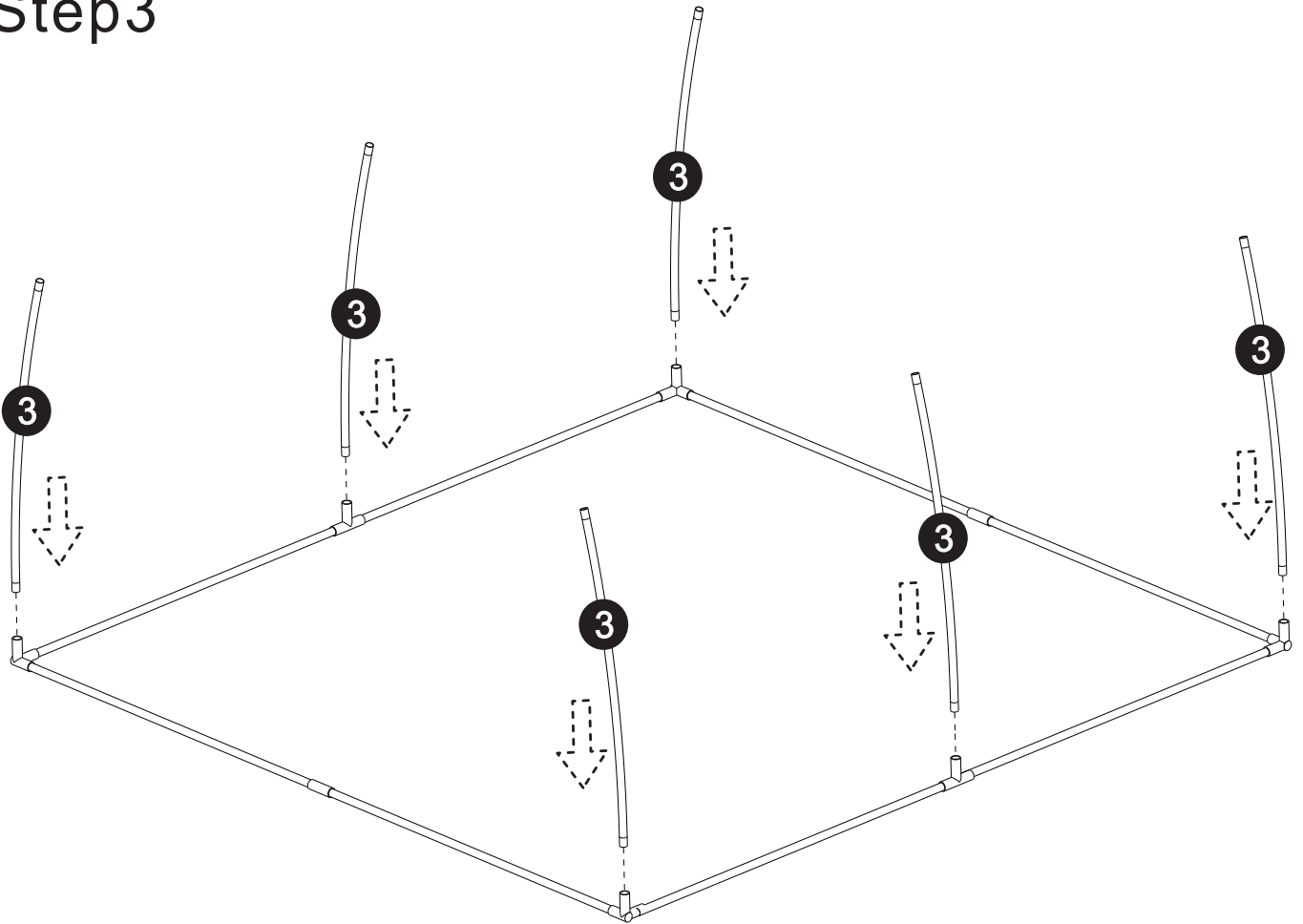

# Step4

Bx10



Cx5

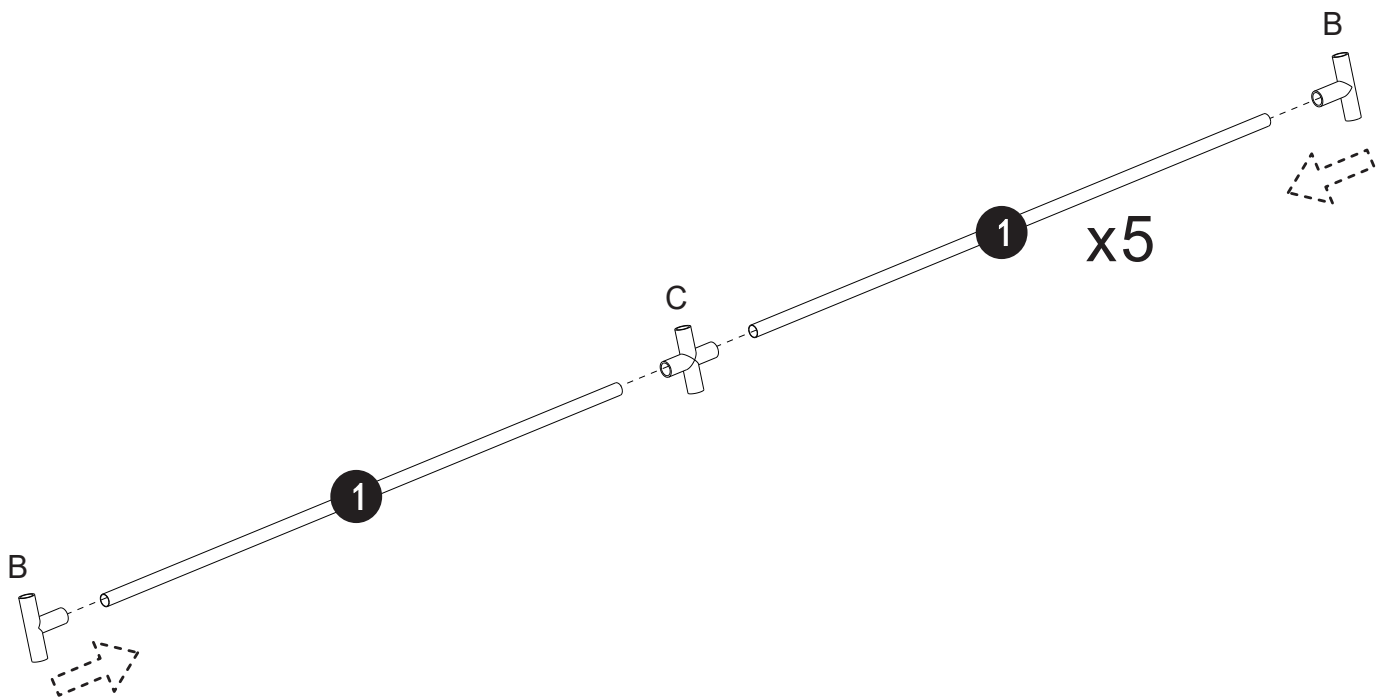
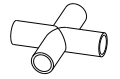

# Step5

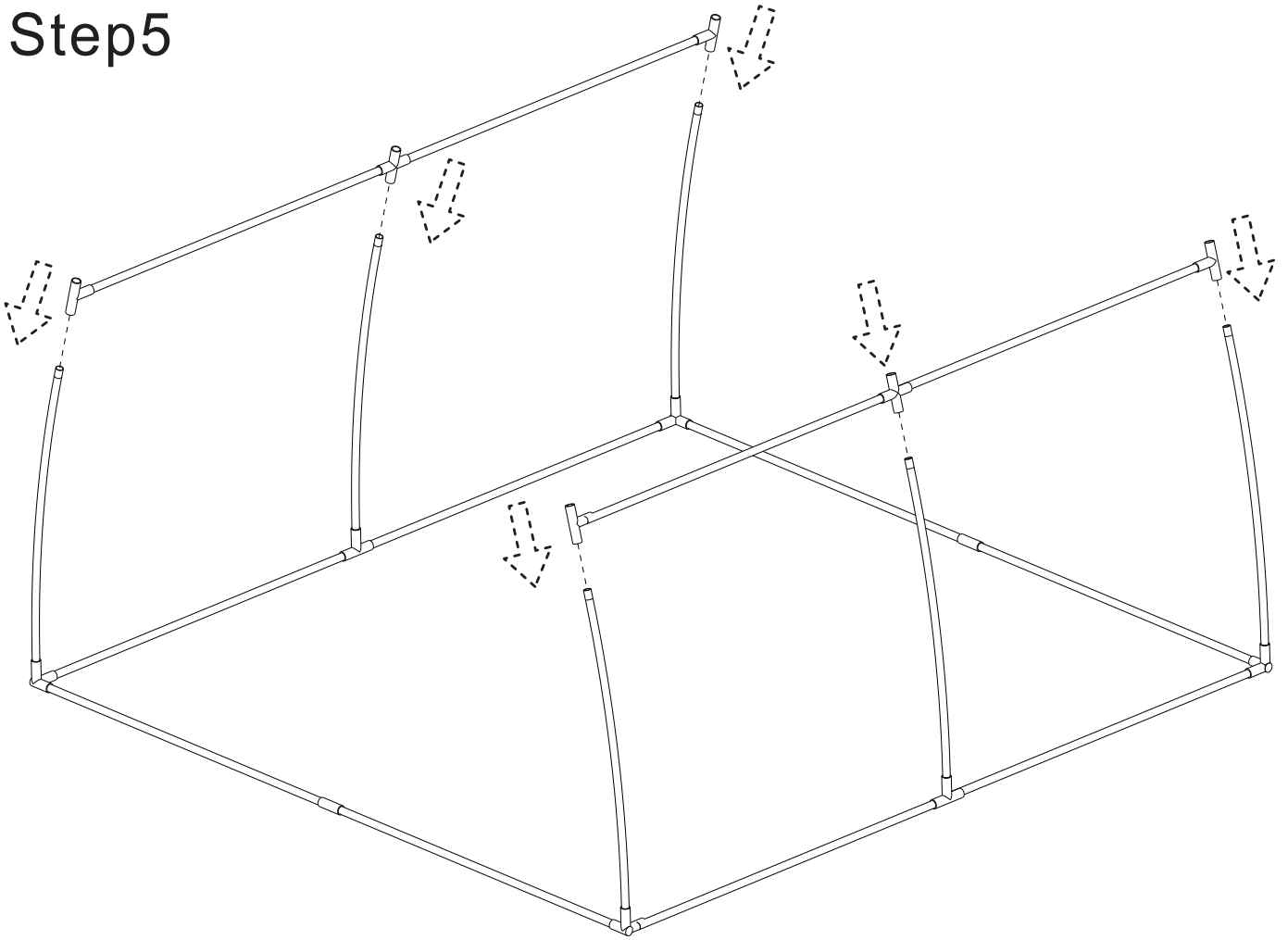

# Step6

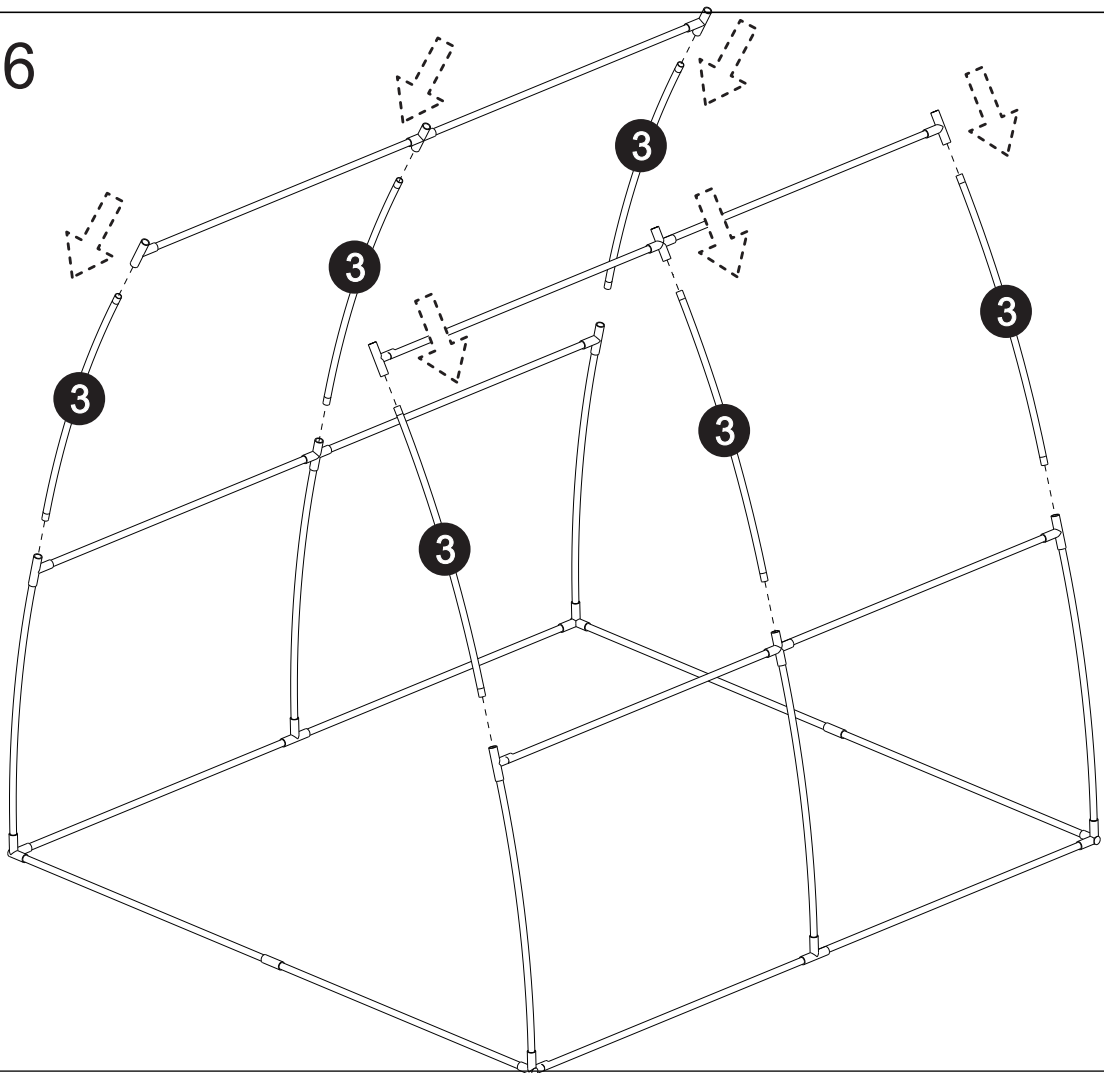

# Step 7

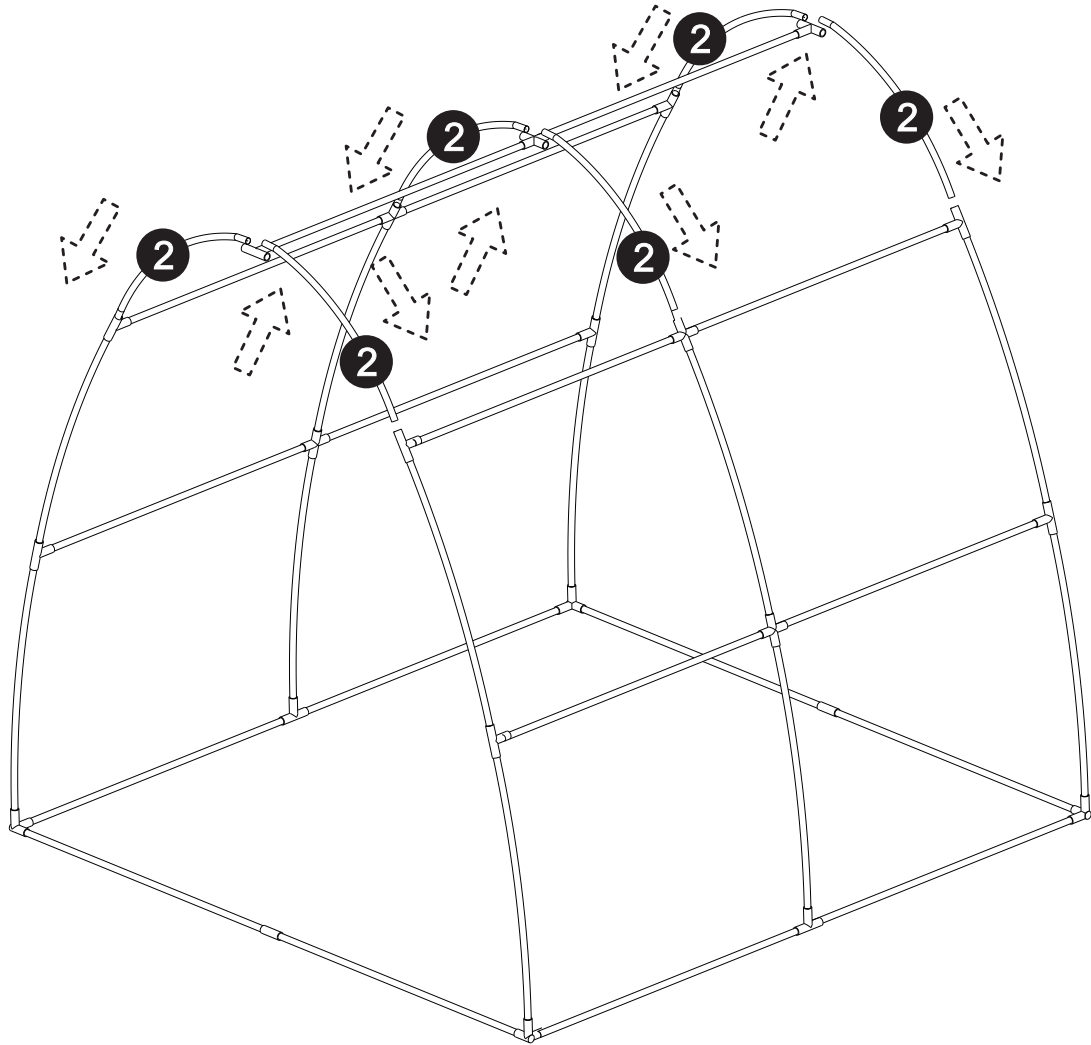

## Step 8

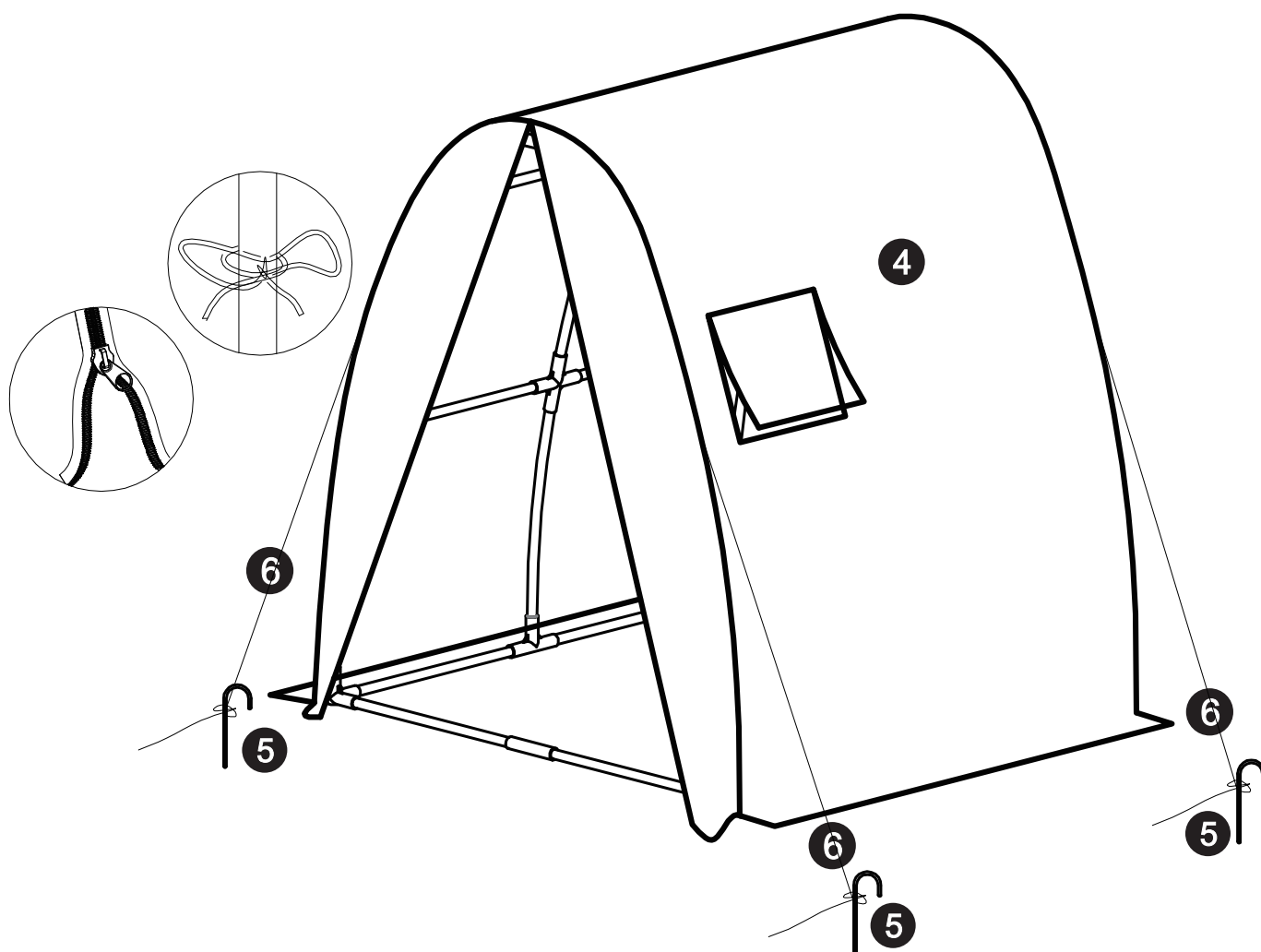

**EN** If there is a zipper on the cover, please open the zipper before proceeding with the external installation to avoid pulling and tearing.

**FR** Si la housse est munie d'une fermeture éclair, veuillez l'ouvrir avant de procéder à l'installation externe pour éviter de tirer et de déchirer.

**DE** Wenn der Überzug einen Reißverschluss hat, öffnen Sie diesen bitte, bevor Sie mit der Außenmontage fortfahren, um ein Ziehen und Reißen zu vermeiden.

**ES** Si la funda tiene una cremallera, ábrala antes de proceder con la instalación exterior para evitar tirones y desgarros.

**PT** Se a capa tiver um zíper, abra-o antes de prosseguir com a instalação externa para evitar puxar e rasgar.

**IT** Se la copertura ha una cerniera, aprila prima di procedere con l'installazione esterna per evitare strappi e lacerazioni.

**RO** Dacă husa are un fermoar, vă rugăm să-l deschideți înainte de a începe instalarea externă, pentru a evita smulgerea sau ruperea materialului.

**PL** Jeśli na pokrowcu znajduje się zamek błyskawiczny, przed przystąpieniem do montażu zewnętrznego należy go rozpiąć, aby uniknąć szarpania i rozdarcia.

If you have any questions, please contact our customer care center, Our contact details are below:

**US**

 001-877-644-9366

 customerservice@aosom.com

Imported by Aosom LLC  
7777 Center Ave. Suite 430  
Huntington Beach, CA 92647-9998 USA  
MADE IN CHINA

If you have any questions, please contact our customer care center, Our contact details are below:

**UK**

 0044-800-240-4004

 enquiries@mhstar.co.uk

IMPORTER ADDRESS:  
MH STAR UK Ltd  
1 Northampton Cross Logistics Park  
Northampton Cross Road  
Northampton  
NN4 9FH  
MADE IN CHINA

If you have any questions, please contact our customer care center, Our contact details are below:

**CA**

 416-792-6088

 customerservice@aosom.ca

Imported by Aosom Canada Inc.  
7270 Woodbine Avenue, Unit 307, Markham,  
Ontario Canada L3R 4B9  
MADE IN CHINA

Si vous avez la moindre question, veuillez contacter notre centre d'assistance à la clientèle, Nos coordonnées sont les suivantes:

 416-792-6088

 customerservice@aosom.ca

Importé par Aosom Canada Inc.  
7270 Woodbine Avenue, unité 307,  
Markham, Ontario Canada L3R 4B9  
FABRIQUÉ EN CHINE

Wenn Sie Fragen haben, wenden Sie sich bitte an unser Kundendienstzentrum, Unsere Kontaktdaten stehen unten:

**DE**

 0049-0(40)-87408465

 service@aosom.de

ADRESSE DES IMPORTEUR/Hersteller/REP:  
MH Handel GmbH  
Wendenstraße 309  
D-20537 Hamburg  
Germany  
IN CHINA HERGESTELLT

In caso di dubbio, si prega di contattare il nostro centro assistenza clienti, I nostri dettagli di contatto sono di seguito:

**IT**

 0039-0249471447

 clienti@aosom.it

IMPORTATO DA/Produttore/REP:  
AOSOM Italy srl  
Centro Direzionale Milanofiori  
Strada 1 Palazzo F1  
20057 Assago (MI)  
P.I.: 08567220960  
FATTO IN CINA

Si tiene alguna pregunta, comuníquese con nuestro Centro de Atención al Cliente, Nuestros datos de contacto son los siguientes:

**ES**

 0034-931294512

 atencioncliente@aosom.es

IMPORTADOR/Fabricante/REP:  
SPANISH AOSOM, S.L.  
C/ROC GROS, Nº15.08550, ELS HOSTALET DE  
BALENYÀ, SPAIN.  
B66295775  
HECHO EN CHINA

Se tiver alguma dúvida, por favor contacte o nosso Centro de Atendimento ao Cliente, Os nossos dados de contacto são os seguintes:

 0034-931294512

 info@aosom.pt.

Dacă aveți întrebări, vă rugăm să contactați serviciul nostru clienți. Datele de contact sunt mai jos.

**RO**

 +40 312294730

 Clienti@aosom.ro

Importator/Producător/REP:  
Aosom Romania SRL  
Str. Barbu Mumuleanu, nr. 30-32  
Bucuresti, Sector 2  
FABRICAT IN CHINA

Si vous avez la moindre question, veuillez contacter notre centre d'assistance à la clientèle, Nos coordonnées sont les suivantes:

**FR**

 0033-1-84166106

 aosom@mhfrance.fr

Importé par/Fabricant/REP:  
MH FRANCE  
2 Rue Maurice Hartmann  
92130 Issy Les Moulineaux  
France  
FABRIQUÉ EN CHINE



FR

**DONNEZ  
OU  
RECYCLEZ**



ASSOCIATION

OU



LIVRAISON

OU



DÉCHÈTERIE

Adresses sur [quefairedemesdechets.fr](http://quefairedemesdechets.fr)