

Vinsetto

IN241000201V02_GL

838-428V00

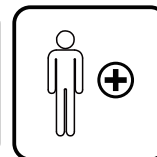
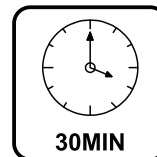
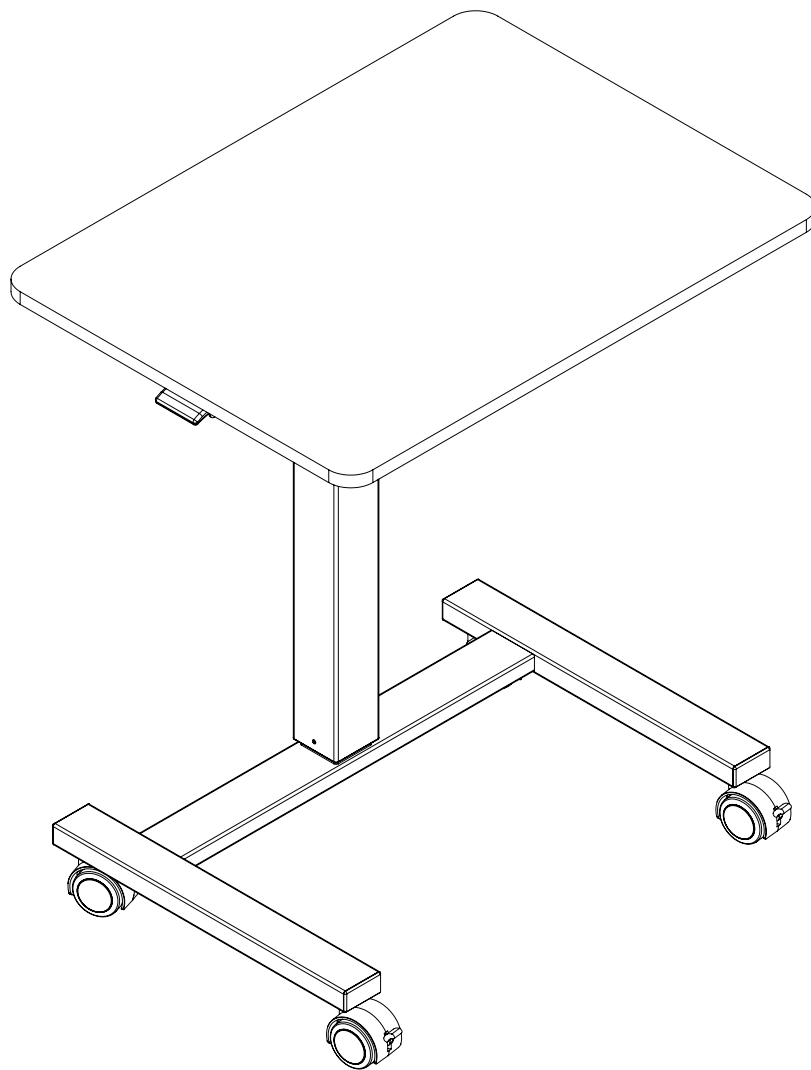

EN_IMPORTANT, RETAIN FOR FUTURE REFERENCE: READ CAREFULLY.

FR_IMPORTANT: A LIRE ATTENTIVEMENT ET A CONSERVER POUR VOUS Y REFRERER ULTERIEUREMENT

ES_IMPORTANTE, LEA DETENIDAMENTE Y GUARDE PARA FUTURAS REFERENCIAS.

PT_IMPORTANTE, GARDE PARA FUTURA REFERÊNCIA, LEIA ATENTAMENTE.

DE_WICHTIG! SORFGFÄLTIG LESEN UND FÜR SPÄTERES NACHSCHLAGEN AUFBEWAHREN.

IT_IMPORTANTE, LEGGERE E CONSERVARE QUESTO MANUALE D'ISTRUZIONE PER UN USO FUTURO.

RO_IMPORTANT, DE PĂSTRAT PENTRU REFERINȚE VIITOARE: CITIȚI CU ATENȚIE.



Read the entire instruction manual before you start installation and assembly. If you have any questions regarding any of the instructions or warnings, please contact the purchasing merchant for assistance.



CAUTION: Use with products heavier than the rated weights indicated may result in instability causing possible injury.

- Mounts must be attached as specified in assembly instructions. Improper installation may result in damage or serious personal injury.
- Safety gear and proper tools must be used. This product should only be installed by professionals.
- Use the mounting screws provided and **DO NOT OVER TIGHTEN** mounting screws.
- This product contains small items that could be a choking hazard if swallowed. Keep these items away from children.
- This product is intended for indoor use only. Using this product outdoors could lead to product failure and personal injury.

IMPORTANT: Ensure that you have received all parts according to the component checklist prior to installation. If any parts are missing or faulty, please contact the purchasing merchant for a replacement.

MAINTENANCE: Check that the bracket is secure and safe to use at regular intervals (at least every three months).



Lisez intégralement le manuel d'instructions avant de commencer l'installation et l'assemblage.

Si vous avez des questions concernant les instructions ou les avertissements, veuillez contacter le marchand auprès duquel vous avez effectué l'achat pour obtenir de l'aide.



ATTENTION : L'utilisation avec des produits plus lourds que les poids indiqués peut entraîner une instabilité pouvant causer des blessures.

- Les supports doivent être fixés selon les instructions d'assemblage. Une installation incorrecte peut entraîner des dommages ou des blessures graves.
- Des équipements de sécurité et des outils appropriés doivent être utilisés. Ce produit ne doit être installé que par des professionnels.
- Utilisez les vis de montage fournies et **NE SERREZ PAS EXCESSIVEMENT** les vis de montage.
- Ce produit contient de petits éléments qui pourraient présenter un risque d'étouffement s'ils sont avalés. Gardez ces éléments hors de portée des enfants.
- Ce produit est destiné à un usage intérieur uniquement. L'utilisation en extérieur pourrait entraîner une défaillance du produit et des blessures.

IMPORTANT : Assurez-vous d'avoir reçu toutes les pièces selon la liste de contrôle des composants avant l'installation. Si des pièces manquent ou sont défectueuses, veuillez contacter le marchand auprès duquel vous avez effectué l'achat pour un remplacement.

ENTRETIEN : Vérifiez régulièrement (au moins tous les trois mois) que le support est sécurisé et sûr à utiliser.



Lesen Sie das gesamte Handbuch sorgfältig durch, bevor Sie mit der Installation und Montage beginnen.



Falls Sie Fragen zu den Anweisungen oder Warnhinweisen haben, wenden Sie sich bitte an den Händler, bei dem Sie den Kauf getätigt haben, um Unterstützung zu erhalten.

VORSICHT: Die Verwendung mit Produkten, die schwerer sind als die angegebenen maximalen Gewichte, kann zu Instabilität führen, die zu möglichen Verletzungen führen kann.

- Die Halterungen müssen gemäß den Montageanweisungen angebracht werden. Eine unsachgemäße Installation kann zu Schäden oder schweren Personenschäden führen.
- Schutzausrüstung und geeignete Werkzeuge müssen verwendet werden. Dieses Produkt darf nur von Fachpersonal installiert werden.
- Verwenden Sie die bereitgestellten Montageschrauben und **ÜBERDREHEN SIE DIE MONTAGESCHRAUBEN NICHT.**
- Dieses Produkt enthält kleine Teile, die ein Erstickungsrisiko darstellen können, wenn sie verschluckt werden. Halten Sie diese Teile von Kindern fern.
- Dieses Produkt ist ausschließlich für den Innenbereich gedacht. Die Verwendung im Freien kann zu Produktionsfehlern und Personenschäden führen.

WICHTIG: Stellen Sie sicher, dass Sie vor der Installation alle Teile gemäß der Komponenten-Checkliste erhalten haben. Wenn Teile fehlen oder defekt sind, wenden Sie sich bitte an den Händler, bei dem Sie den Kauf getätigt haben, um einen Ersatz zu erhalten.

WARTUNG: Überprüfen Sie regelmäßig (mindestens alle drei Monate), ob der Halter sicher und funktionsfähig ist.



Lea todo el manual de instrucciones antes de comenzar la instalación y el ensamblaje.



Si tiene alguna duda sobre las instrucciones o advertencias, por favor contacte al comerciante donde realizó la compra para obtener asistencia.

PRECAUCIÓN: El uso con productos más pesados que los pesos indicados puede provocar inestabilidad y posibles lesiones.

- Los soportes deben instalarse según las instrucciones de ensamblaje. Una instalación incorrecta puede causar daños o lesiones graves.
- Deben usarse equipos de seguridad y herramientas adecuadas. Este producto solo debe ser instalado por profesionales.
- Use los tornillos de montaje proporcionados y **NO APRETARLOS EN EXCESO.**
- Este producto contiene piezas pequeñas que podrían representar un riesgo de asfixia si se tragan. Mantenga estas piezas fuera del alcance de los niños.
- Este producto está destinado únicamente para uso en interiores. Usarlo al aire libre puede provocar fallos del producto y lesiones personales.

IMPORTANTE: Asegúrese de haber recibido todas las piezas según la lista de componentes antes de la instalación. Si faltan piezas o están defectuosas, por favor contacte al comerciante donde realizó la compra para un reemplazo.

MANTENIMIENTO: Verifique que el soporte esté seguro y apto para su uso a intervalos regulares (al menos cada tres meses).



Leia todo o manual de instruções antes de iniciar a instalação e a montagem. Se tiver alguma dúvida sobre as instruções ou avisos, por favor, entre em contato com o comerciante onde realizou a compra para assistência.



CUIDADO: O uso com produtos mais pesados que os pesos indicados pode resultar em instabilidade e possíveis lesões.

- Os suportes devem ser fixados conforme as instruções de montagem. Uma instalação inadequada pode causar danos ou lesões graves.
- Devem ser usados equipamentos de segurança e ferramentas adequadas. Este produto deve ser instalado apenas por profissionais.
- Use os parafusos de montagem fornecidos e **NÃO APERTE EXCESSIVAMENTE** os parafusos de montagem.
- Este produto contém itens pequenos que podem representar risco de engasgo se engolidos. Mantenha esses itens fora do alcance de crianças.
- Este produto é destinado apenas para uso interno. Usá-lo ao ar livre pode levar a falhas do produto e lesões pessoais.

IMPORTANTE: Certifique-se de que recebeu todas as peças de acordo com a lista de componentes antes da instalação. Se alguma peça estiver faltando ou com defeito, por favor, entre em contato com o comerciante onde realizou a compra para uma substituição.

MANUTENÇÃO: Verifique regularmente se o suporte está seguro e apto para uso (pelo menos a cada três meses).



Leggi interamente il manuale di istruzioni prima di iniziare l'installazione e l'assemblaggio.

Se hai domande su istruzioni o avvertenze, contatta il rivenditore presso cui hai effettuato l'acquisto per assistenza.



ATTENZIONE: L'uso con prodotti più pesanti dei pesi indicati può causare instabilità e possibili lesioni.

- I supporti devono essere fissati come specificato nelle istruzioni di assemblaggio. Un'installazione impropria può provocare danni o lesioni gravi.
- Devono essere utilizzati dispositivi di sicurezza e strumenti adeguati. Questo prodotto deve essere installato solo da professionisti.
- Usa le viti di montaggio fornite e **NON STRINGERE ECCESSIVAMENTE** le viti di montaggio.
- Questo prodotto contiene piccoli oggetti che possono rappresentare un rischio di soffocamento se ingeriti. Tieni questi oggetti lontano dai bambini.
- Questo prodotto è destinato solo all'uso interno. L'uso all'esterno può portare a guasti del prodotto e lesioni personali.

IMPORTANTE: Assicurati di aver ricevuto tutte le parti secondo l'elenco dei componenti prima dell'installazione. Se mancano parti o sono difettose, contatta il rivenditore presso cui hai effettuato l'acquisto per una sostituzione.

MANUTENZIONE: Controlla regolarmente che il supporto sia sicuro e utilizzabile a intervalli regolari (almeno ogni tre mesi).



Citiți întregul manual de instrucțiuni înainte de a începe instalarea și asamblarea. Dacă aveți întrebări privind oricare dintre instrucțiuni sau avertismente, vă rugăm să contactați comerciantul de la care ați făcut achiziția pentru asistență.



PRECAUȚIE: Utilizarea cu produse mai grele decât greutatea nominale indicate poate duce la instabilitate, cauzând posibile vătămări.

- Suporturile trebuie fixate conform specificațiilor din instrucțiunile de asamblare. Instalarea necorespunzătoare poate duce la deteriorări sau vătămări corporale grave.
- Trebuie utilizate echipamente de protecție și unelte corespunzătoare. Acest produs ar trebui instalat doar de către profesioniști.
- Utilizați șuruburile de montare furnizate și **NU STRÂNGEȚI EXCESIV** șuruburile de montare.
- Acest produs conține piese mici care ar putea reprezenta un pericol de sufocare dacă sunt înghițite. Țineți aceste piese departe de copii.
- Acest produs este destinat exclusiv utilizării în interior. Utilizarea acestui produs în exterior poate duce la defectarea produsului și la vătămări corporale.

IMPORTANT: Asigurați-vă că ați primit toate piesele conform listei de componente înainte de instalare. Dacă lipsesc piese sau sunt defecte, vă rugăm să contactați comerciantul de la care ați făcut achiziția pentru o înlocuire.

ÎNTREȚINERE: Verificați dacă suportul este fixat corect și sigur pentru utilizare la intervale regulate (cel puțin o dată la trei luni).

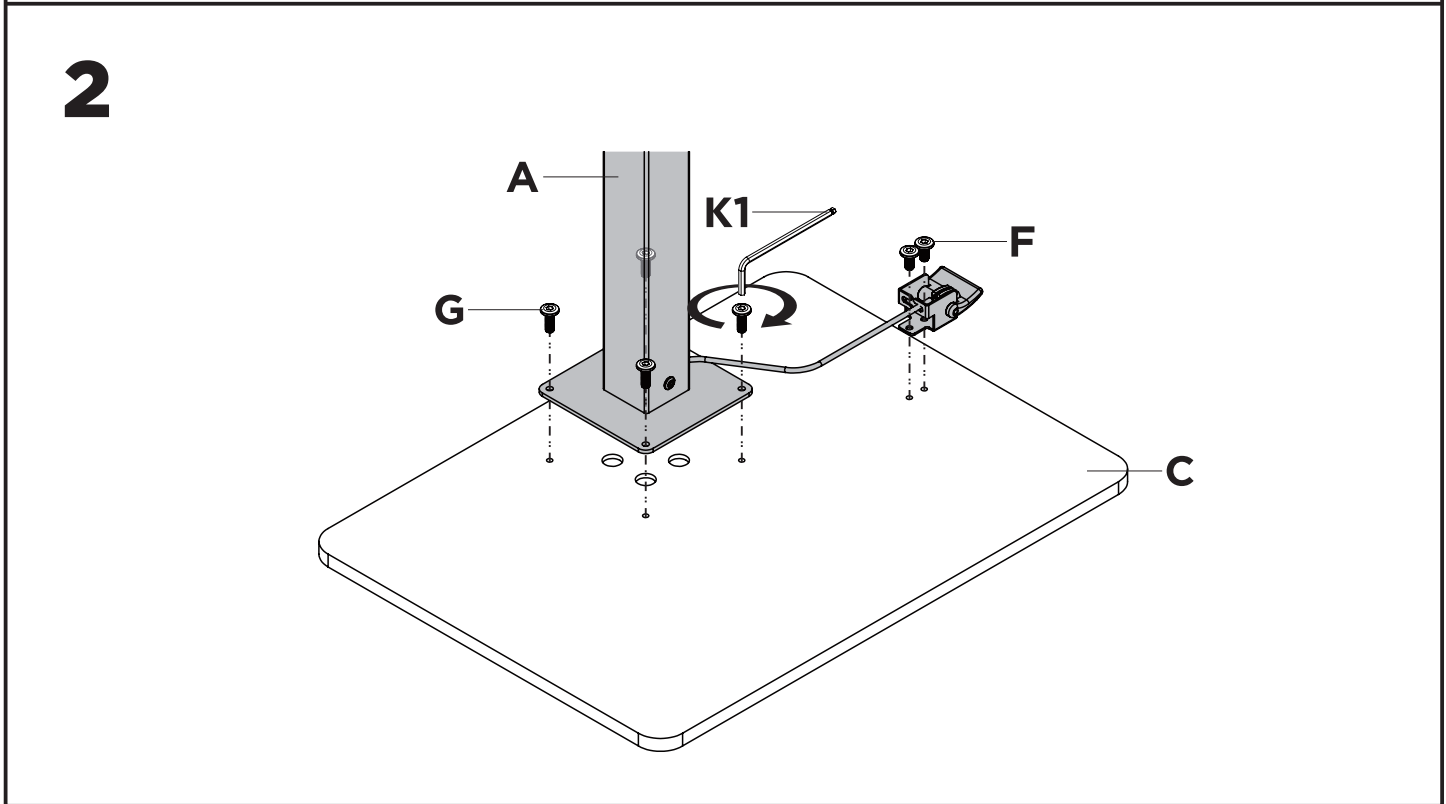
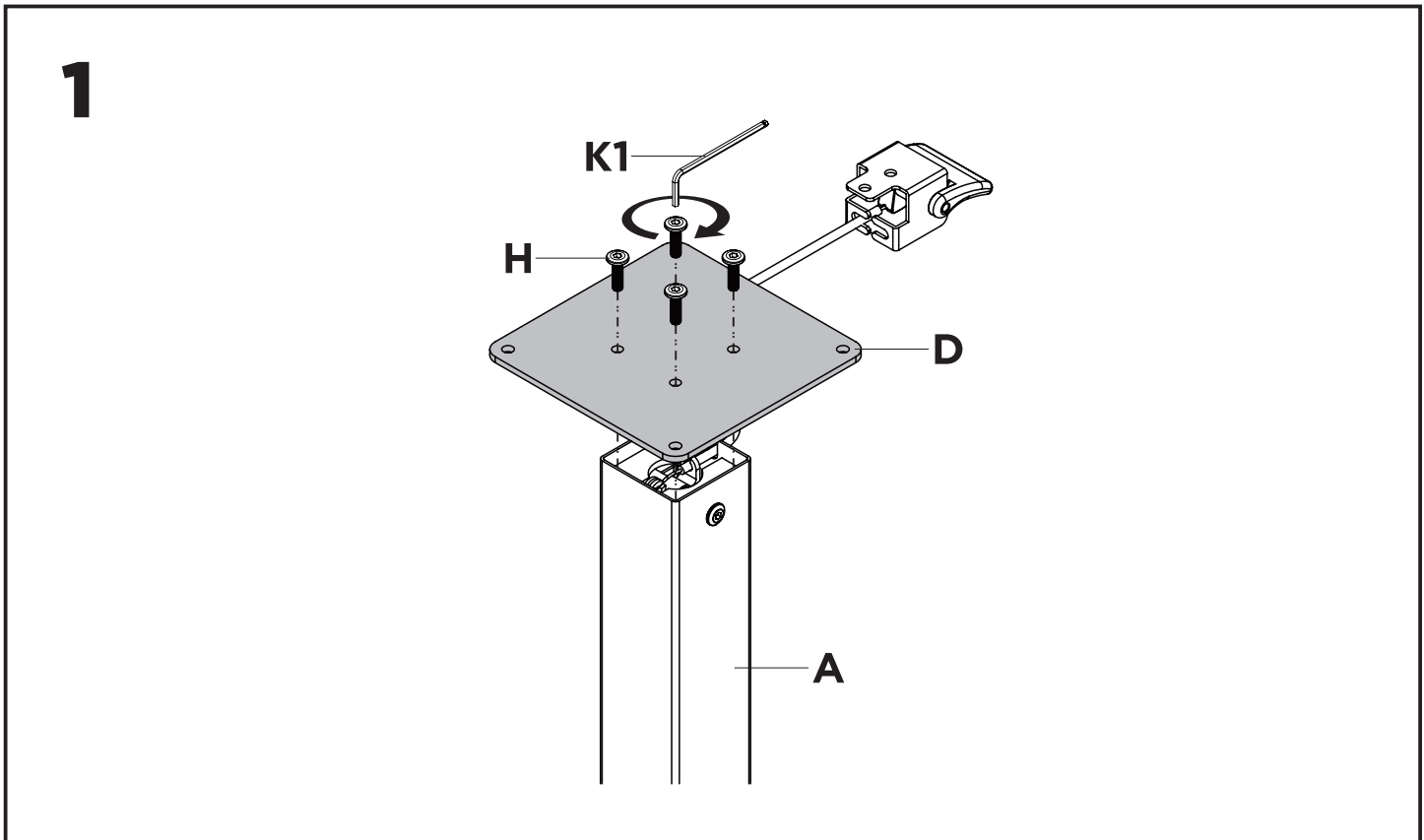
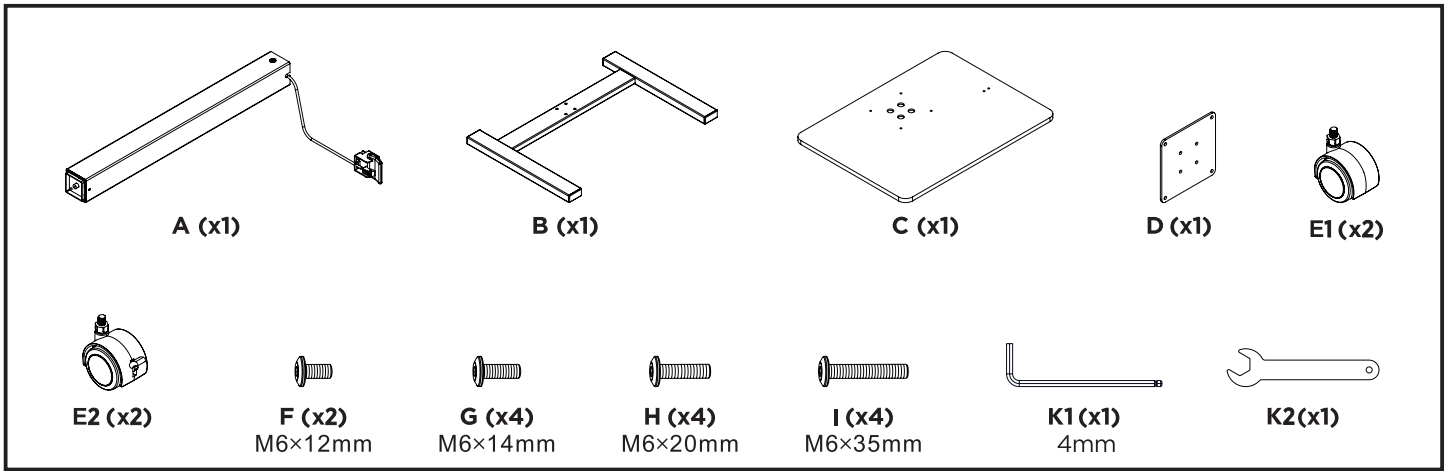

3

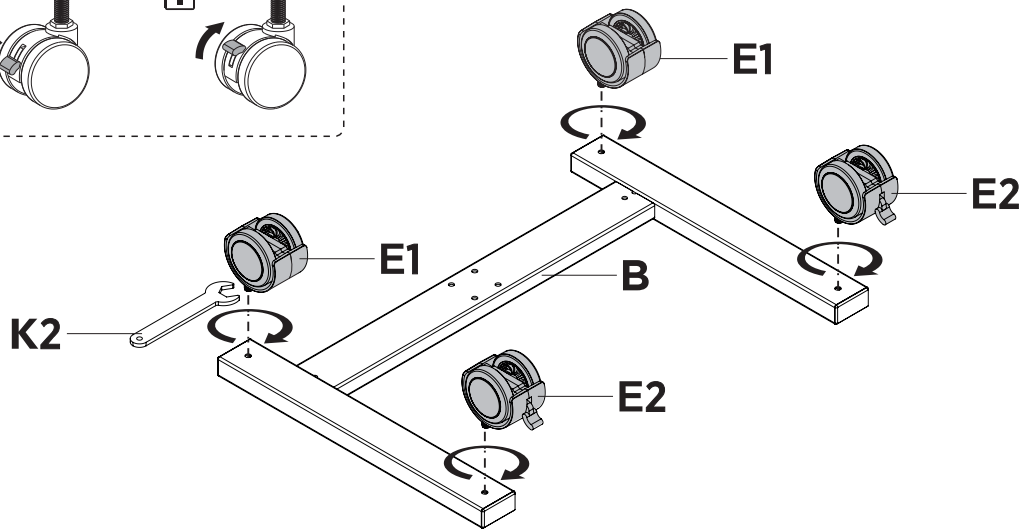
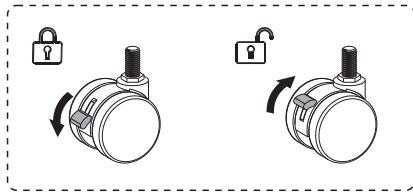

4

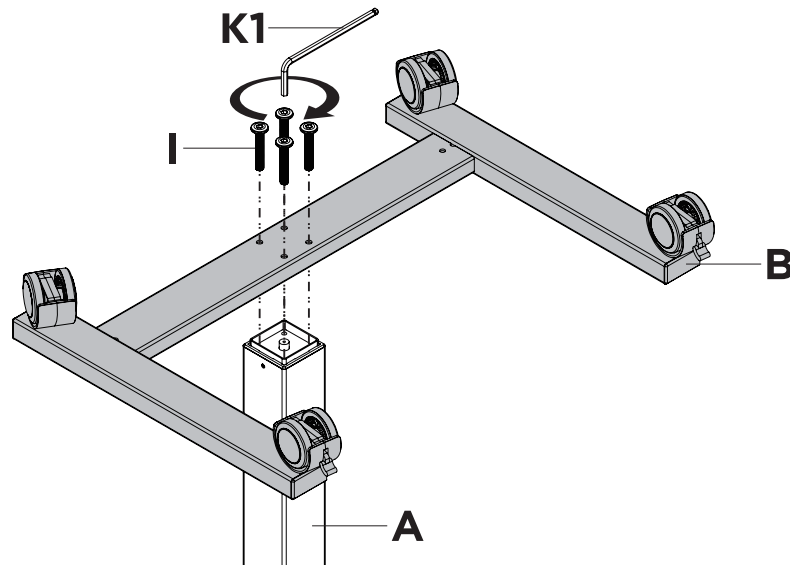

5



EN: WARNING: Pay attention to accidental injury caused by sudden rise of the table.

FR: AVERTISSEMENT : Faites attention aux blessures accidentelles causées par la montée soudaine de la table.

ES: ADVERTENCIA: Preste atención a las lesiones accidentales causadas por el levantamiento repentino de la mesa.

PT: AVISO: Atenção para lesões acidentais causadas pela subida repentina da mesa.

DE: WARNUNG: Achten Sie auf versehentliche Verletzungen durch plötzliches Anheben des Tisches.

IT: AVVERTENZA: Prestare attenzione a lesioni accidentali causate dall'improvviso sollevamento del tavolo.

RO: AVERTISMENT: Acordați atenție vătămarilor accidentale cauzate de ridicarea bruscă a mesei.

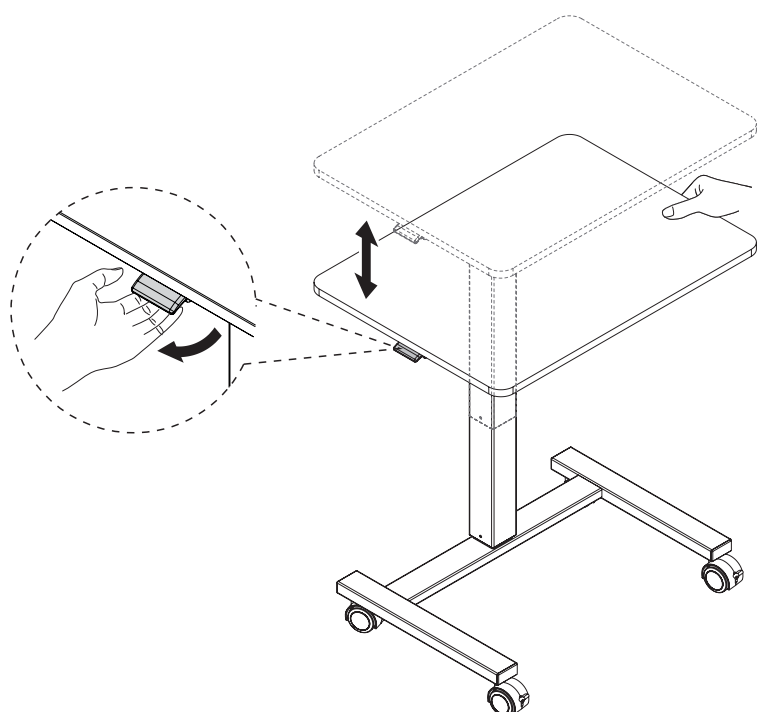

If you have any questions, please contact our customer care center, Our contact details are below:

US

 001-877-644-9366

 customerservice@aosom.com

Imported by Aosom LLC
7777 Center Ave. Suite 430
Huntington Beach, CA 92647-9998 USA
MADE IN CHINA

Wenn Sie Fragen haben, wenden Sie sich bitte an unser Kundendienstzentrum, Unsere Kontaktdaten stehen unten:

DE

 +49 40 87408465

 service@aosom.de

ADRESSE DES IMPORTEURE/Hersteller/REP:
MH Handel GmbH
Wendenstraße 309
D-20537 Hamburg
Germany
IN CHINA HERGESTELLT

If you have any questions, please contact our customer care center, Our contact details are below:

CA

 416-792-6088

 customerservice@aosom.ca

Imported by Aosom Canada Inc.
7270 Woodbine Avenue, Unit 307, Markham,
Ontario Canada L3R 4B9
MADE IN CHINA

Si vous avez la moindre question, veuillez contacter notre centre d'assistance à la clientèle, Nos coordonnées sont les suivantes:

 416-792-6088

 customerservice@aosom.ca

Importé par Aosom Canada Inc.
7270 Woodbine Avenue, unité 307,
Markham, Ontario Canada L3R 4B9
FABRIQUÉ EN CHINE

In caso di dubbio, si prega di contattare il nostro centro assistenza clienti, I nostri dettagli di contatto sono di seguito:

IT

 0039-0249471447

 clienti@aosom.it

IMPORTATO DA/Produttore/REP:
AOSOM Italy srl
Centro Direzionale Milanofiori
Strada 1 Palazzo F1
20057 Assago (MI)
P.I.: 08567220960
FATTO IN CINA

Si tiene alguna pregunta, comuníquese con nuestro Centro de Atención al Cliente, Nuestros datos de contacto son los siguientes:

ES

 0034-931294512

 atencioncliente@aosom.es

IMPORTADOR/Fabricante/REP:
SPANISH AOSOM, S.L.
C/ROC GROS, N°15.08550, ELS HOSTALETES DE
BALENYÀ, SPAIN.
B66295775
HECHO EN CHINA

Se tiver alguma dúvida, por favor contacte o nosso Centro de Atendimento ao Cliente, Os nossos dados de contacto são os seguintes:

 0034-931294512

 info@aosom.pt.

IMPORTADOR/Fabricante/REP:
SPANISH AOSOM, S.L.
C.ROC GROS N.15, 08550. ELS HOSTALETES DE
BALENYÀ
FEITO NA CHINA

If you have any questions, please contact our customer care center, Our contact details are below:

UK

 0044-800-240-4004

 enquiries@mhstar.co.uk

IMPORTER ADDRESS:
MH STAR UK Ltd
1 Northampton Cross Logistics Park
Northampton Cross Road
Northampton
NN4 9FH
MADE IN CHINA

Si vous avez la moindre question, veuillez contacter notre centre d'assistance à la clientèle, Nos coordonnées sont les suivantes:

FR

 0033-1-84166106

 aosom@mhfrance.fr

Importé par/Fabricant/REP:
MH FRANCE
2 Rue Maurice Hartmann
92130 Issy Les Moulineaux
France
FABRIQUÉ EN CHINE



FR

**DONNEZ
OU
RECYCLEZ**



ASSOCIATION

OU



LIVRAISON

OU



DÉCHÈTERIE

Adresses sur quefairedemesdechets.fr