

UK

If you have any questions, please contact our customer care center.

Our contact details are below:



0044-800-240-4004



enquiries@mhstar.co.uk

IMPORTER ADDRESS:

MH STAR UK Ltd
1 Northampton Cross Logistics Park
Northampton Cross Road
Northampton
NN4 9FH
Made in china

IT

In caso di dubbio, si prega di contattare il nostro centro assistenza clienti. I nostri dettagli di contatto sono di seguito:



0039-0249471447



clienti@aosom.it

IMPORTATO DA/Produttore/REP:

AOSOM Italy srl
Centro Direzionale Milanofiori
Strada 1 Palazzo F1
20057 Assago (MI)
P.I.: 08567220960
FATTO IN CHINA

ES

Si tiene alguna pregunta, comuníquese con nuestro Centro de Atención al Cliente. Nuestros datos de contacto son los siguientes:



0034-931294512



atencioncliente@aosom.es

Importador/Fabricante/REP:

Spanish Aosom, S.L.
C/ Roc Gros, n° 15. 08550, Els Hostalets de Balenyà, Spain.
B66295775
www.aosom.es
atencioncliente@aosom.es
TEL: 931294512
HECHO EN CHINA

DE

Wenn Sie Fragen haben, wenden Sie sich bitte an unser Kundendienstzentrum. Unsere Kontaktdaten stehen unten:



0049-0(40)-87408465



service@aosom.de

Importeur/Hersteller/REP:

MH Handel GmbH
Wendenstraße 309
D-20537 Hamburg
Germany
IN CHINA HERGESTELLT

FR

Si vous avez la moindre question, veuillez contacter notre centre d'assistance à la clientèle.

Nos coordonnées sont les suivantes:



0033-1-84166106



aosom@mhfrance.fr

Importé par/Fabricant/REP:

MH France
2, rue Maurice Hartmann
92130 Issy-les-Moulineaux
France
Fabriqué en Chine

Se tiver alguma dúvida, por favor contacte o nosso Centro de Atendimento ao Cliente. Os nossos dados de contacto são os seguintes:



0034-931294512



info@aosom.pt.

IMPORTADOR:

SPANISH AOSOM, S.L
C.ROC GROS N.15, 08550. ELS HOSTALETES DE BALENYÀ
TEL: 931294512 (SEG-SEX DAS 7:30H ÀS 16:30H)
INFO@AOSOM.PT
WWW.AOSOM.PT

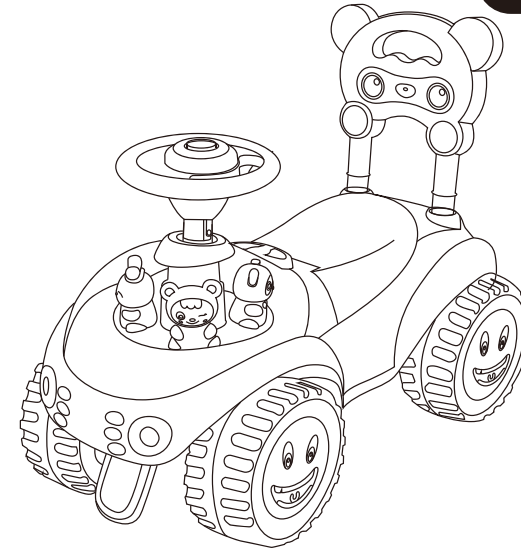

Foot to floor Vehicle
Fuß bis Boden Fahrzeug
Vehículo con el pedal a fondo
Véhicule à poser le pied au sol
Veicolo da piedi a terra



WARNING! Suitable for children of 18 months+; Max weight: 25 kg.

ATTENTION ! Convient aux enfants de 18 mois et plus ; poids maximum : 25 kg.

ATTENZIONE! Adatto a bambini di 18 mesi+; Peso massimo: 25 kg.

ACHTUNG! Geeignet für Kinder ab 18 Monaten; Maximalgewicht: 25 kg.

¡ADVERTENCIA! Apto para niños a partir de 18 meses; Peso máximo: 25 kg.

EN_IMPORTANT, RETAIN FOR FUTURE REFERENCE: READ CAREFULLY.

FR_IMPORTANT : A LIRE ATTENTIVEMEN ET A CONSERVER POUR VOUS Y REFERER ULTERIEUREMENT

ES_IMPORTANTE, LEA Y GUARDE PARA FUTURAS REFERENCIAS.

DE_WICHTIG! SORGFÄLTIG LESEN UND FÜR SPÄTER NACHSCHLAGEN AUFBEWAHREN.

IT_IMPORTANTE! CONSERVARE IL PRESENTE MANUALE PER FUTURO RIFERIMENTO E LEGGERLO ATTENTAMENTE.

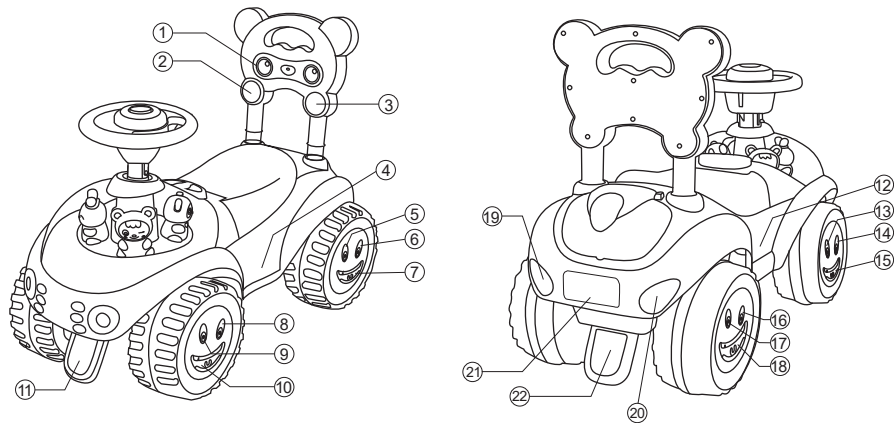

Part List

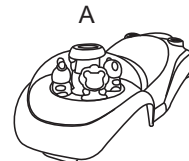

Car Body x1



Steering Wheel x1



Backrest x1



Steering Shaft x1



Wheel Trim Cover x4

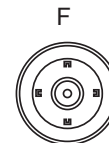

Wheels x4

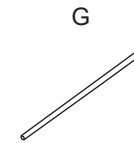

Iron Rods x2



Anti-Tip Brackets x2

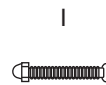

Screw Rod x1



Pins x2



Steel Wall Nails x4



Wheel Spacers x2



Screw Washers x4

Assembly Schematic

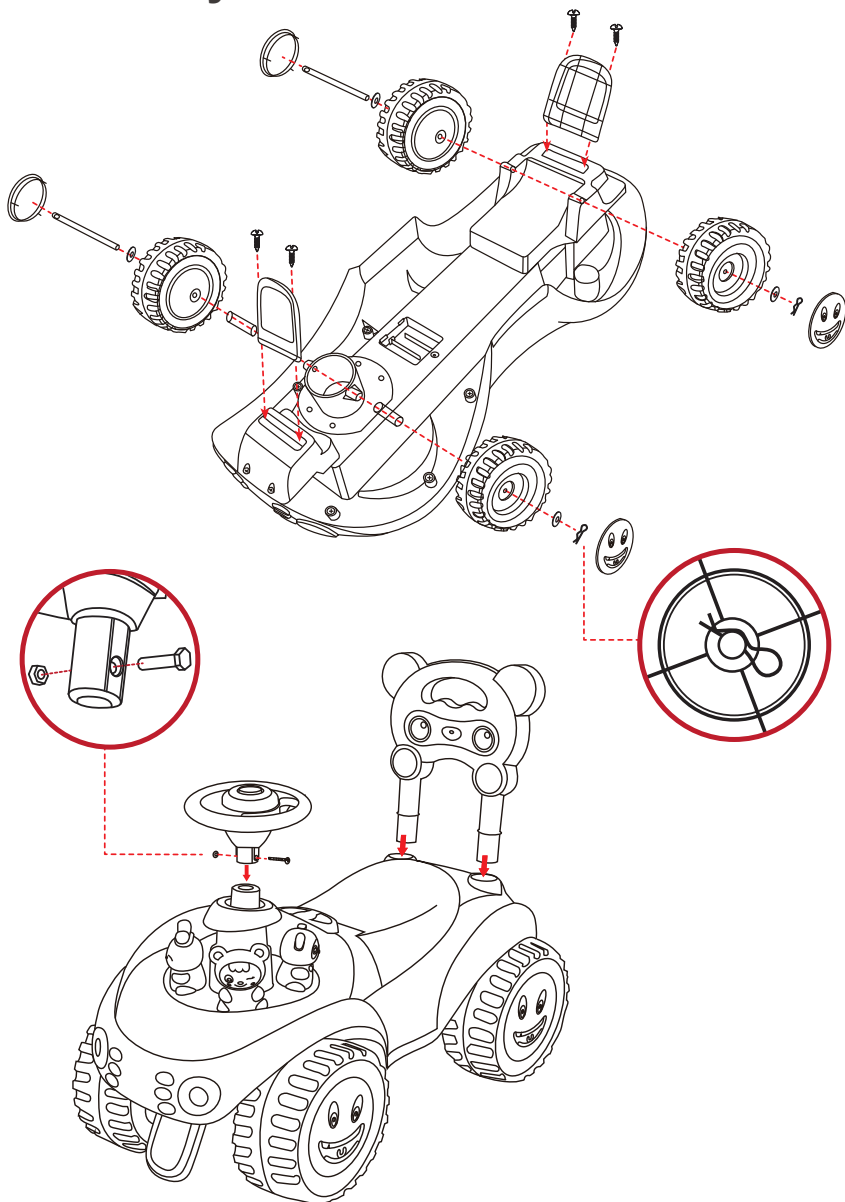

WARNING

1. This product is suitable for children for 18 months;
2. This product may have potential sharp edges, tips or small parts before assembly and must be assembled by adults;
3. Children should ride this on flat and smooth surface, and should keep away from traffic road; Strictly prohibited in nearby motor vehicles, streets, steps, slopes, hills, roads, alleys, swimming pools or other places with water;
4. Keep four wheels on the ground while playing, and do not play on a slope more than 10°.
5. This product shall be used under the custody of adults and shall wear shoes;
6. This product is only limited to one-person ride, with a maximum carrying capacity of 25 kg;
7. Adult assembly and installation of all parts are required.
8. Do not let Children playing alone with this product prevent from danger of Falling.
9. The toy should be used with caution since skill is required to avoid falls or collisions causing injury to the user or third parties.



WARNING

- Must be assembled by an adult, and that in their unassembled state contain potentially hazardous sharp edges or sharp points, or small parts.
- This toy produces flashes that may trigger epilepsy in sensitised individuals.

Assembly Instructions

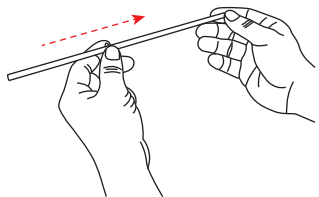

1. Insert a washer (M) onto the iron rod (G).

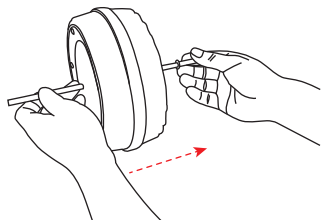

2. Next, slide a wheel (F) onto the same end of the iron rod (G).

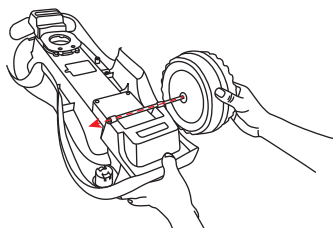

3. Insert the iron rod (G) through the corresponding hole and pass it through the rear base of the main body (A).

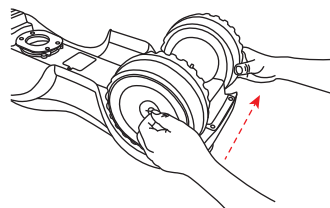

4. On the other end of the iron rod (G), sequentially slide on a wheel (F) and a washer (M), and then insert a pin (J) into the hole at the end of the iron rod.

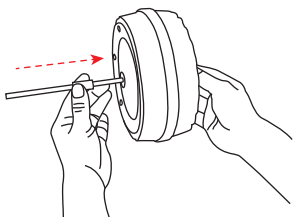

5. Sequentially slide a washer (M), a wheel (F), and a wheel spacer (L) onto the iron rod (G).

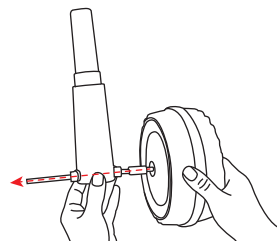

6. Insert the iron rod (G) through the corresponding hole and pass it through the steering shaft (D).

Precaution on installation of batteries

1. Children must under adult Supervision when install batteries.
2. Keep assembly tools out of sight and reach of children.
3. Leaking AA batteries are longer functional and have to throw to the disposable bins properly.
4. Do not mix different battery bands within the device, different types of batteries or new and used batteries are not to be mixed.
5. Requires 1.5V AA batteries. 1.5 V + \square \times 3
6. Non rechargeable batteries can not to be charged.
7. Rechargeable batteries are only to be charged under adult supervision.
8. Rechargeable batteries must be removed from the product before being charged.
9. Install batteries with polarity are shown inside the battery compartment. Batteries are to be inserted with the correct polarity (+ and -).
10. Remove batteries in charger if necessary.
11. Power supply should remain loading to the battery compartment.
12. Do not mix old and new batteries.
13. Do not mix alkaline, standard (carbon-zinc), or rechargeable (nickel-cadmium) batteries.
14. The supply terminals are not to be short-circuited.
15. Exhausted batteries are to be removed from the toy.

Maintenance & Care

1. Clean the surface frequently using soft cloth .
2. Avoid direct sun exposure.
3. Periodic inspection and maintenance are required on all fasteners.
4. Check Battery status frequently. Store the battery properly for future use.
5. Handle with Caution .

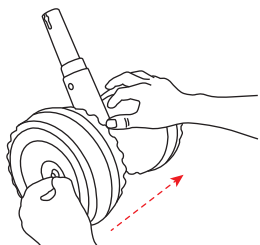

7. On the other end of the iron rod (G), sequentially slide on a wheel (F) and a washer (M), and then insert a pin (J) into the hole at the end of the iron rod.

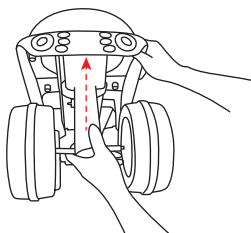

8. Insert the upper end of the steering shaft (D) through the front bottom of the main body (A) and pass it through the main body.

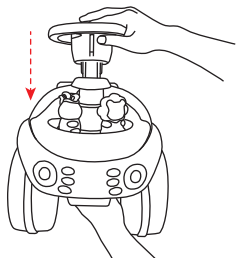

9. Slide the steering wheel (B) onto the upper end of the steering shaft, aligning the holes on both sides.

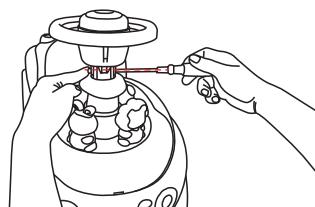

10. Insert the screw rod (I) into the side hole of the steering wheel (B), pass it through the holes of the steering wheel and the steering shaft, then secure it with a nut.

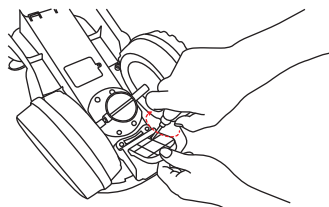

11. Lace the anti-tip brackets (H) in the positions shown in the diagram, and secure each with two steel wall nails (K).

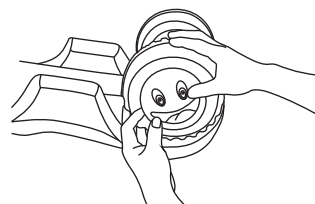

12. Align the clips of the wheel trim cover (E) with the slots on the outer side of the wheels, and press them firmly into place. Repeat for all four wheel trim covers.

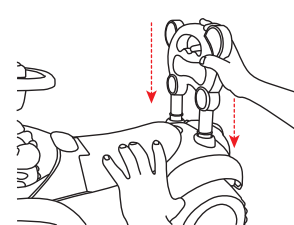

13. Insert the backrest (C) into the round hole at the rear of the main body until it clicks securely into place.

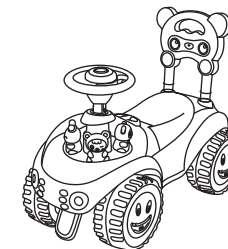

14. The assembly is now complete.

STEERING WHEEL BATTERY INSTALLATION AND REPLACEMENT DIAGRAM

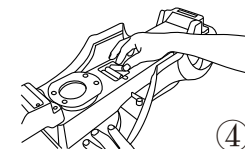
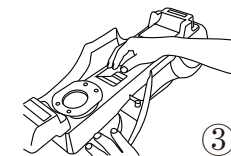
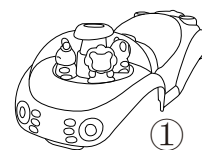

1. The battery box is located on the underside of the body.
2. Use a screwdriver to loosen the screws and remove the battery compartment cover.
3. Remove the battery cover.
4. Install 3 pieces of size 5 AA batteries (1.5V), and place them according to the symbols displayed (+,-).
5. Close the cover and tighten the screws.
6. To remove the batteries, reverse steps 2 and 3.

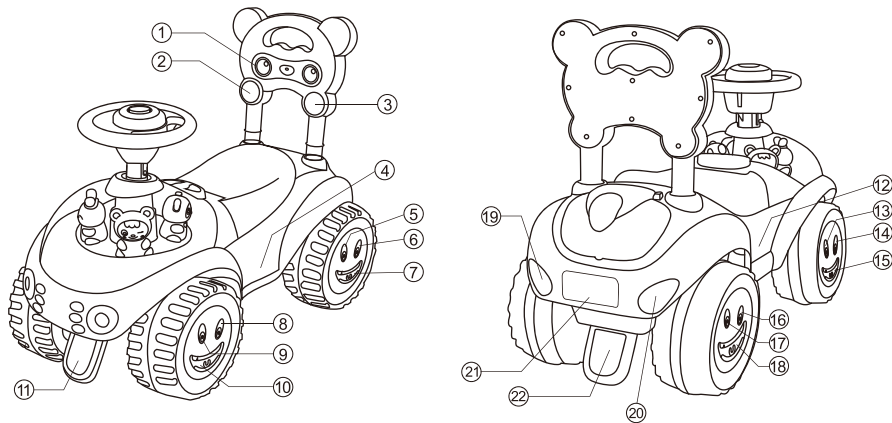

Liste des pièces

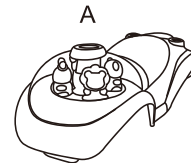

A Carrosserie x1



B Volant x1



C Dossier x1



D Arbre de direction x1



E Couvre-jantes x4

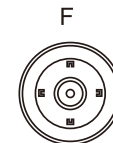

F Roues x4

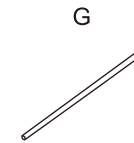

G Barres de fer x2



H Supports anti-basculement x2

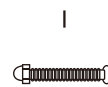

I Tige filetée x1



J Clous x2



K Clous pour mur en acier x4



L Entretoises de roue x2



M Rondelles de vis x4

Schéma d'assemblage

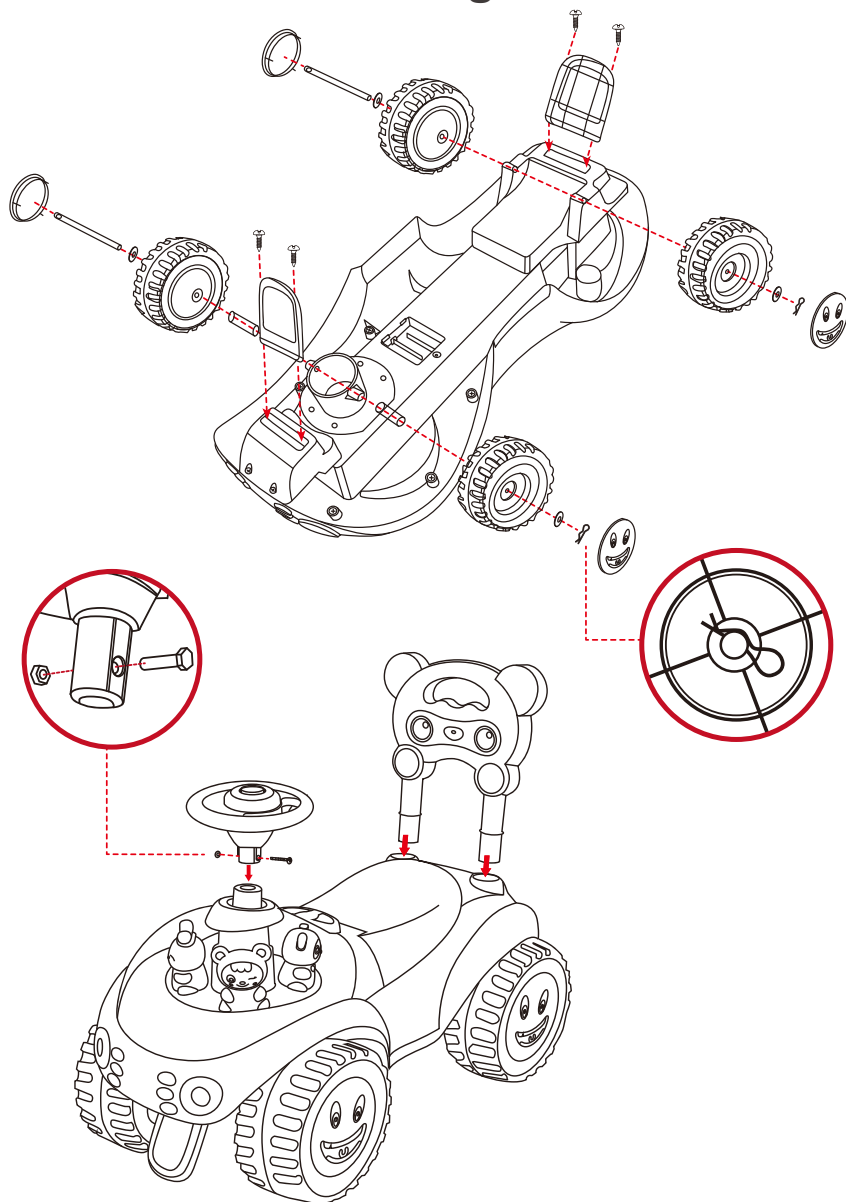

ATTENTION

1. Ce produit convient aux enfants pendant 18 mois;
2. Ce produit peut avoir des arêtes vives, des pointes ou de petites pièces potentielles avant l'assemblage et doit être assemblé par des adultes ;
3. Les enfants devraient monter cela sur une surface plane et lisse, et devraient se tenir à l'écart de la route de circulation ; Strictement interdit dans les véhicules à moteur à proximité, les rues, les marches, les pentes, les collines, les routes, les ruelles, les piscines ou d'autres endroits avec de l'eau ;
4. Gardez quatre roues au sol pendant que vous jouez, et ne jouez pas sur une pente de plus de 10°.
5. Ce produit doit être utilisé sous la garde d'adultes et doit porter des chaussures ;
6. Ce produit est limité à une seule personne, avec une capacité de charge maximale de 25 kg ;
7. L'assemblage et l'installation adultes de toutes les pièces sont nécessaires.
8. Ne laissez pas les enfants jouer seuls avec ce produit empêcher le danger de tomber.
9. Le jouet doit être utilisé avec prudence car la compétence est nécessaire pour éviter les chutes ou les collisions causant des blessures à l'utilisateur ou à des tiers.



ATTENTION

- Doit être assemblé par un adulte, et que dans leur état non assemblé contenir des arêtes vives potentiellement dangereuses ou des points tranchants, ou de petites pièces.
- Ce jouet produit des flashes qui peuvent déclencher l'épilepsie chez les personnes sensibles.



FR

Cet appareil,
ses accessoires,
cordons et batteries
se recyclent

REPRISE
À LA LIVRAISON



À DÉPOSER
EN MAGASIN



À DÉPOSER
EN DÉCHÈTERIE



Points de collecte sur www.quefairedemesdechets.fr
Privilégiez la réparation ou le don de votre appareil !

Instructions de montage

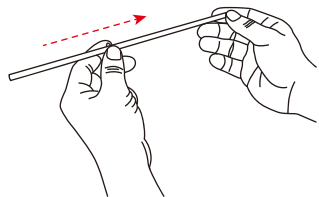

1. Insérez une rondelle (M) sur la tige en fer (G).

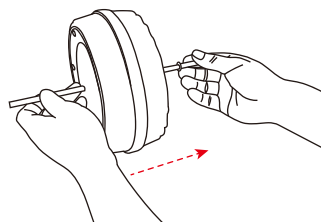

2. Ensuite, faites glisser une roue (F) sur la même extrémité de la tige en fer (G).

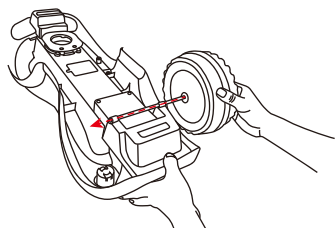

3. Insérez la tige en fer (G) à travers le trou correspondant et faites-la passer par la base arrière du corps principal (A).

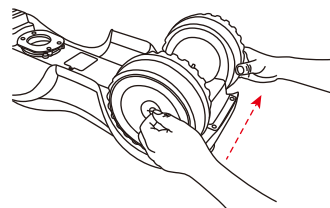

4. À l'autre extrémité de la tige en fer (G), faites glisser successivement une roue (F) et une rondelle (M), puis insérez une goupille (J) dans le trou à l'extrémité de la tige en fer.

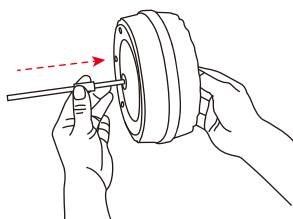

5. Faites glisser successivement une rondelle (M), une roue (F) et un entretoise de roue (L) sur la tige en fer (G).

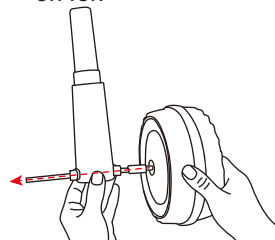

6. Insérez la tige en fer (G) dans le trou correspondant et faites-la passer à travers l'arbre de direction (D).

Précaution lors de l'installation des batteries

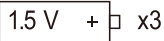
1. Les enfants doivent être sous la supervision d'un adulte lors de l'installation de batteries.
2. Gardez les outils d'assemblage hors de la vue et de la portée des enfants.
3. Les piles AA qui fuient sont plus fonctionnelles et doivent être jetées correctement dans les bacs jetables.
4. Ne mélangez pas différentes bandes de batterie dans l'appareil, différents types de batteries ou des batteries neuves et usagées ne doivent pas être mélangées.
5. Nécessite des batteries AA de 1,5 V. 
6. Les piles non rechargeables ne peuvent pas être chargées.
7. Les piles rechargeables ne doivent être chargées que sous la supervision d'un adulte.
8. Les piles rechargeables doivent être retirées du produit avant d'être chargées.
9. Installer des batteries avec polarité sont montrés à l'intérieur du compartiment de la batterie. Les batteries doivent être insérées avec la polarité correcte (+ et -).
10. Retirez les piles du chargeur si nécessaire.
11. L'alimentation électrique doit rester chargée dans le compartiment de la batterie.
12. Ne mélangez pas les anciennes et les nouvelles batteries.
13. Ne mélangez pas de piles alcalines, standard (carbone-zinc) ou rechargeables (nickel-cadmium).
14. Les terminaux d'approvisionnement ne doivent pas être court-circuités.
15. Les piles épuisées doivent être retirées du jouet.

Entretien et entretien

1. Nettoyez fréquemment la surface à l'aide d'un chiffon doux.
2. Évitez l'exposition directe au soleil.
3. Des inspections et un entretien périodiques sont requis sur toutes les fixations.
4. Vérifiez fréquemment l'état de la batterie. Rangez la batterie correctement pour une utilisation future.
5. Manipuler avec prudence.

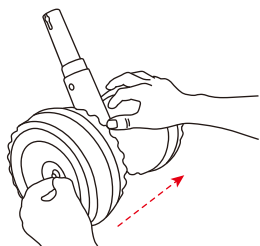

7. À l'autre extrémité de la tige en fer (G), faites glisser successivement une roue (F) et une rondelle (M), puis insérez une goupille (J) dans le trou à l'extrémité de la tige en fer.

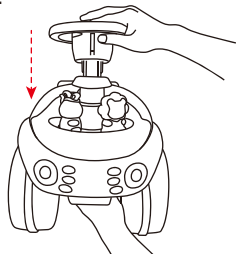

9. Faites glisser le volant (B) sur l'extrémité supérieure de l'arbre de direction, en alignant les trous des deux côtés.

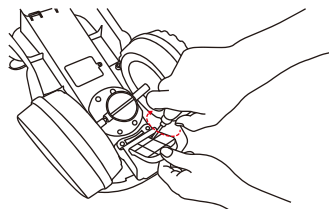

11. Placez les supports anti-basculement (H) aux emplacements indiqués sur le schéma, et fixez chacun avec deux clous en acier pour mur (K).

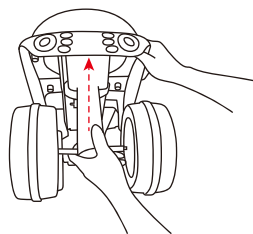

8. Insérez l'extrémité supérieure de l'arbre de direction (D) par le bas avant du corps principal (A) et faites-le passer à travers le corps principal.

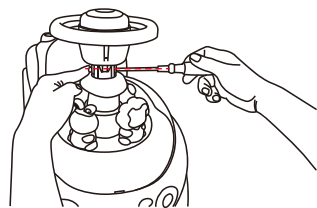

10. Insérez la tige filetée (I) dans le trou latéral du volant (B), faites-la passer à travers les trous du volant et de l'arbre de direction, puis fixez-la avec un écrou.

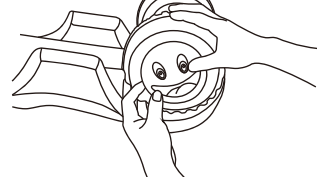

12. Alignez les clips du cache-roue (E) avec les fentes situées sur le côté extérieur des roues, puis appuyez fermement pour les fixer en place. Répétez l'opération pour les quatre caches-roues.

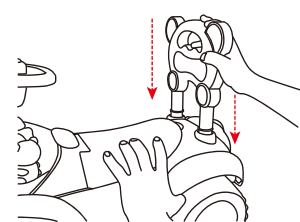

13. Insérez le dossier (C) dans le trou rond à l'arrière du corps principal jusqu'à ce qu'il s'enclenche solidement.

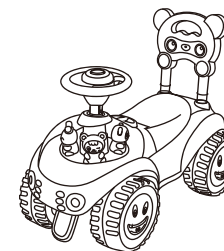

14. L'assemblage est maintenant terminé.

SCHÉMA D'INSTALLATION ET DE REMPLACEMENT DE LA BATTERIE DE VOLANT

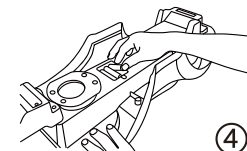
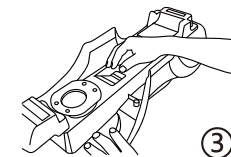
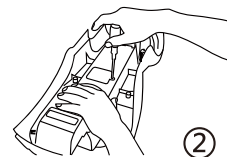
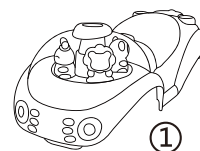

1. Le boîtier de la batterie est situé sur la face inférieure du corps.
2. Utilisez un tournevis pour desserrer les vis et retirer le couvercle du compartiment de la batterie.
3. Retirez le couvercle de la batterie.
4. Installez 3 pièces de piles AA de taille 5 (1,5 V) et placez-les selon les symboles affichés (+,-).
5. Fermez le couvercle et serrez les vis.
6. Pour retirer les piles, inversez les étapes 2 et 3.

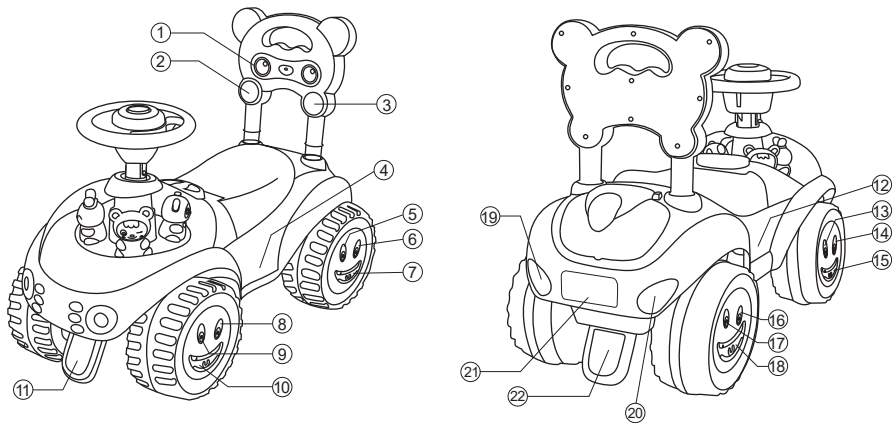

Teileliste

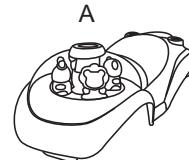

Fahrzeugkarosserie x1



Lenkrad x1



Rückenlehne x1

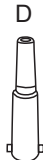

Lenkwelle x1



Radzierblende x4

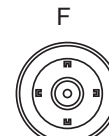

Räder x4

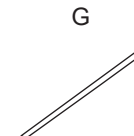

Eisenstangen x2



Zweifache Anti-Tipp-Klammern

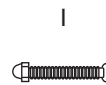

Gewindestange x1



Stifte x2



Stahlwandnägel x4



Radaufsteller x2



Schraubenscheiben x4

Montage-Schema

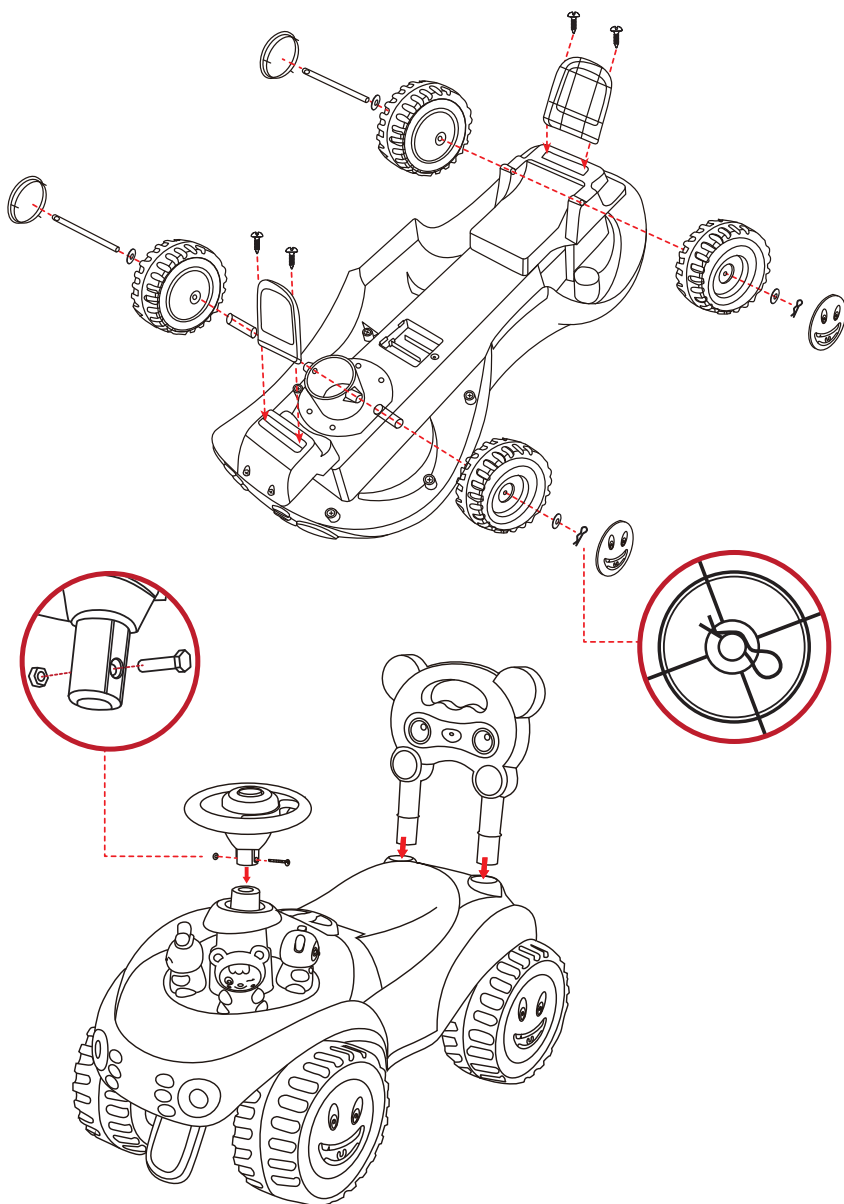

ACHTUNG

1. Dieses Produkt ist für Kinder ab 18 Monaten geeignet;
2. Dieses Produkt kann vor der Montage scharfe Kanten, Spitzen oder kleine Teile haben und muss von Erwachsenen zusammengebaut werden;
3. Kinder sollten dieses Produkt auf ebenen und glatten Flächen fahren und sich von Verkehrsstraßen fernhalten; Strengstens verboten in der Nähe von Kraftfahrzeugen, Straßen, Treppen, Steigungen, Hügeln, Wegen, Gassen, Schwimmbädern oder anderen Orten mit Wasser;
4. Halten Sie alle vier Räder während des Spielens auf dem Boden und spielen Sie nicht auf einer Neigung von mehr als 10°.
5. Dieses Produkt sollte unter Aufsicht von Erwachsenen verwendet werden und es sollten Schuhe getragen werden;
6. Dieses Produkt ist nur für eine Person geeignet und hat eine maximale Tragfähigkeit von 25 kg.
7. Die Montage und Installation aller Teile muss durch Erwachsene erfolgen.
8. Lassen Sie Kinder nicht unbeaufsichtigt mit diesem Produkt spielen, um Sturzgefahren zu vermeiden.
9. Das Spielzeug sollte mit Vorsicht verwendet werden, da Geschick erforderlich ist, um Stürze oder Kollisionen zu vermeiden, die zu Verletzungen des Benutzers oder Dritter führen könnten.



ACHTUNG

- Muss von einem Erwachsenen zusammengebaut werden und kann im unzusammengebauten Zustand potenziell gefährliche scharfe Kanten oder spitze Enden oder Kleinteile enthalten.
- Dieses Spielzeug erzeugt Lichtblitze, die bei empfindlichen Personen Epilepsie auslösen können.

Montageanleitung

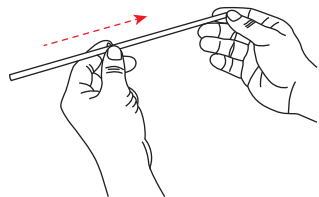

1. Setzen Sie eine Unterlegscheibe (M) auf den Eisenstab (G).

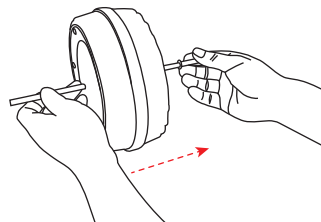

2. Als Nächstes schieben Sie ein Rad (F) auf dasselbe Ende der Eisenstange (G).

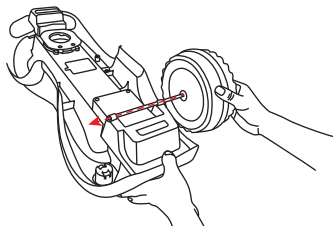

3. Führen Sie die Eisenstange (G) durch das entsprechende Loch und durch die hintere Basis des Hauptkörpers (A).

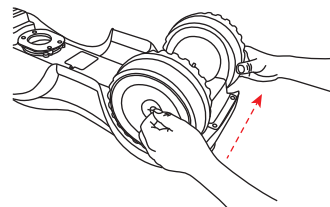

4. Am anderen Ende der Eisenstange (G) schieben Sie nacheinander ein Rad (F) und eine Unterlegscheibe (M) auf und stecken dann einen Stift (J) in das Loch am Ende der Eisenstange.

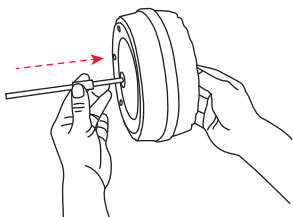

5. Schieben Sie nacheinander eine Unterlegscheibe (M), ein Rad (F) und einen Radabstandshalter (L) auf die Eisenstange (G).

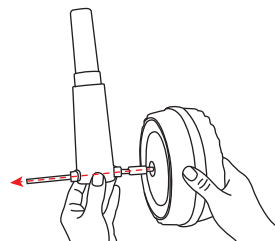

6. Stecken Sie die Eisenstange (G) durch das entsprechende Loch und führen Sie sie durch die Lenkwelle (D).

Vorsichtsmaßnahmen bei der Installation von Batterien

1. Kinder müssen unter Aufsicht von Erwachsenen stehen, wenn Batterien eingesetzt werden.
2. Halten Sie Montagewerkzeuge außer Sicht- und Reichweite von Kindern.
3. Auslaufende AA-Batterien sind nicht mehr funktionsfähig und müssen ordnungsgemäß in die Entsorgungsbehälter geworfen werden.
4. Mischen Sie keine unterschiedlichen Batterietypen im Gerät. Unterschiedliche Batterietypen oder neue und gebrauchte Batterien dürfen nicht gemischt werden.
5. Benötigt 1,5-V-AA-Batterien. 1.5 V + × 3
Nicht wiederaufladbare Batterien dürfen nicht aufgeladen werden.
7. Wiederaufladbare Batterien dürfen nur unter Aufsicht von Erwachsenen aufgeladen werden.
8. Wiederaufladbare Batterien müssen vor dem Laden aus dem Produkt entfernt werden.
9. Batterien sind entsprechend der im Batteriefach angezeigten Polarität einzulegen. Batterien müssen mit der richtigen Polarität (+ und -) eingesetzt werden.
10. Bei Bedarf Batterien aus dem Ladegerät entfernen.
11. Die Stromversorgung sollte weiterhin mit dem Batteriefach verbunden bleiben.
12. Mischen Sie keine alten und neuen Batterien.
13. Mischen Sie keine alkalischen, Standard- (Kohle-Zink-) oder wiederaufladbaren (Nickel-Cadmium-) Batterien.
14. Die Versorgungsklemmen dürfen nicht kurzgeschlossen werden.
15. Entleerte Batterien sind aus dem Spielzeug zu entfernen.

Wartung & Pflege

1. Reinigen Sie die Oberfläche häufig mit einem weichen Tuch.
2. Vermeiden Sie direkte Sonneneinstrahlung.
3. Alle Befestigungselemente müssen regelmäßig überprüft und gewartet werden.
4. Überprüfen Sie den Batteriestatus häufig. Lagern Sie die Batterie ordnungsgemäß für die zukünftige Verwendung.
5. Mit Vorsicht handhaben.

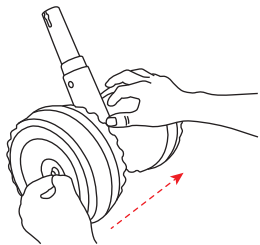

7. Am anderen Ende der Eisenstange (G) nacheinander ein Rad (F) und eine Unterlegscheibe (M) aufschieben und dann einen Stift (J) in das Loch am Ende der Eisenstange einführen.

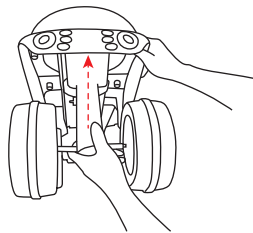

8. Führen Sie das obere Ende der Lenkwelle (D) durch die vordere Unterseite des Hauptkörpers (A) und schieben Sie es durch den Hauptkörper.

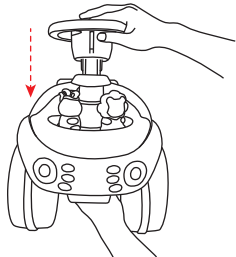

9. Schieben Sie das Lenkrad (B) auf das obere Ende der Lenkwelle und richten Sie die Löcher auf beiden Seiten aus.

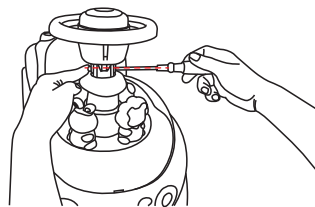

10. Führen Sie die Gewindestange (I) in das Seitenloch des Lenkrads (B) ein, führen Sie sie durch die Löcher des Lenkrads und der Lenkwelle und sichern Sie sie anschließend mit einer Mutter.

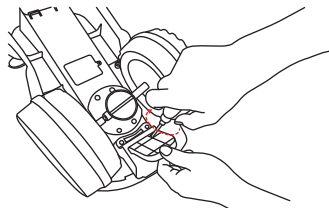

11. Bringen Sie die Kippsicherungen (H) an den in der Abbildung gezeigten Positionen an und befestigen Sie jede an zwei Stahlnägeln (K).

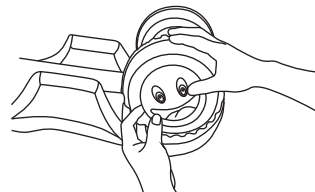

12. Richten Sie die Clips der Radzierblenden (E) an den Schlitzen an der Außenseite der Räder aus und drücken Sie sie fest an. Wiederholen Sie diesen Vorgang für alle vier Radzierblenden.

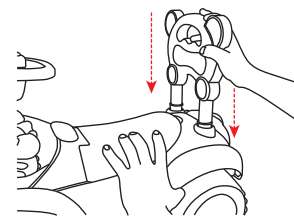

13. Stecken Sie die Rückenlehne (C) in das runde Loch an der Rückseite des Hauptkörpers, bis sie sicher einrastet.

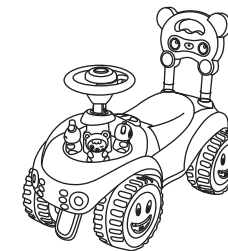

14. Die Montage ist nun abgeschlossen.

DIAGRAMM ZUM EINBAU UND AUSTAUSCH DER LENKRADBATTERIE

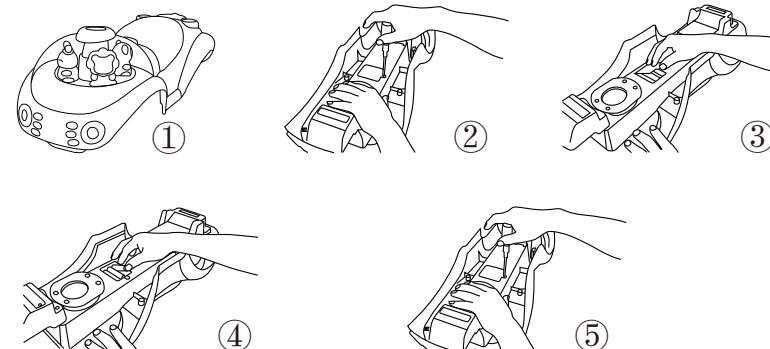

1. Die Batteriebox befindet sich auf der Unterseite des Gehäuses.
2. Verwenden Sie einen Schraubendreher, um die Schrauben zu lösen und die Abdeckung des Batteriefachs zu entfernen.
3. Entfernen Sie die Batterieabdeckung.
4. Installieren Sie 3 Stück 5AA-Batterien (1,5 V) und platzieren Sie diese gemäß den angezeigten Symbolen (+,-).
5. Schließen Sie die Abdeckung und ziehen Sie die Schrauben fest.
6. Um die Batterien zu entfernen, kehren Sie die Schritte 2 und 3 um.

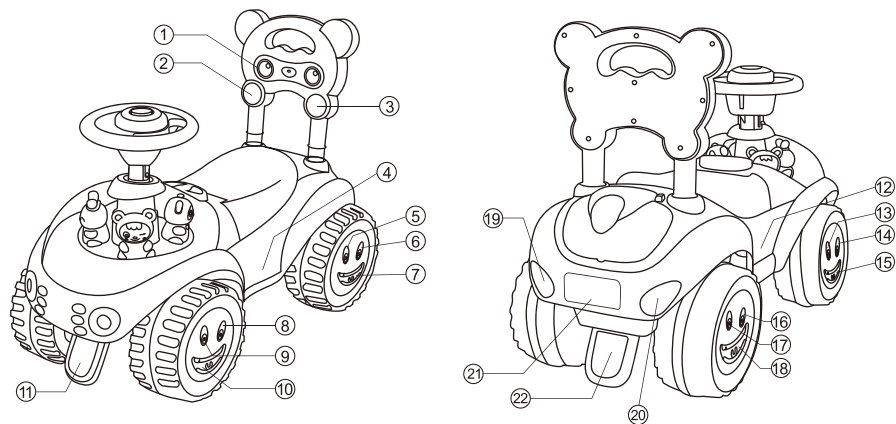

Elenco dei pezzi

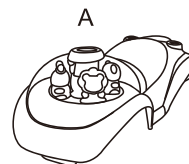

Carrozzeria x1



Volantino x1



Dossier x1



Albero di direzione x1



Copricerchi x4



Ruote x4

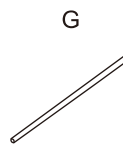

Barre di ferro x2



Supporta anti-ribaltamento x2



Barra filettata x1



Chiodi x2



Chiodi per muro in acciaio x4



Distanziali per ruota x2



Rondelle di vite x4

Schema di assemblaggio

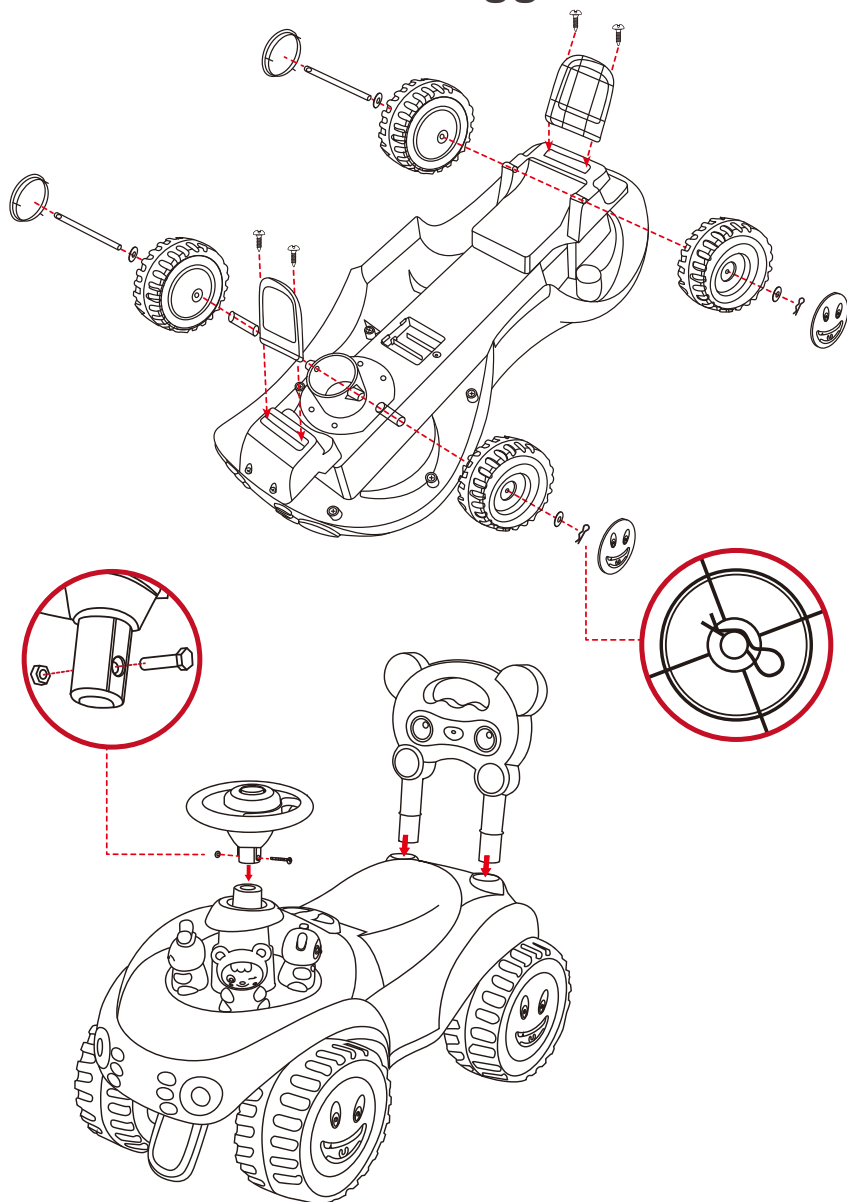

ATTENZIONE

1. Questo prodotto è adatto ai bambini fino a 18 mesi;
2. Questo prodotto può avere bordi affilati, punte o piccole parti potenzialmente pericolose prima del montaggio e deve essere assemblato da adulti;
3. I bambini dovrebbero montare questo su una superficie piana e liscia, e dovrebbero stare lontani dalla strada di circolazione; Vietato tassativamente in prossimità di veicoli a motore, strade, scale, pendii, colline, strade, vicoli, piscine o altri luoghi con acqua;
4. Mantieni le quattro ruote a terra durante il gioco e non giocare su una pendenza superiore a 10°.
5. Questo prodotto deve essere utilizzato sotto la supervisione di adulti e indossare scarpe;
6. Questo prodotto è limitato a una sola persona, con una capacità di carico massima di 25 kg;
7. È necessario assemblare e installare tutte le parti da adulti.
8. Non lasciare che i bambini giochino da soli con questo prodotto per evitare il pericolo di caduta.
9. Il giocattolo deve essere utilizzato con cautela poiché è necessaria abilità per evitare cadute o collisioni che causino lesioni all'utente o a terzi.



ATTENZIONE

- Deve essere assemblato da un adulto e, nello stato non assemblato, può contenere bordi affilati potenzialmente pericolosi, punte taglienti o piccole parti.
- Questo giocattolo produce lampi che possono scatenare l'epilessia nelle persone sensibili.

Istruzioni di montaggio

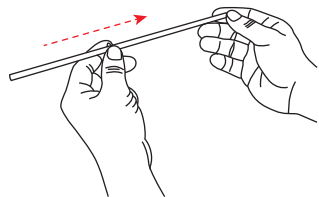

1. Posizionare una rondella (M) sulla barra di ferro (G).

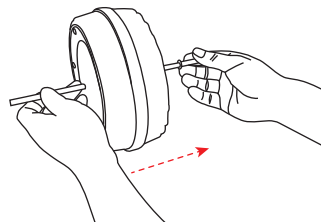

2. Quindi, far scorrere una ruota (F) sulla stessa estremità della barra di ferro (G).

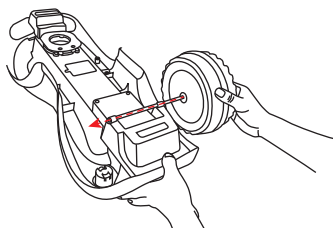

3. Inserire la barra di ferro (G) attraverso il foro corrispondente e attraverso la base posteriore del corpo principale (A).

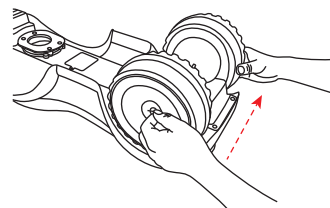

All'altra estremità dell'asta di ferro (G), infilare in sequenza una ruota (F) e una rondella (M), quindi inserire un perno (J) nel foro all'estremità dell'asta di ferro.

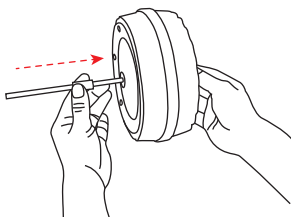

5. Inserire in sequenza una rondella (M), una ruota (F) e un distanziale per ruota (L) sull'asta di ferro (G).

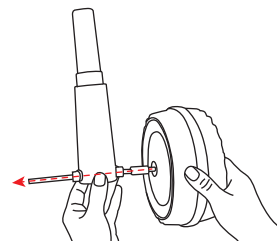

6. Inserire la barra di ferro (G) attraverso il foro corrispondente e farla passare attraverso l'albero di sterzo (D).

Precauzioni per l'installazione delle batterie

1. I bambini devono essere supervisionati dagli adulti quando si utilizzano le batterie.
2. Tenere gli strumenti di montaggio fuori dalla vista e dalla portata dei bambini.
3. Le batterie AA che perdono non sono più funzionanti e devono essere smaltite correttamente nei contenitori per rifiuti.
4. Non mescolare tipi diversi di batterie nell'apparecchio.
Non mescolare batterie di tipo diverso o batterie nuove e usate.
5. Richiede batterie AA da 1,5 V. 1.5 V + × 3
Le batterie non ricaricabili non devono essere ricaricate.
7. Le batterie ricaricabili devono essere caricate solo sotto la supervisione di adulti.
8. Le batterie ricaricabili devono essere rimosse dal prodotto prima della ricarica.
9. Le batterie devono essere inserite secondo la polarità indicata nel vano batteria. Le batterie devono essere inserite con la polarità corretta (+ e -).
10. Se necessario, rimuovere le batterie dal caricabatterie.
11. L'alimentazione elettrica dovrebbe rimanere collegata al vano batteria.
12. Non mescolare batterie vecchie e nuove.
13. Non mescolare batterie alcaline, standard (carbone-zinco) o ricaricabili (nichel-cadmio).
14. I terminali di alimentazione non devono essere cortocircuitati.
15. Le batterie scariche devono essere rimosse dal giocattolo.

Manutenzione e cura

1. Pulire frequentemente la superficie con un panno morbido.
2. Evitare l'esposizione diretta alla luce solare.
3. Tutti gli elementi di fissaggio devono essere controllati e mantenuti regolarmente.
4. Controllare frequentemente lo stato della batteria. Conservare la batteria in modo appropriato per un uso futuro.
5. Maneggiare con cautela.

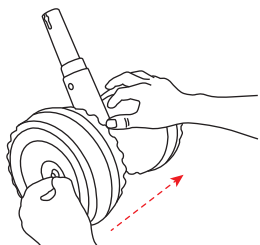

7. Inserire in sequenza una ruota (F) e una rondella (M) sull'estremità dell'asta di ferro (G) e poi infilare un perno (J) nel foro all'estremità dell'asta di ferro.

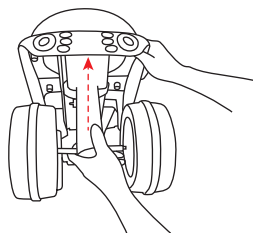

8. Far passare l'estremità superiore dell'albero dello sterzo (D) attraverso la parte inferiore anteriore del corpo principale (A) e spingerlo attraverso il corpo principale.

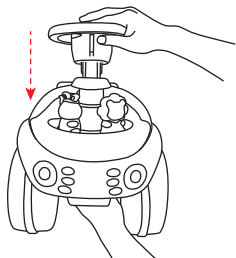

9. Far scorrere il volante (B) sulla parte superiore dell'albero dello sterzo e allineare i fori su entrambi i lati.

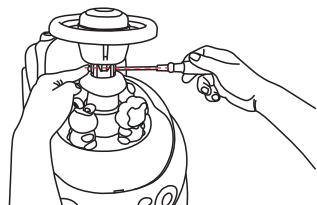

10. Inserire la barra filettata (I) nel foro laterale del volante (B), farla passare attraverso i fori del volante e dell'albero dello sterzo e quindi fissarla con un dado.

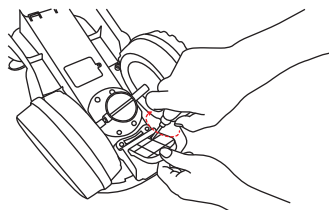

11. Posizionare le protezioni anti-ribaltamento (H) nelle posizioni indicate nella figura e fissare ciascuna con due chiodi d'acciaio (K).

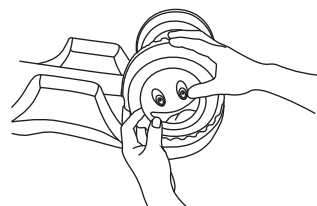

12. Allineare i fermi dei coprirota (E) con le fessure sul lato esterno delle ruote e premere saldamente. Ripetere l'operazione per tutti e quattro i coprirota.

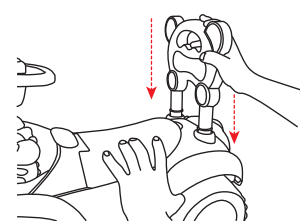

13. Inserire lo schienale (C) nel foro rotondo sul retro del corpo principale fino a quando non scatta in posizione in modo sicuro.

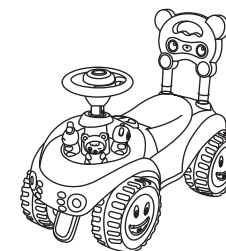

14. L'assemblaggio è ora completato.

DIAGRAMMA PER L'INSTALLAZIONE E LA SOSTITUZIONE DELLA BATTERIA DEL VOLANTE

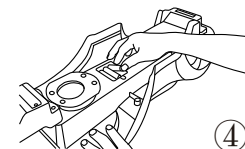
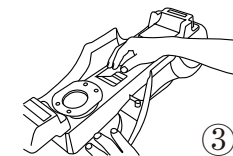
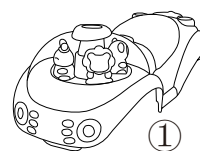

1. La scatola della batteria si trova sulla parte inferiore dell'alloggiamento.
2. Utilizzare un cacciavite per allentare le viti e rimuovere il coperchio del vano batteria.
3. Rimuovere il coperchio della batteria.
4. Installare 3 batterie 5AA (1,5 V) e posizionarle secondo i simboli indicati (+, -).
5. Chiudere il coperchio e serrare le viti.
6. Per rimuovere le batterie, invertire i passaggi 2 e 3.

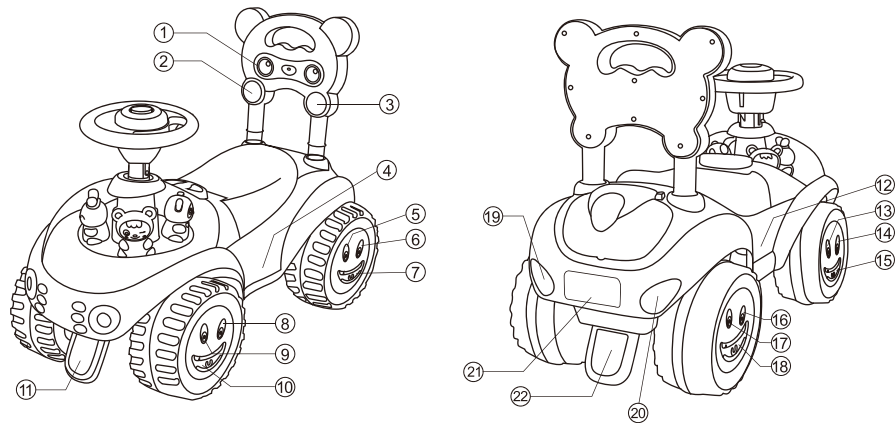

Lista de piezas

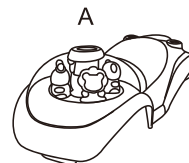

Carrocería x1



Volante x1



Dossier x1



Árbol de dirección x1



Tapacubos x4



Ruedas x4

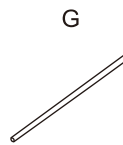

Barra de hierro x2



Soportes anti-vuelco x2

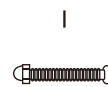

Varilla roscada x1



Clavos x2



Clavos para pared de acero x4



Separadores para rueda x2



Arandelas de vida x4

Esquema de montaje

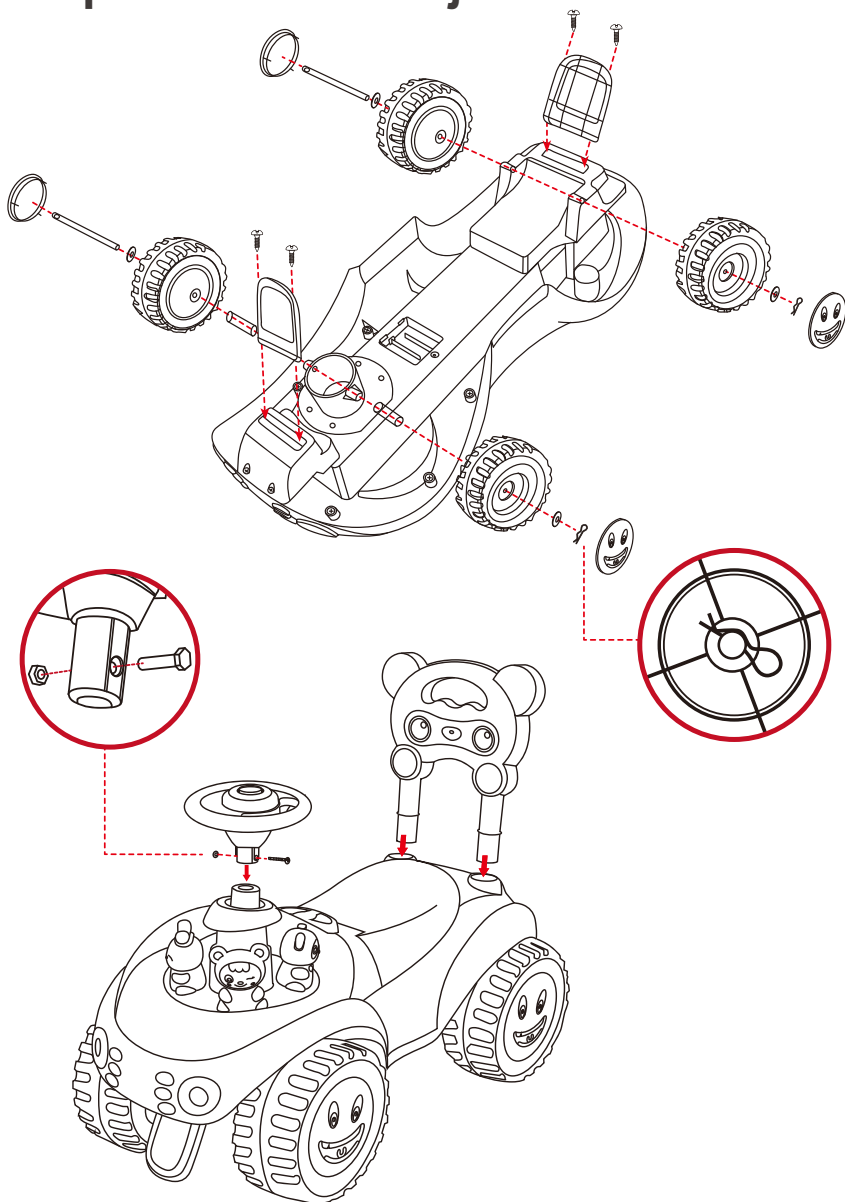

ATENCIÓN

1. Este producto es adecuado para niños hasta los 18 meses;
2. Este producto puede tener bordes afilados, puntas o pequeñas partes potencialmente peligrosas antes del montaje y debe ser ensamblado por adultos;
3. Los niños deben montar esto sobre una superficie plana y lisa, y deben mantenerse alejados de las vías de circulación; Está estrictamente prohibido cerca de vehículos motorizados, carreteras, escaleras, pendientes, colinas, calles, callejones, piscinas u otros lugares con agua;
4. Mantén las cuatro ruedas en el suelo durante el juego y no juegues en una pendiente superior a 10°.
5. Este producto debe utilizarse bajo la supervisión de adultos y con calzado puesto;
6. Este producto está limitado a una sola persona, con una capacidad máxima de carga de 25 kg;
7. Es necesario ensamblar e instalar todas las piezas por parte de adultos.
8. No permita que los niños jueguen solos con este producto para evitar el peligro de caídas.
9. El juguete debe usarse con precaución ya que se requiere habilidad para evitar caídas o colisiones que puedan causar lesiones al usuario o a terceros.



ATENCIÓN

- Debe ser ensamblado por un adulto y, en estado no ensamblado, puede contener bordes afilados potencialmente peligrosos, puntas cortantes o piezas pequeñas.
- Este juguete produce destellos que pueden desencadenar epilepsia en personas sensibles.

Instrucciones de montaje

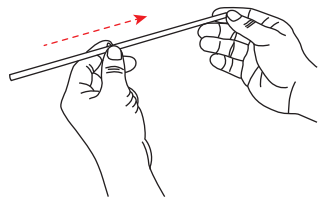

1. Colocar una arandela (M) sobre la barra de hierro (G).

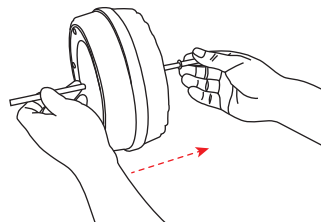

2. A continuación, deslice una rueda (F) sobre el mismo extremo de la barra de hierro (G).

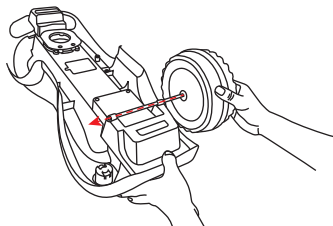

3. Insertar la barra de hierro (G) a través del orificio correspondiente y por la base trasera del cuerpo principal (A).

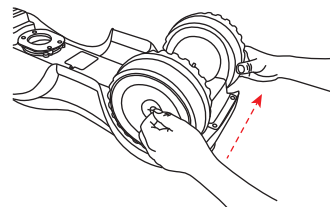

En el otro extremo de la varilla de hierro (G), ensartar en secuencia una rueda (F) y una arandela (M), luego insertar un pasador (J) en el agujero del extremo de la varilla de hierro.

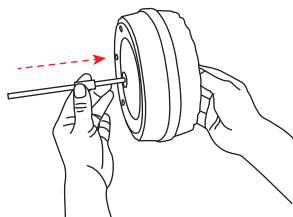

5. Insertar en secuencia una arandela (M), una rueda (F) y un separador de rueda (L) en la barra de hierro (G).

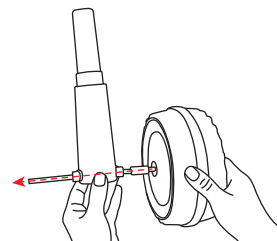

6. Introduzca la barra de hierro (G) por el orificio correspondiente y pásela a través del eje de dirección (D).

Precauciones para la instalación de las baterías

1. Los niños deben ser supervisados por adultos cuando utilizan las batería.
2. Mantener las herramientas de montaje fuera de la vista y del alcance de los niños.
3. Las pilas AA que presentan fugas ya no funcionan y deben ser Depositado correctamente en los contenedores de residuos.
4. No mezcle diferentes tipos de pilas en el dispositivo.
No mezcle pilas de diferente tipo o pilas nuevas y usadas.
5. Requiere pilas AA de 1,5 V. 1.5 V + × 3
6. Las pilas no recargables no deben recargarse.
7. Las baterías recargables solo deben cargarse bajo la supervisión de un adulto.
8. Las baterías recargables deben extraerse del producto antes de cargarlas.
9. Las baterías deben insertarse según la polaridad indicada en el compartimento de las mismas. Las baterías deben colocarse con la polaridad correcta (+ y -).
10. Si es necesario, retire las baterías del cargador.
11. La alimentación eléctrica debe permanecer conectada al compartimiento de la batería.
12. No mezcle baterías viejas y nuevas.
13. No mezcles pilas alcalinas, estándar (carbón-zinc) o recargables (níquel-cadmio).
14. Los terminales de alimentación no deben cortocircuitarse.
15. Las pilas agotadas deben retirarse del juguete.

Mantenimiento y cuidado

1. Limpiar frecuentemente la superficie con un paño suave.
2. Evitar la exposición directa a la luz solar.
3. Todos los elementos de fijación deben ser revisados y mantenidos regularmente.
4. Verificar con frecuencia el estado de la batería. Almacenar la batería adecuadamente para su uso futuro.
5. Manipular con precaución.

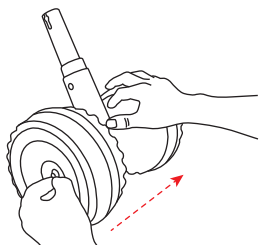

7. Insertir en secuencia una rueda (F) y una arandela (M) en el extremo de la varilla de hierro (G) y luego introducir un pasador (J) en el agujero del extremo de la varilla de hierro.

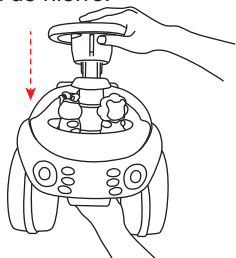

9. Deslizar el volante (B) sobre la parte superior del eje de la dirección y alinear los orificios en ambos lados.

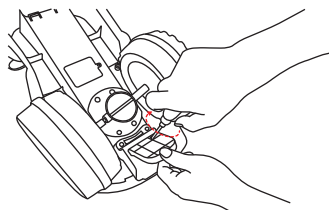

11. Coloque las protecciones anti-vuelco (H) en las posiciones indicadas en la figura y fije cada una con dos clavos de acero (K).

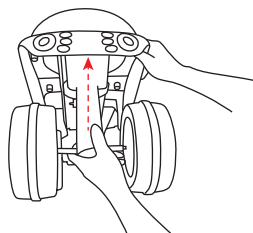

8. Hacer pasar el extremo superior del árbol de la... Esterza (D) a través de la parte inferior frontal del cuerpo principal (A) y empujalo a través del cuerpo principal.

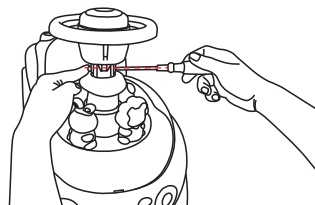

10. Inserte la barra roscada (I) en el orificio lateral del volante (B), pásela a través de los orificios del volante y del eje de dirección y luego fíjela con una tuerca.

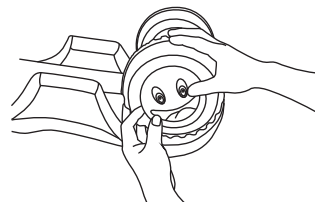

12. Alinear los cierres de las tapas de rueda (E) con las ranuras en el lado exterior de las ruedas y presionar firmemente. Repetir la operación para las cuatro tapas de rueda.

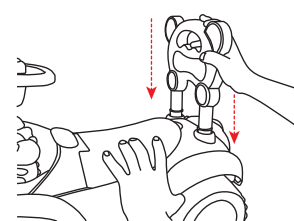

13. Inserte el respaldo (C) en el orificio redondo en la parte trasera del cuerpo principal hasta que encaje de forma segura.

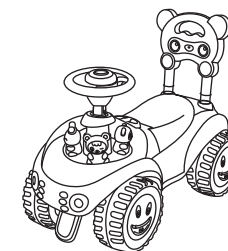

14. El ensamblaje ya está completo.

DIAGRAMA PARA LA INSTALACIÓN Y REEMPLAZO DE LA BATERÍA DEL VOLANTE

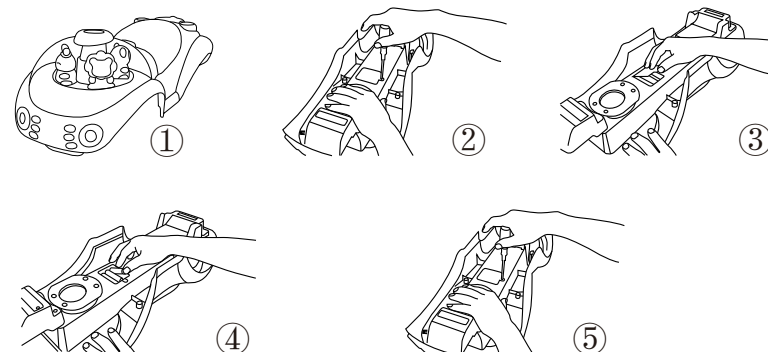

1. La caja de la batería se encuentra en la parte inferior de la carcasa.
2. Utilice un destornillador para aflojar los tornillos y retirar la tapa del compartimento de la batería.
3. Retire la tapa de la batería.
4. Instale 3 baterías AA de 1,5 V y colóquelas según los símbolos indicados (+, -).
5. Cierre la tapa y apriete los tornillos.
6. Para retirar las baterías, invertir los pasos 2 y 3.