

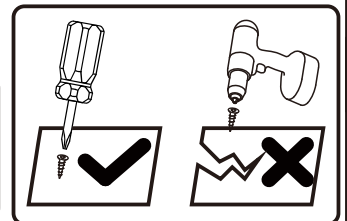
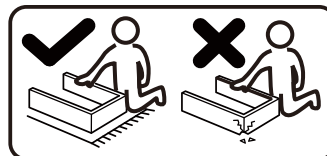
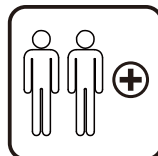
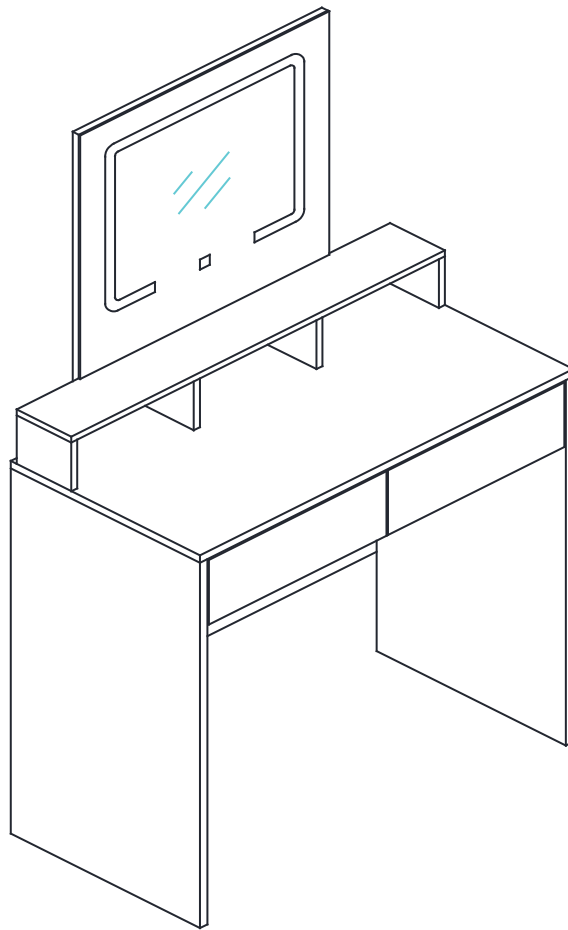

IN240700811V01

**831-924V81**

Tools Recommended

**EN\_ IMPORTANT, RETAIN FOR FUTURE REFERENCE: READ CAREFULLY.**

**FR\_ IMPORTANT: A LIRE ATTENTIVEMENT ET À CONSERVER POUR CONSULTATION ULTÉRIEURE.**

**ES\_ IMPORTANTE, LEA Y GUARDE PARA FUTURAS REFERENCIAS.**

**PT\_ IMPORTANTE: LEIA ATENTAMENTE E GUARDE PARA CONSULTA FUTURA.**

**DE\_ WICHTIG! SORGFÄLTIG LESEN UND FÜR SPÄTER NACHSCHLAGEN AUFBEWAHREN.**

**IT\_ IMPORTANTE! CONSERVARE IL PRESENTE MANUALE PER FUTURO RIFERIMENTO E LEGGERLO ATTENTAMENTE.**

**RO\_ IMPORTANT: CITIȚI CU ATENȚIE ȘI PĂSTRAȚI PENTRU CONSULTARE VIITOARE.**



**EN\_ QUICKFIT:** Tighten quickfit until shoulder is flush with panel. Do not overtighten or undertighten.

**FR\_ RACCORD RAPIDE:** Faites serrer le raccord rapide jusqu'à ce que l'épaulement soit parfaitement encastré dans le panneau. Il ne faut ni trop serrer ni insuffisamment serrer.

**ES\_ QUICKFIT:** Apriete quickfit hasta que el hombro se descargue con el panel. NO lo sobreapriete ni lo apriete poco.

**PT\_ AJUSTE RÁPIDO:** Aperte o ajuste rápido até estar nivelada com o painel. Não apertar demasiado ou excessivamente.

**DE\_ QUICKFIT:** Ziehen Sie den Quickfit fest, bis die Schulter mit der Platte bündig ist. Bitte nicht zu fest oder zu schwach anziehen.

**IT\_ MONTAGGIO RAPIDO:** Stringere il montaggio rapido fino a quando la spalla è a filo con il pannello, non stringere troppo o troppo poco.

**RO\_ QUICKFIT:** Strângeți quickfit până când umărul este la același nivel cu panoul. Nu strângeți prea tare și nici prea slab.



**EN\_ CAM LOCK:** When fitting cam lock, ensure starting position is correct before you insert connecting quickfit.

**FR\_ SERRURE BATTEUSE:** Avant d'insérer la serrure batteuse, veillez à la bonne orientation avant d'insérer le raccord rapide.

**ES\_ CIERRE DE LA CÁMARA:** Cuando instale el cierre de la cámara, asegúrese de que la posición de inicio es correcta antes de que inserte el quickfit conector.

**PT\_ BLOQUEIO:** Ao instalar o bloqueio, assegurar-se de que a posição inicial está correcta antes de inserir o encaixe de ligação rápida.

**DE\_ CAM-LOCK:** Achten Sie bei der Montage des Cam-Locks auf die richtige Ausgangsposition, bevor Sie den Quickfit einsetzen.

**IT\_ BLOCCAGGIO A CAMMA:** Quando si monta il bloccaggio a camma, assicurarsi che la posizione iniziale sia corretta prima di inserire il montaggio rapido di collegamento.

**RO\_ BLOCARE CU CAME:** Când montați blocarea cu came, asigurați-vă că poziția inițială este corectă înainte de a introduce racordul rapid.

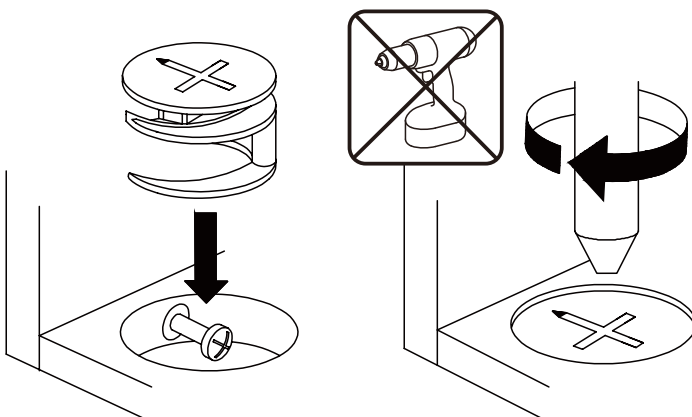

**EN\_ Turn cam lock clockwise to tighten.**

**FR\_ Faites tourner la serrure batteuse dans le sens des aiguilles d'une montre pour la resserrer.**

**ES\_ Gire el cierre de la cámara en sentido horario para apretarlo.**

**PT\_ Rodar o bloqueio no sentido dos ponteiros do relógio para o apertar.**

**DE\_ Drehen Sie den Cam-Lock im Uhrzeigersinn, um ihn festzuziehen.**

**IT\_ Ruotare il bloccaggio a camma in senso orario per stringere.**

**RO\_ Rotiți blocarea cu came în sensul acelor de ceasornic pentru a strânge.**

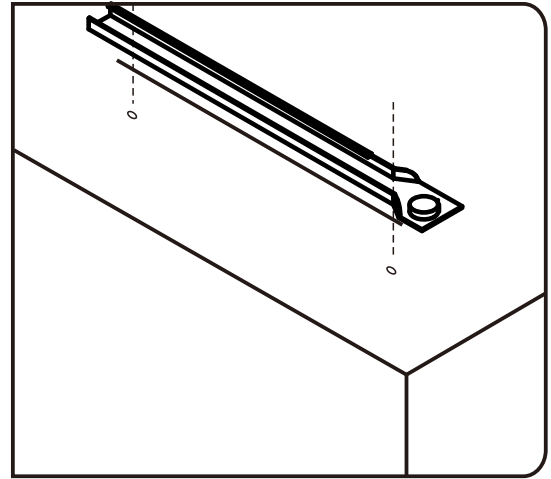
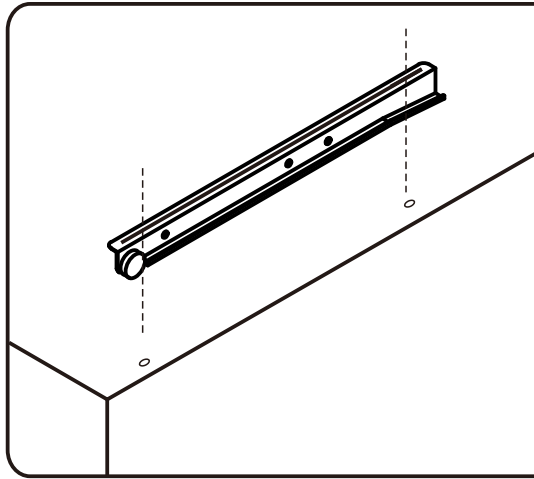
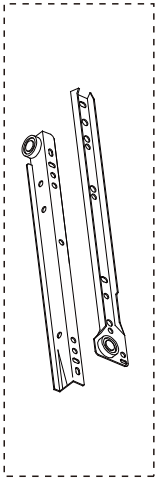

**EN\_** Please find the exact hole for installation, otherwise it will be misaligned. The screws on the drawer slide must be leveled, otherwise it will affect the smoothness of the drawer.

**FR\_** Identifiez le trou exact pour l'installation, sinon il sera mal aligné. Les vis de la glissière du tiroir doivent être nivelées, sinon cela affectera le fonctionnement du tiroir.

**ES\_** Al instalar, encuentre el orificio exacto; de lo contrario, estará desalineado. Los tornillos en las correderas del cajón deben estar nivelados, de lo contrario, afectará la suavidad al deslizar el cajón.

**PT\_** Por favor encontre o orifício exacto para instalação, caso contrário será desalinhado. Os parafusos na corredeira da gaveta devem ser nivelados, caso contrário afetará a suavidade da abertura da gaveta.

**DE\_** Bitte finden Sie das genaue Loch für die Installation, sonst wird es falsch ausgerichtet werden. Die Schrauben an der Schubladenführung müssen nivelliert werden, da sonst die Leichtgängigkeit der Schublade beeinträchtigt wird.

**IT\_** individuare il foro esatto per l'installazione, altrimenti ci sarà un disallineamento. Le viti sulla guida del cassetto devono essere allineate, altrimenti influirà sulla scorrevolezza del cassetto.

**RO\_** Găsiți orificiul exact pentru instalare, altfel acesta va fi aliniat incorect. Șuruburile de pe glisiera sertarului trebuie să fie nivelate, altfel aceasta va afecta funcționarea lină a sertarului.

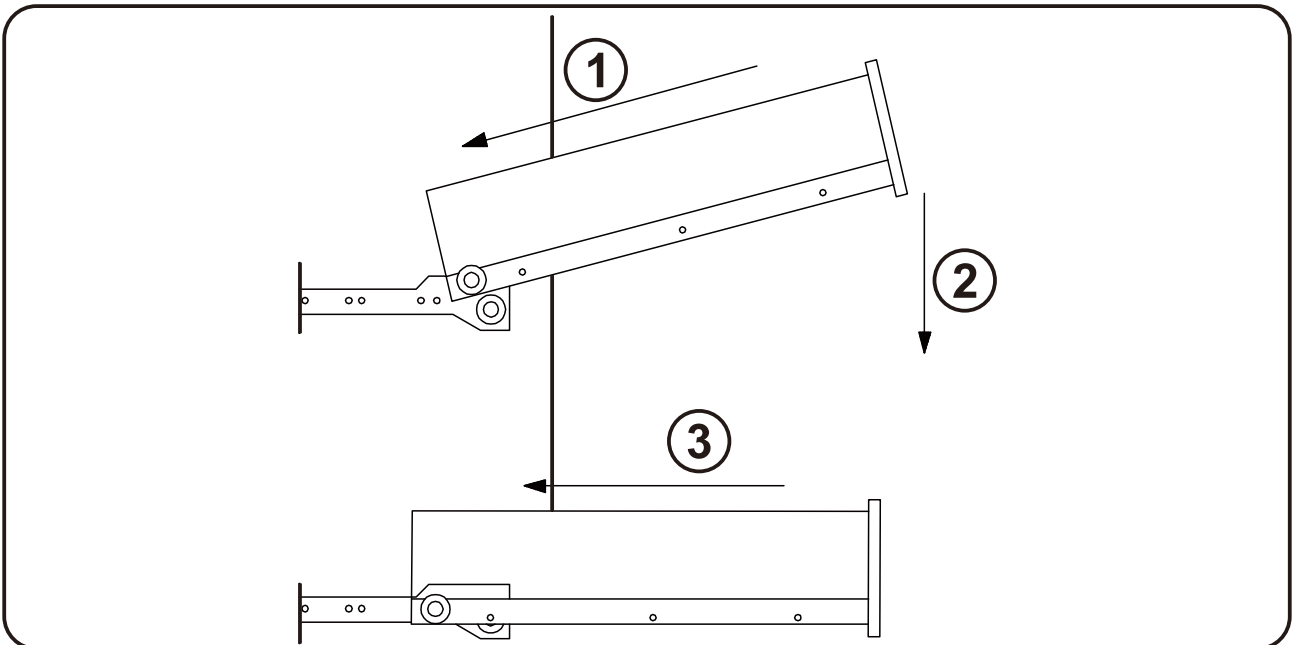

**EN\_** Be careful to push in the board when the both sides slide way been aligned.

**FR\_** Prenez soin d'enfoncer la planche lorsque les deux côtés de la glissière sont alignés.

**ES\_** Empuje con cuidado el tablero después de que los dos lados se hayan alineado.

**PT\_** Ter o cuidado de empurrar a placa quando os dois lados estiverem alinhados.

**DE\_** Achten Sie darauf, dass Sie die Platte einschieben, wenn die beiden Seiten so ausgerichtet sind, dass sie gleiten.

**IT\_** Fare attenzione quando si spinge il cassetto quando le due guide di scorrimento sono state allineate.

**RO\_** Aveți grijă să împingeți placa atunci când ambele părți sunt aliniate.

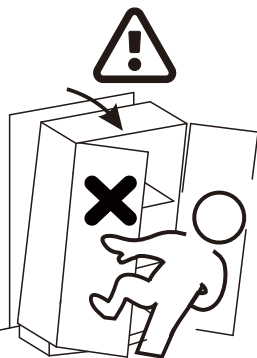
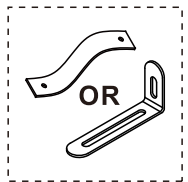

**EN\_** This is anti-dumping belt that fix the product to the wall and it can be used or not follow your needs.

**FR\_** Cette sangle anti-basculément permet de fixer le produit au mur. Elle peut être utilisée ou non selon vos besoins.

**ES\_** Esta es una correa anti-vuelco para fijar el producto a la pared, y según sus necesidades, puede utilizarla o no.

**PT\_** Este é o sistema anti-tombo que fixa o produto à parede e pode ser usado para uma maior segurança.

**DE\_** Dies ist Anti-Sturz-Gurt, um das Gerät an der Wand zu befestigen und es kann je nach Bedarf verwendet oder nicht verwendet werden.

**IT\_** Questa è una cintura anticaduta che fissa il prodotto alla parete e può essere utilizzata o meno a seconda delle vostre esigenze.

**RO\_** Aceasta este o centură anti-dumping care fixează produsul pe perete și poate fi utilizată sau nu, în funcție de necesități.

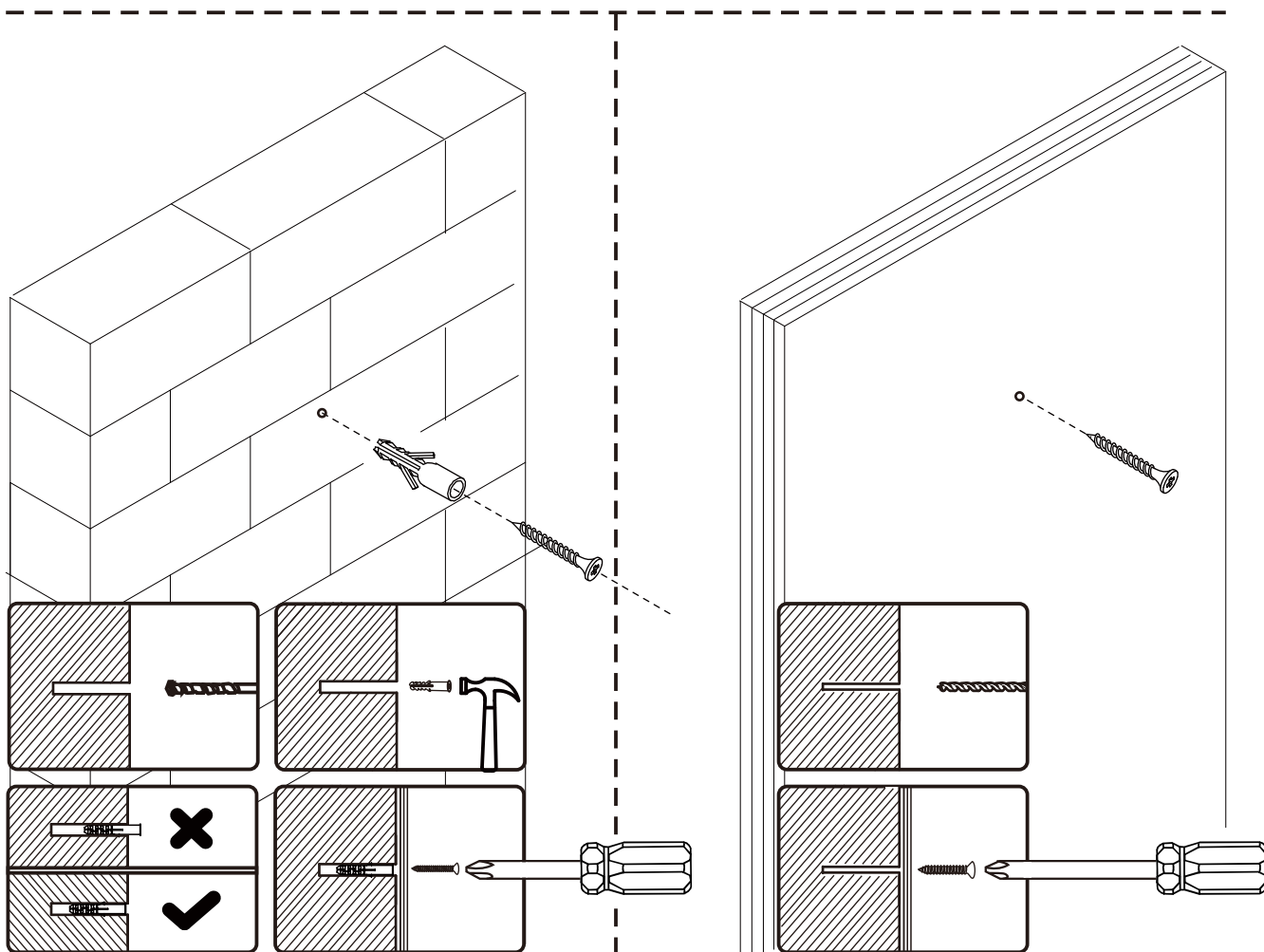

**EN\_** If it is a solid wall, please use expansion and self-tapping screws, if it is a wooden wall, only use self-tapping screws, please do not overtighten the screws

**FR\_** Si le mur est massif, veuillez utiliser des chevilles à expansion et des vis autotaraudeuses, mais s'il s'agit d'un mur en bois, utilisez uniquement des vis autotaraudeuses et ne serrez pas trop les vis.

**ES\_** Para una pared sólida, utilice los tornillos de expansión y autorroscantes. Para una pared de madera, utilice exclusivamente los tornillos autorroscantes, no los apriete demasiado.









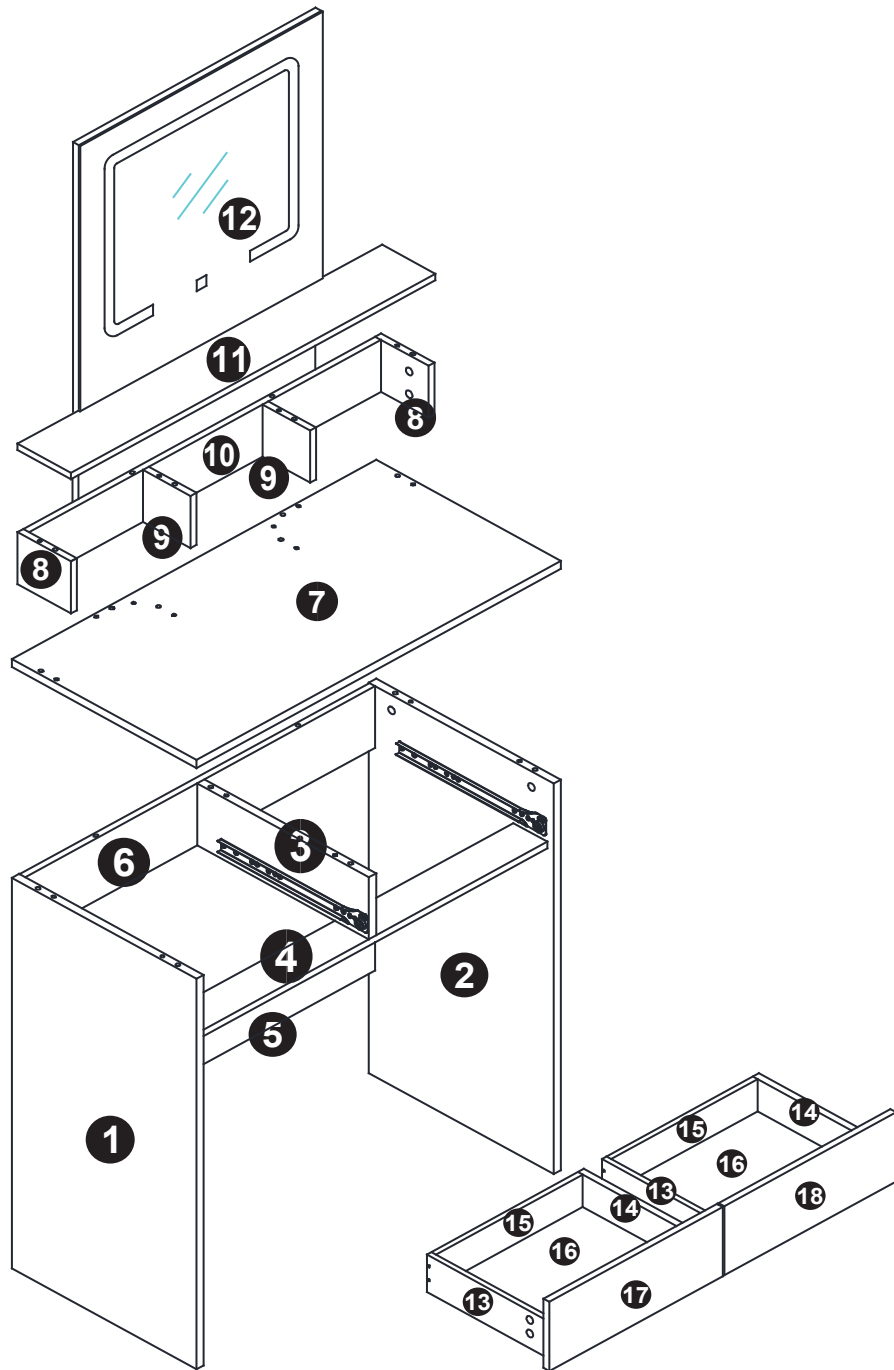

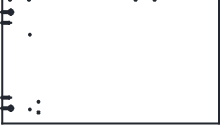
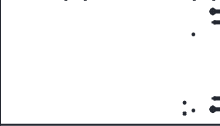





**PT\_** Se for uma parede sólida, use por favor parafusos de expansão e auto-roscantes, se for uma parede de madeira, use apenas parafusos auto-roscantes, por favor não aperte demasiado os parafusos.

**DE\_** Wenn es sich um eine Massivwand handelt, verwenden Sie bitte Dehnungs- und selbstschneidende Schrauben. Wenn es sich um eine Holzwand handelt, verwenden Sie nur selbstschneidende Schrauben, bitte ziehen Sie die Schrauben nicht zu fest an.

**IT\_** Se si tratta di un muro solido, utilizzare sia viti ad espansione che autofilettanti. Se si tratta di una parete in legno, utilizzare solo viti autofilettanti, non stringere eccessivamente le viti.

**RO\_** Dacă este un perete solid, vă rugăm să utilizați șuruburi cu expansiune și autofiletante, dacă este un perete din lemn, utilizați numai șuruburi autofiletante, vă rugăm să nu strângeți excesiv șuruburile.



 <b>1</b> x01	 <b>2</b> x01	 <b>3</b> x01
 <b>4</b> x01	 <b>5</b> x01	 <b>6</b> x01
 <b>7</b> x01	 <b>8</b> x02	 <b>9</b> x02
 <b>10</b> x01	 <b>11</b> x01	 <b>12</b> x01
 <b>13</b> x02	 <b>14</b> x02	 <b>15</b> x02
 <b>16</b> x02	 <b>17</b> x01	 <b>18</b> x01

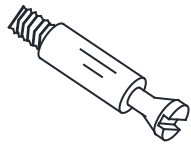

**A** x38  
 $\varnothing 7 \times 29$   
 +1 (spare)

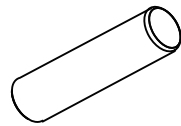

**B** x24  
 $\varnothing 6 \times 30$   
 +1 (spare)



**C** x38  
 $\varnothing 15 \times 10$   
 +1 (spare)



**P** x14  
 $M4 \times 30$   
 +1 (spare)



**Q** x04  
 $\varnothing 20 \times 0.5$   
 +1 (spare)

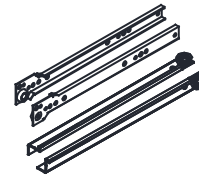

**Z** x02  
 12"

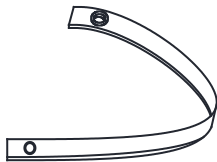

**R** x02  
 $L190 \times 13 \times 1$



**I** x18  
 $M3.5 \times 14$   
 +2 (spare)

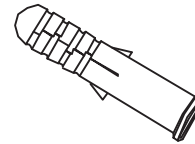

**K** x02  
 $M6 \times 30$



**O** x01

**A** x10



**I** x08



**B** x10



**Z** x02

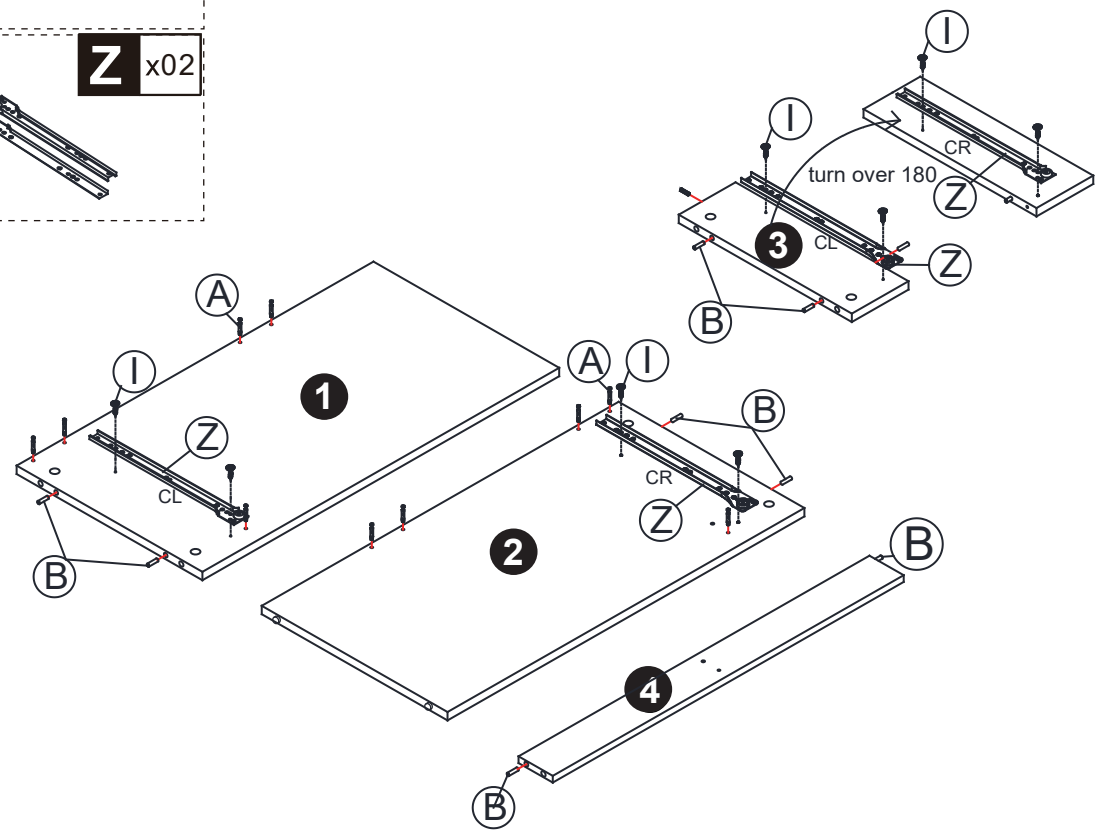
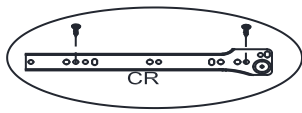
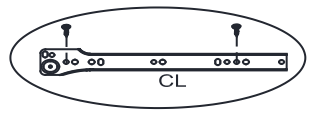

**P** x02

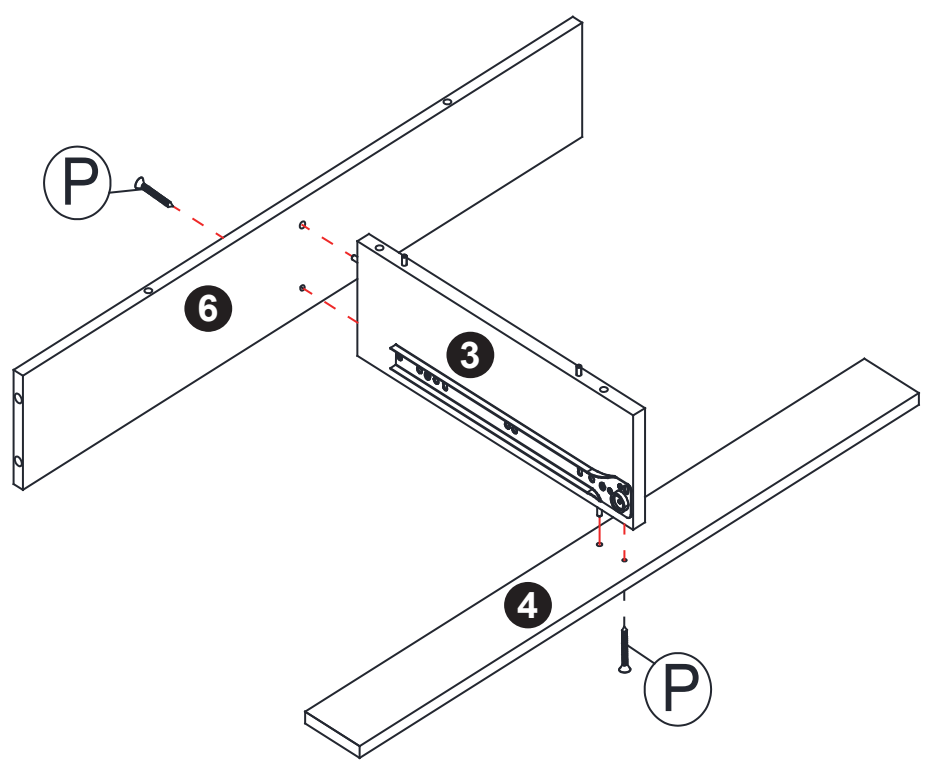

**C** x05

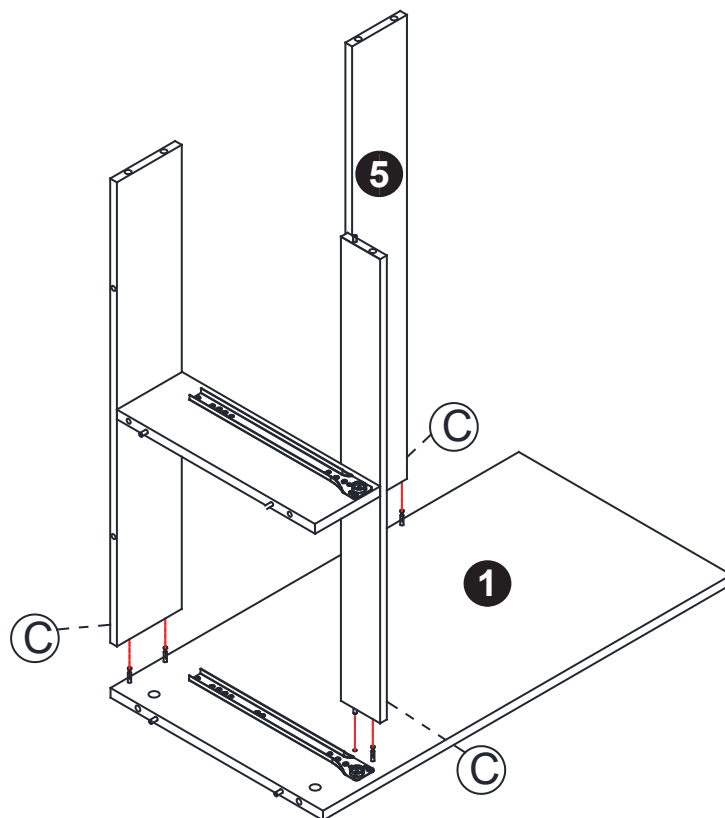

**C** x05

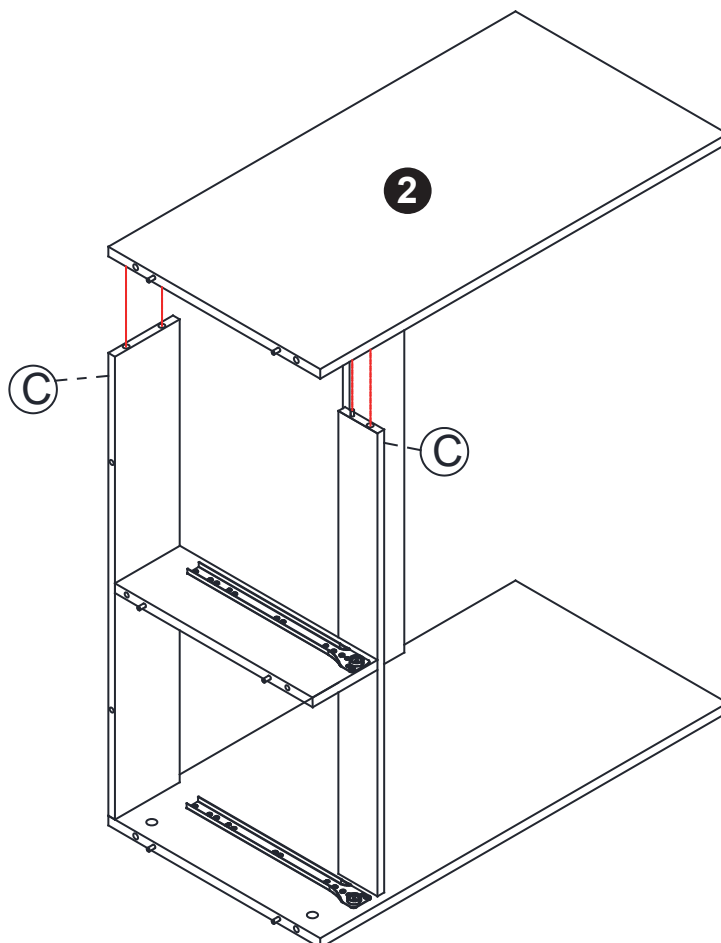

**A** x28



**B** x14

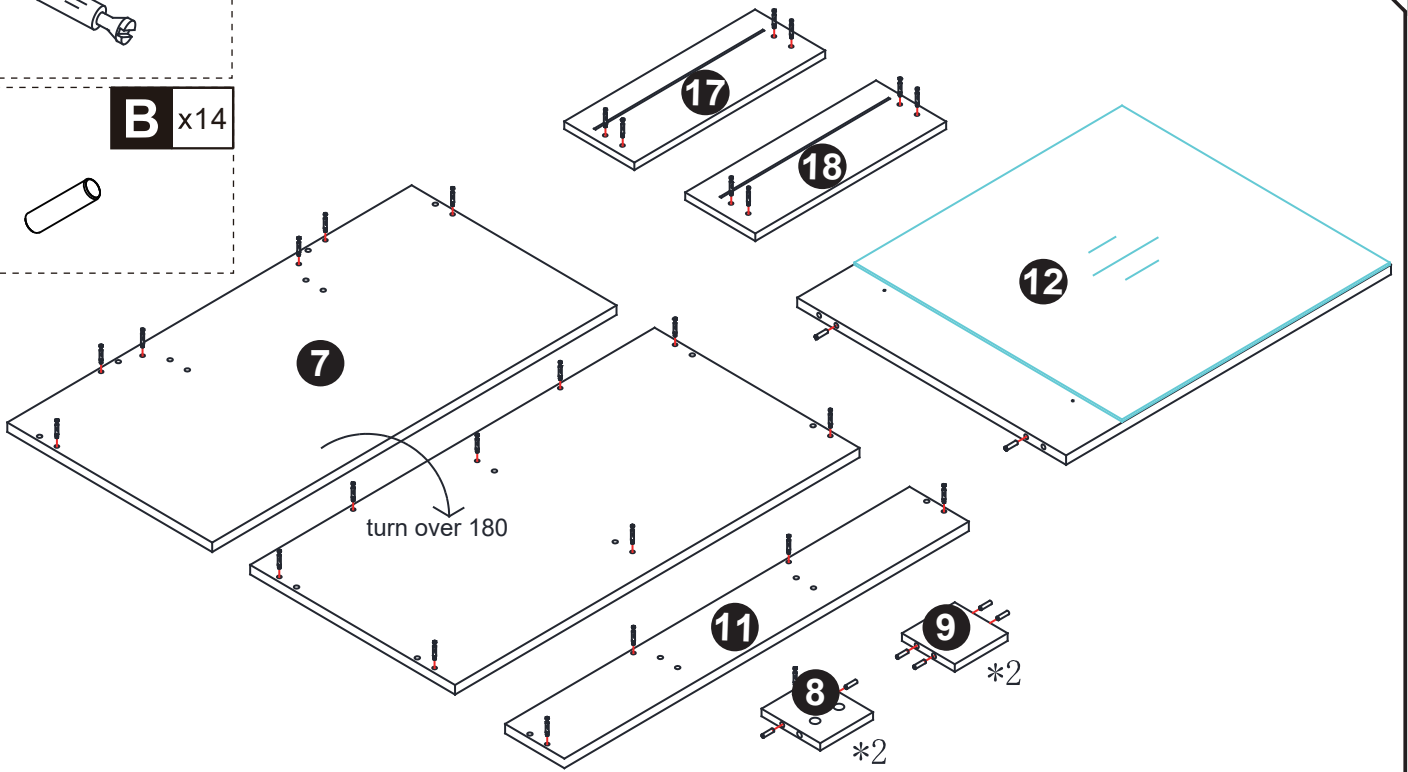

**C** x08

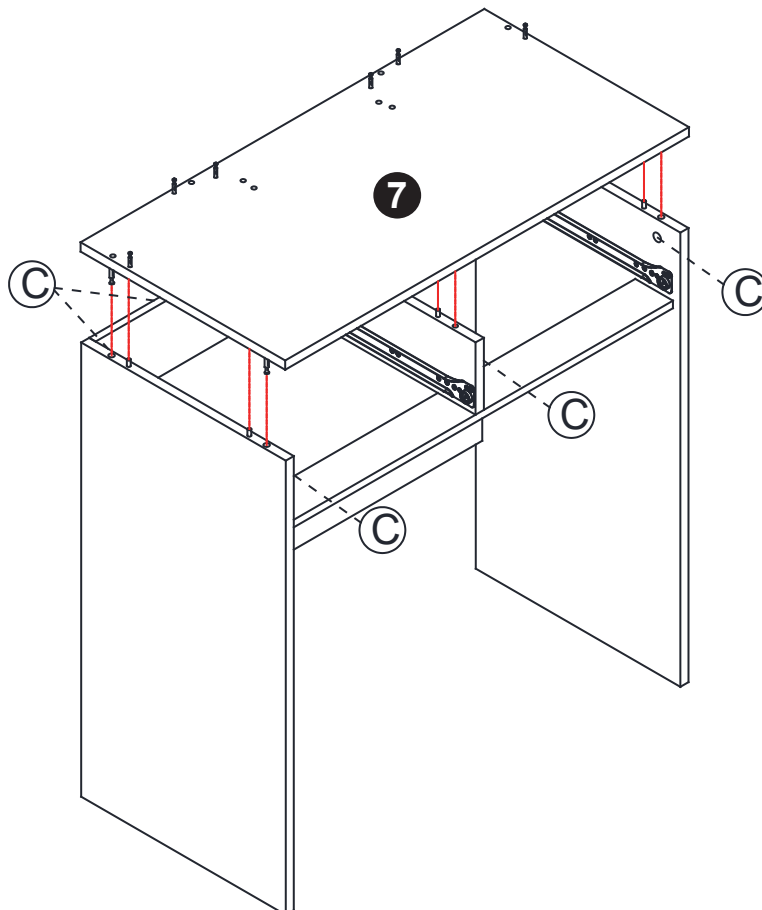

C x06

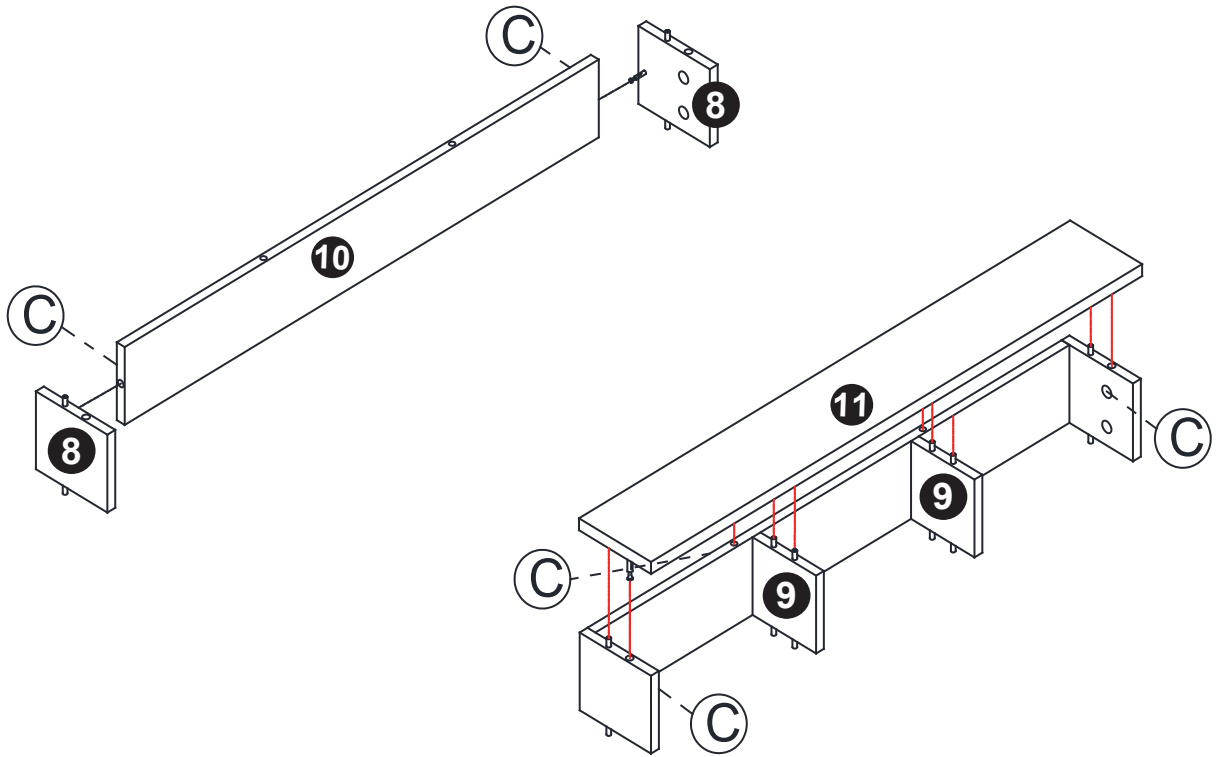

C x04

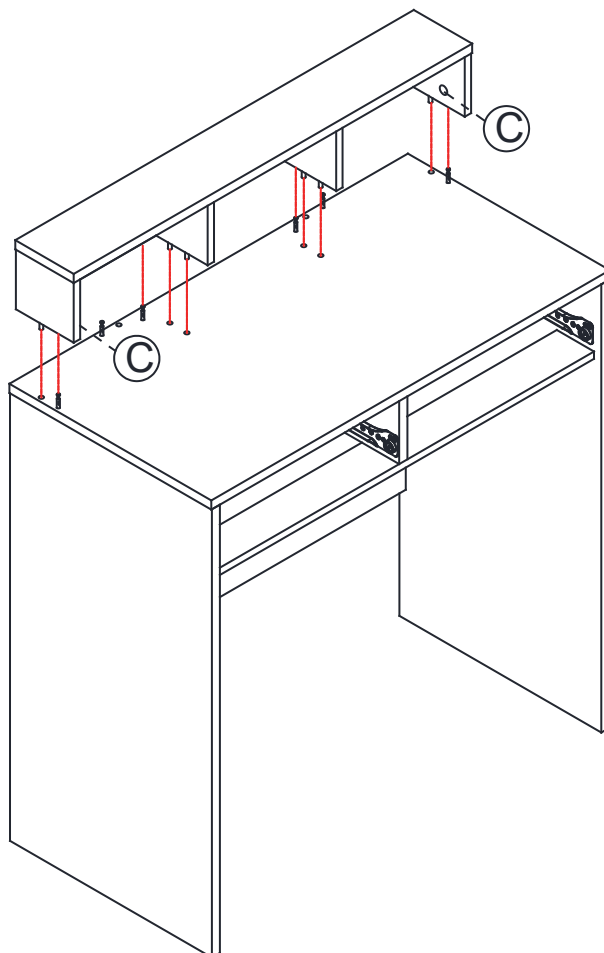

**C** x02

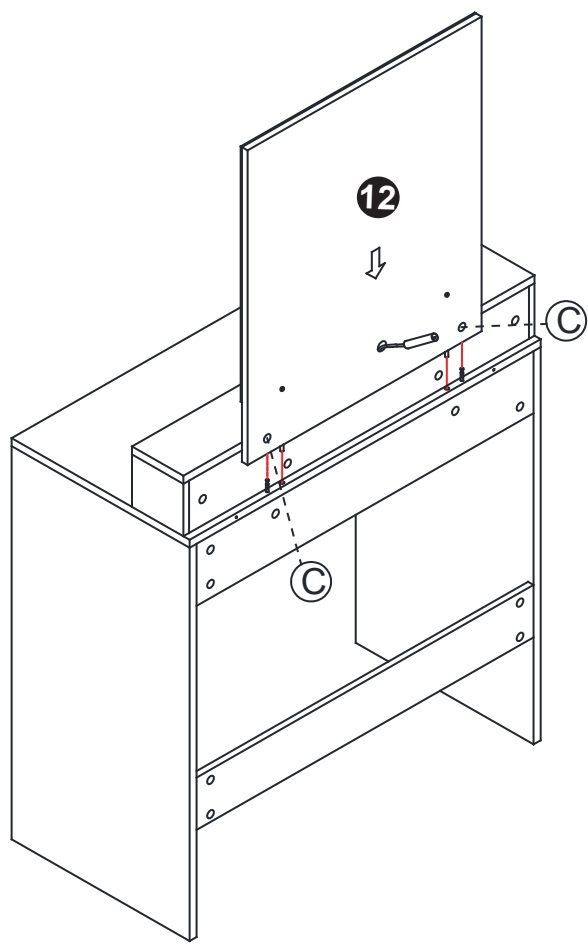

**P** x02



**I** x02



**R** x02



**O** x01

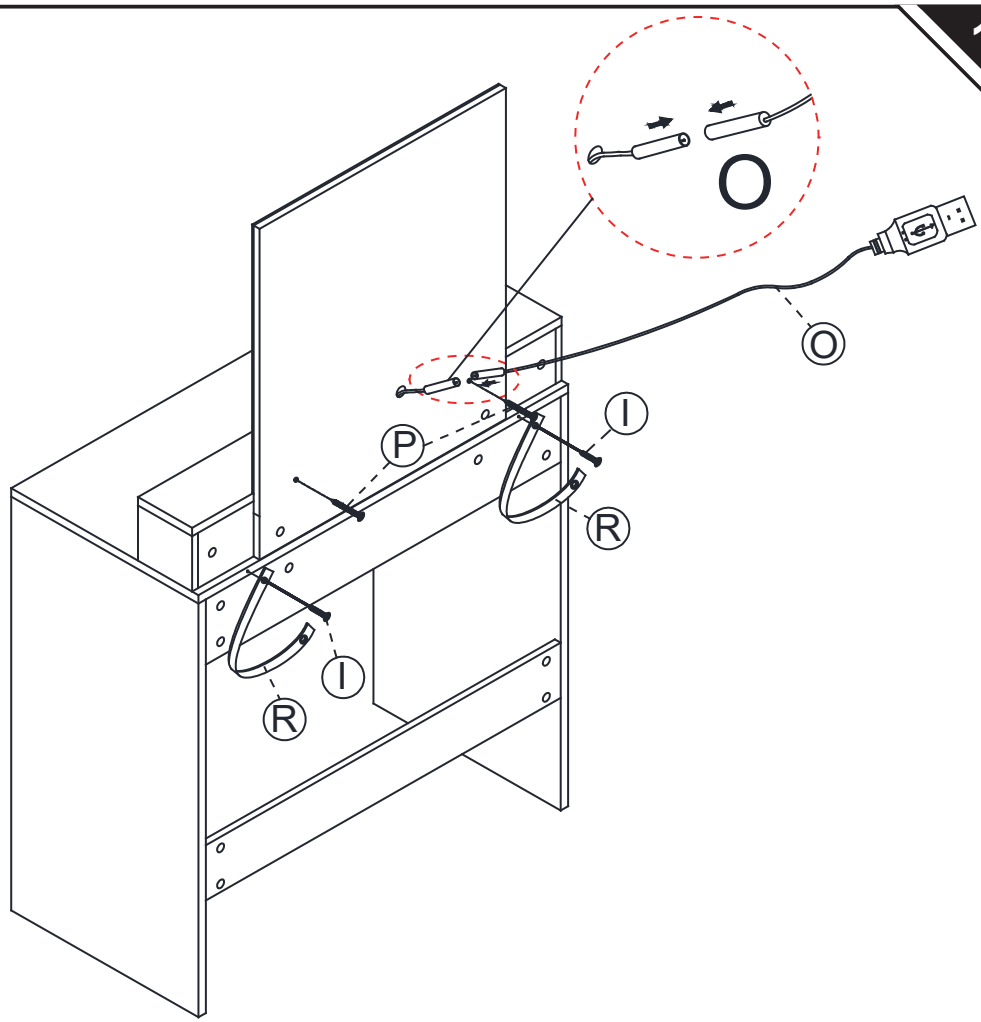



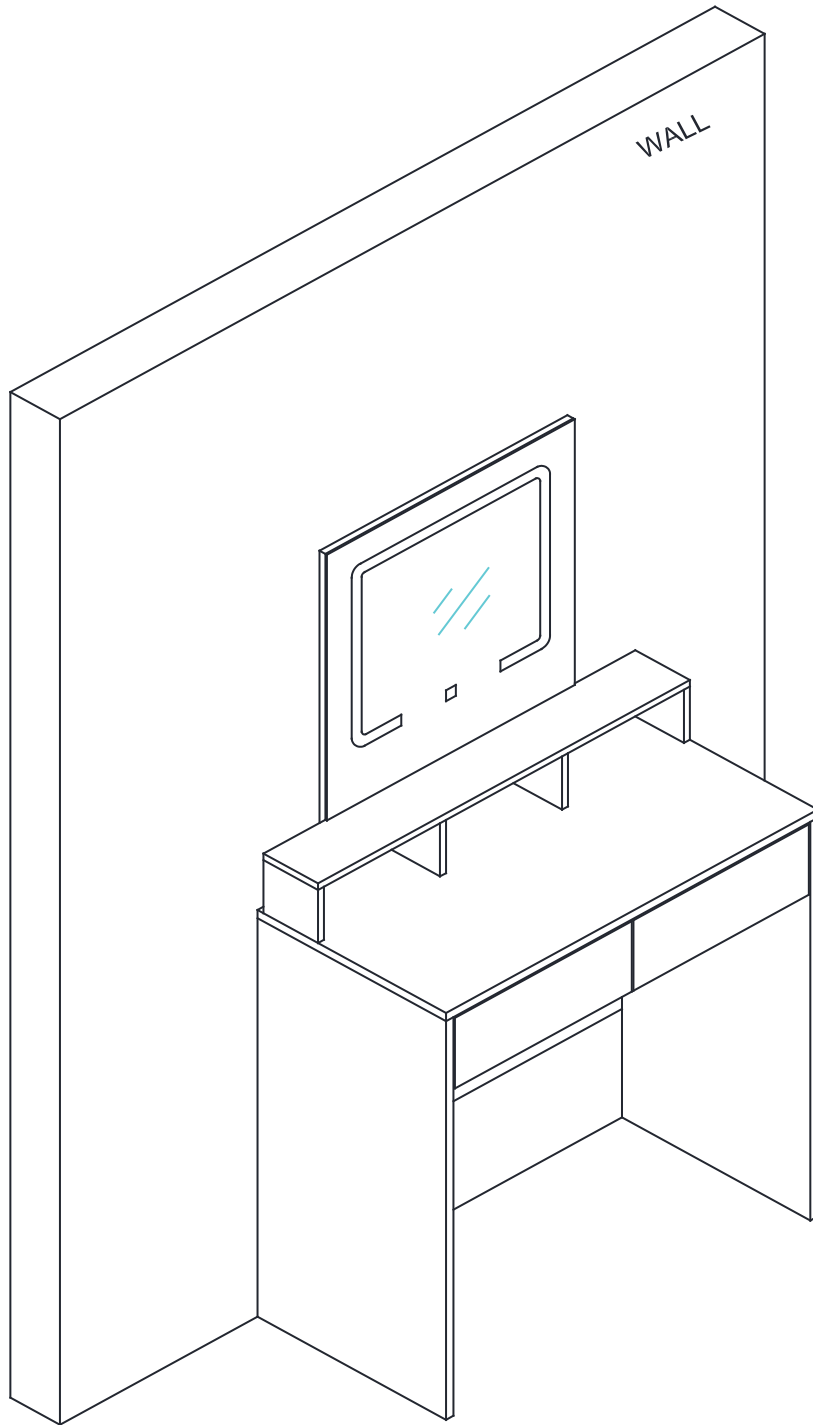

**INDOOR USE ONLY**

- **This product contains a light source of energy efficiency class <F>.**
- **The appliance must only be supplied at safety extra low voltage corresponding to the marking on the appliance.**
- To reduce the risk of strangulation the flexible wiring connected to this luminaire shall be effectively fixed to the wall if the wiring is within arm's reach.
- This appliance can be used by children aged from 8 years and above and persons with reduced physical, sensory or mental capabilities or lack of experience and knowledge if they have been given supervision or instruction concerning use of the appliance in a safe way and understand the hazards involved. Children shall not play with the appliance. Cleaning and user maintenance shall not be made by children without supervision.

**À USAGE INTÉRIEUR EXCLUSIVEMENT**

- **Ce produit contient une source lumineuse de classe d'efficacité énergétique <F>.**
- **L'appareil doit être alimenté uniquement sous la très basse tension de sécurité correspondant au marquage de l'appareil.**
- Pour réduire le risque d'étranglement, le câblage souple raccordé à ce luminaire doit être fixé efficacement au mur si le câblage se situe dans le volume d'accessibilité au toucher.
- Cet appareil peut être utilisé par des enfants âgés d'au moins 8 ans et par des personnes ayant des capacités physiques, sensorielles ou mentales réduites ou dénuées d'expérience ou de connaissance, s'ils (si elles) sont correctement surveillé(e)s ou si des instructions relatives à l'utilisation de l'appareil en toute sécurité leur ont été données et si les risques encourus ont été appréhendés. Les enfants ne doivent pas jouer avec l'appareil. Le nettoyage et l'entretien par l'utilisateur ne doivent pas être effectués par des enfants sans surveillance.

**NUR ZUR VERWENDUNG IN INNENRÄUMEN**

- **Dieses Produkt enthält eine Lichtquelle der Energieeffizienzklasse <F>.**
- **Das Gerät ist nur mit SELV entsprechend der Kennzeichnung auf dem Gerät zu versorgen.**
- Um die Gefahr einer Strangulierung zu verringern, müssen die an dieser Leuchte angeschlossenen flexiblen Kabel wirksam an der Wand befestigt werden, wenn sich die Kabel in Reichweite der Arme befinden.
- Dieses Gerät kann von Kindern ab 8 Jahren und darüber sowie von Personen mit verringerten physischen, sensorischen oder mentalen Fähigkeiten oder Mangel an Erfahrung und Wissen benutzt werden, wenn sie beaufsichtigt oder bezüglich des sicheren Gebrauchs des Gerätes unterwiesen wurden und die daraus resultierenden Gefahren verstehen. Kinder dürfen nicht mit dem Gerät spielen. Reinigung und Benutzer-Wartung dürfen nicht von Kindern ohne Beaufsichtigung durchgeführt werden.

## ADVERTENCIA Riesgo de incendio y descarga eléctrica

ES



### USO SOLO EN INTERIORES

- **Este producto contiene una fuente de luz de clase de eficiencia energética <F>.**
- **El aparato solo debe alimentarse con una tensión de seguridad extra baja, conforme a la indicación marcada en el mismo.**
- Para reducir el riesgo de estrangulamiento, el cableado flexible conectado a esta luminaria debe fijarse eficazmente a la pared si el cableado está al alcance de la mano.
- Este aparato puede ser utilizado por niños a partir de 8 años y por personas con capacidades físicas, sensoriales o mentales reducidas o con falta de experiencia y conocimientos, siempre que hayan recibido supervisión o instrucciones sobre el uso seguro del aparato y comprendan los riesgos que conlleva. Los niños no deben jugar con el aparato. La limpieza y el mantenimiento por parte del usuario no deben ser realizados por niños sin supervisión.

## ADVERTÊNCIA Risco de incêndio e choque elétrico

PT



### USO APENAS EM INTERIORES.

- **Este produto contém uma fonte luminosa de classe de eficiência energética <F>.**
- **O aparelho só deve ser alimentado com tensão de segurança extra baixa, conforme indicado na marcação do próprio aparelho.**
- Para reduzir o risco de estrangulamento, a cablagem flexível ligada a esta luminária deve ser fixada de forma eficaz à parede, se a cablagem estiver ao alcance da mão.
- Este aparelho pode ser utilizado por crianças com idade igual ou superior a 8 anos e por pessoas com capacidades físicas, sensoriais ou mentais reduzidas ou com falta de experiência e conhecimento, desde que tenham recebido supervisão ou instruções sobre a utilização segura do aparelho e compreendam os riscos envolvidos. As crianças não devem brincar com o aparelho. A limpeza e a manutenção pelo utilizador não devem ser feitas por crianças sem supervisão.

## AVVERTENZE Rischio di incendio e scossa elettrica

IT



### SOLO PER USO INTERNO

- **Questo prodotto contiene una sorgente luminosa di classe di efficienza energetica <F>.**
- **L'apparecchio deve essere alimentato soltanto con tensione di sicurezza extra bassa, conforme alla marcatura riportata sull'apparecchio stesso.**
- Per ridurre il rischio di strangolamento, il cavo flessibile collegato a questo apparecchio deve essere fissato saldamente alla parete se si trova a portata di mano.
- Questo apparecchio può essere utilizzato da bambini di età superiore agli 8 anni e da persone con capacità fisiche, sensoriali o mentali ridotte o con mancanza di esperienza e conoscenza, purché siano stati istruiti o sorvegliati sull'uso sicuro dell'apparecchio e comprendano i pericoli che esso comporta. I bambini non devono giocare con l'apparecchio. La pulizia e la manutenzione da parte dell'utente non devono essere effettuate da bambini senza supervisione.



• **DOAR PENTRU UTILIZARE ÎN INTERIOR**

- Acest produs conține o sursă de lumină din clasa de eficiență energetică <F>.
  - Aparatul trebuie alimentat exclusiv cu tensiune de siguranță foarte joasă, conform marcajului de pe aparat.
  - Pentru a reduce riscul de strangulare, cablul flexibil conectat la acest corp de iluminat trebuie fixat corespunzător de perete, în cazul în care acesta se află la îndemâna mâinii.
  - Acest aparat poate fi utilizat de copii cu vârsta de cel puțin 8 ani și de persoane cu capacități fizice, senzoriale sau mentale reduse sau cu lipsă de experiență și cunoștințe, cu condiția să fi primit supraveghere sau instrucțiuni privind utilizarea aparatului în condiții de siguranță și să înțeleagă pericolele implicate. Copiii nu trebuie să se joace cu aparatul.
- Curățarea și întreținerea de către utilizator nu trebuie efectuate de copii fără supraveghere.

If you have any questions, please contact our customer care center, Our contact details are below:

**US**

 001-877-644-9366

 customerservice@aosom.com

Imported by Aosom LLC  
7777 Center Ave. Suite 430  
Huntington Beach, CA 92647-9998 USA  
MADE IN CHINA

If you have any questions, please contact our customer care center, Our contact details are below:

**CA**

 416-792-6088

 customerservice@aosom.ca

Imported by Aosom Canada Inc.  
7270 Woodbine Avenue, Unit 307, Markham,  
Ontario Canada L3R 4B9  
MADE IN CHINA

Si vous avez la moindre question, veuillez contacter notre centre d'assistance à la clientèle, Nos coordonnées sont les suivantes:

 416-792-6088

 customerservice@aosom.ca

Importé par Aosom Canada Inc.  
7270 Woodbine Avenue, unité 307,  
Markham, Ontario Canada L3R 4B9  
FABRIQUÉ EN CHINE

If you have any questions, please contact our customer care center, Our contact details are below:

**UK**

 0044-800-240-4004

 enquiries@mhstar.co.uk

IMPORTER ADDRESS:  
MH STAR UK Ltd  
1 Northampton Cross Logistics Park  
Northampton Cross Road  
Northampton  
NN4 9FH  
MADE IN CHINA

Si vous avez la moindre question, veuillez contacter notre centre d'assistance à la clientèle, Nos coordonnées sont les suivantes:

 0033-1-84166106

 aosom@mhfrance.fr

Importé par/Fabricant/REP:  
MH FRANCE  
2 Rue Maurice Hartmann  
92130 Issy Les Moulineaux  
France  
FABRIQUÉ EN CHINE



**FR**

Cet appareil, ses accessoires, cordons et batteries se recyclent

REPRISE À LA LIVRAISON



À DÉPOSER EN MAGASIN



À DÉPOSER EN DÉCHÈTERIE



Points de collecte sur [www.quefairedemesdechets.fr](http://www.quefairedemesdechets.fr)  
Privilégiez la réparation ou le don de votre appareil !

Si tiene alguna pregunta, comuníquese con nuestro Centro de Atención al Cliente, Nuestros datos de contacto son los siguientes:

**ES**

 0034-931294512

 atencioncliente@aosom.es

IMPORTADOR/Fabricante/REP:  
SPANISH AOSOM, S.L.  
C/ROC GROS, N°15.08550, ELS HOSTALET DE BALENYÀ, SPAIN.  
B66295775  
HECHO EN CHINA

Se tiver alguma dúvida, por favor contacte o nosso Centro de Atendimento ao Cliente, Os nossos dados de contacto são os seguintes:

 0034-931294512

 info@aosom.pt.

IMPORTADOR/Fabricante/REP:  
SPANISH AOSOM, S.L.  
C.ROC GROS N.15, 08550. ELS HOSTALET DE BALENYÀ  
FEITO NA CHINA

In caso di dubbio, si prega di contattare il nostro centro assistenza clienti, I nostri dettagli di contatto sono di seguito:

**IT**

 0039-0249471447

 clienti@aosom.it

IMPORTATO DA/Produttore/REP:  
AOSOM Italy srl  
Centro Direzionale Milanofiori  
Strada 1 Palazzo F1  
20057 Assago (MI)  
P.I.: 08567220960  
FATTO IN CINA

Wenn Sie Fragen haben, wenden Sie sich bitte an unser Kundendienstzentrum, Unsere Kontaktdaten stehen unten:

**DE**

 0049-0(40)-87408465

 service@aosom.de

ADRESSE DES IMPORTEURE/Hersteller/REP:  
MH Handel GmbH  
Wendenstraße 309  
D-20537 Hamburg  
Germany  
IN CHINA HERGESTELLT