

AIYAPLAY

IN240600359V02_UK_FR_DE_ES_PT_IT

349-005V00_349-005V01

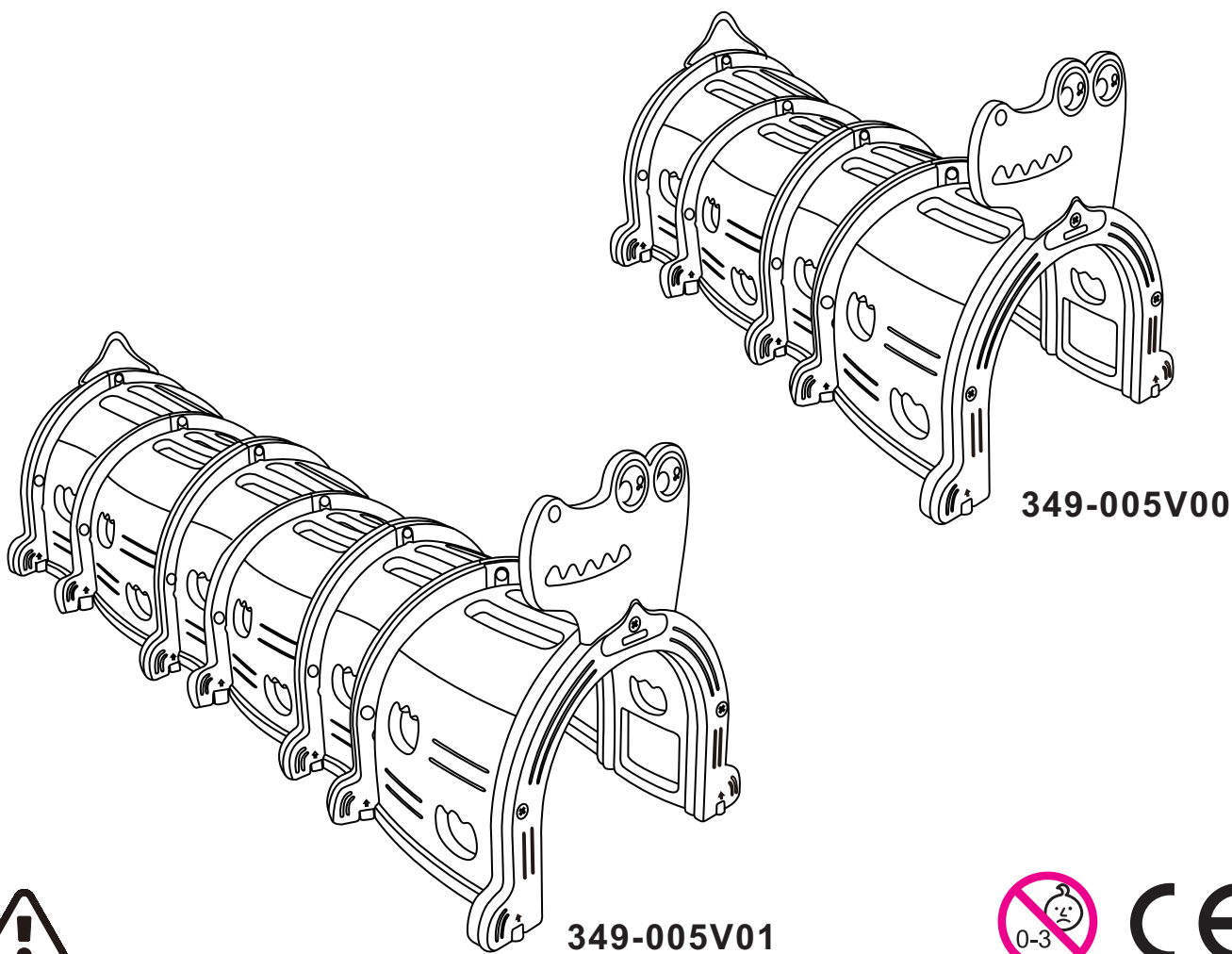

EN_WARNING: Suitable for children of 36 months+;
FR_ATTENTION: Convient aux enfants de 36 mois+ ;
DE_ACHTUNG: Geeignet für Kinder im Alter von 36 Monate+
ES_ADVERTENCIA: Adecuado para los niños de 36 meses+ ;
PT_ATENÇÃO: Adequado para crianças de 36 meses+ ;
IT_AVVERTENZA: Adatto a bambini di 36 mesi+.

EN_IMPORTANT, RETAIN FOR FUTURE REFERENCE: READ CAREFULLY.

FR_IMPORTANT : A LIRE ATTENTIVEMEN ET A CONSERVER POUR VOUS Y REFERER ULTERIEUREMENT.

ES_IMPORTANTE, LEA Y GUARDE PARA FUTURAS REFERENCIAS.

PT_IMPORTANTE, RETER PARA REFERÊNCIA FUTURA: LEIA ATENTAMENTE.

DE_WICHTIG! SORGFÄLTIG LESEN UND FÜR SPÄTER NACHSCHLAGEN AUFBEWAHREN.

IT_IMPORTANTE! CONSERVARE IL PRESENTE MANUALE PER FUTURO RIFERIMENTO E LEGGERLO ATTENTAMENTE.

EN

WARNING:

1. CHOKING HAZARD—Small parts. Not suitable for children under 3 years.
2. Only allowed for adults to install, keep children away.
3. To be used under the direct supervision of an adult.
4. Keep away from fire! Keep away from water!

MAINTENANCE & CARE

- A. Keep all instructions and parts relating to this product for future reference.
- B. If any problem occurred, please sent it to qualified maintainer.
- C. Clean your toy with a clean damp cloth.

DE

ACHTUNG:

1. ERSTICKUNGSGEFAHR — Kleine Teile. Nicht für Kinder unter 3 Jahren geeignet.
2. Die Montage darf nur von Erwachsenen vorgenommen werden, halten Sie Kinder fern.
3. Es ist unter der direkten Aufsicht eines Erwachsenen zu verwenden.
4. Halten Sie es von Feuer fern! Halten Sie es von Wasser fern!

WARTUNG & PFLEGE

- A. Bewahren Sie alle Anweisungen und Teile, die sich auf dieses Produkt beziehen, zur späteren Verwendung auf.
- B. Bei Auftreten eines Problems, suchen Sie bitte eine qualifizierten Werkstatt auf.
- C. Reinigen Sie das Spielzeug mit einem sauberen, feuchten Tuch.

FR

ATTENTION :

1. DANGER D'ÉTOUFFEMENT—Petits éléments. Ne convient pas aux enfants de moins de 3 ans.
2. Installation par des adultes uniquement, tenir les enfants à l'écart.
3. À utiliser sous la surveillance directe d'un adulte.
4. Loin du feu ! Loin de l'eau !

ENTRETIEN ET MAINTENANCE

- A. Conservez toutes les instructions et les pièces relatives à ce produit pour pouvoir vous y référer ultérieurement.
- B. Si un problème survient, veuillez l'envoyer à un technicien qualifié.
- C. Nettoyez votre jouet avec un chiffon propre et humide.



Adresses sur quefairedemesdechets.fr

ADVERTENCIAS:

1. PELIGRO DE ATRAGANTAMIENTO—Partes pequeñas. No apto para menores de 3 años.
2. La instalación sólo se puede realizar por los adultos, mantenga a los niños alejados al instalar el producto.
3. El producto debe ser utilizado bajo la supervisión directa de un adulto.
4. ¡Mantenga el producto alejado del fuego y del agua!

MANTENIMIENTO Y CUIDADO

- A. Guarde todas las instrucciones y piezas relativas juntas con este producto para las referencias futuras.
- B. Si tiene algún problema, envíe el producto a un profesional de mantenimiento cualificado.
- C. Limpie el juguete con un paño húmedo y limpio.

AVISOS

1. RISCO DE ASFIXIA—Pequenas partes. Não é adequado para crianças com menos de 3 anos.
2. A instalação só é permitida a adultos, manter as crianças afastadas.
3. Para ser usado sob a supervisão direta de um adulto.
4. Manter afastado do fogo! Manter afastado da água!

MANUTENÇÃO E CUIDADOS

- A. Guarde todas as instruções e peças relacionadas com este produto para referência futura.
- B. Se ocorrer algum problema, envie-o ao responsável pela manutenção qualificado.
- C. Limpe o seu brinquedo com um pano limpo e húmido.

AVVERTENZE:

1. RISCHIO DI SOFFOCAMENTO— Piccole parti. Non adatto a bambini di età inferiore a 3 anni.
2. Consentito solo agli adulti di installare, tenere lontani i bambini.
3. Da utilizzare sotto la diretta supervisione di un adulto.
4. Tenere lontano dal fuoco! Tenere lontano dall'acqua!

MANUTENZIONE & CURA

- A. Conservare tutte le istruzioni e le parti relative a questo prodotto per riferimenti futuri.
- B. Se si verifica un problema, chiedere assistenza a un manutentore qualificato.
- C. Pulire il vostro giocattolo con un panno umido pulito.

349-005V00

A x 2

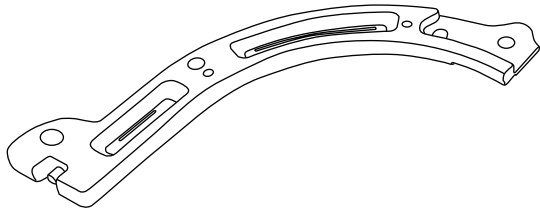

A1

B x 2

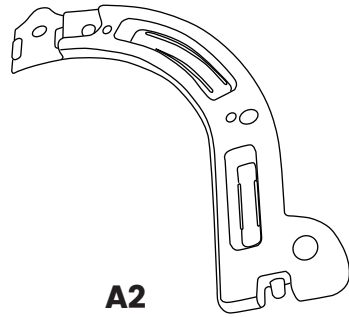

A2

C x 8

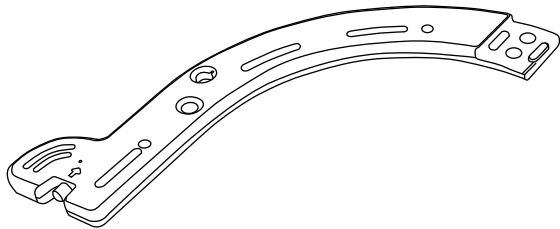

B1

D x 8

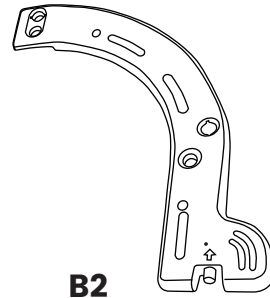

B2

E x 1

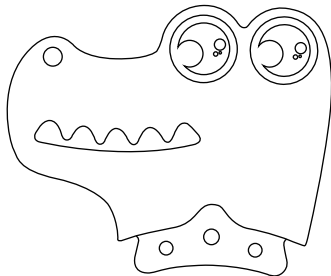

F x 1

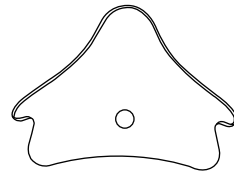

G x 4

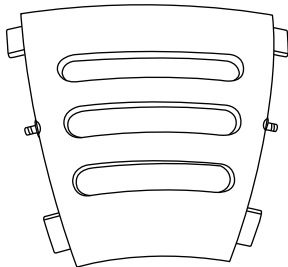

H x 4

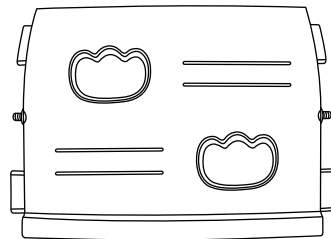

I x 4

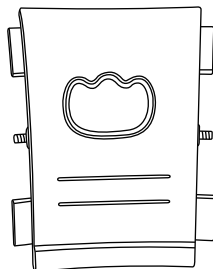

J X10+1(spare)

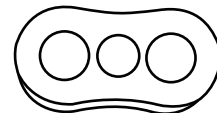

K X39+1(spare)

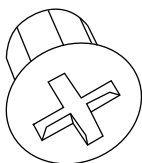

L X15+1(spare)

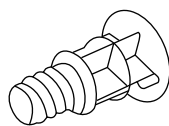

M X1



N X1



349-005V01

BOX-1/2

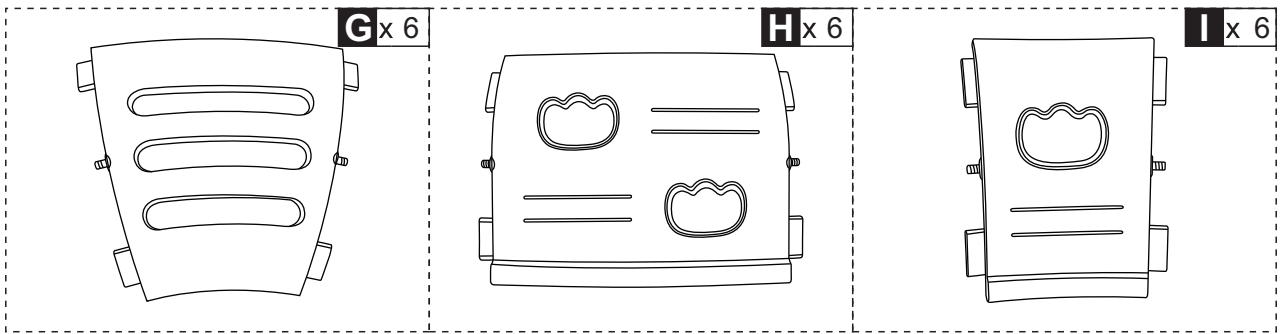

BOX-2/2

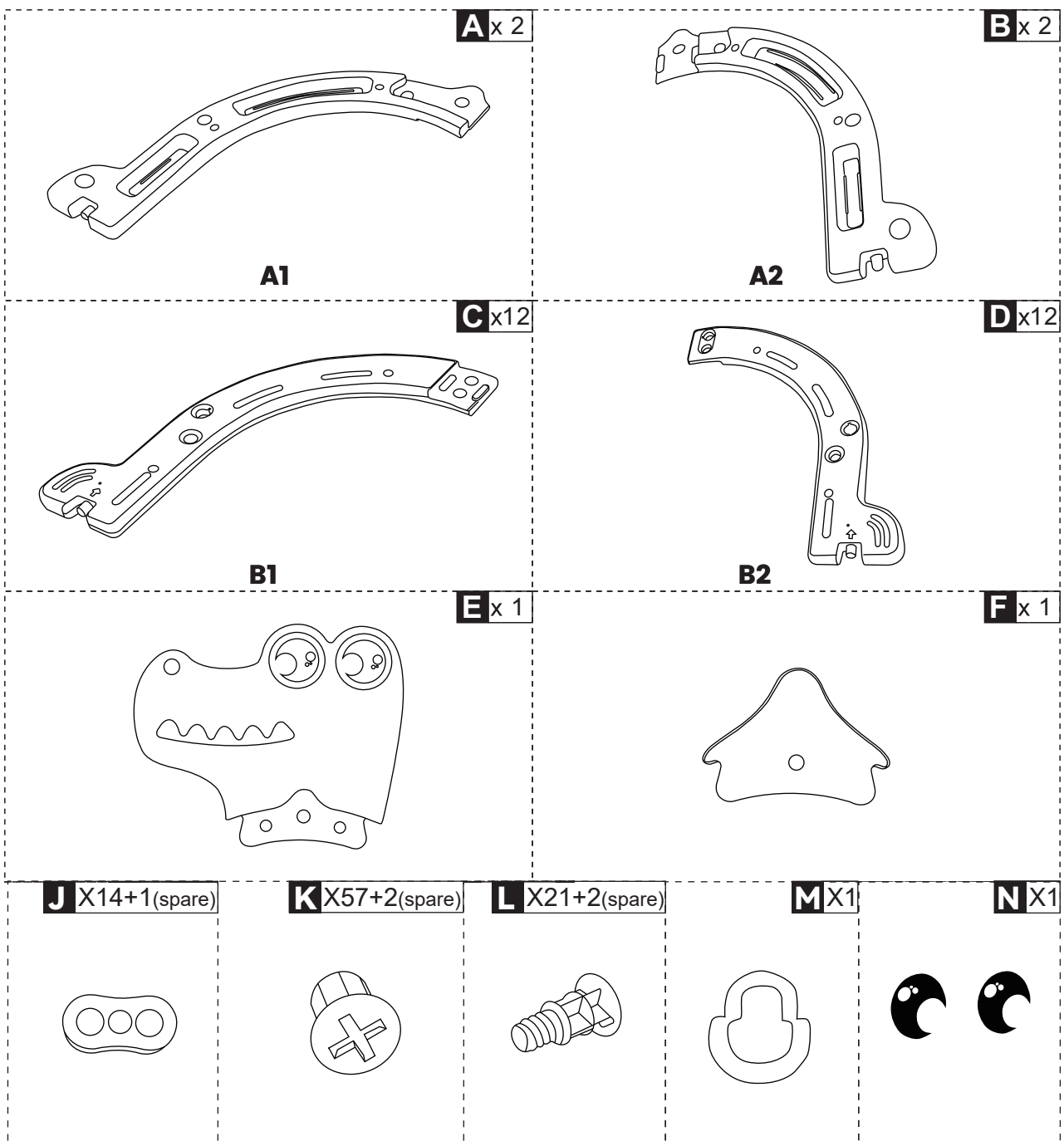

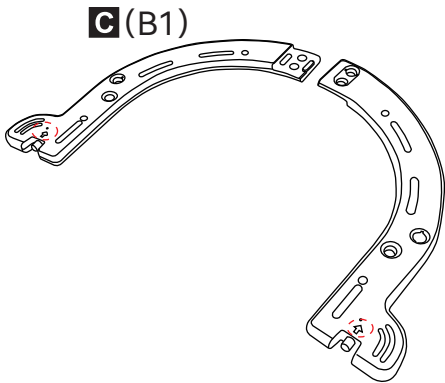

D(B2)

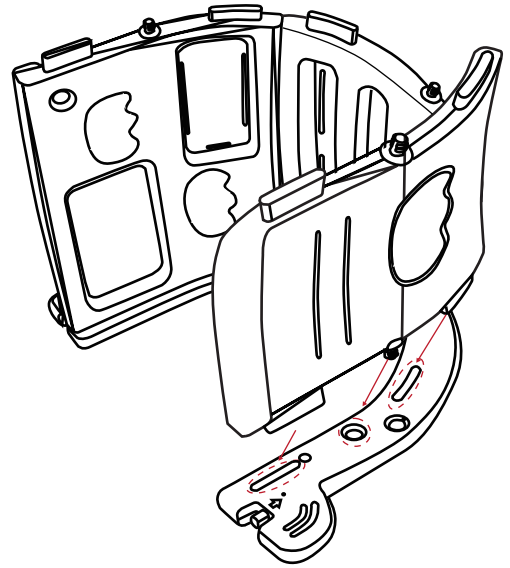
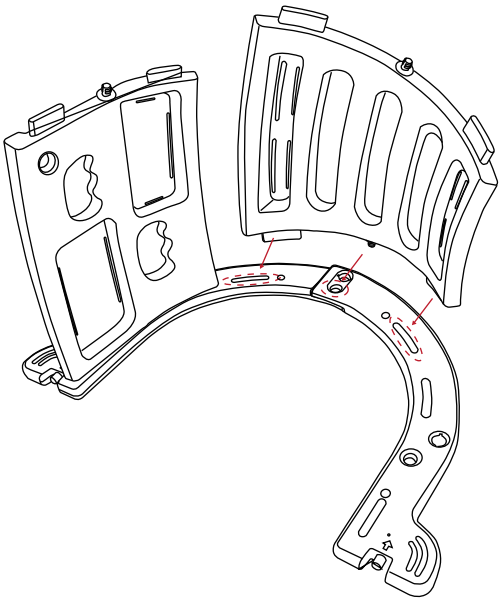
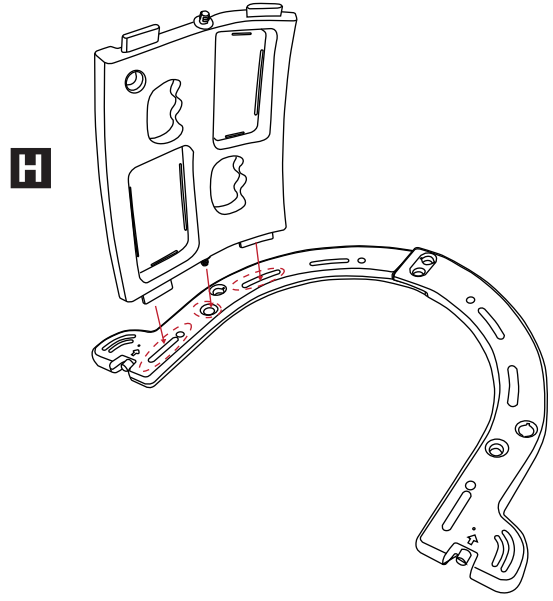

C(B1)

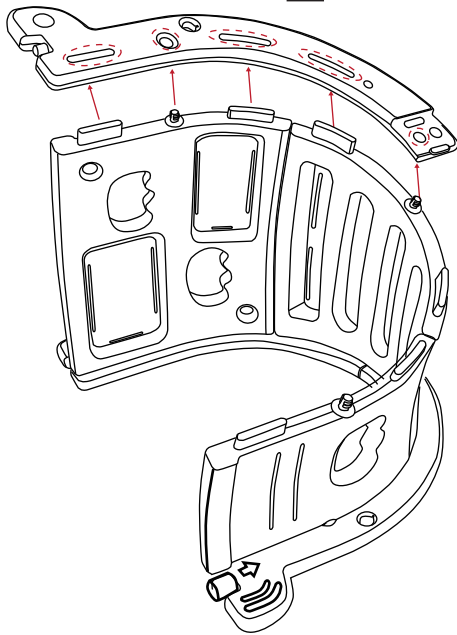

D(B2)

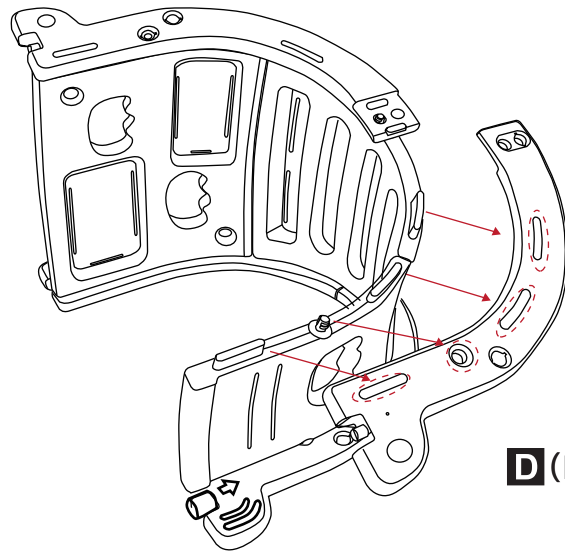

K X6



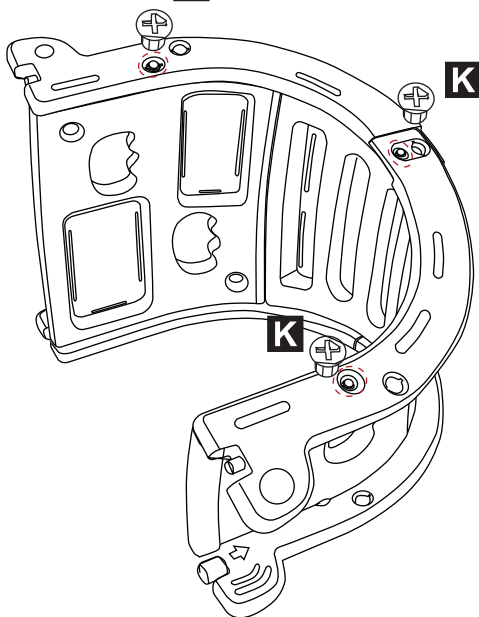

K



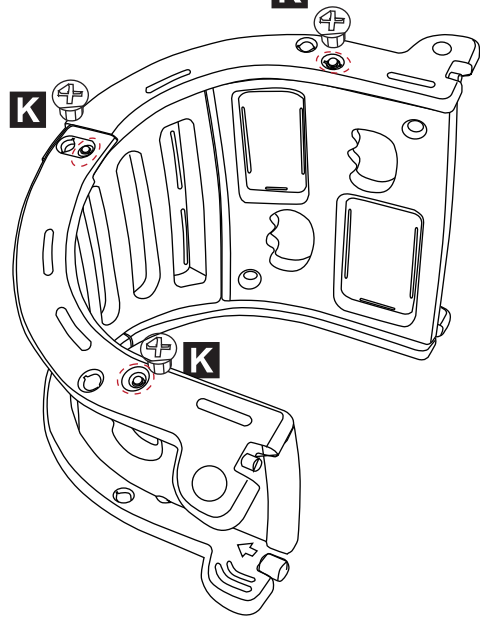

K

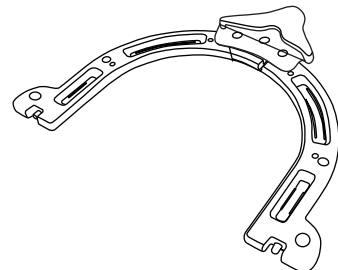
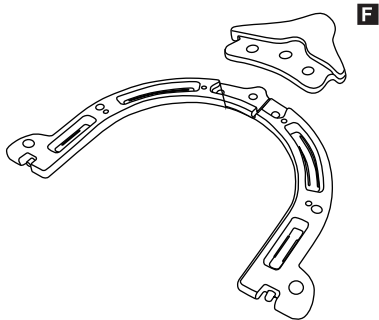
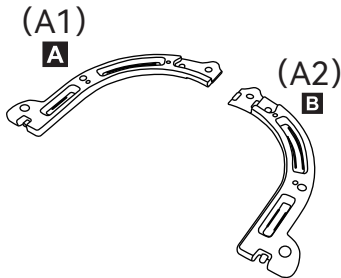
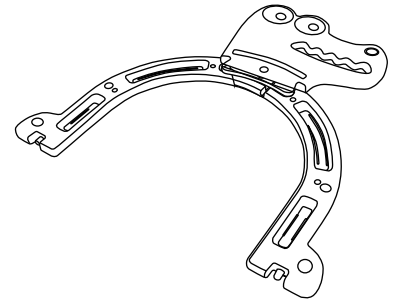
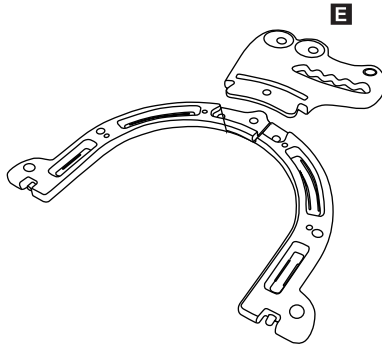
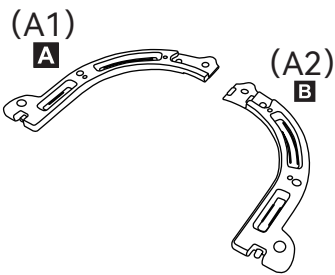
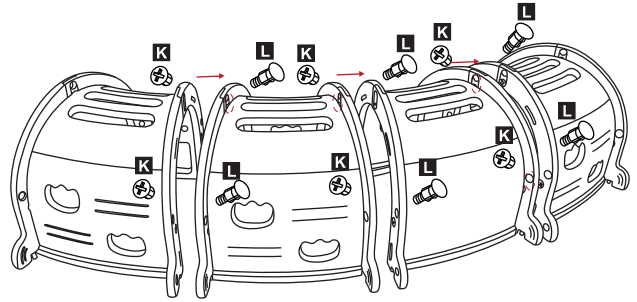
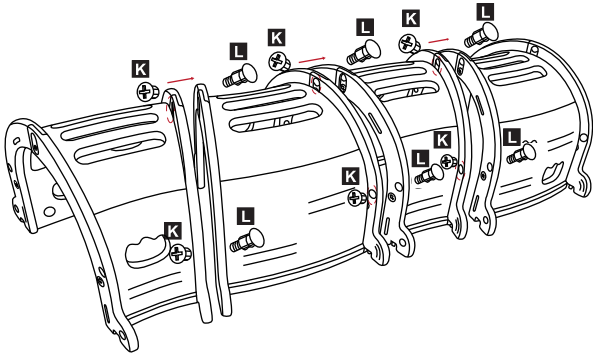
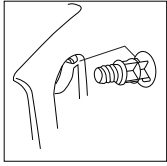

K X9	L X9
	



K X6	L X6
	

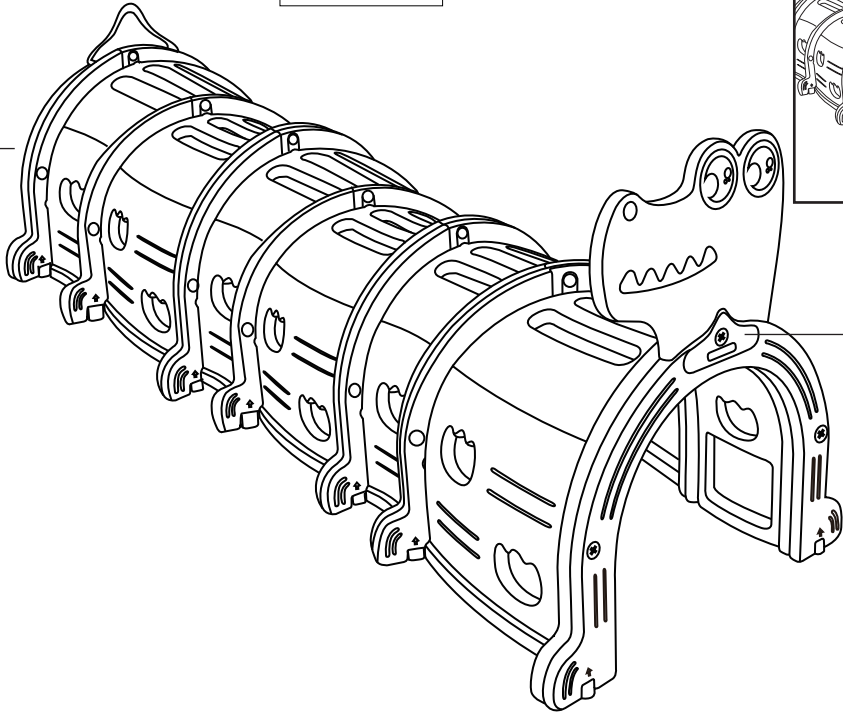
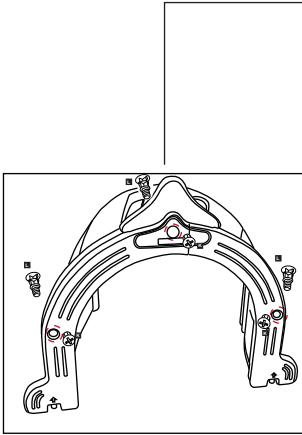
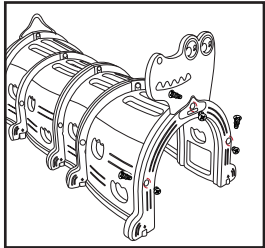
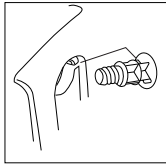

J X14

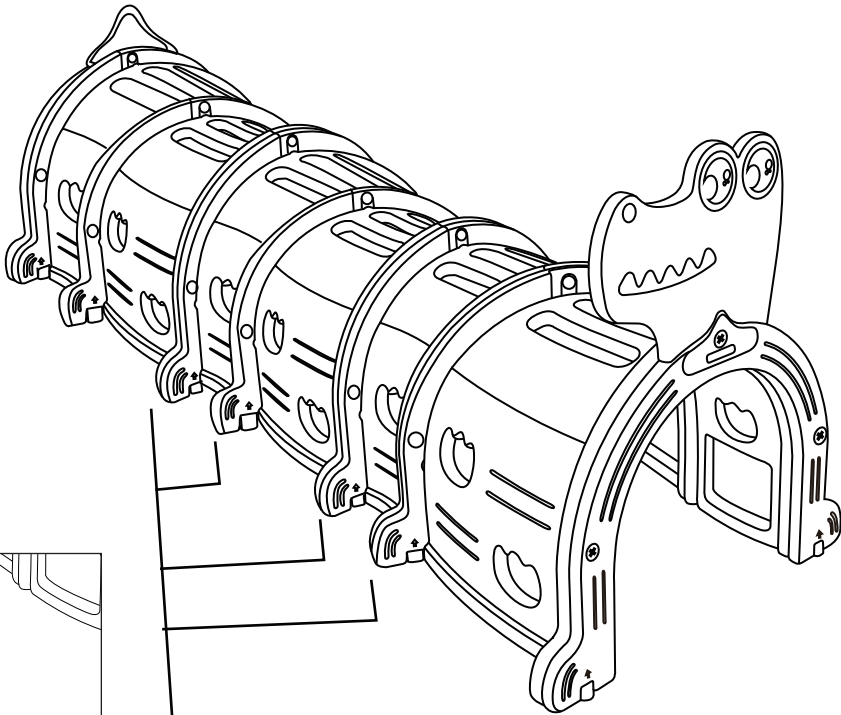
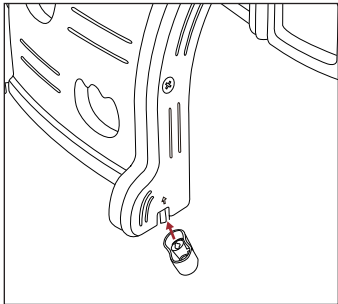

UK

If you have any questions, please contact our customer care centre.

Our contact details are below:



0044-800-240-4004



enquiries@mhstar.co.uk

IMPORTER ADDRESS:

MH STAR UK Ltd
1 Northampton Cross Logistics Park
Northampton Cross Road
Northampton
NN4 9FH
MADE IN CHINA

ES

Si tiene alguna pregunta, comuníquese con nuestro Centro de Atención al Cliente. Nuestros datos de contacto son los siguientes:



0034-931294512



atencioncliente@aosom.es

Importador/Fabricante/REP:

Spanish Aosom, S.L.
C/ Roc Gros, nº 15. 08550, Els Hostalets de Balenyà, Spain.
B66295775
atencioncliente@aosom.es
TEL: 931294512
HECHO EN CHINA

FR

Si vous avez la moindre question, veuillez contacter notre centre d'assistance à la clientèle.

Nos coordonnées sont les suivantes:



0033-1-84166106



aosom@mhfrance.fr

Importé par/Fabricant/REP:

MH France
2, rue Maurice Hartmann
92130 Issy-les-Moulineaux
France
FABRIQUÉ EN CHINE

PT

Se tiver alguma dúvida, por favor contacte o nosso Centro de Atendimento ao Cliente. Os nossos dados de contacto são os seguintes:



0034-931294512



info@aosom.pt.

IMPORTADOR:

SPANISH AOSOM, S.L
C.ROC GROS N.15, 08550. ELS HOSTALETES DE BALENYÀ
TEL: 931294512 (SEG-SEX DAS 7:30H ÀS 16:30H)
INFO@AOSOM.PT
WWW.AOSOM.PT

DE

Wenn Sie Fragen haben, wenden Sie sich bitte an unser Kundendienstzentrum.

Unsere Kontaktdaten stehen unten:



0049-0(40)-87408465



service@aosom.de

Importeur/Hersteller/REP:

MH Handel GmbH
Wendenstraße 309
D-20537 Hamburg
Germany
IN CHINA HERGESTELLT

IT

In caso di dubbio, si prega di contattare il nostro centro assistenza clienti. I nostri dettagli di contatto sono di seguito:



0039-0249471447



clienti@aosom.it

IMPORTATO DA/Produttore/REP:

AOSOM Italy srl
Centro Direzionale Milanofiori
Strada 1 Palazzo F1
20057 Assago (MI)
P.I.: 08567220960
FATTO IN CINA

