

PawHut

IN240600082V01

D06-238V10_D06-238V11_D06-238V12

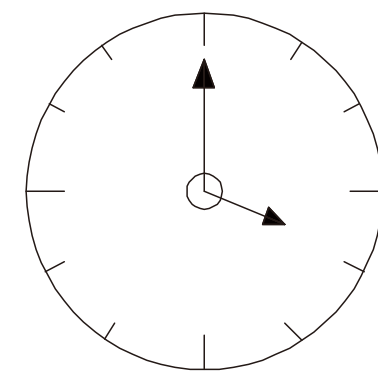

5
STEPS

0.5 HR

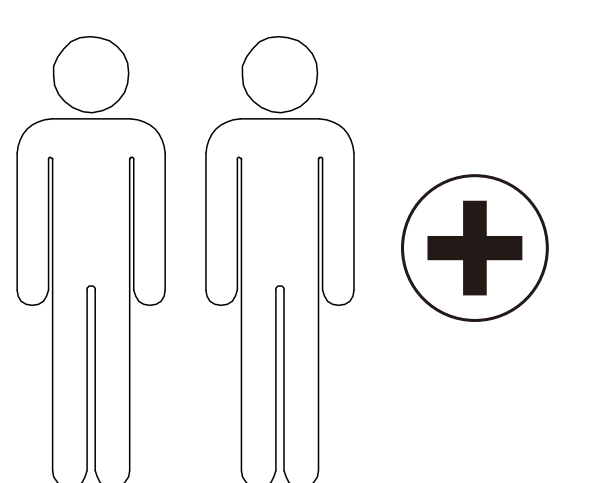

EN_ IMPORTANT, RETAIN FOR FUTURE REFERENCE: READ CAREFULLY.

FR_ IMPORTANT:A LIRE ATTENTIVEMENT ET À CONSERVER POUR CONSULTATION ULTÉRIEURE.

ES_ IMPORTANTE, LEA Y GUARDE PARA FUTURAS REFERENCIAS.

DE_ WICHTIG! SORGFÄLTIG LESEN UND FÜR SPÄTER NACHSCHLAGEN AUFBEWAHREN.

**IT_ IMPORTANTE! CONSERVARE IL PRESENTE MANUALE PER FUTURO RIFERIMENTO E
LEggerlo ATTENTAMENTE.**

**Adjustable width
different extension fits openings width:**

**Ancho ajustable
Diferentes extensiones se adaptan a los anchos de las aberturas:**

**Larghezza regolabile
Estensioni diverse si adattano alla larghezza delle aperture:**

**Largeur réglable
les différentes extensions s'adaptent à la largeur des ouvertures :**

**Einstellbare Breite
Verschiedene Verlängerung passt zu Öffnungsbreiten:**

**largura ajustável
diferentes extensões adaptam-se à largura das aberturas:**

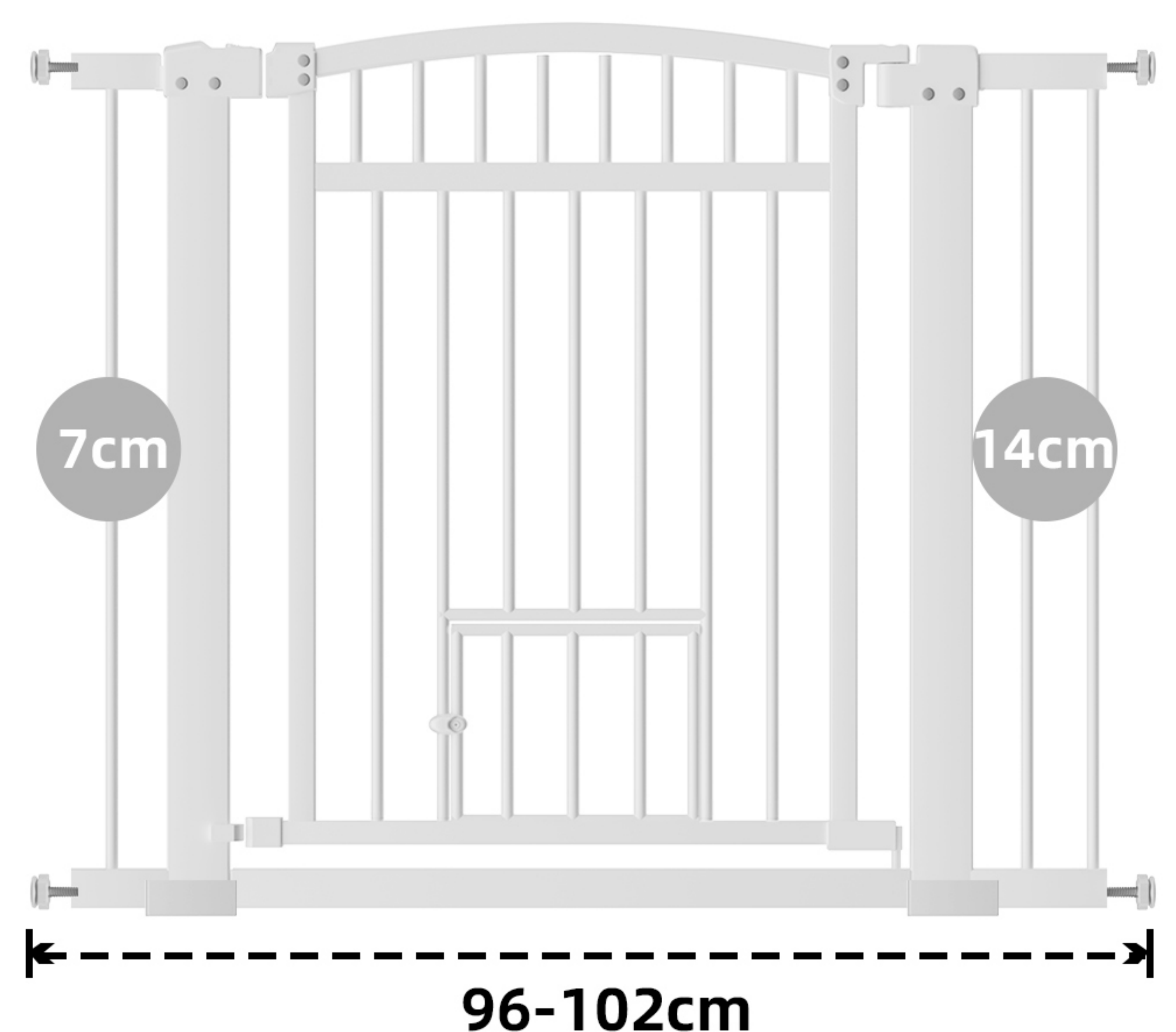
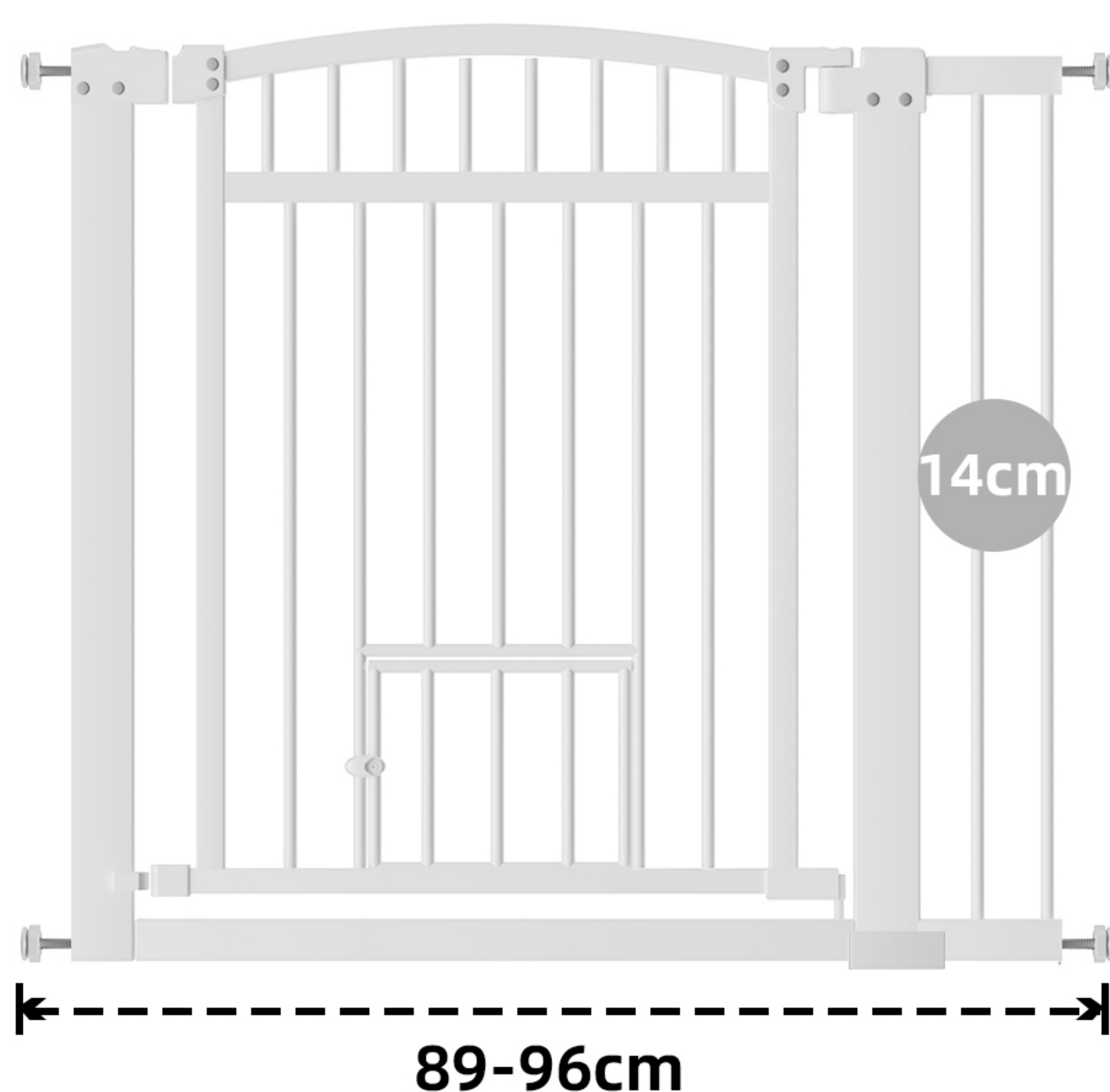
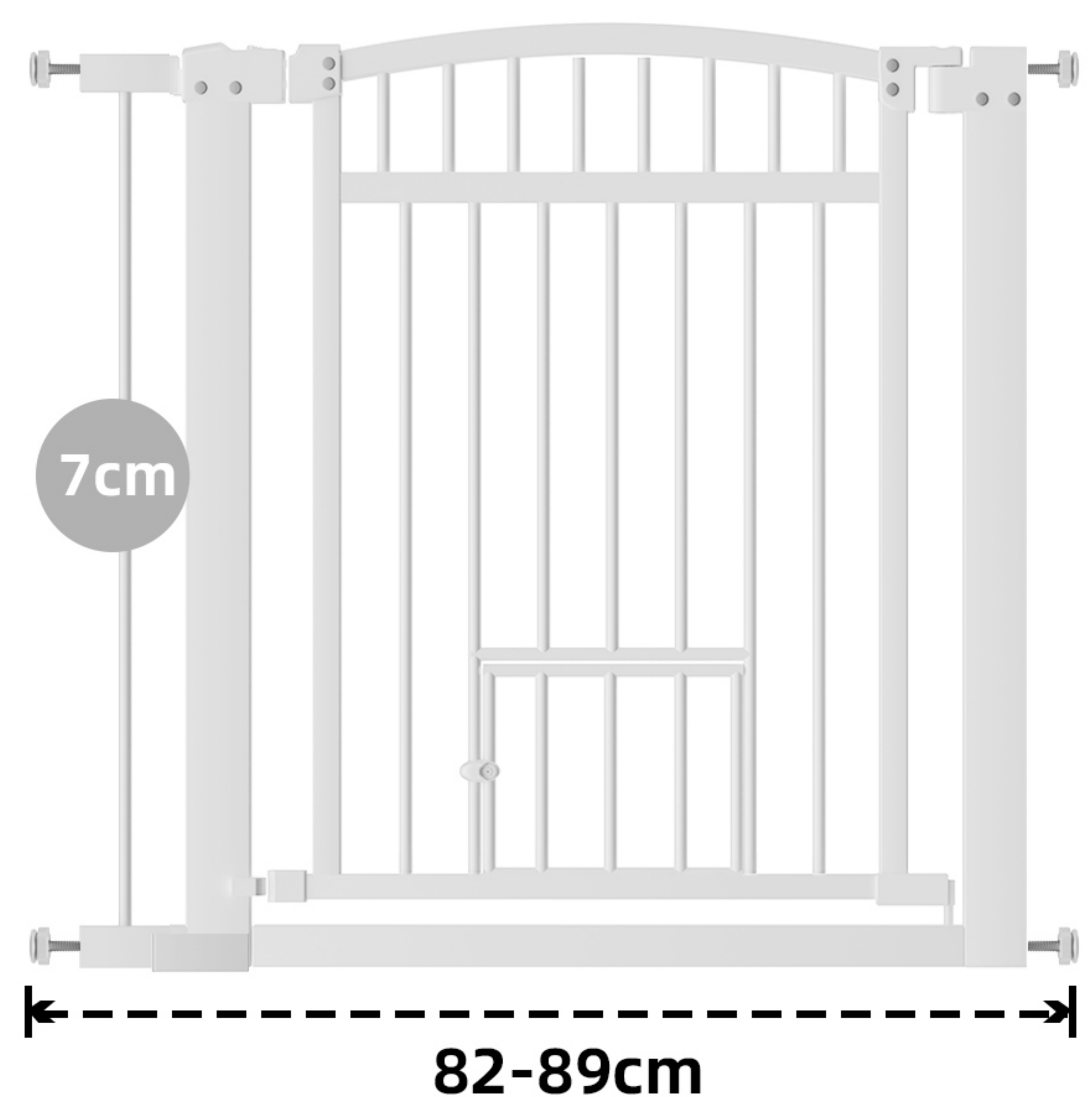
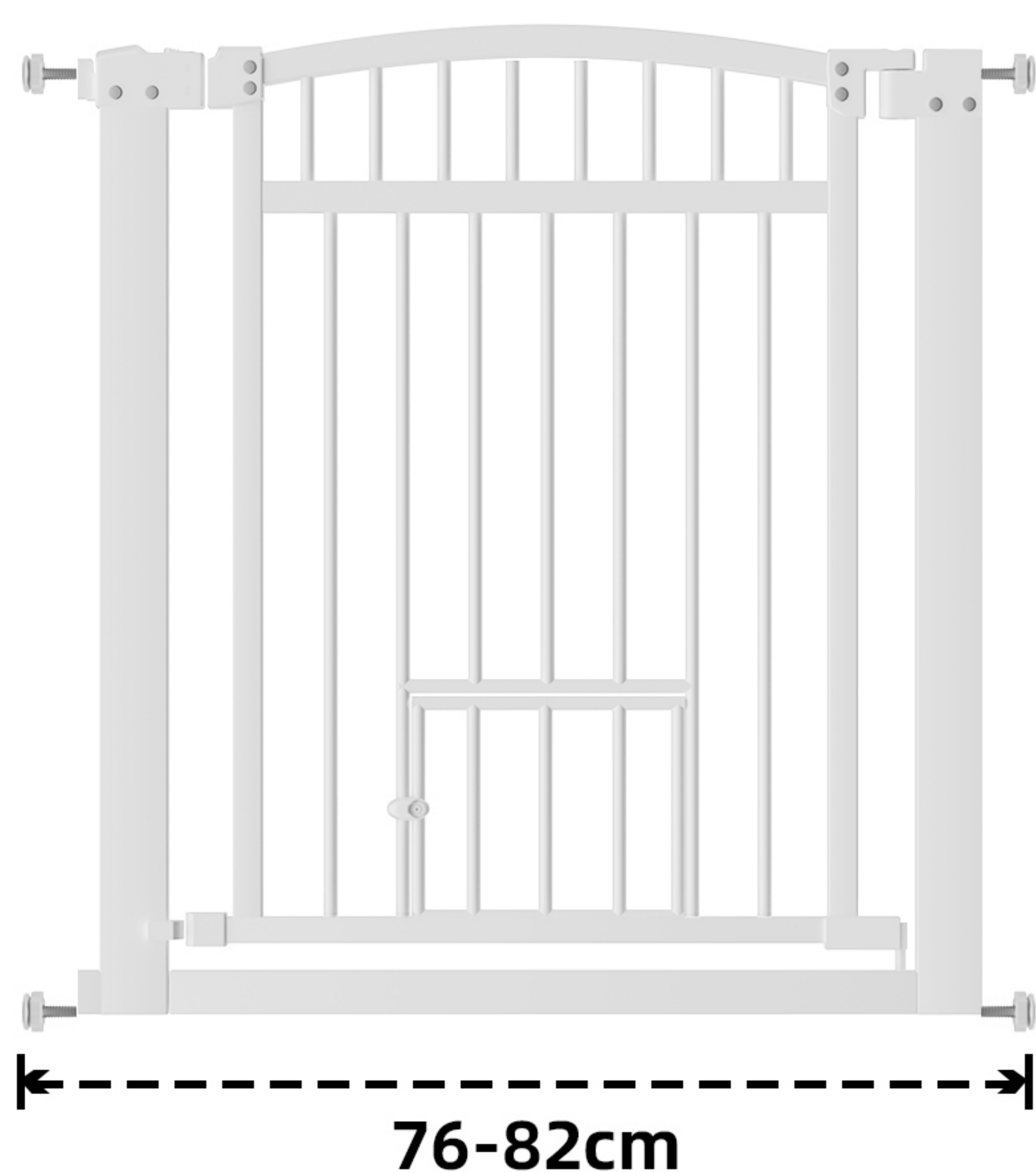



Product & Parts

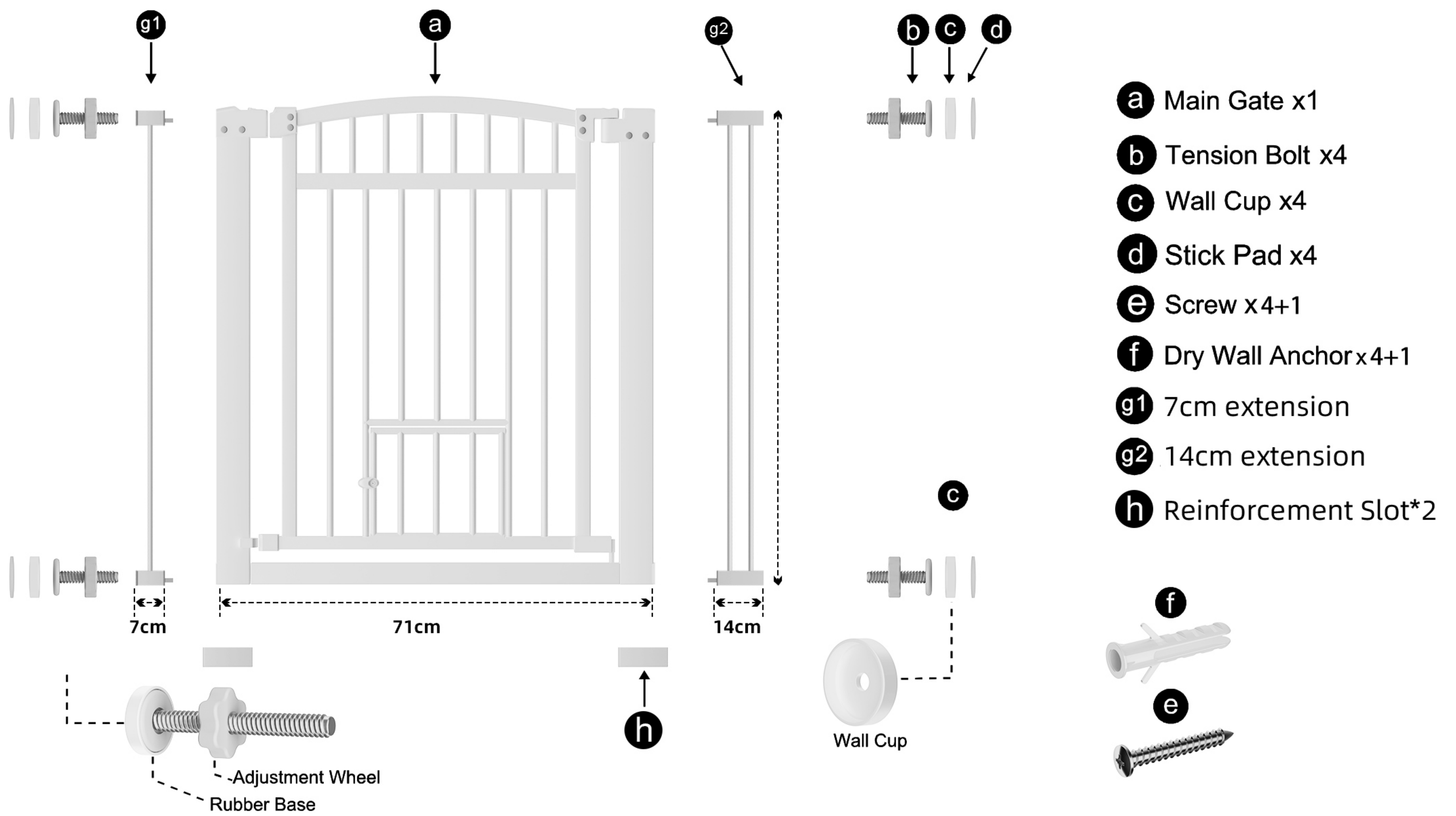

 The picture is only for reference, please make the object as the standard.

 **WARNING:** This package contains small parts and sharp points in an unassembled state. Keep out of reach of children. Adult assembly required.

WARNING:

To help your installation, **Do not cut off the belt** before installation is completed! **The door gap is NOT a defect!** It will be shortened to 0.2cm after installation.

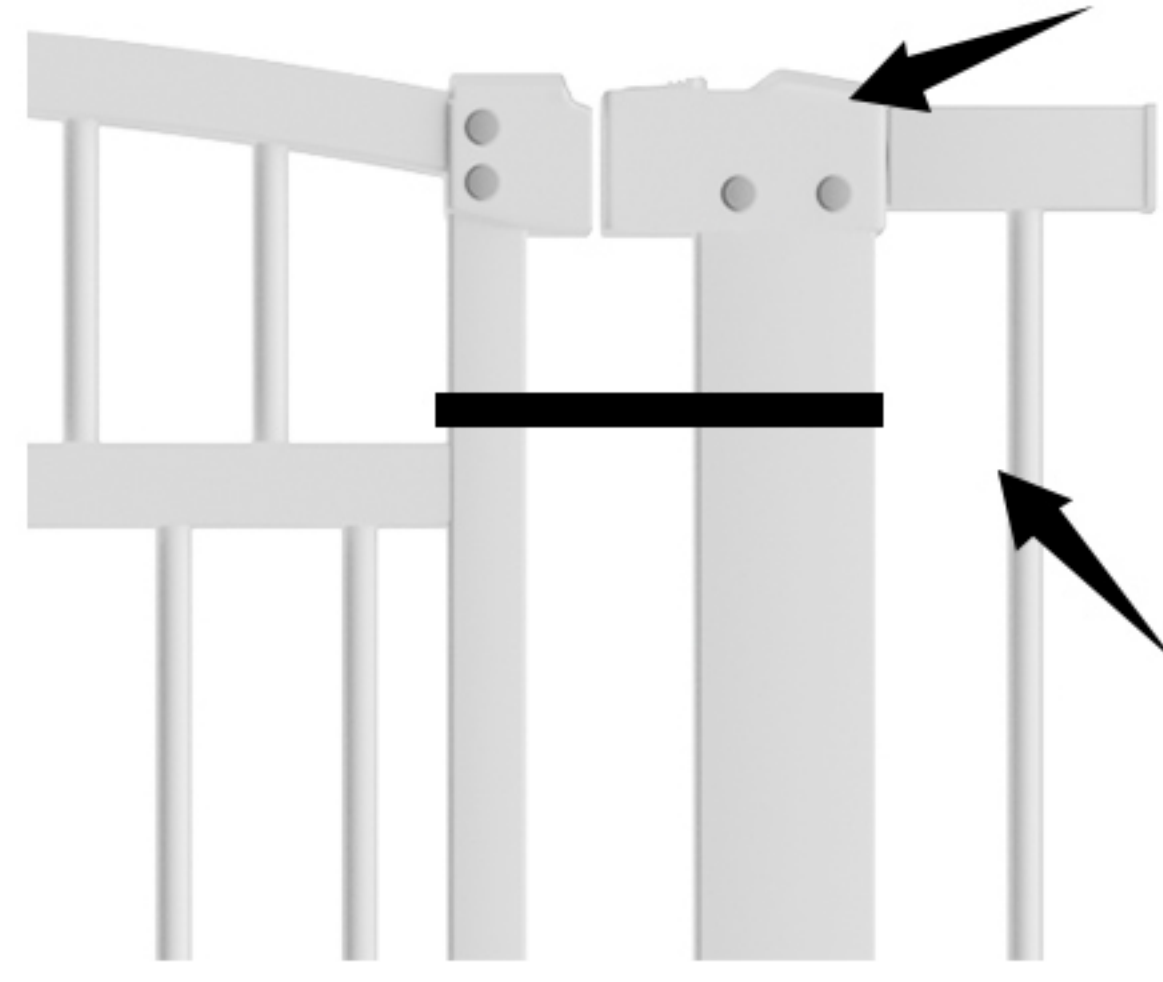

The door gap is NOT a defect! after installation, it will be shortened to 0.2cm



DO NOT CUT THE BELT before the installation is completed.



Notice: screw in Mounting Cups when using gate on stairs



Bottom of stairs

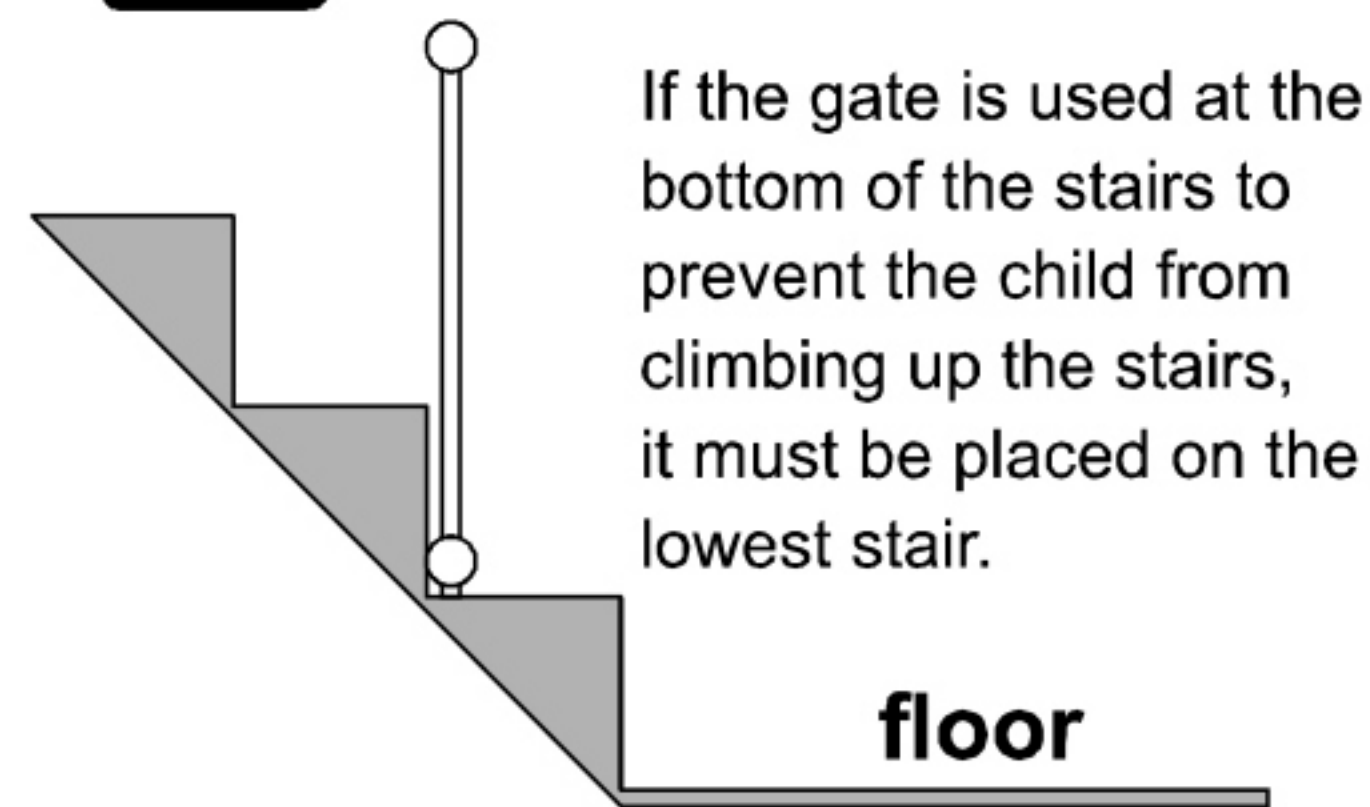

If the gate is used at the bottom of the stairs to prevent the child from climbing up the stairs, it must be placed on the lowest stair.



Top of stairs

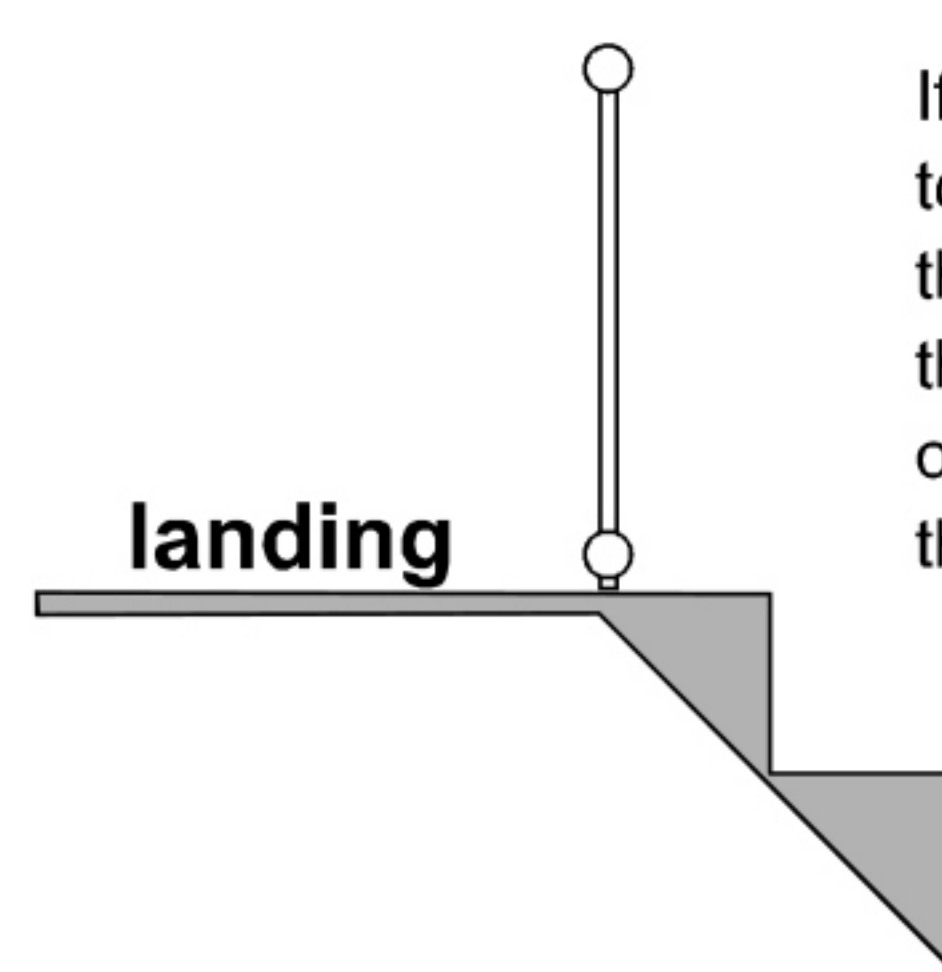

If the gate is used at the top of the stairs to prevent the child from falling down the stairs, it must be placed on any stair below the level of the top stair.

STEP1.

Pre-assemble the gate, and locate four points for hole drilling. Hold the wall cup in position and mark the center with a pencil.

PLEASE NOTE: The gate should be resting on the floor. **DO NOT** allow a gap of more than 0.5cm between the gate and the floor.

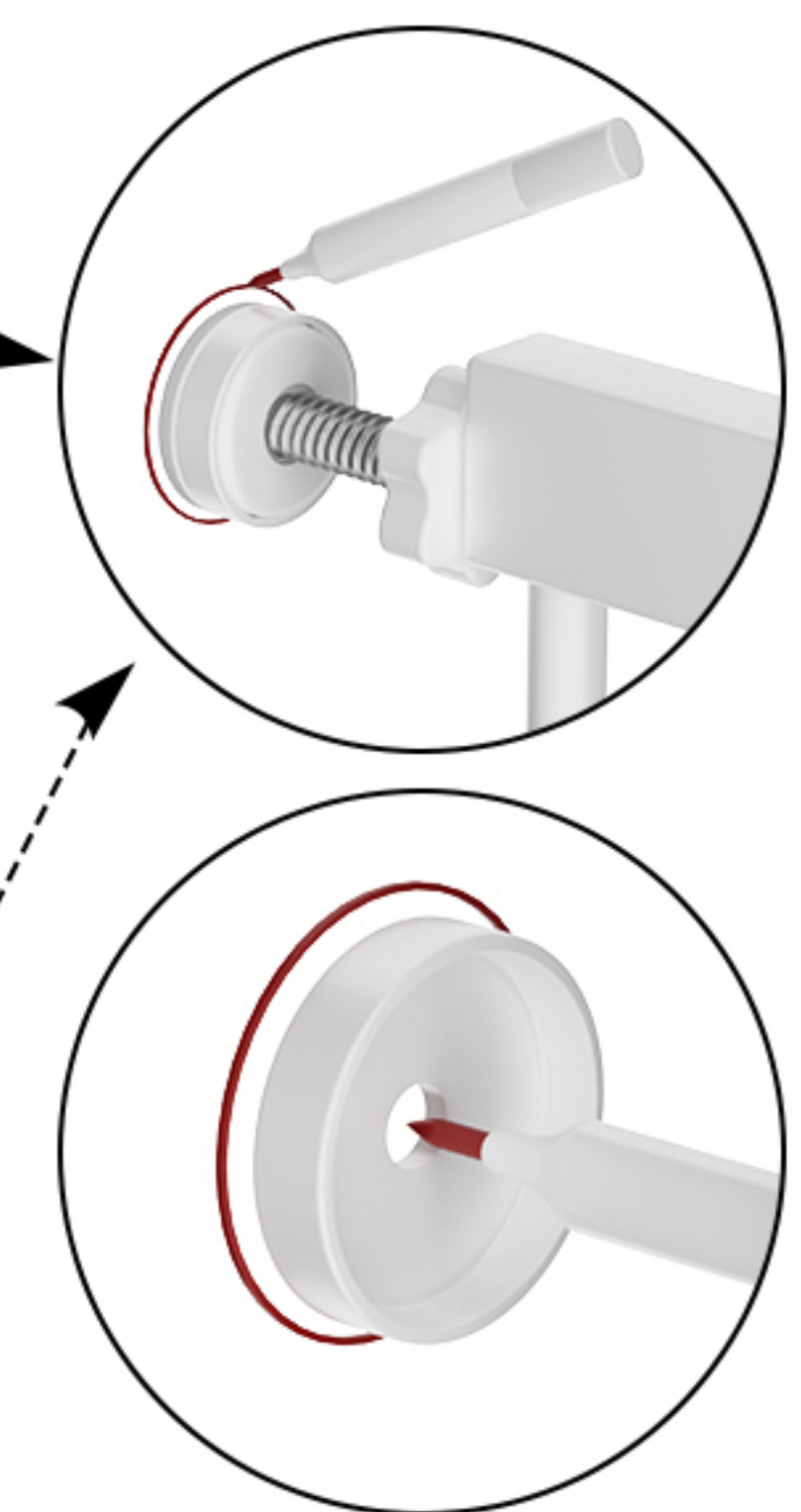
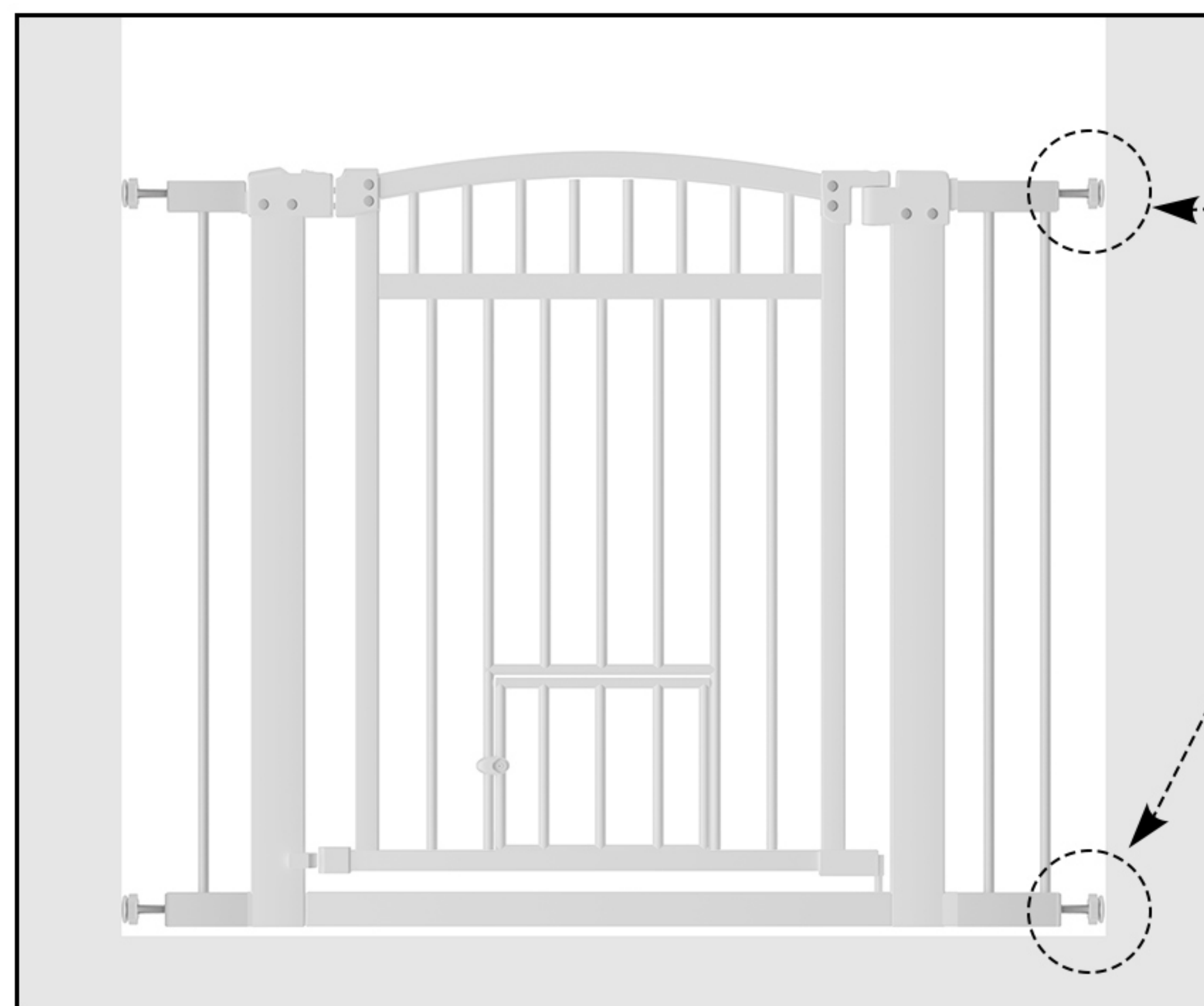
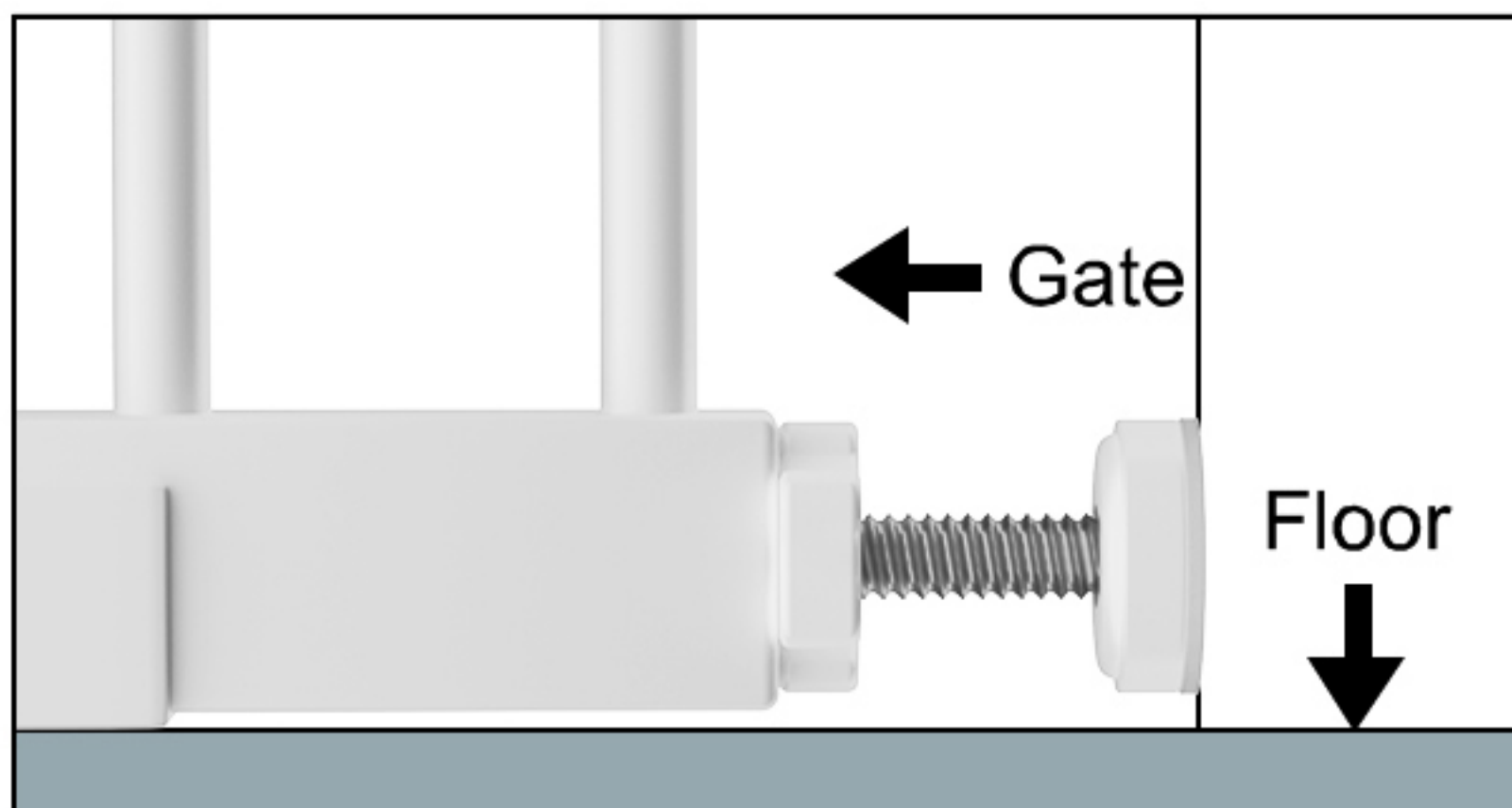

STEP2.

Stick pad when using pressure mounted installation. Remove two side of the sticky pad, stick 4 pads to 4 wall cups. Then wall cups cover the bolts.

TIP: If you do not have to worry about damaging the walls, skip this step.

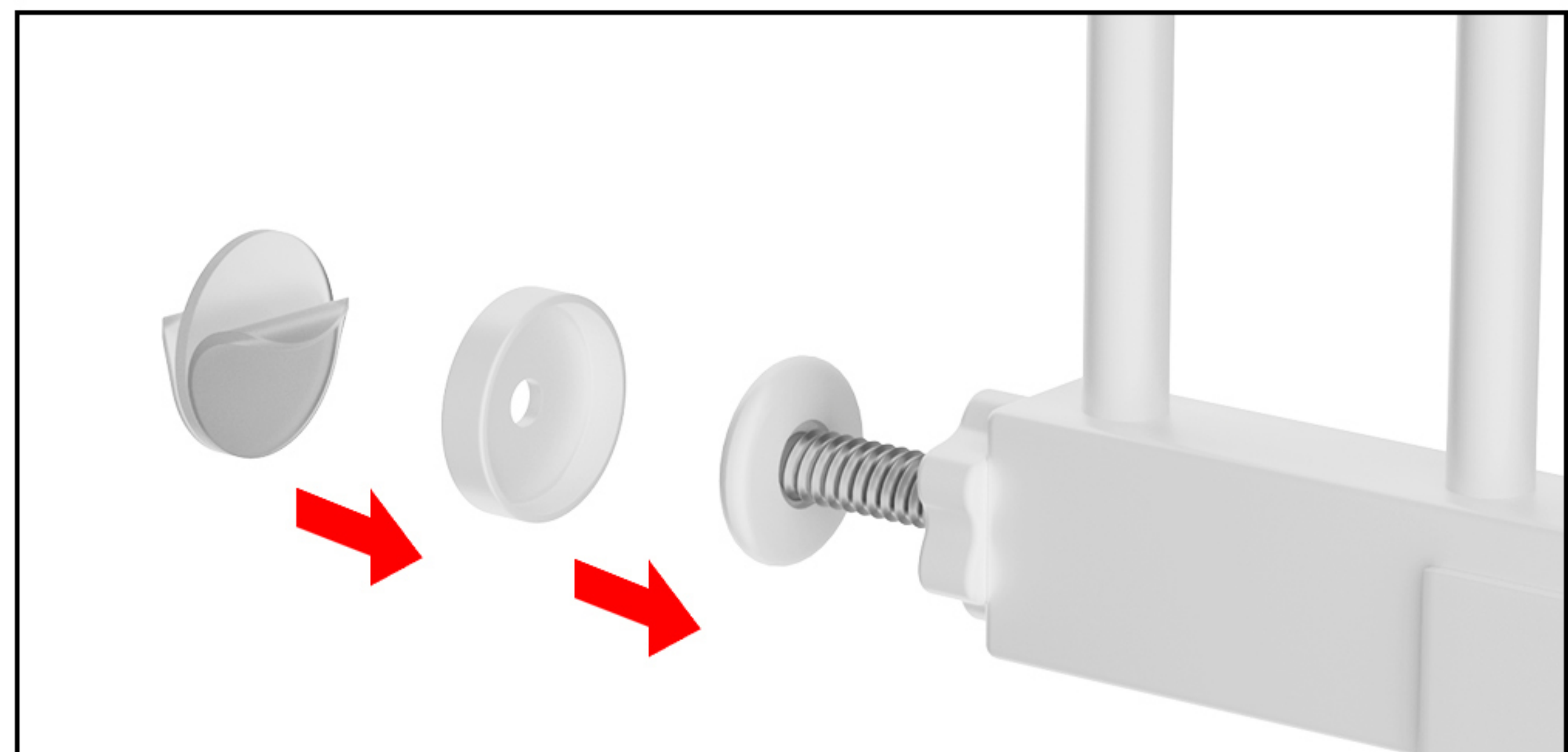

STEP3.

Drill hole for the 4 marked positions, then put dry wall anchor(g) and use screw(f) and the wall cup (d)

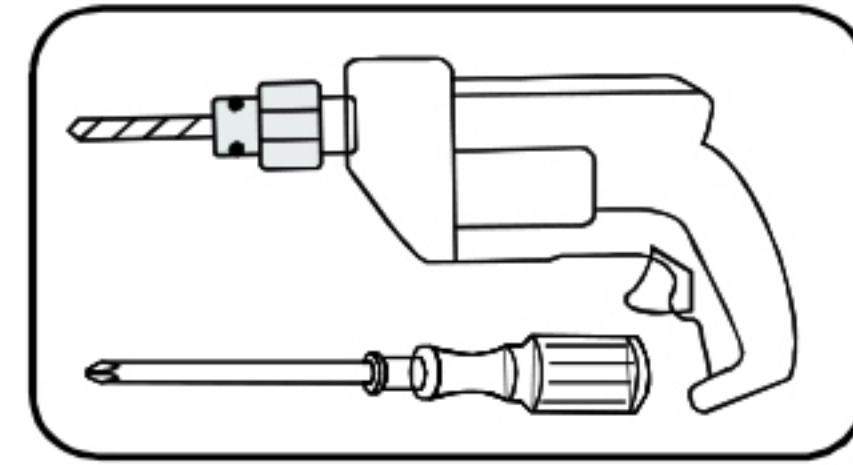
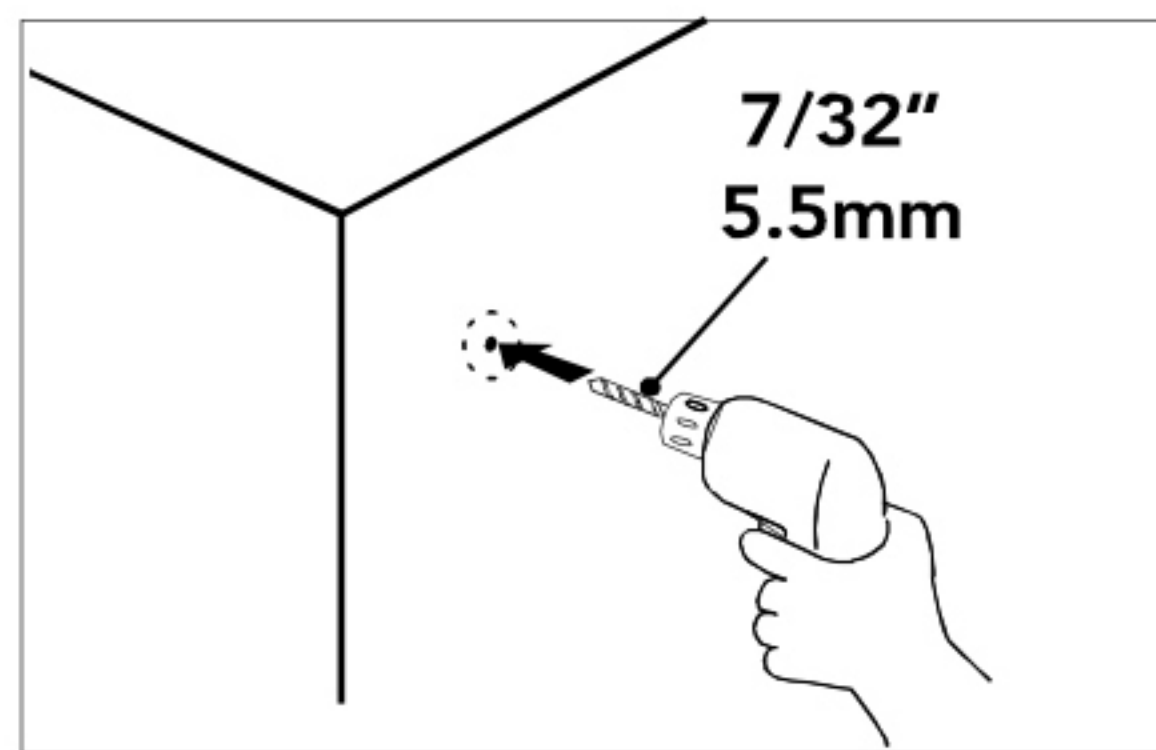

The product does not contain the installation tool

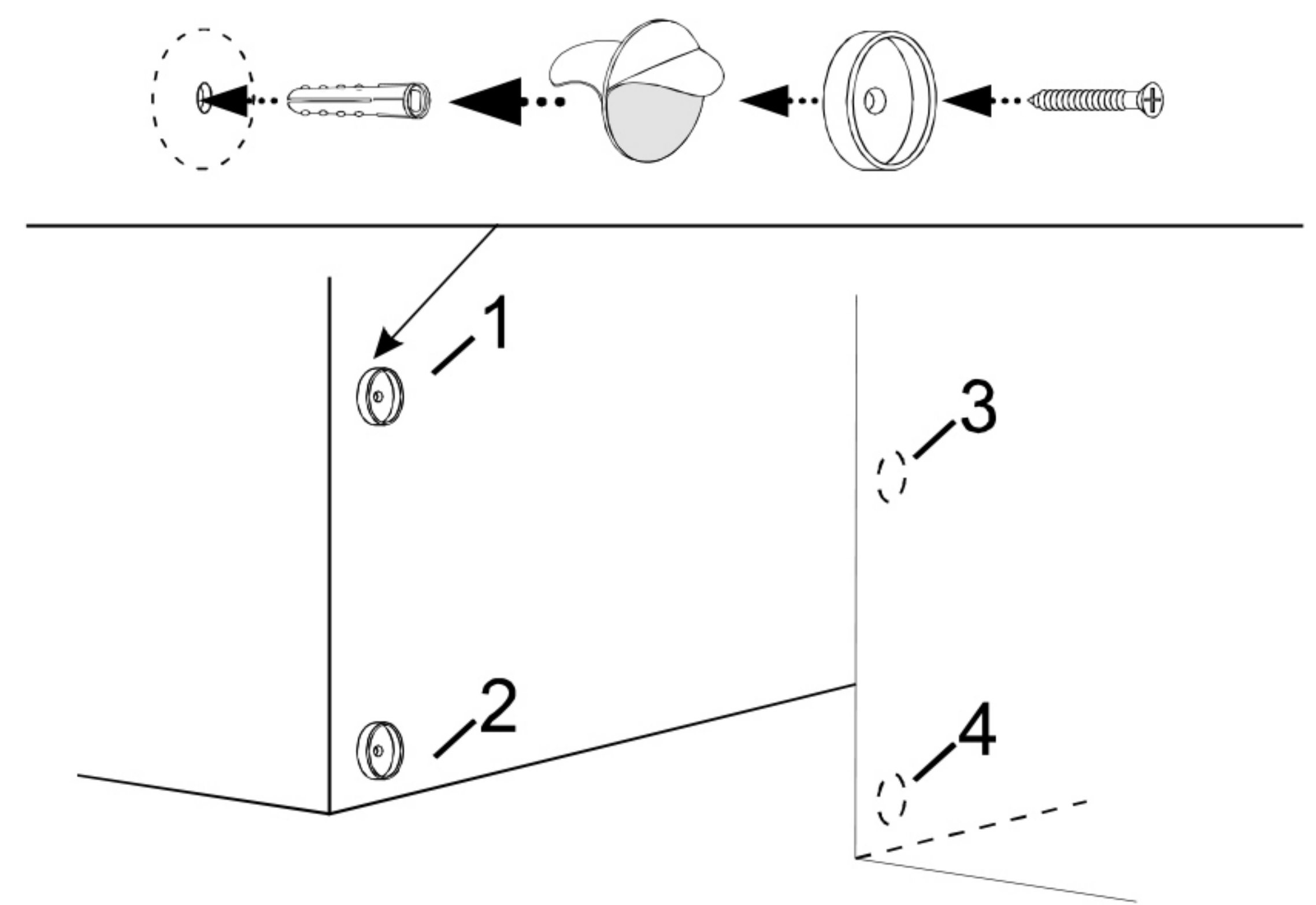

STEP4.

Tighten the top of the tension knobs by turning them clockwise at the same time

Note: Make sure the bottom of the gate frame remains completely flat on the floor.

Next, tighten the bottom of the tension knobs at the top on the same time by turning them clockwise.

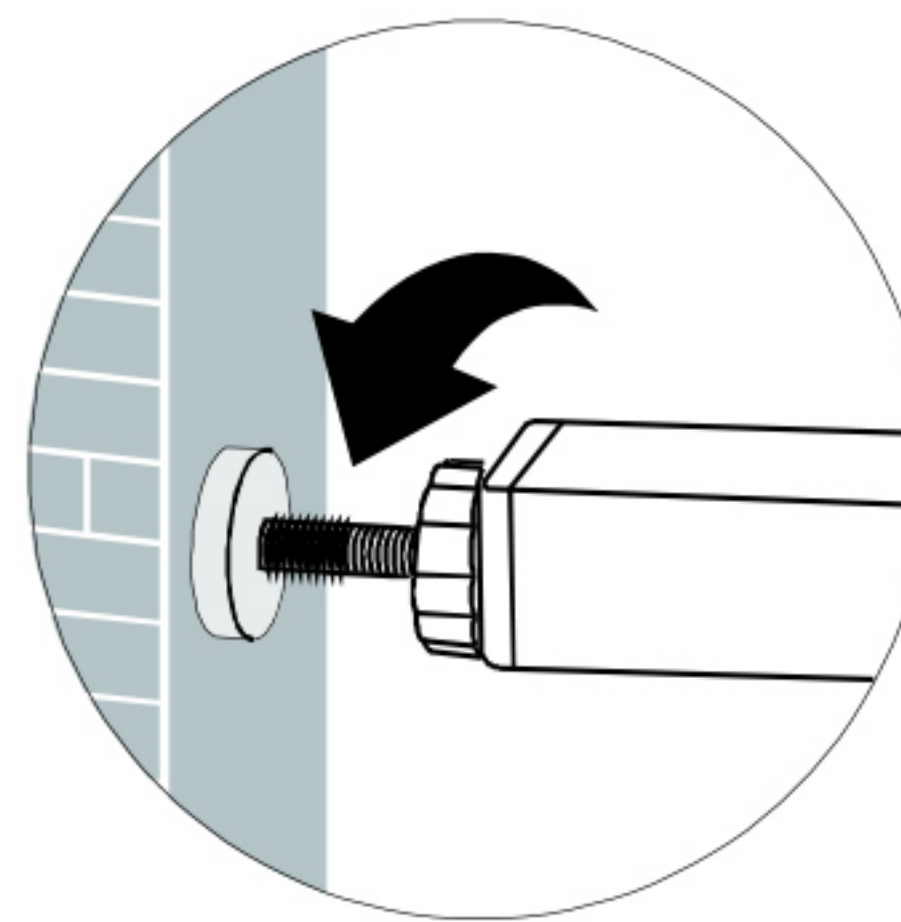

Rotate 4 bolts

Rotate the bolts until the gap about 0.2cm

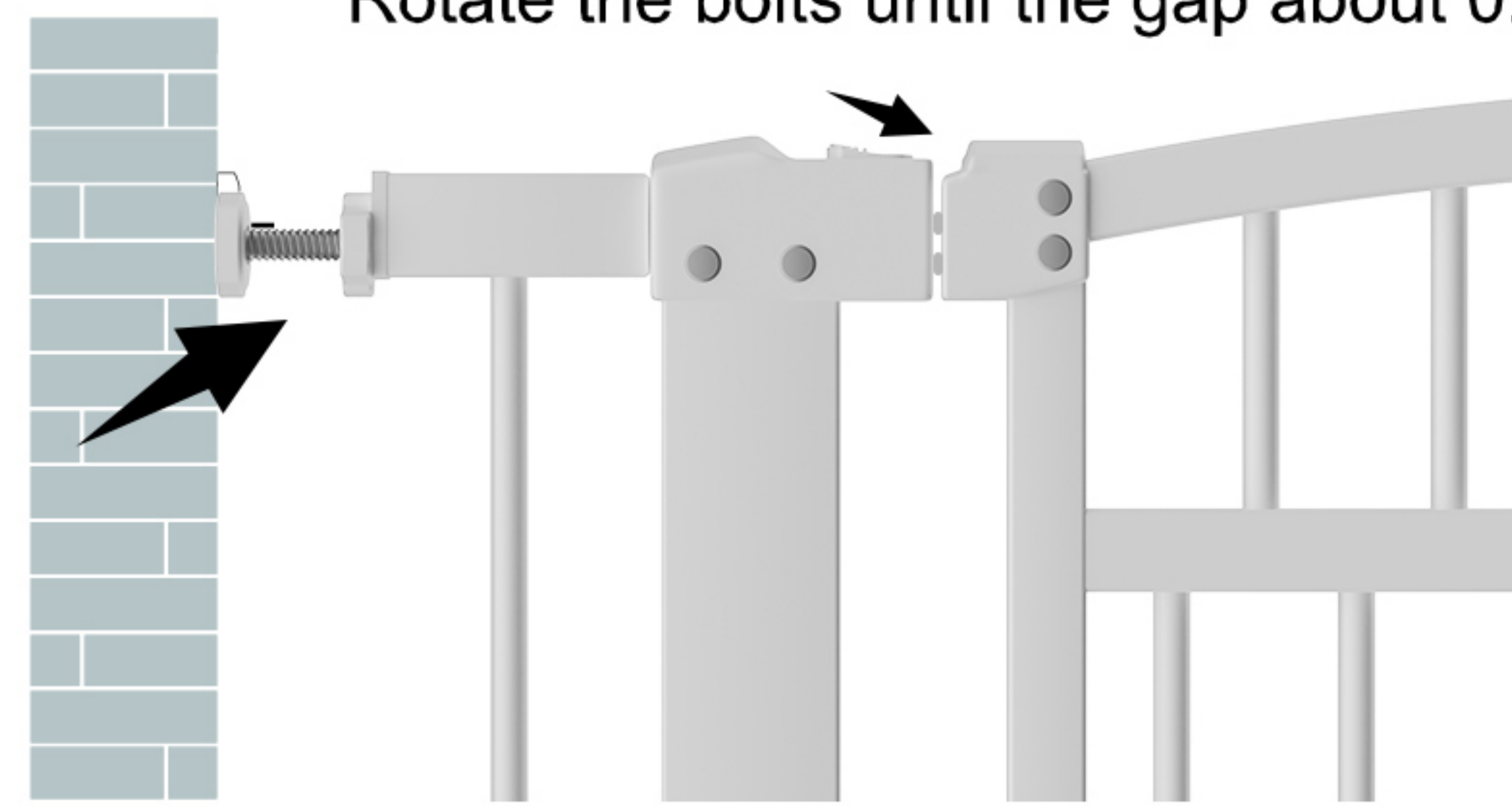

STEP5.

Cut off the belt and test the gate:

1. Push the gate to check stability.
2. Open and close the walk through gate

Pull the button to the right, then lift the gate panel UP to open.

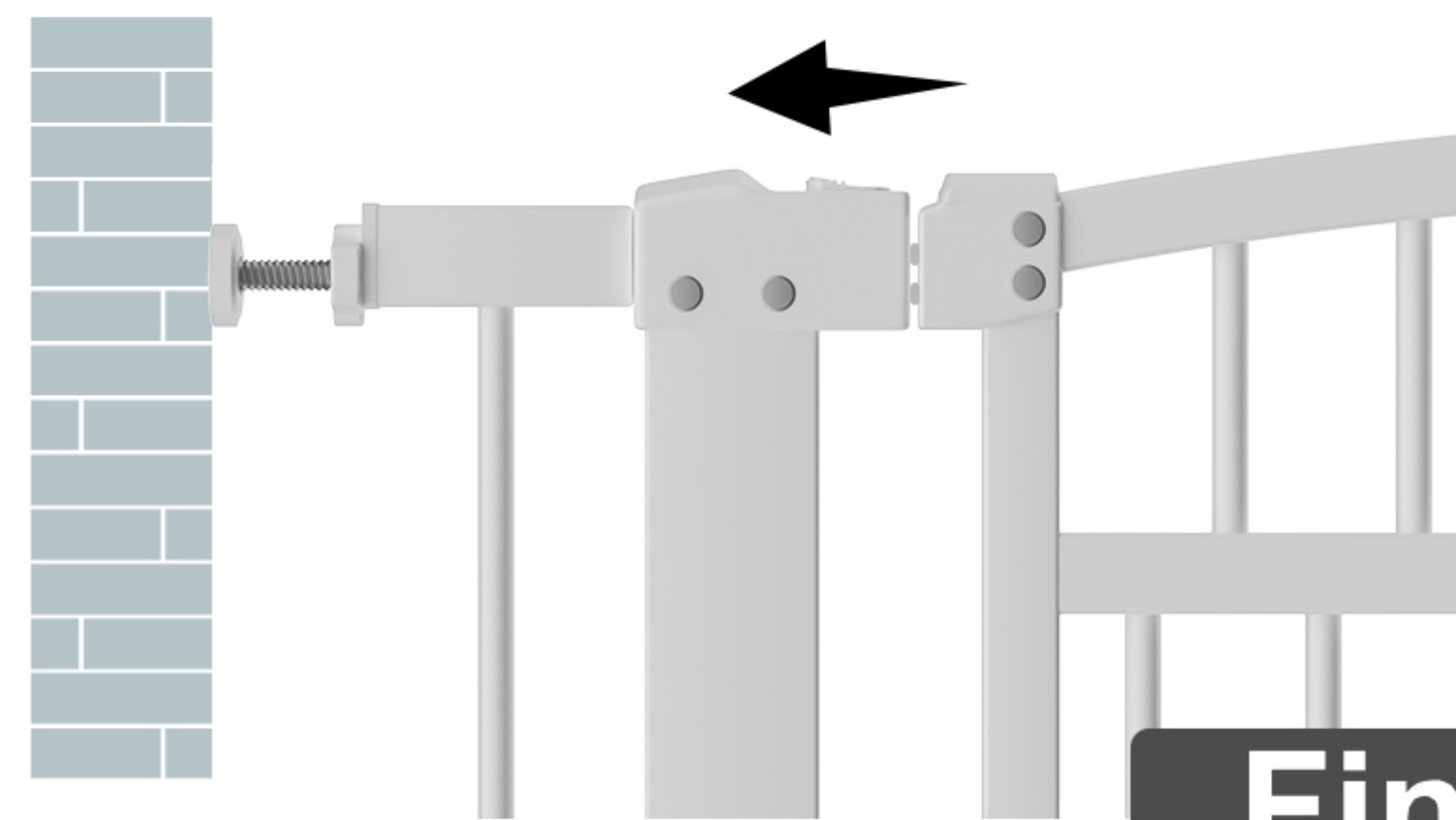

Finish

TROUBLE SHOTING

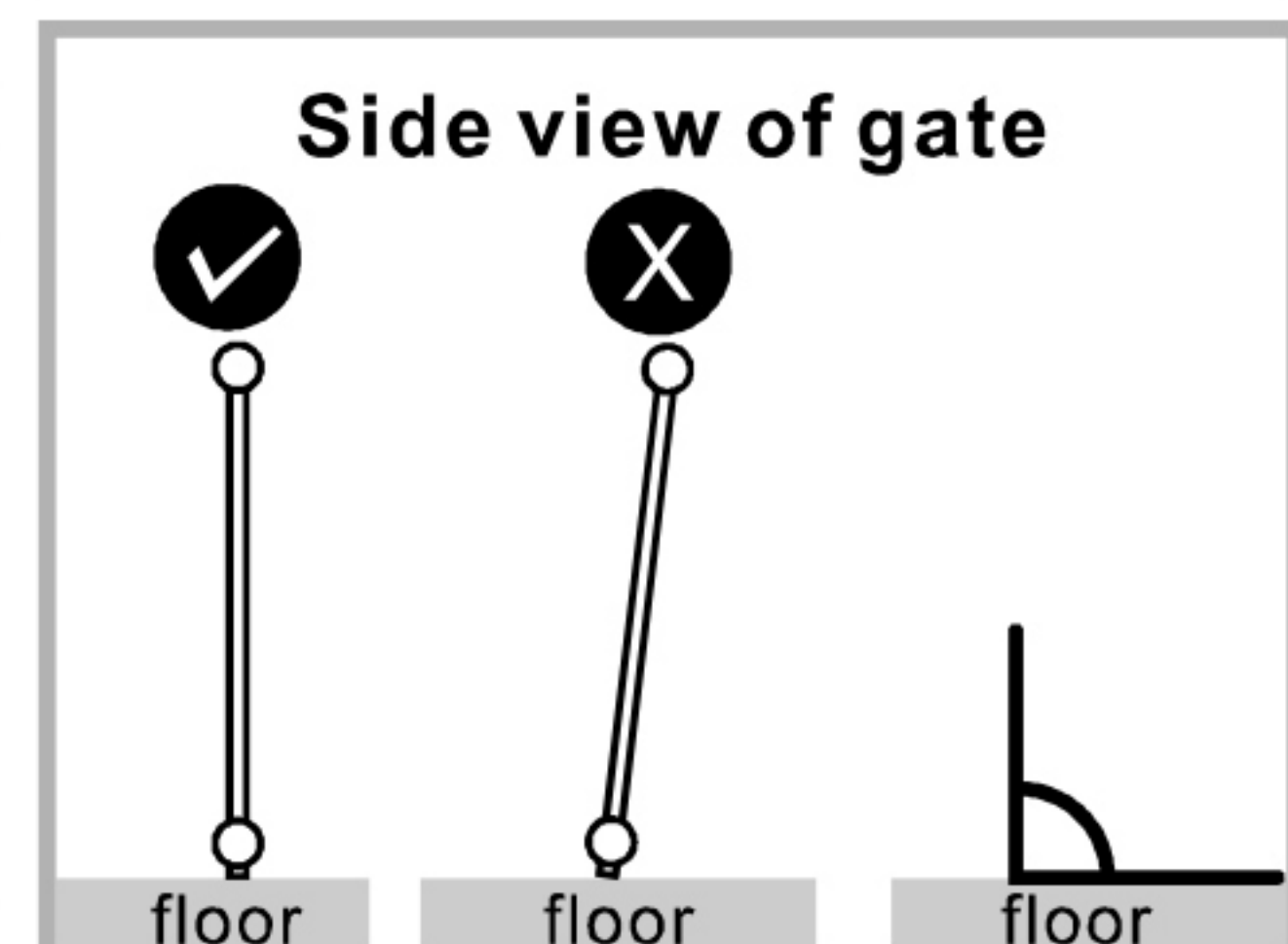
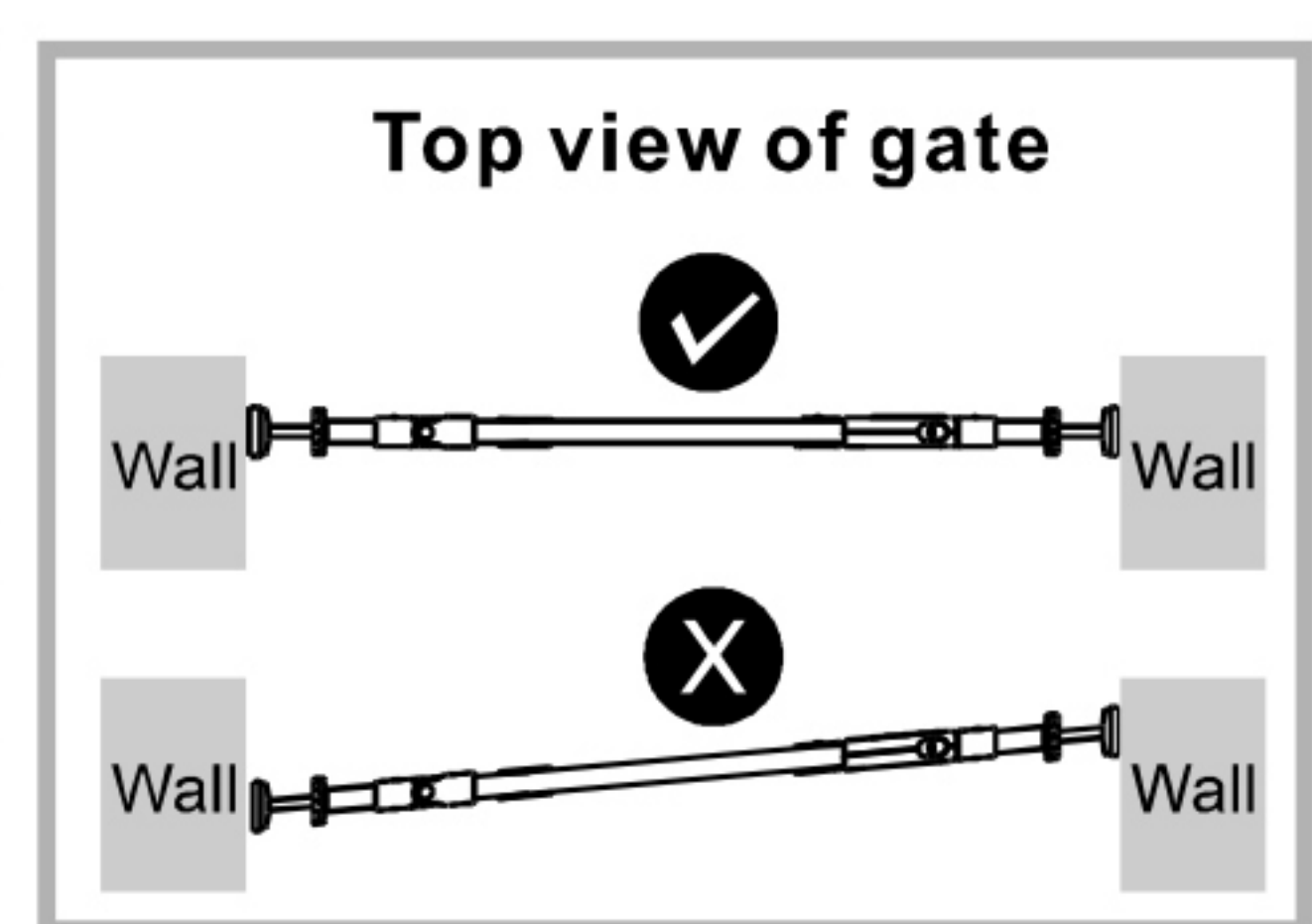
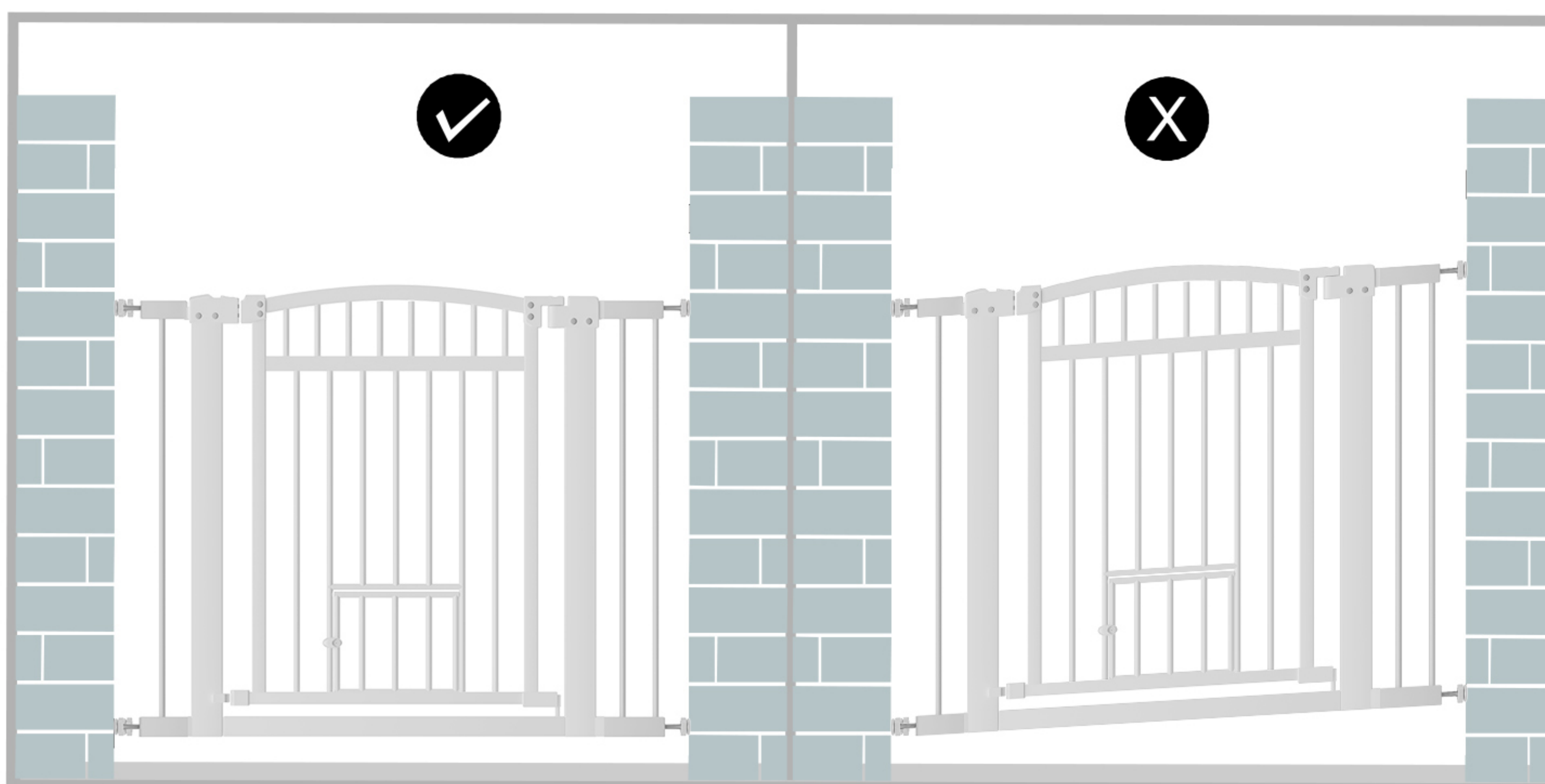

! WARNING

- To prevent serious injury or death, securely install gate or enclosure and use according to manufacturer's instructions.
- Use only with the locking mechanism securely engaged
- Stop using gate if any parts are missing or become damaged.
- ALWAYS install and use gates as directed using all required parts.
- Periodically check all fasteners to be sure they are tight and secure.
- Adult Assembly Required.
- The surfaces that the gate is to be fixed to must be suitable for the purpose and must be structurally sound.
- Indoor use only, is not to be exposed to outdoor elements.
- Install this gate away from heaters and other sources of heat.



Produits et Pièces

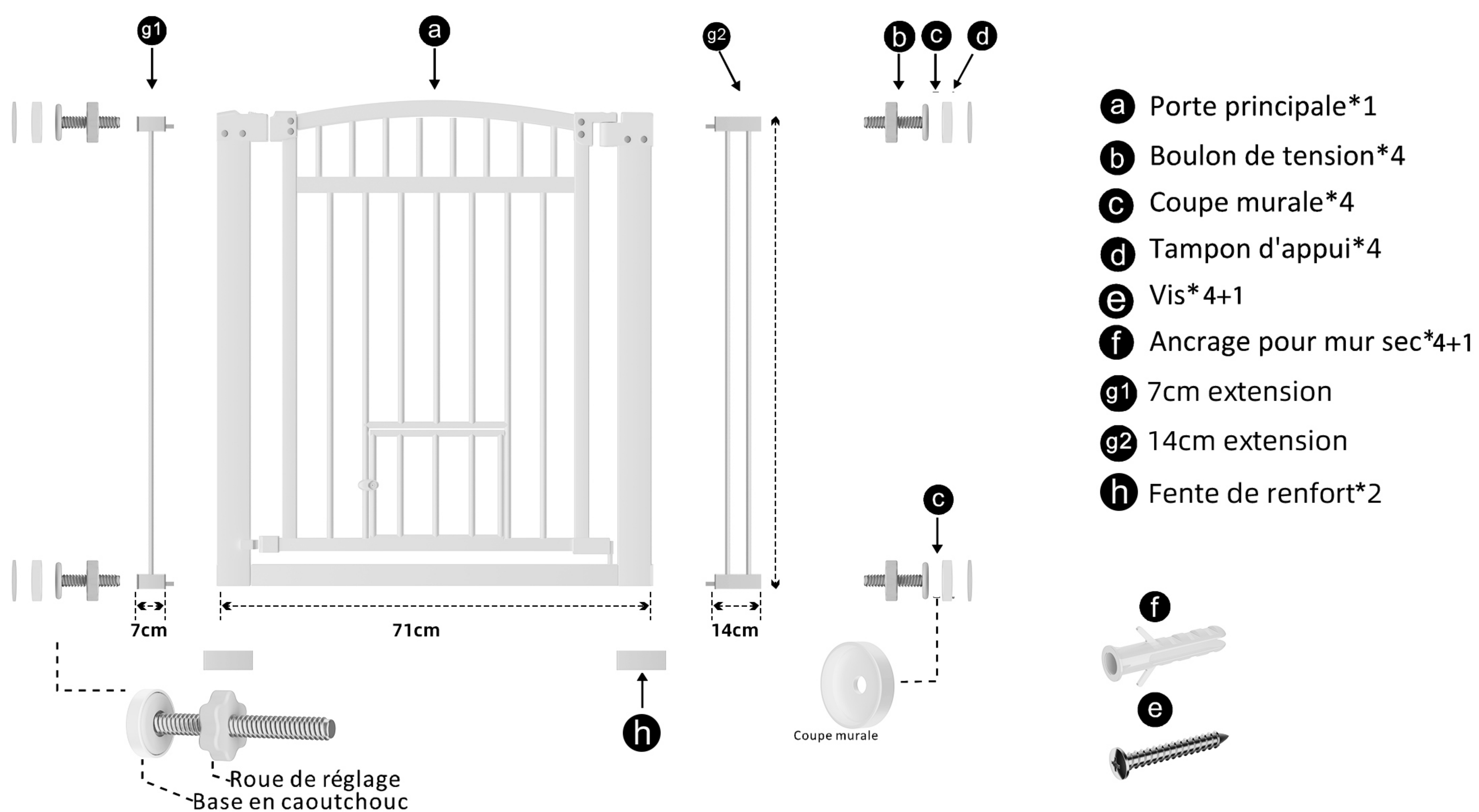

L'image est fournie à titre de référence uniquement, veuillez vous référer à l'objet en tant que norme.



AVERTISSEMENT : Cet emballage contient de petites pièces et des pointes acérées dans son état non assemblé. Tenir hors de portée des enfants. L'assemblage doit être effectué par un adulte.

Avertissement :
Pour faciliter votre installation, ne coupez pas la courroie avant la fin de l'installation ! L'écart de la porte n'est PAS un problème ! Il sera réduit à 0,2 cm après l'installation.

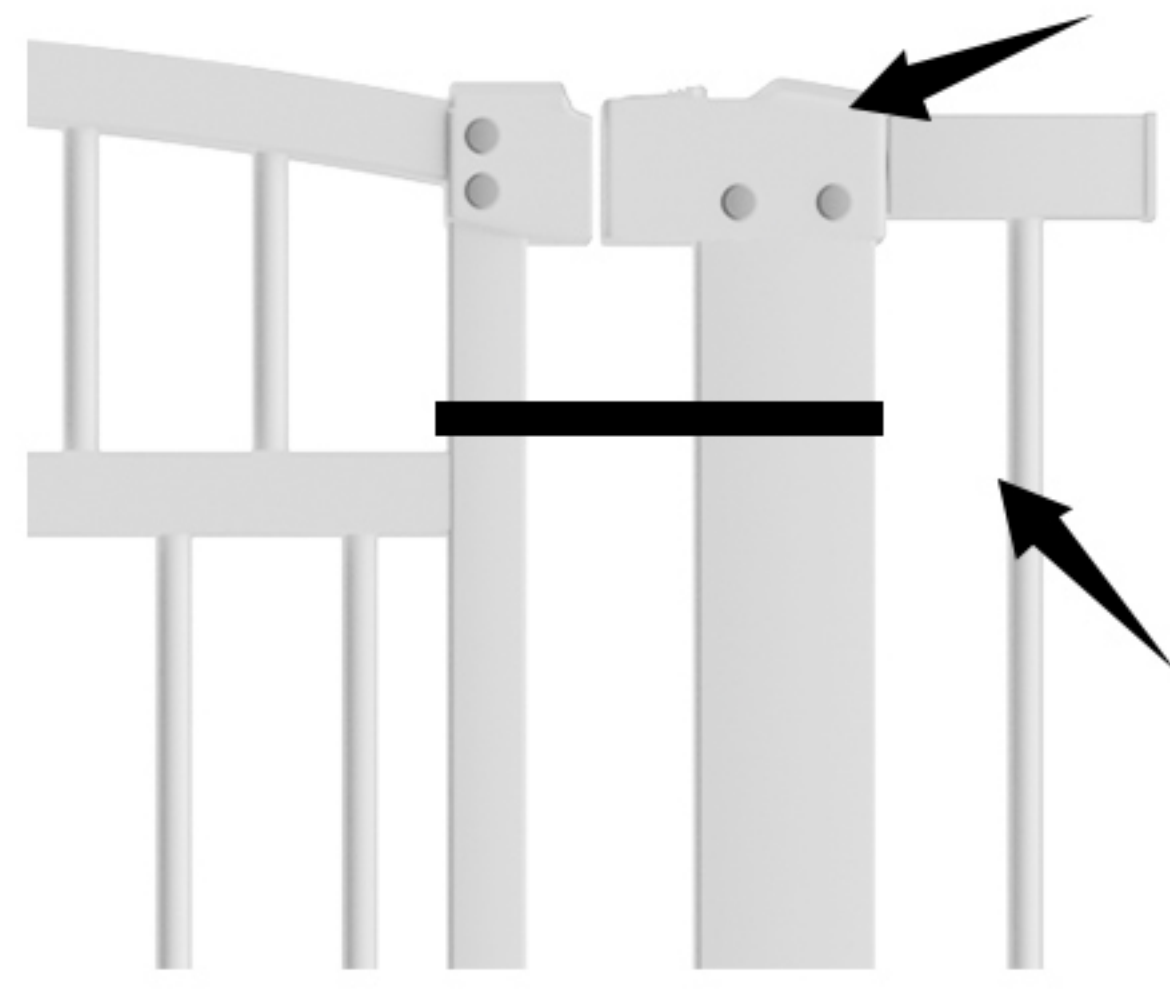

L'écart entre les portes n'est PAS un problème ! Après l'installation, il sera réduit à 0,2 cm.



NE PAS COUPER LA COURROIE
Avant la fin de l'installation



Remarque : Vissez les coupelles de montage lorsque vous utilisez la barrière dans des escaliers.



Bas de l'escalier

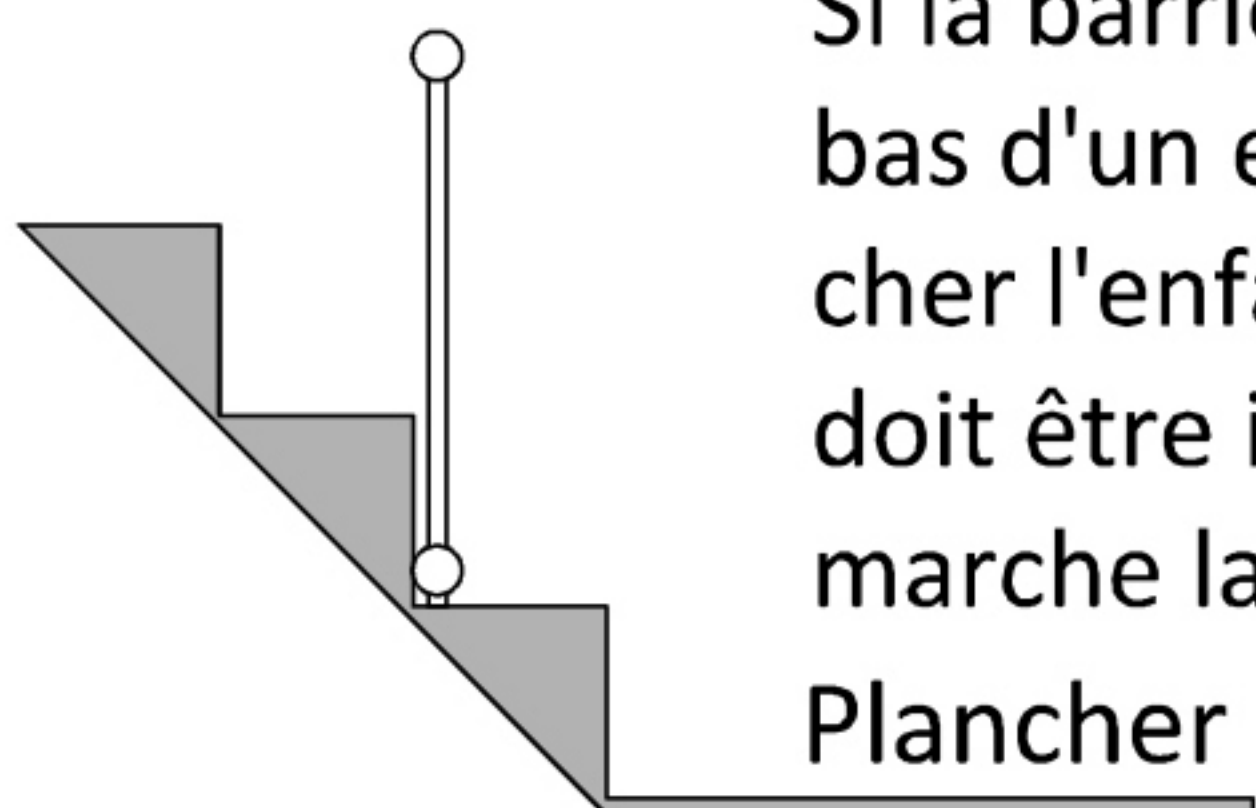

Si la barrière est utilisée au bas d'un escalier pour empêcher l'enfant de monter, elle doit être installée sur la marche la plus basse.

Plancher



Haut de l'escalier

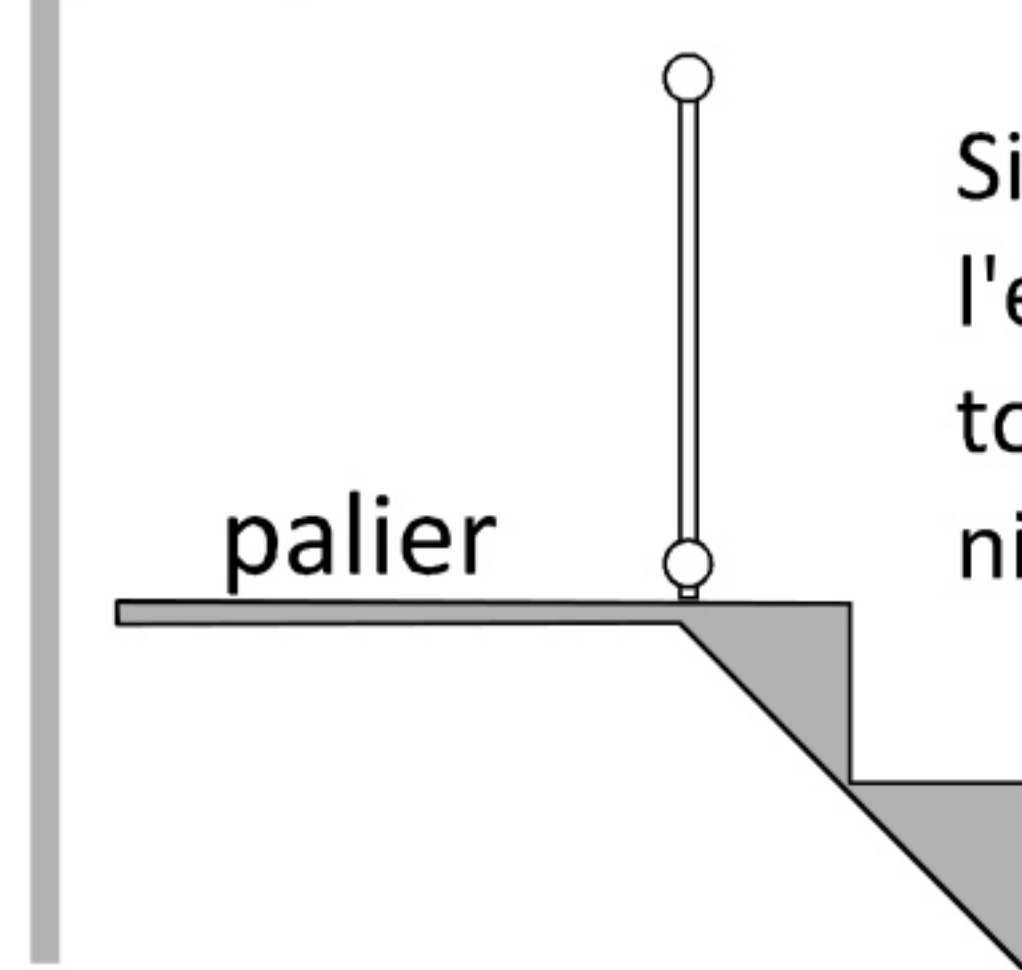

Si la barrière est utilisée en haut de l'escalier pour empêcher l'enfant de tomber dans l'escalier au-dessous du niveau de la marche supérieure.

ÉTAPE 1.

Pré-assemblez la barrière et repérez quatre points pour le perçage des trous. Maintenez la coupe murale en position et marquez le centre avec un crayon.

REMARQUE : la barrière doit reposer sur le sol. **NE laissez PAS** un espace de plus de 0,5 cm entre la barrière et le sol.

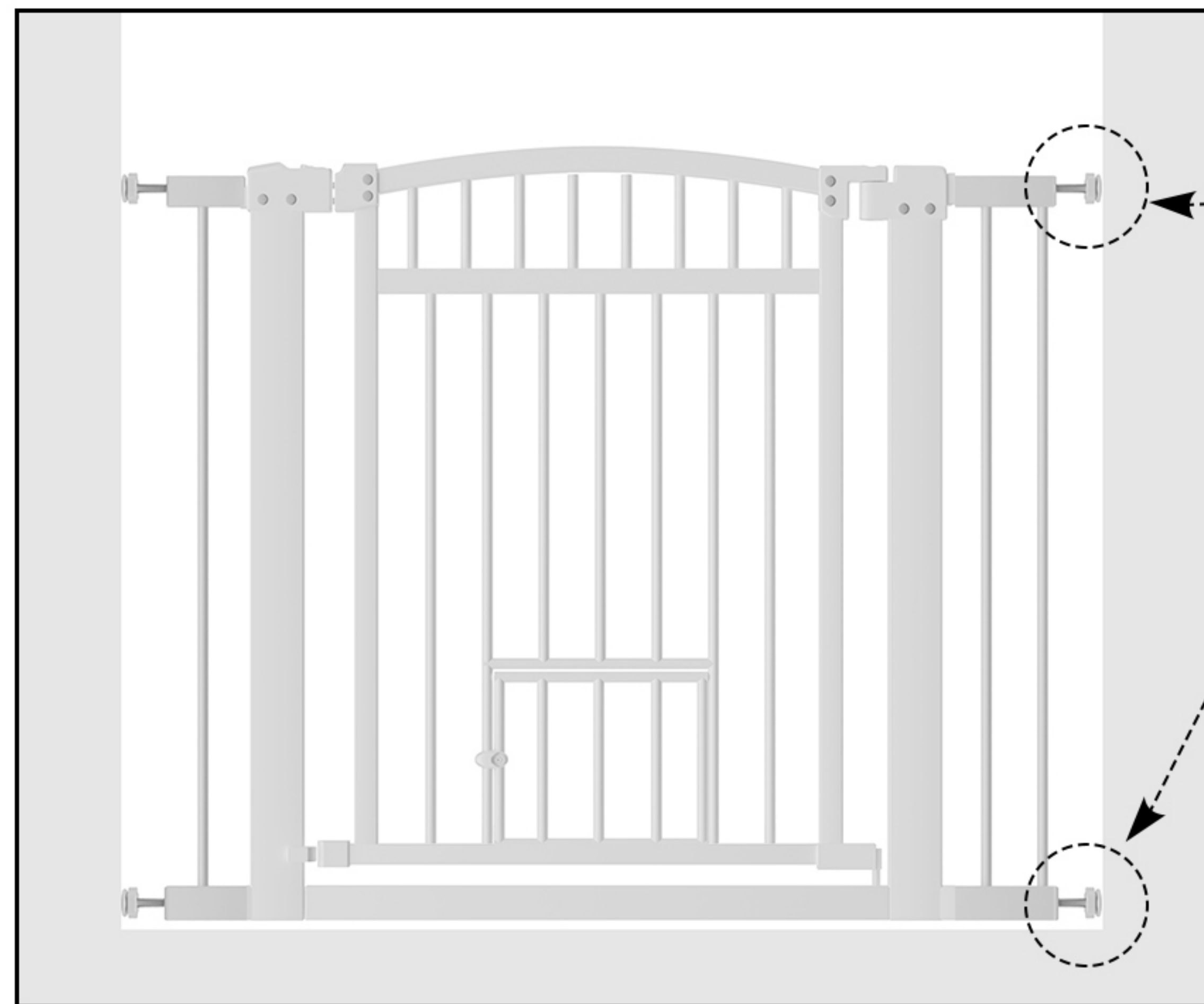
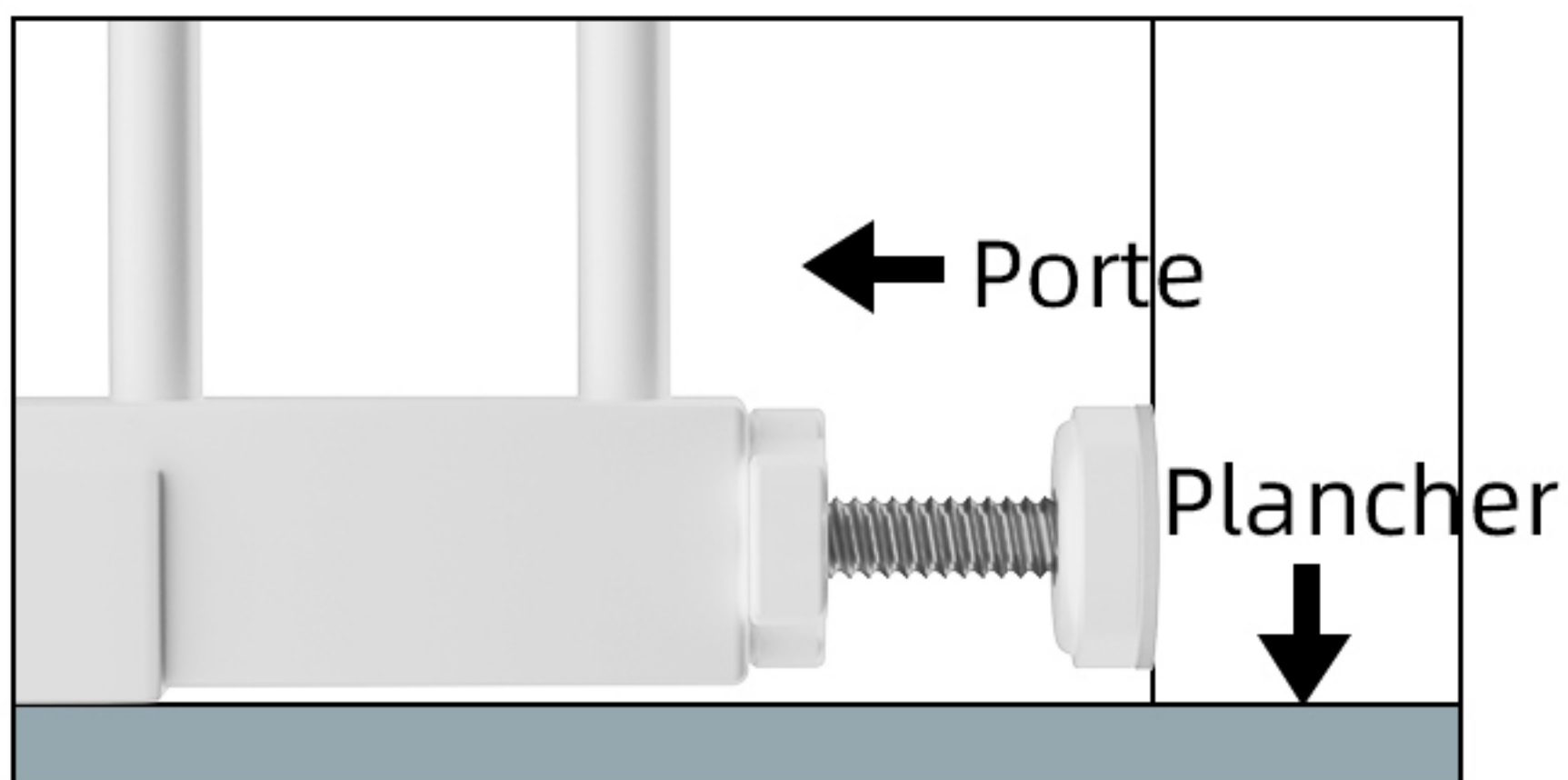

ÉTAPE 2.

Collez le tampon si vous utilisez une installation à pression. Retirez les deux côtés du tampon adhésif et collez 4 tampons sur 4 supports muraux. Les supports muraux recouvrent ensuite les boulons.

CONSEIL : si vous ne craignez pas d'endommager les murs, passez cette étape.

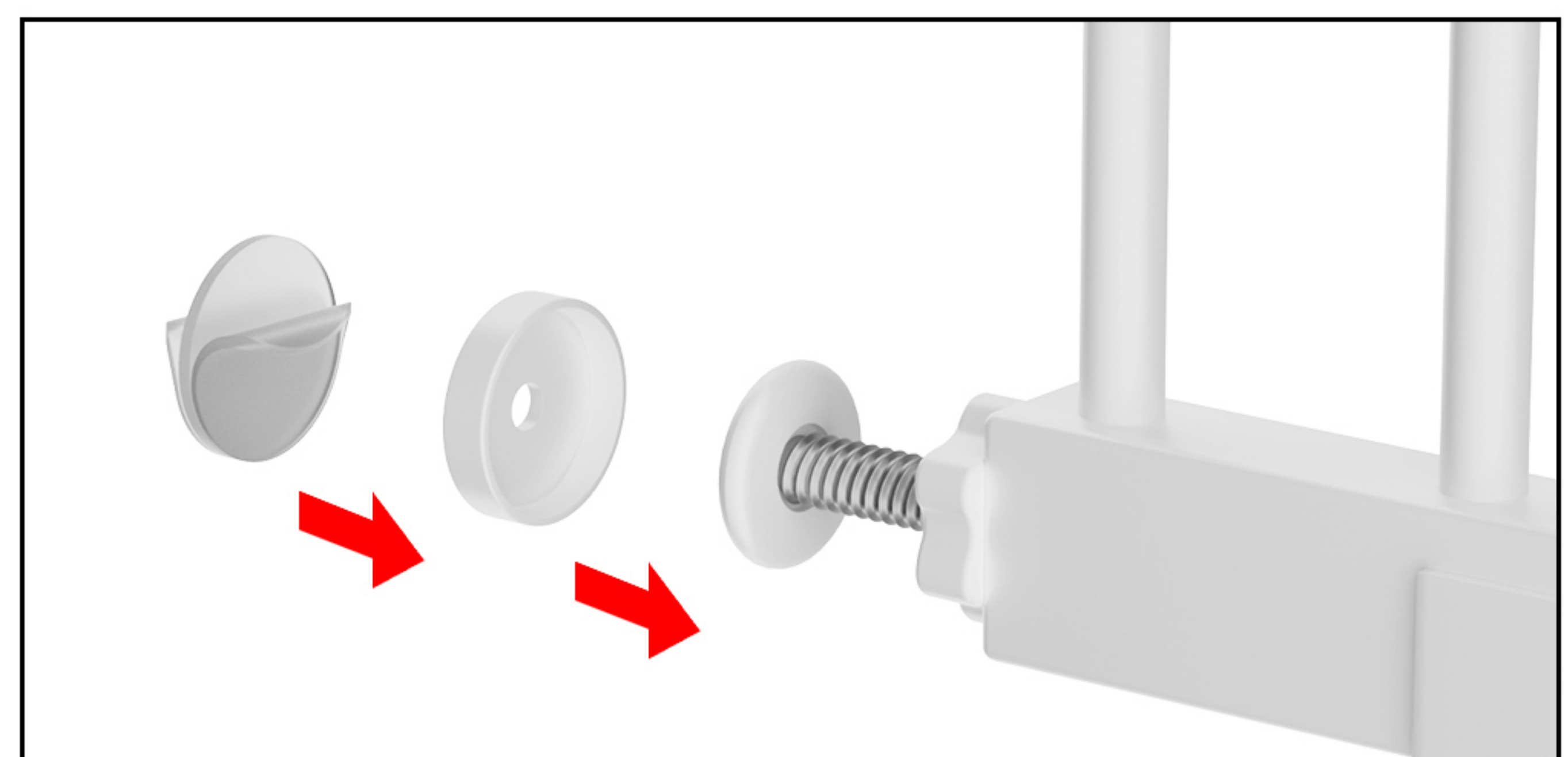

ÉTAPE 3.

Percez un trou aux 4 emplacements marqués, puis placez la cheville pour cloison sèche (g) et utilisez la vis (f) et la coupelle murale (d).

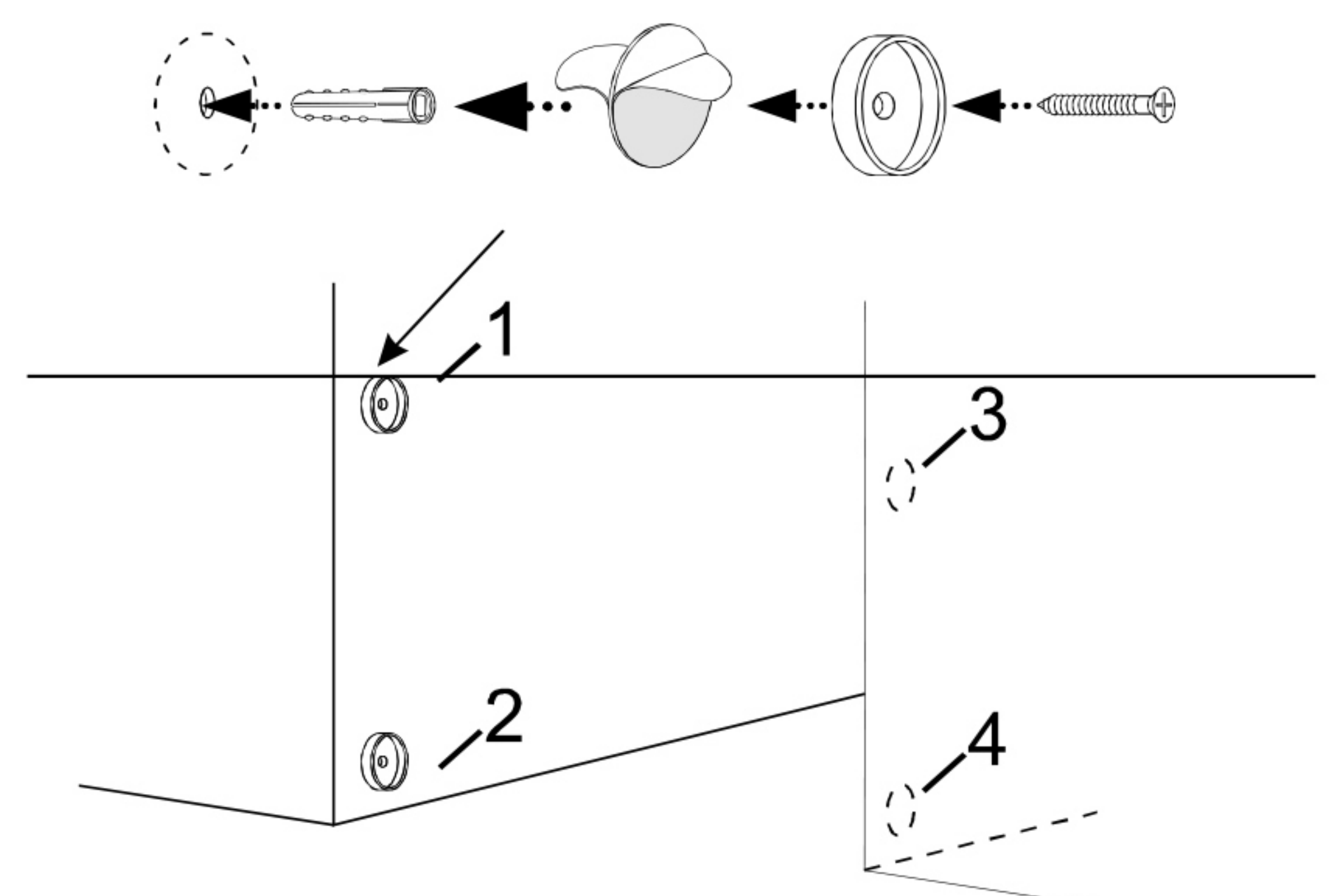
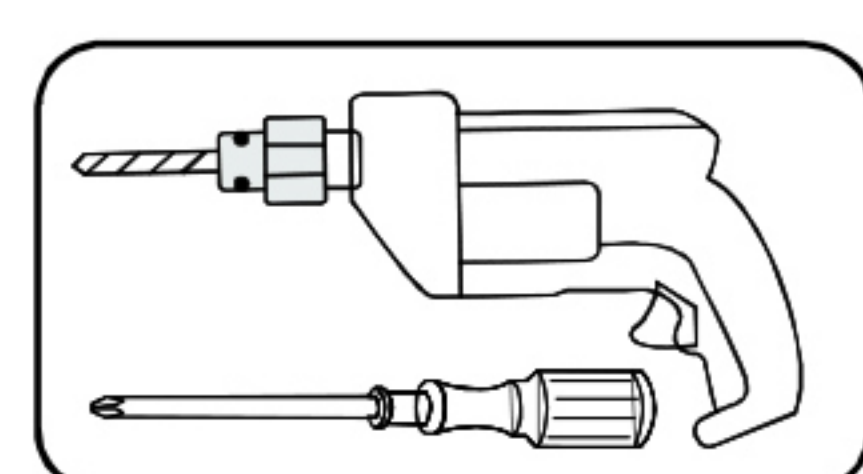
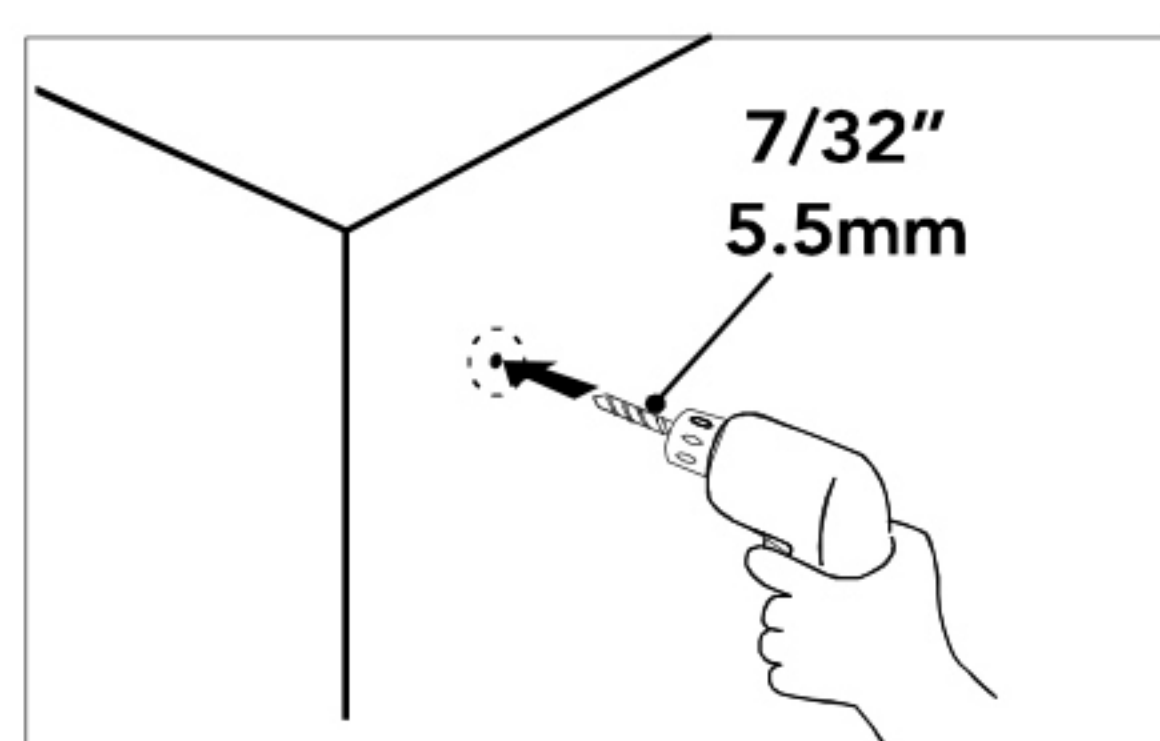

L'outil d'installation n'est pas fourni avec le produit.

ÉTAPE 4.

Serrez le haut des boutons de tension en les tournant en même temps dans le sens des aiguilles d'une montre.

Remarque : Assurez-vous que le bas du cadre de la barrière reste complètement plat sur le sol.

Ensuite, serrez simultanément les boutons de tension du bas et du haut en les tournant dans le sens des aiguilles d'une montre.

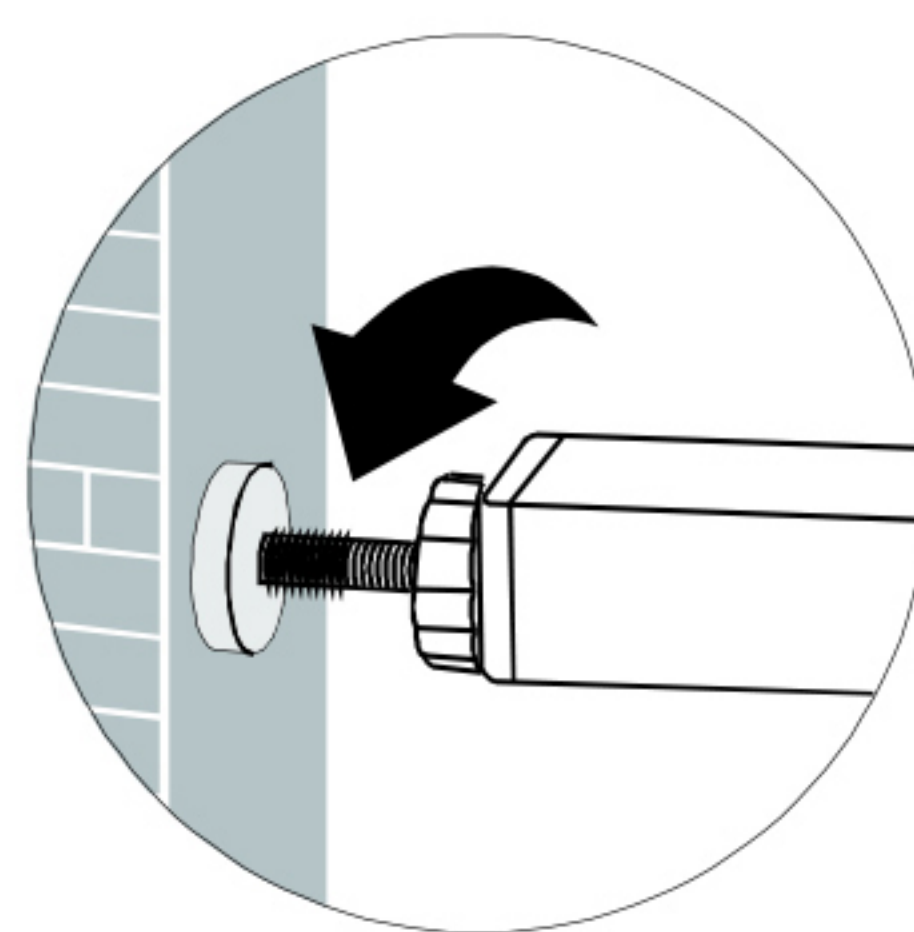

Faites tourner les 4 boulons.

Tournez les boulons jusqu'à ce que l'écart soit d'environ 0,2 cm.

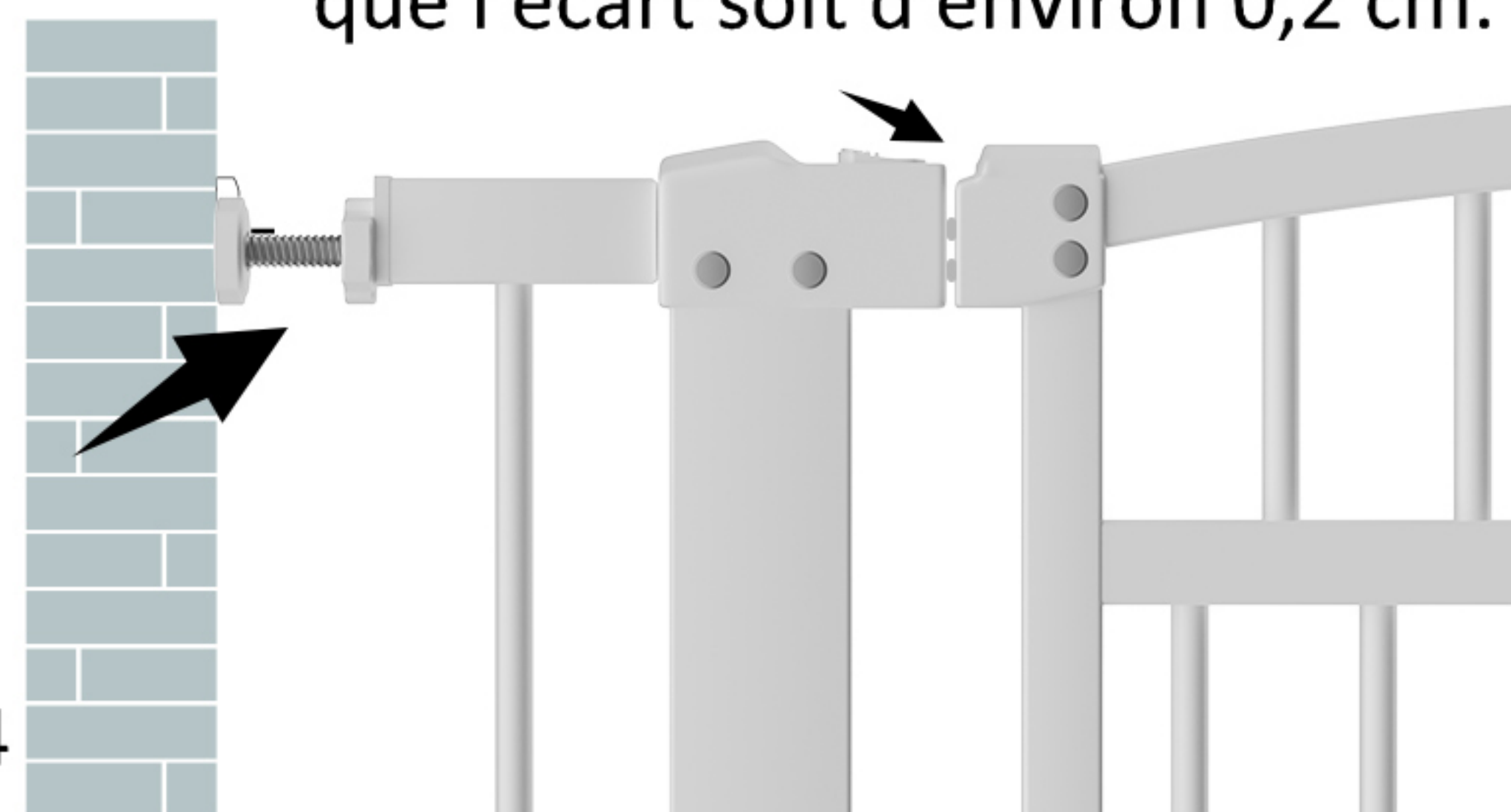
**ÉTAPE 5.**

Coupez la courroie et testez la barrière :

1. Poussez la barrière pour vérifier sa stabilité.

2. Ouvrez et fermez la porte de passage

Méthode d'Ouverture :

Tirez le bouton vers la droite, puis soulevez le panneau de la barrière vers le HAUT pour l'ouvrir.

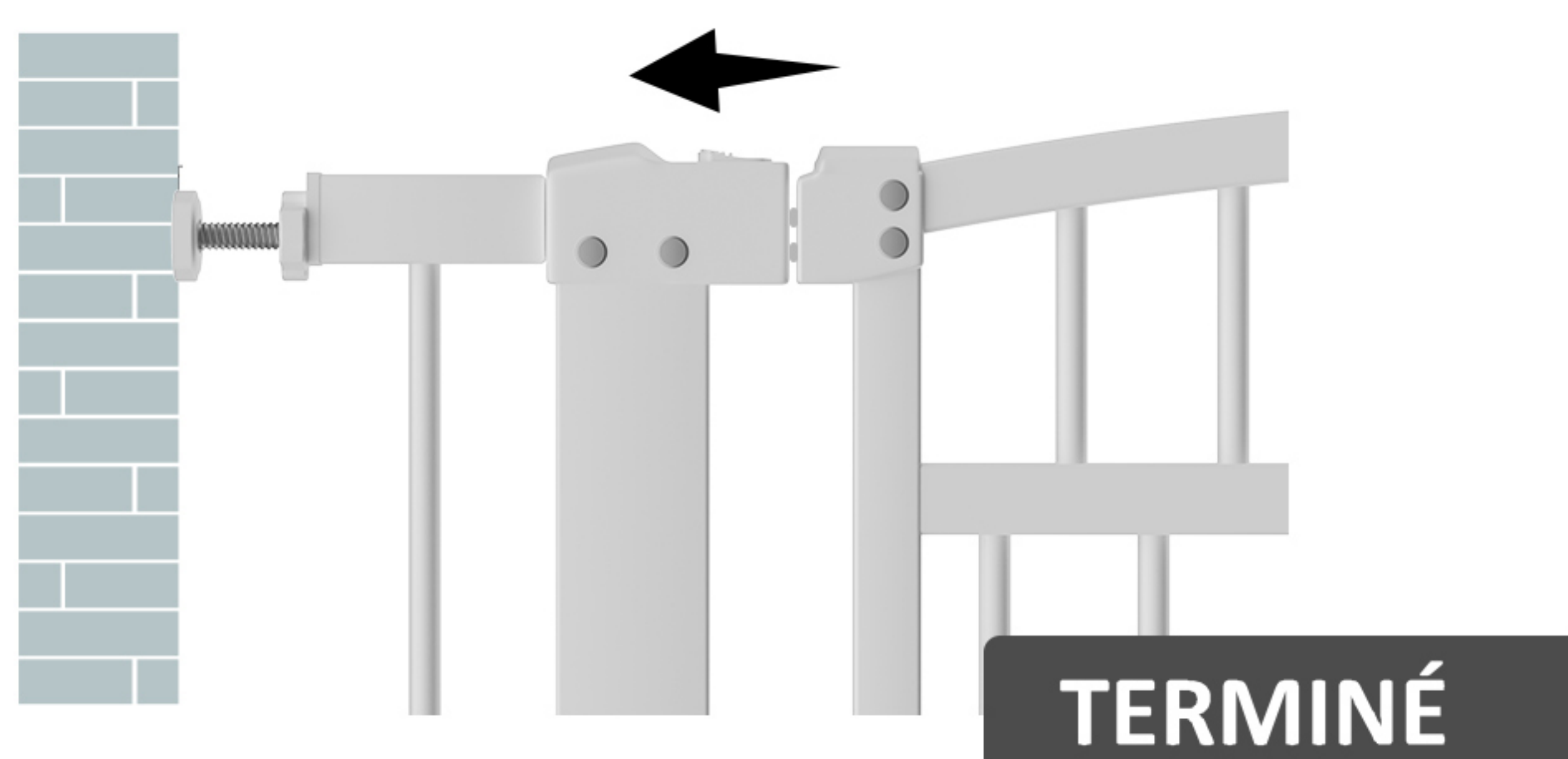
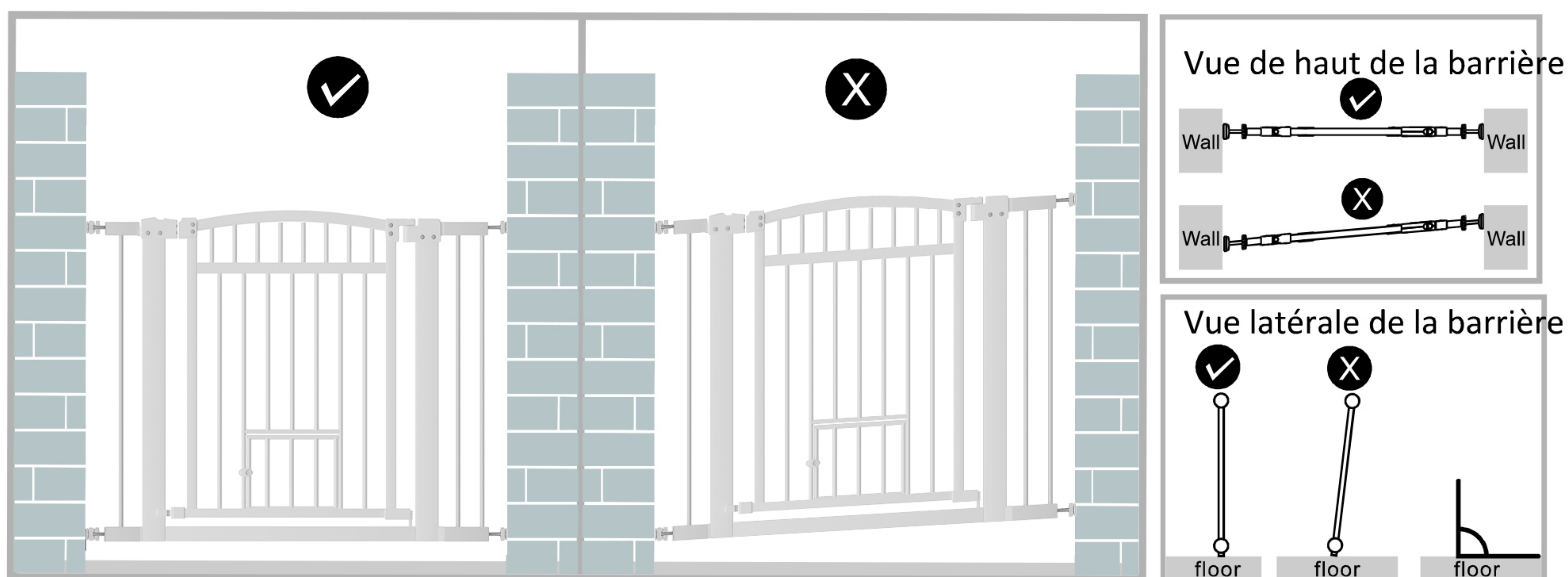
**DÉPANNAGE****AVERTISSEMENT**

- Pour éviter toute blessure grave ou mortelle, installer solidement la barrière ou l'enceinte et l'utiliser conformément aux instructions du fabricant.
- N'utiliser que si le mécanisme de verrouillage est bien enclenché. Cesser d'utiliser la barrière si des pièces manquent ou sont endommagées.
- TOUJOURS installer et utiliser les barrières conformément aux instructions en utilisant toutes les pièces requises.
- Vérifiez périodiquement toutes les fixations pour vous assurer qu'elles sont bien serrées et sécurisées.
- L'assemblage doit être effectué par un adulte.
- Les surfaces sur lesquelles la barrière doit être fixée doivent convenir à cet usage et être structurellement solides.
- L'utilisation à l'intérieur uniquement, ne doit pas être exposée aux éléments extérieurs.
- Installez cette barrière loin des chauffages et autres sources de chaleur.



Producto & Piezas

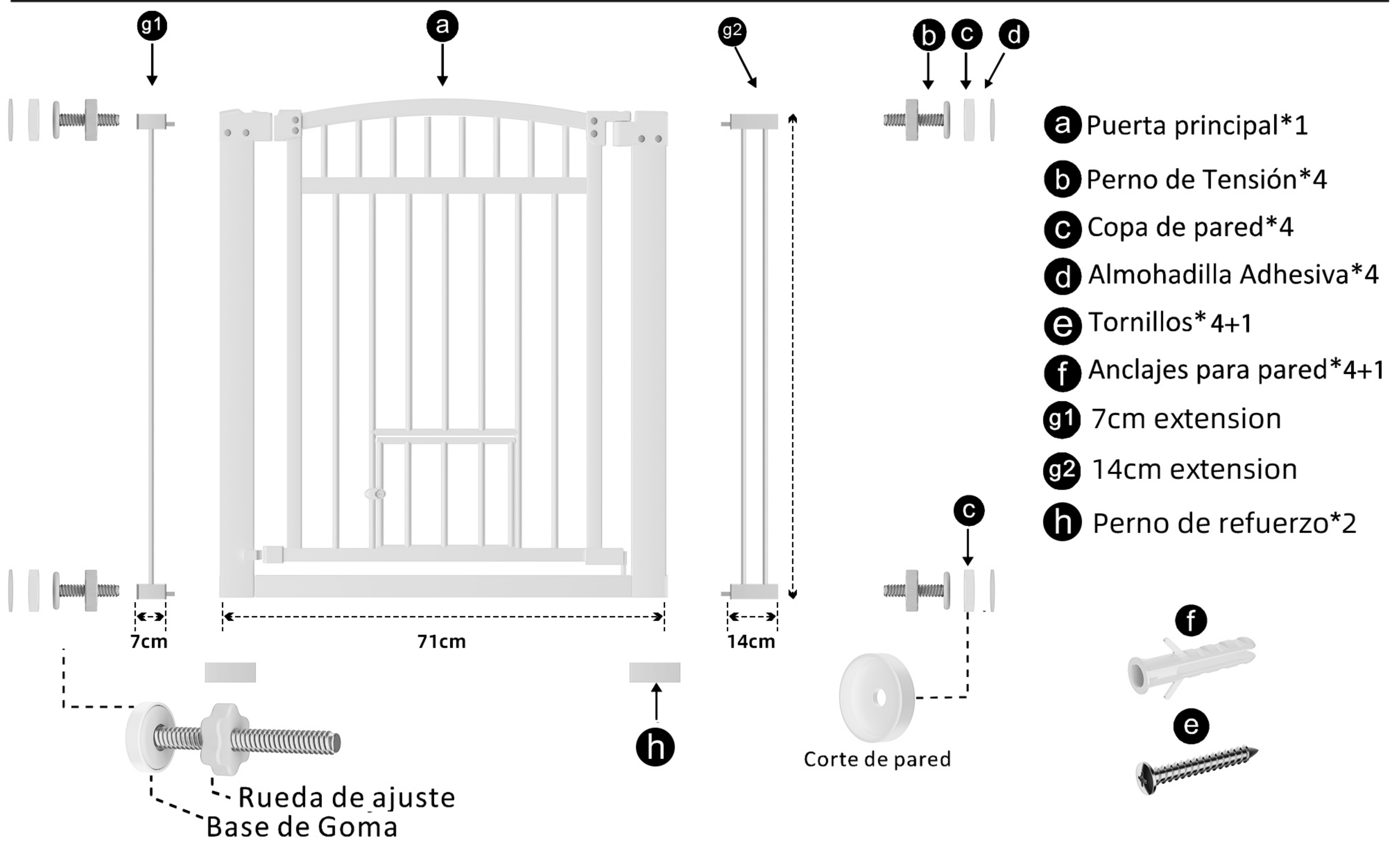

La imagen es sólo como referencia, el producto real puede ser diferente.



ADVERTENCIA: Este paquete con **ene** piezas pequeñas y puntas afiladas sin ensamblar. Manténgalo fuera del alcance de los niños. El ensamblaje debe realizarse por un adulto.

Advertencia:

Para facilitar su instalación, ¡no corte la cinta antes de que se complete la instalación! ¡La brecha de la puerta NO es un defecto! Se disminuirá a 0,2 cm después de la instalación.

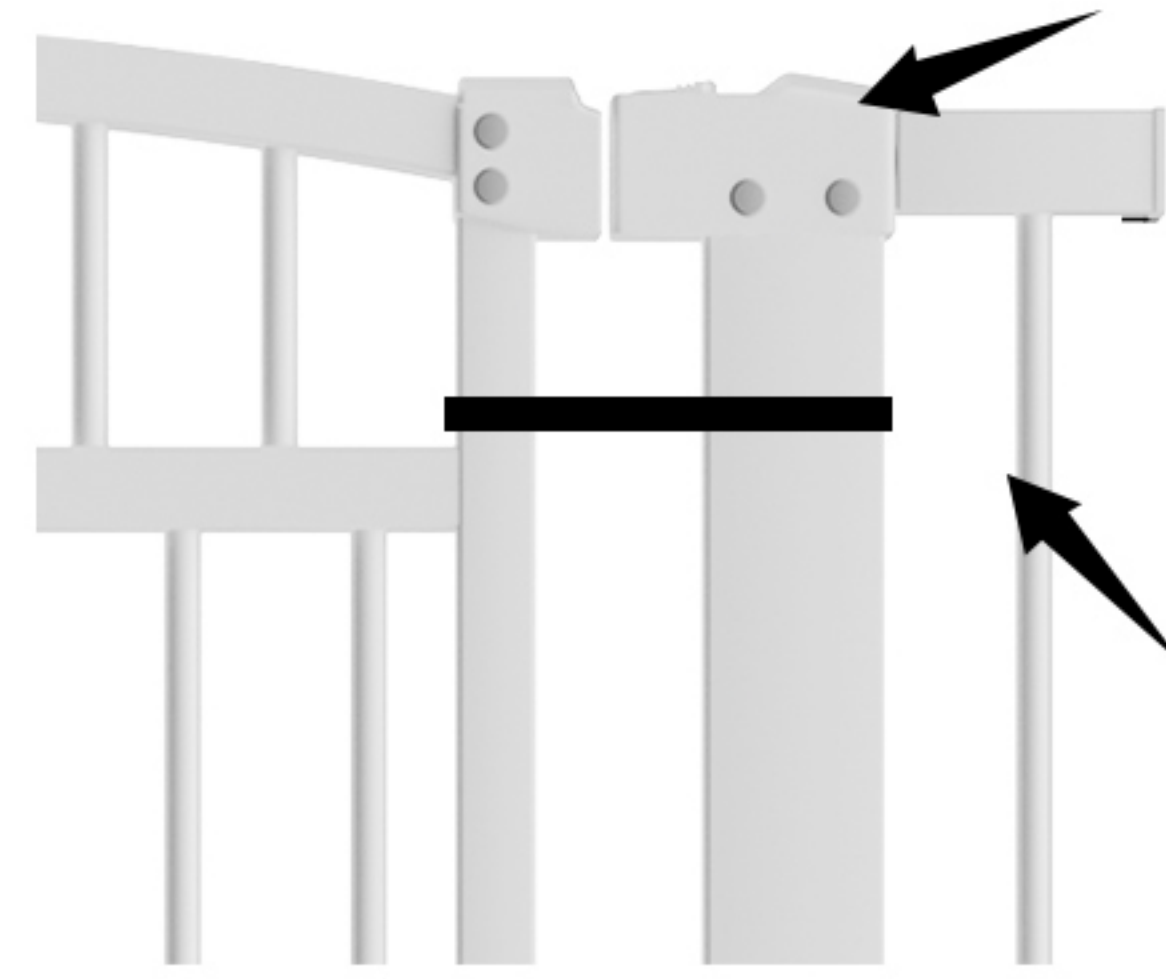

La brecha de la puerta NO es un defecto, se disminuirá a 0,2 cm después de la instalación.



CORTE LA CINTA

antes de que se complete la instalación.



Nota: Atornille las copas de montaje cuando se utiliza la puerta en las escaleras.



Parte inferior de escaleras

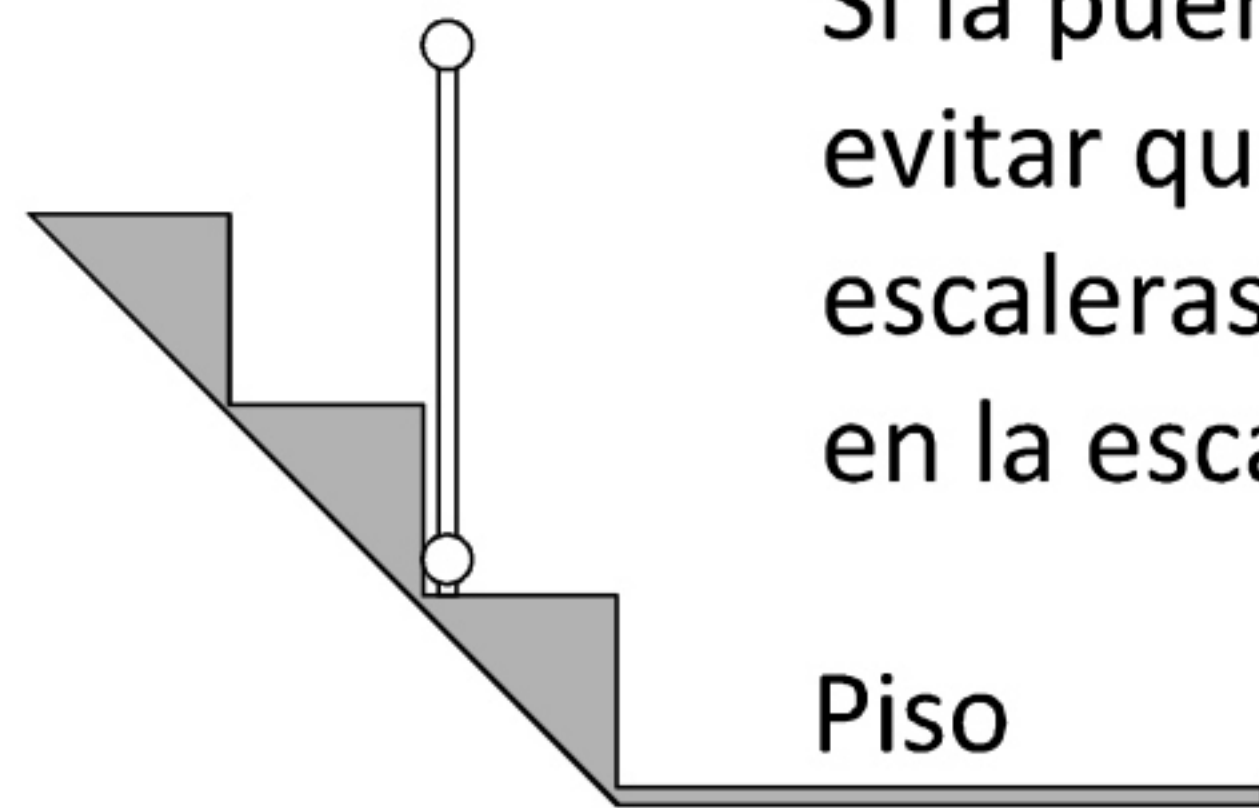

Si la puerta se usa para evitar que el niño suba las escaleras, se debe colocar en la escalera más baja.



Parte superior de escaleras

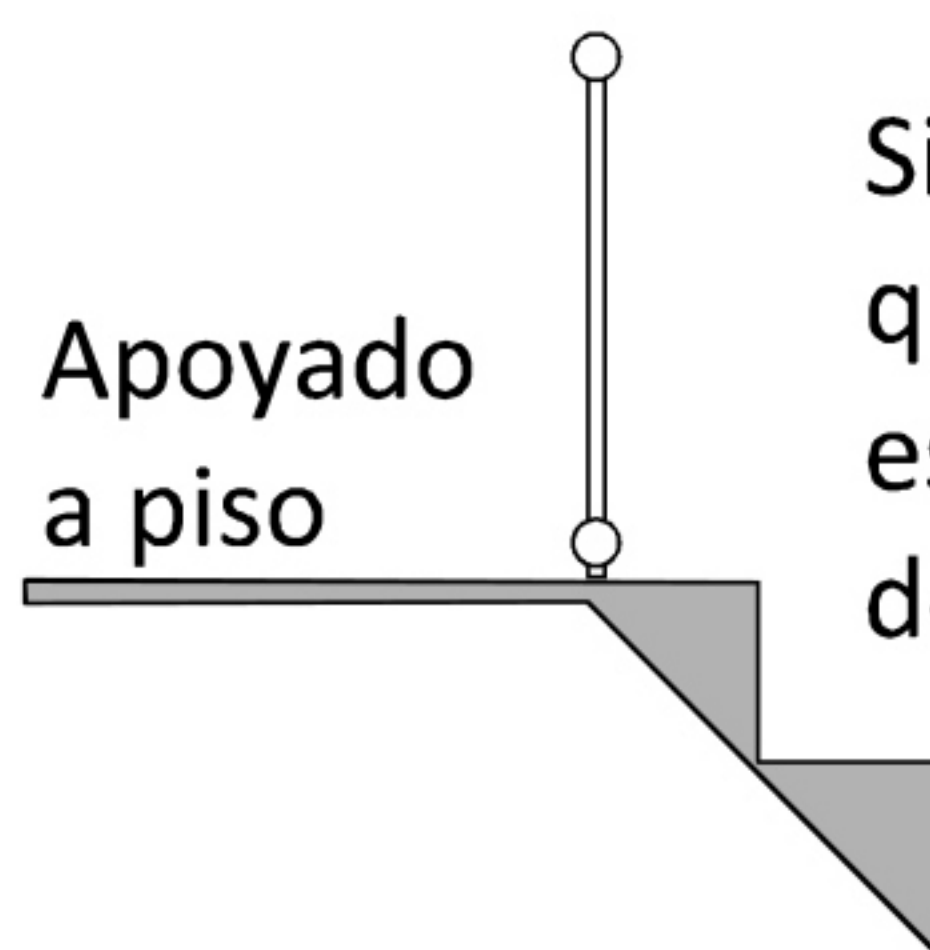

Si la puerta se usa para evitar que el niño se caiga por las escaleras, se debe colocar debajo la escalera superior.

PASO 1.

Pre-ensamble la puerta y determine los cuatro puntos para la perforación. Sostenga la copa de pared en su posición y marque el centro con un lápiz.

POR FAVOR TENGA EN CUENTA: La puerta debe estar apoyada en el piso. El espacio entre la puerta y el piso no debe ser más de 0,5 cm.

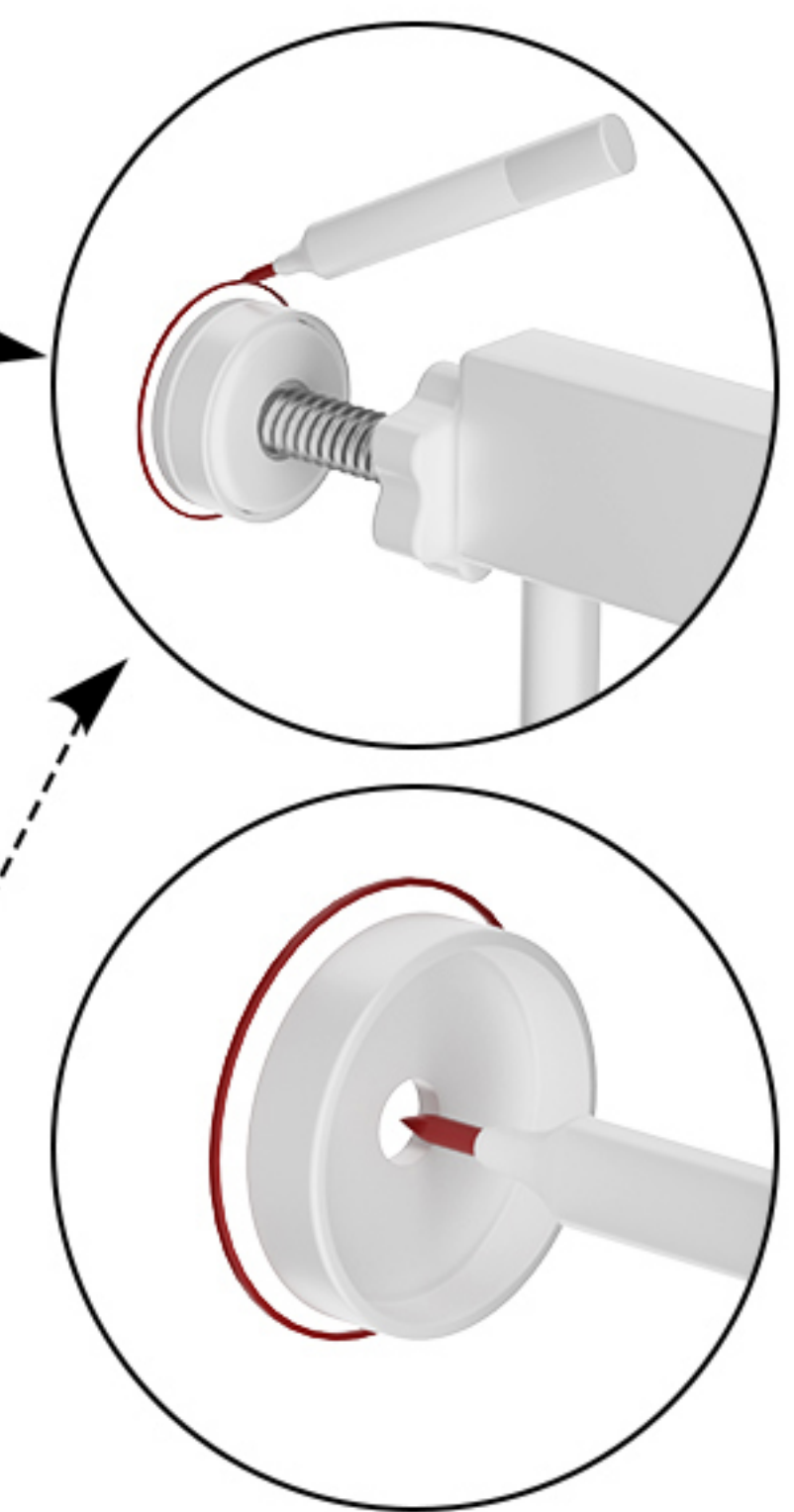
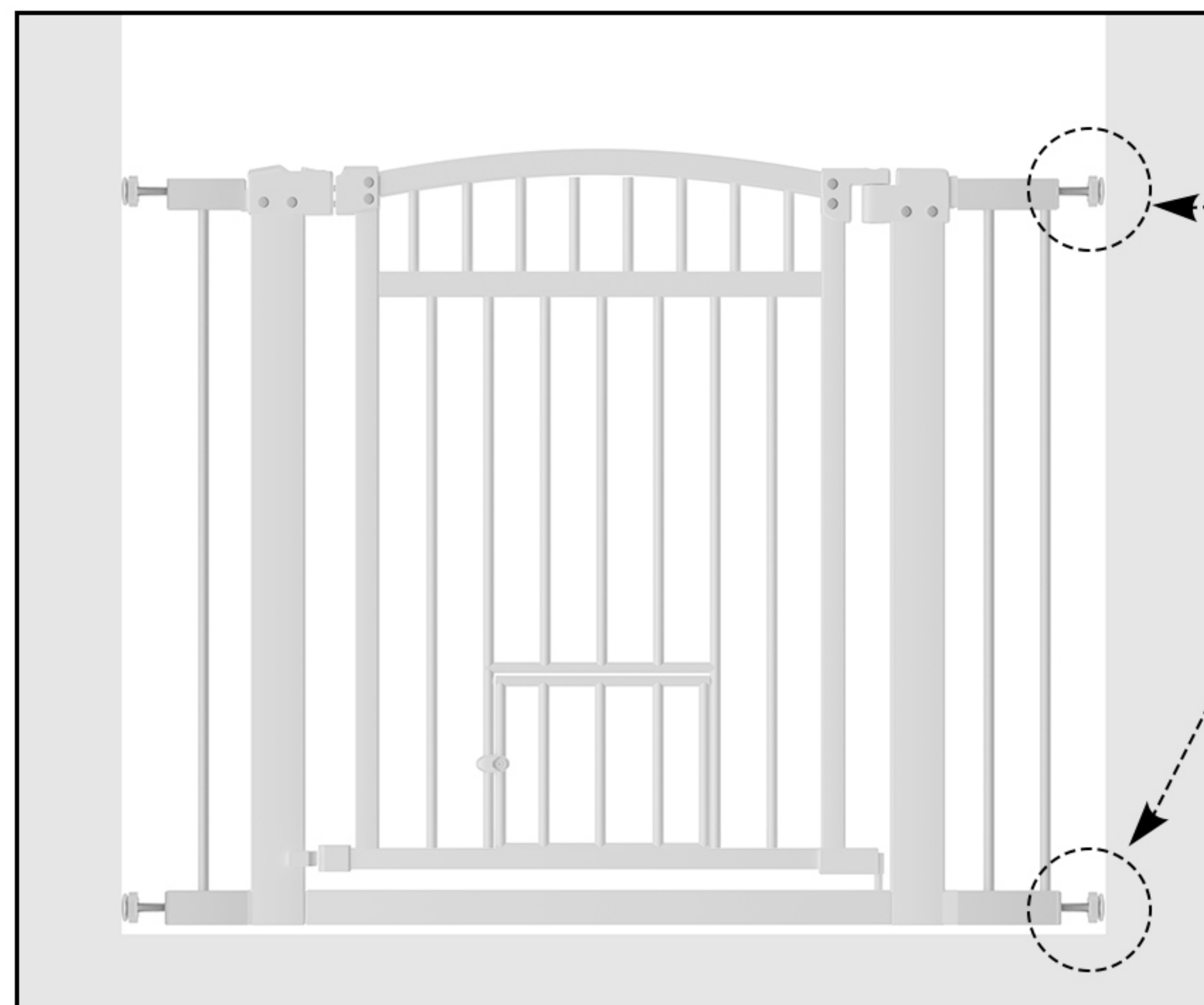
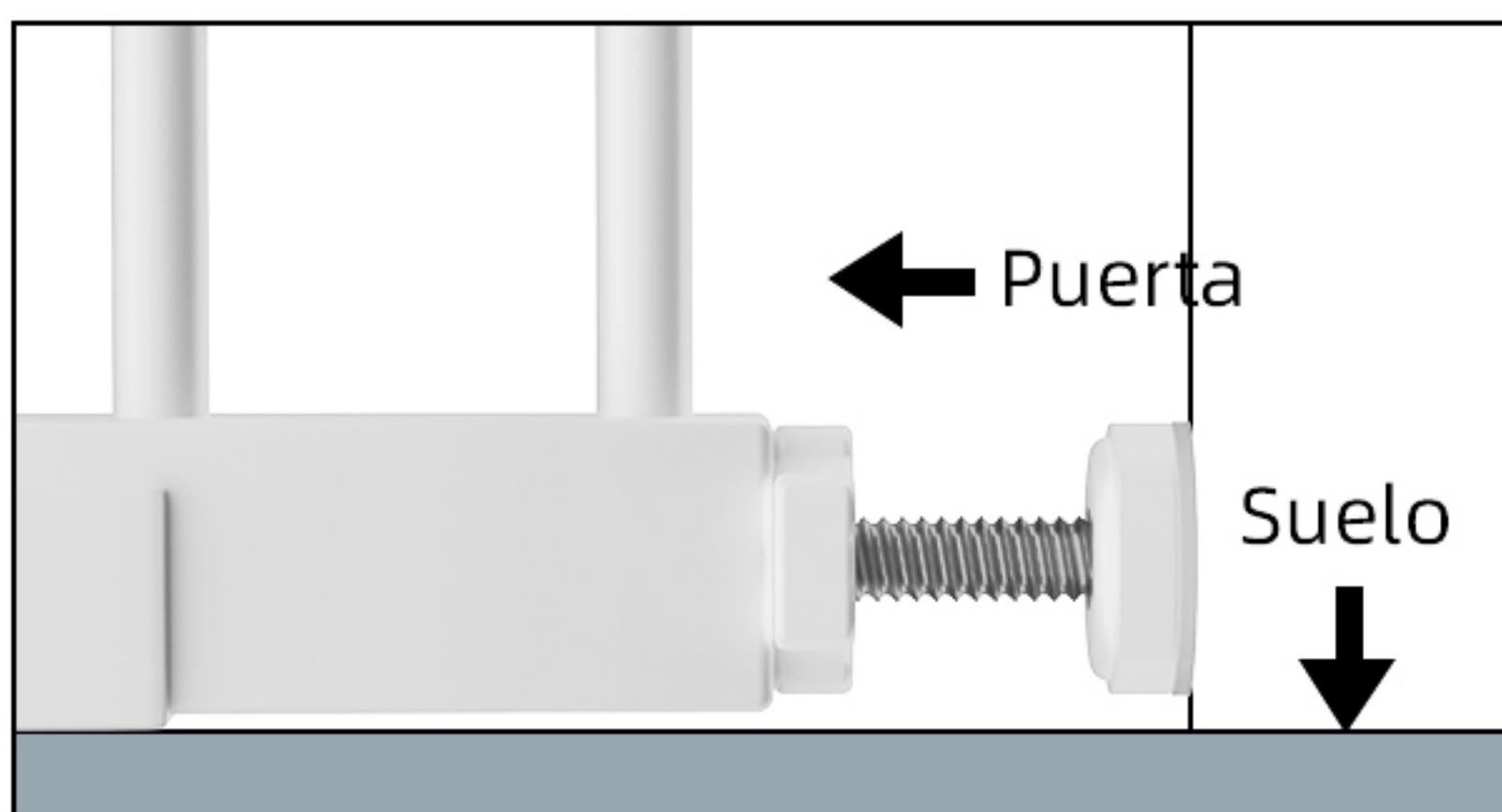

PASO 2.

Ulice la almohadilla adhesiva cuando se realiza la instalación por presión. Quite los papeles protectores de las almohadillas adhesivas, y péguelas en las copas de pared. Luego cubre las copas de pared en los pernos.

SUGERENCIA: Puede omitir este paso si no tiene preocupaciones sobre los daños de la pared.

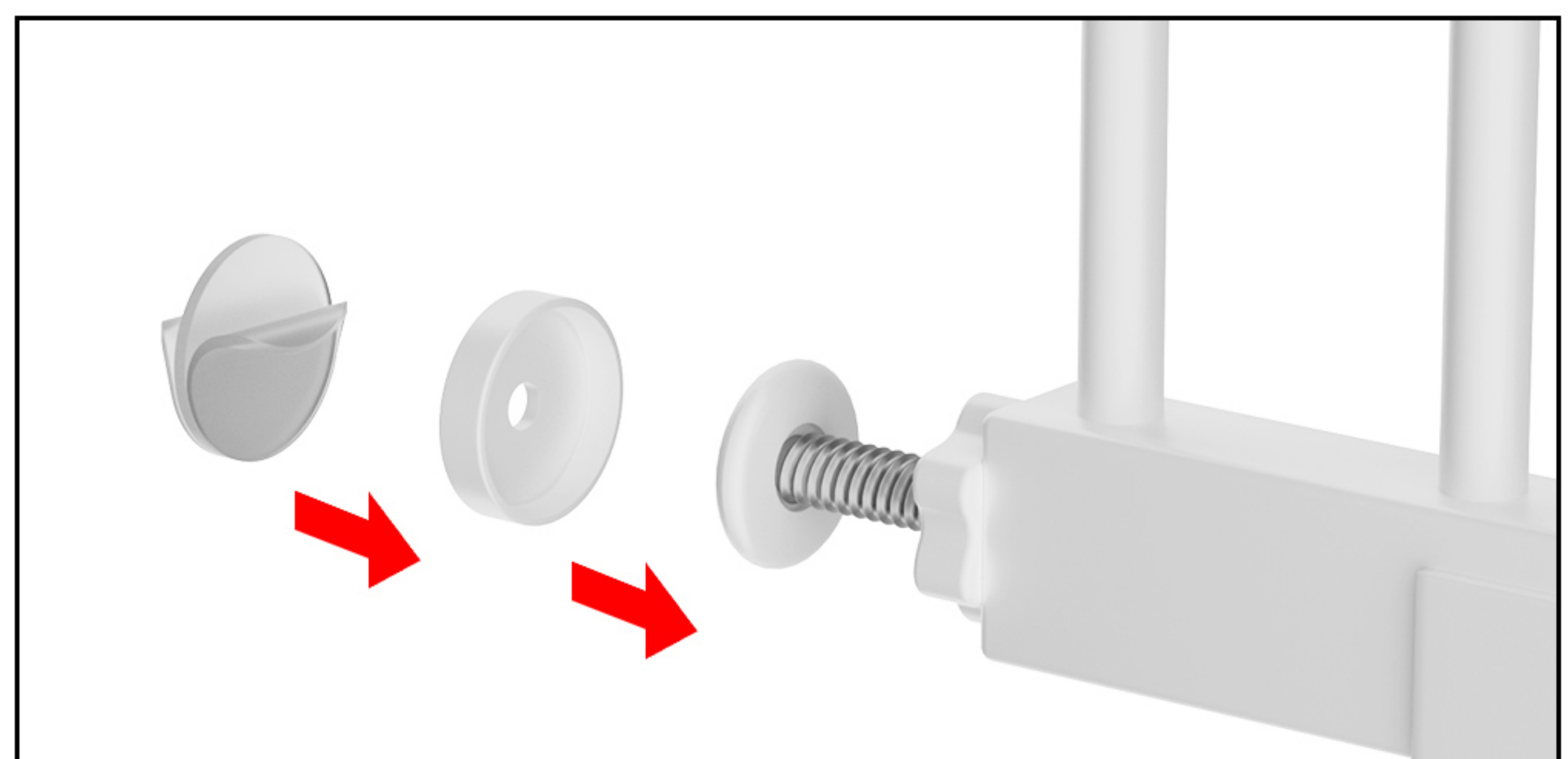

PASO 3.

Taladre orificios las 4 posiciones marcadas, luego coloque el anclaje para pared seca (g), el tornillo (f) y la copa de pared (d).

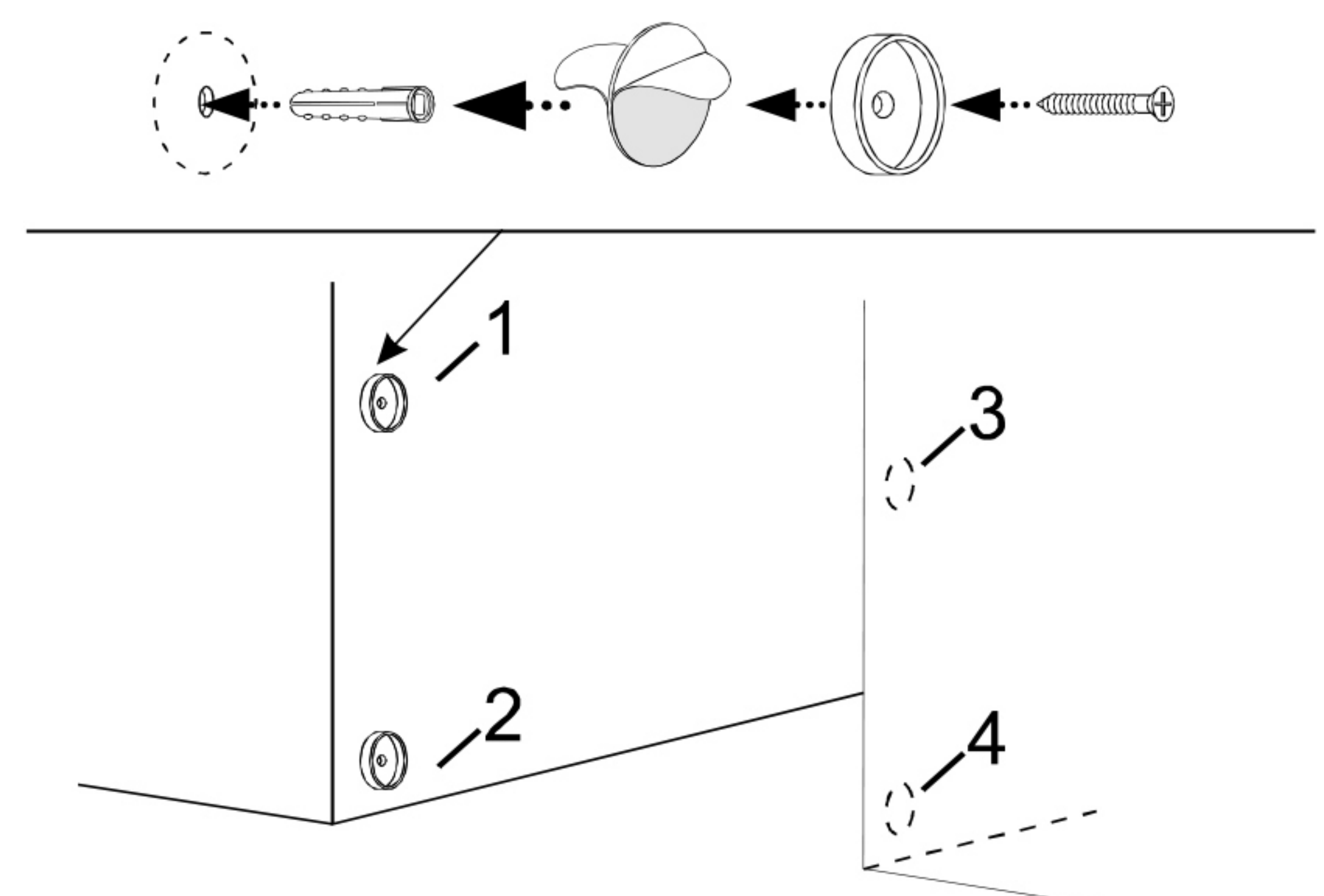
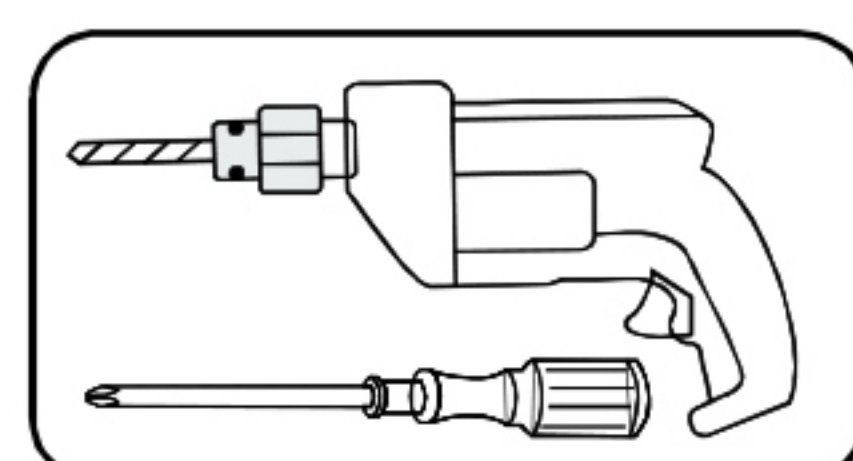
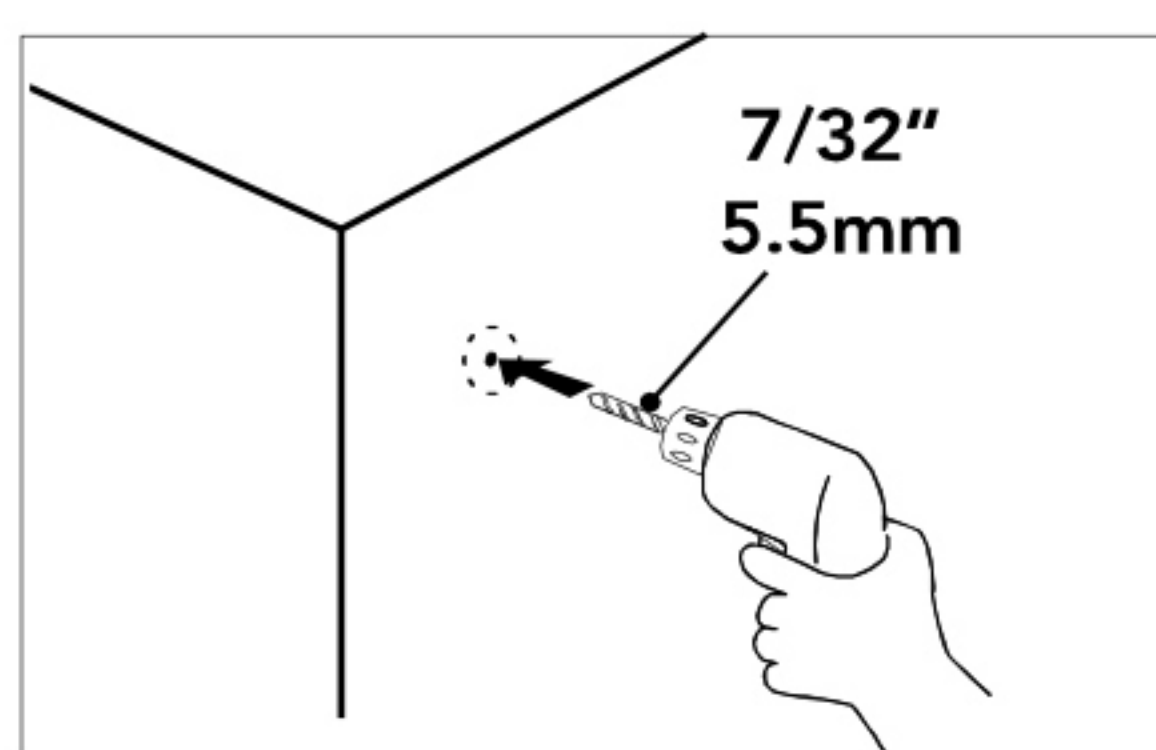

Este producto no requiere herramientas de montaje.

PASO 4.

PASO 6. Apriete la parte superior con las perillas de tensión girándolas en el sentido horario al mismo tiempo.

Nota: Asegúrese de que la parte inferior de la puerta permanezca completamente apoyada sobre el piso.

Luego, apriete la parte inferior con las perillas de tensión en la parte superior al mismo tiempo girándolas en el sentido horario.

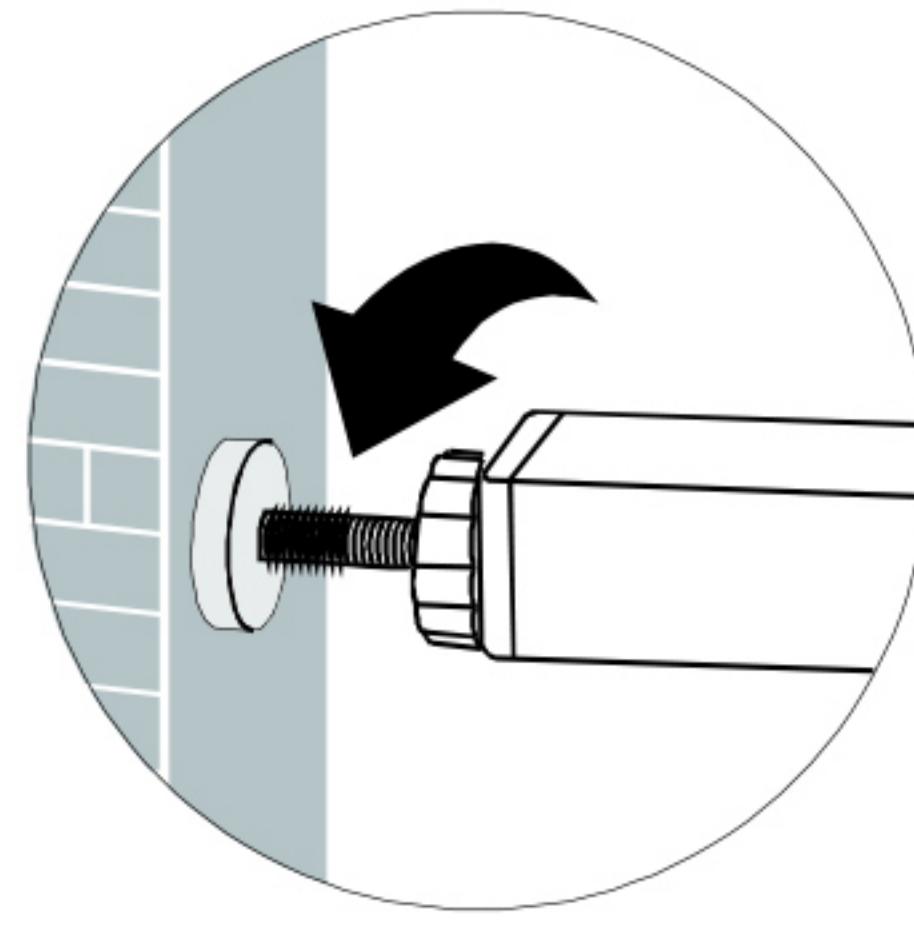

Apriete los 4 pernos

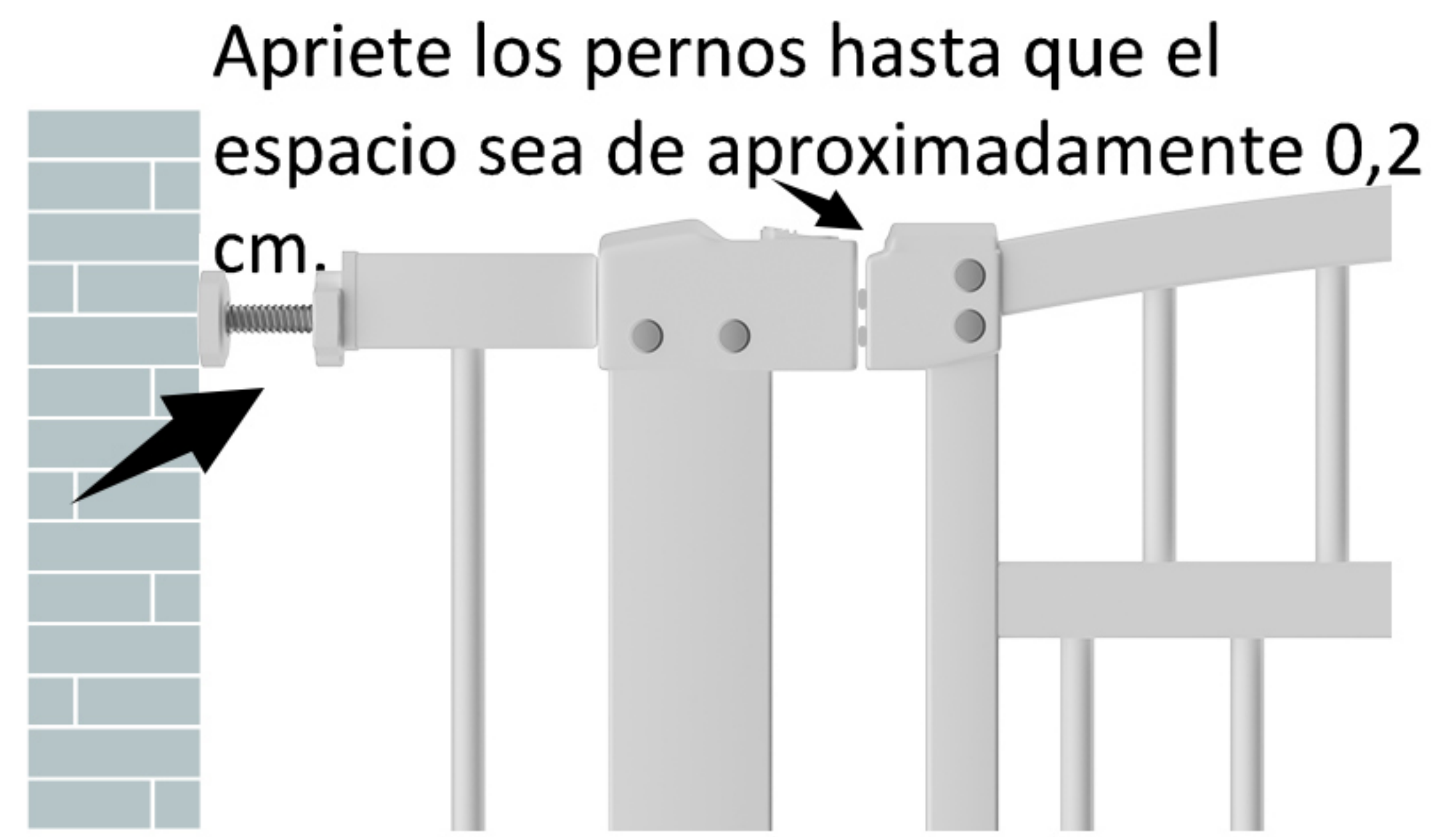

PASO 5.

Corte la cinta y inspeccione la puerta:

1. Empuje la puerta para comprobar su estabilidad.

2. Abra y cierre la puerta de paso.

Método de abrir la puerta de paso:

Tire del botón hacia la derecha, luego levante el panel de la puerta HACIA ARRIBA para abrirla.

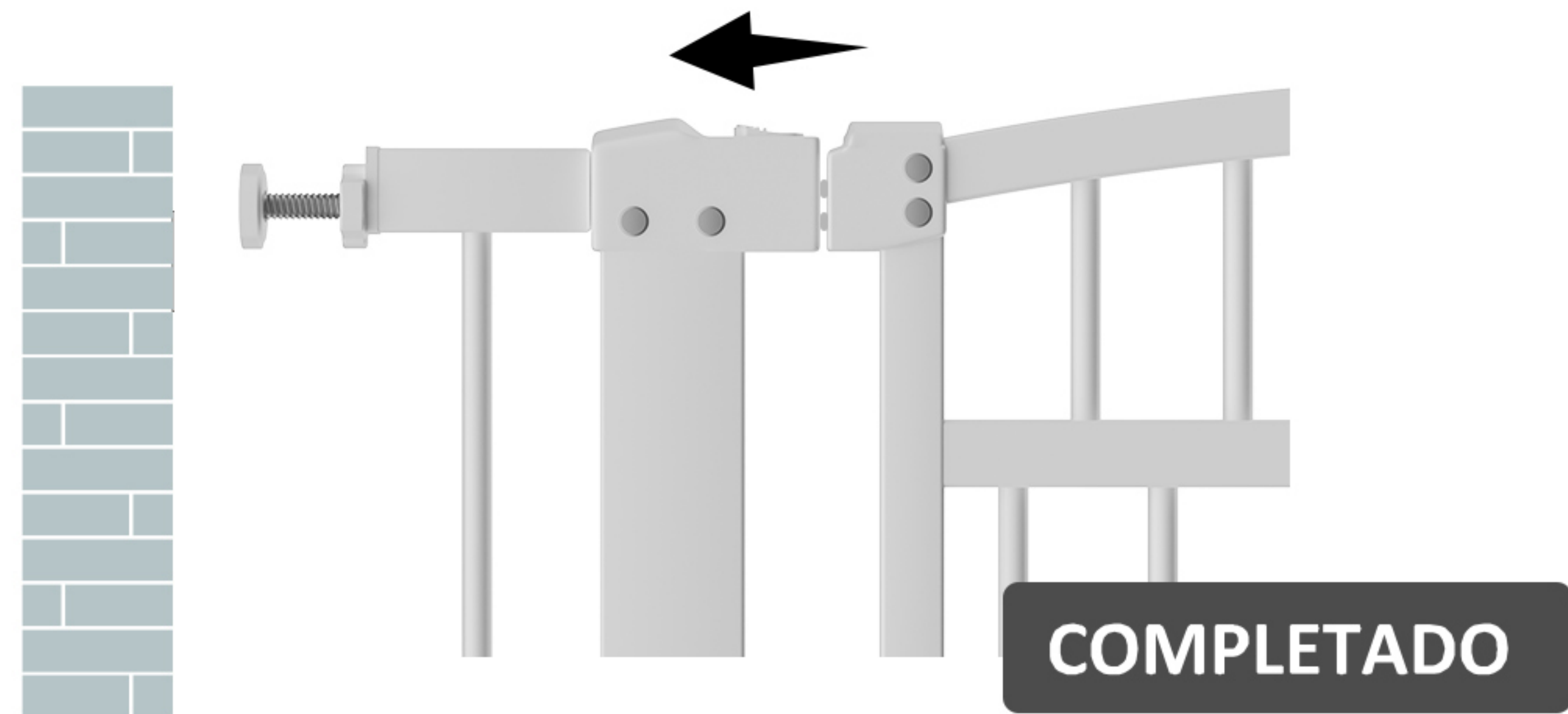

SOLUCIÓN DE PROBLEMAS

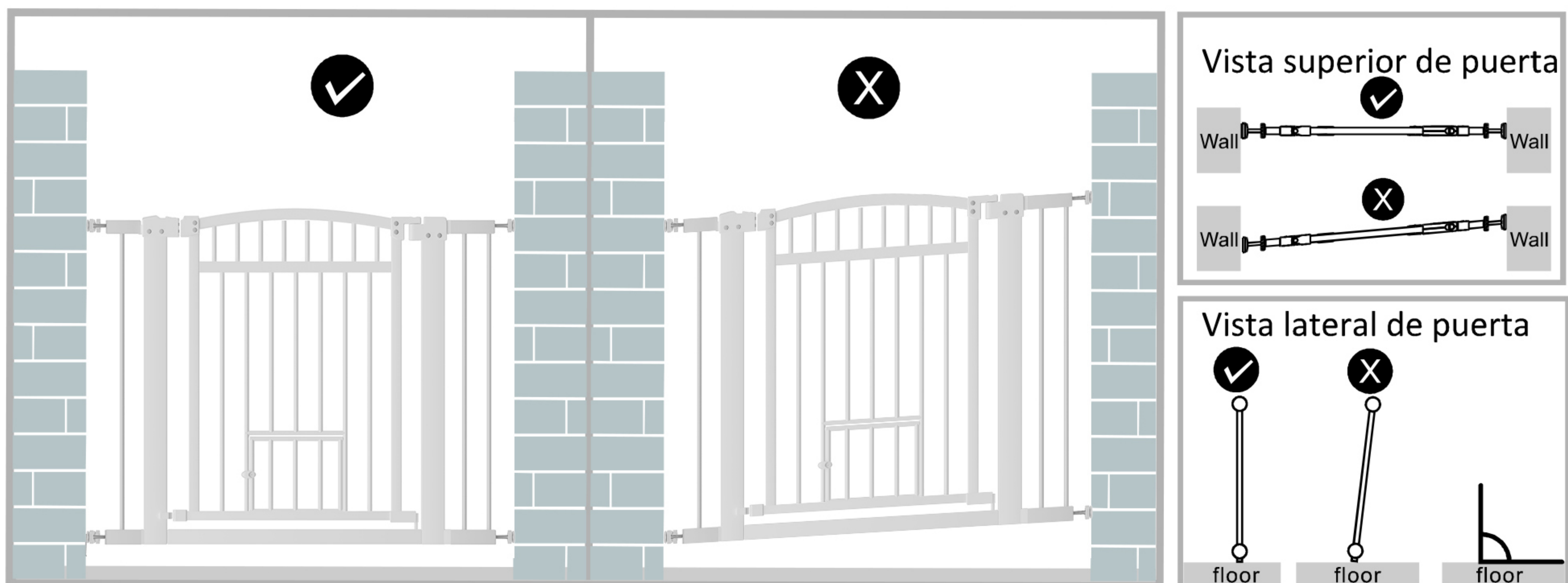

! ADVERTENCIA

- Para evitar lesiones graves o la muerte, instale la puerta o el gabinete de forma segura y utilícelo de acuerdo con las instrucciones del fabricante.
- Utilice el producto con el mecanismo de bloqueo seguramente enganchado. No utilice la puerta si falta alguna pieza o está dañada.
- SIEMPRE instale y use las puertas como se indica con todas las piezas ensambladas.
- Periódicamente revise todos los sujetadores para asegurarse de que estén apretados y seguros.
- El ensamblaje debe realizarse por adulto.
- Las superficies a las que se fijará la puerta deben ser adecuadas para el propósito y deben ser estructuralmente sólidas.
- Sólo para uso en interiores, no debe exponerse a ambientes exteriores.
- Instale esta puerta lejos de calentadores y otras fuentes de calor.



Produkt & Teile

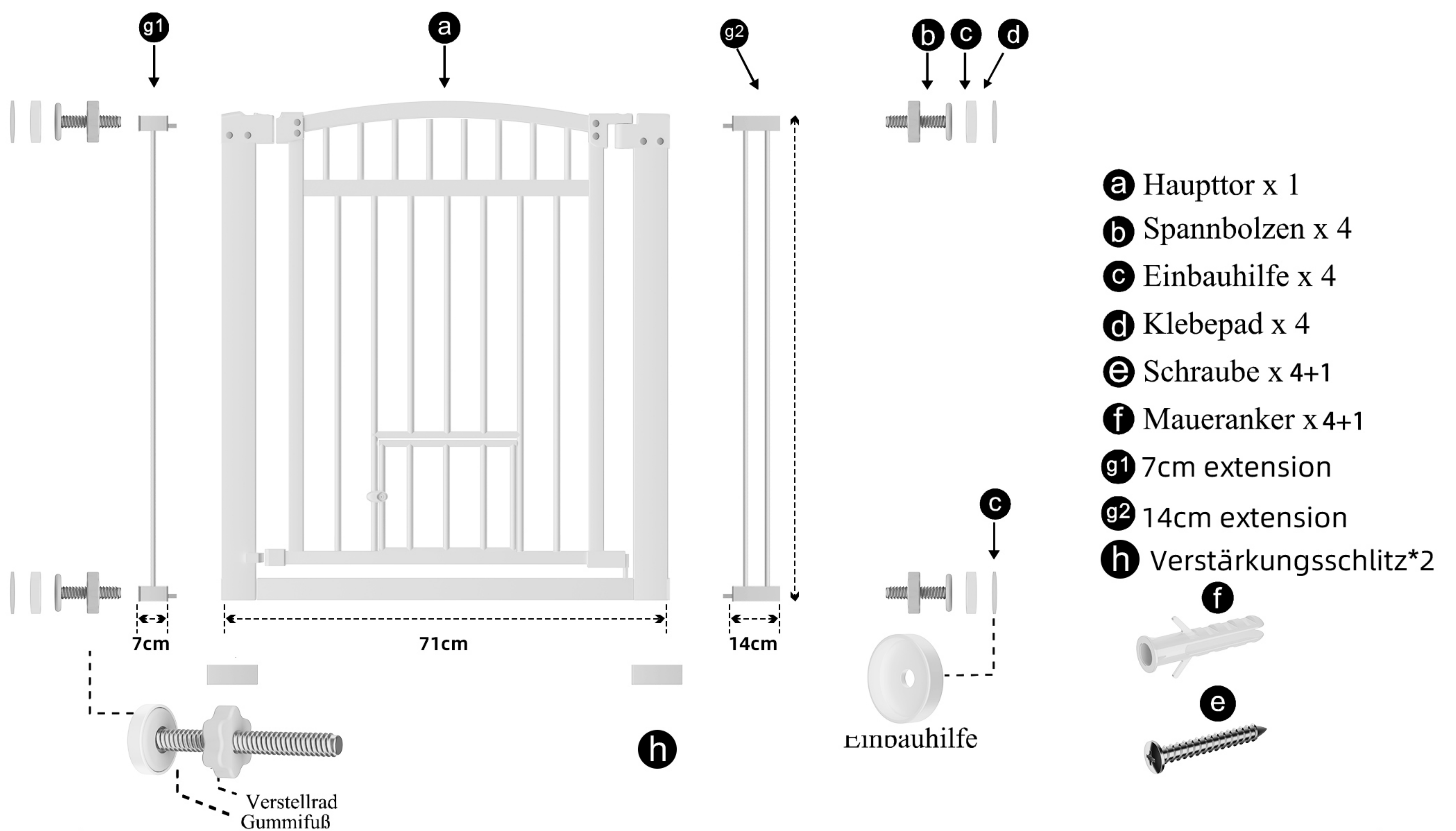

Das Bild dient nur als Referenz, bitte legen Sie das Objekt als Standard an.



WARNUNG: Dieses Paket enthält Kleinteile und scharfe Spitzen in einem unmontierten Zustand. Außerhalb der Reichweite von Kindern aufbewahren. Montage durch einen Erwachsenen erforderlich.

Warnung:
Um die Installation zu erleichtern, schneiden Sie den Riemen nicht ab, bevor die Installation abgeschlossen ist!
Der Türspalt ist KEIN Defekt!
Er wird nach der Installation auf 0,2 cm verkürzt.

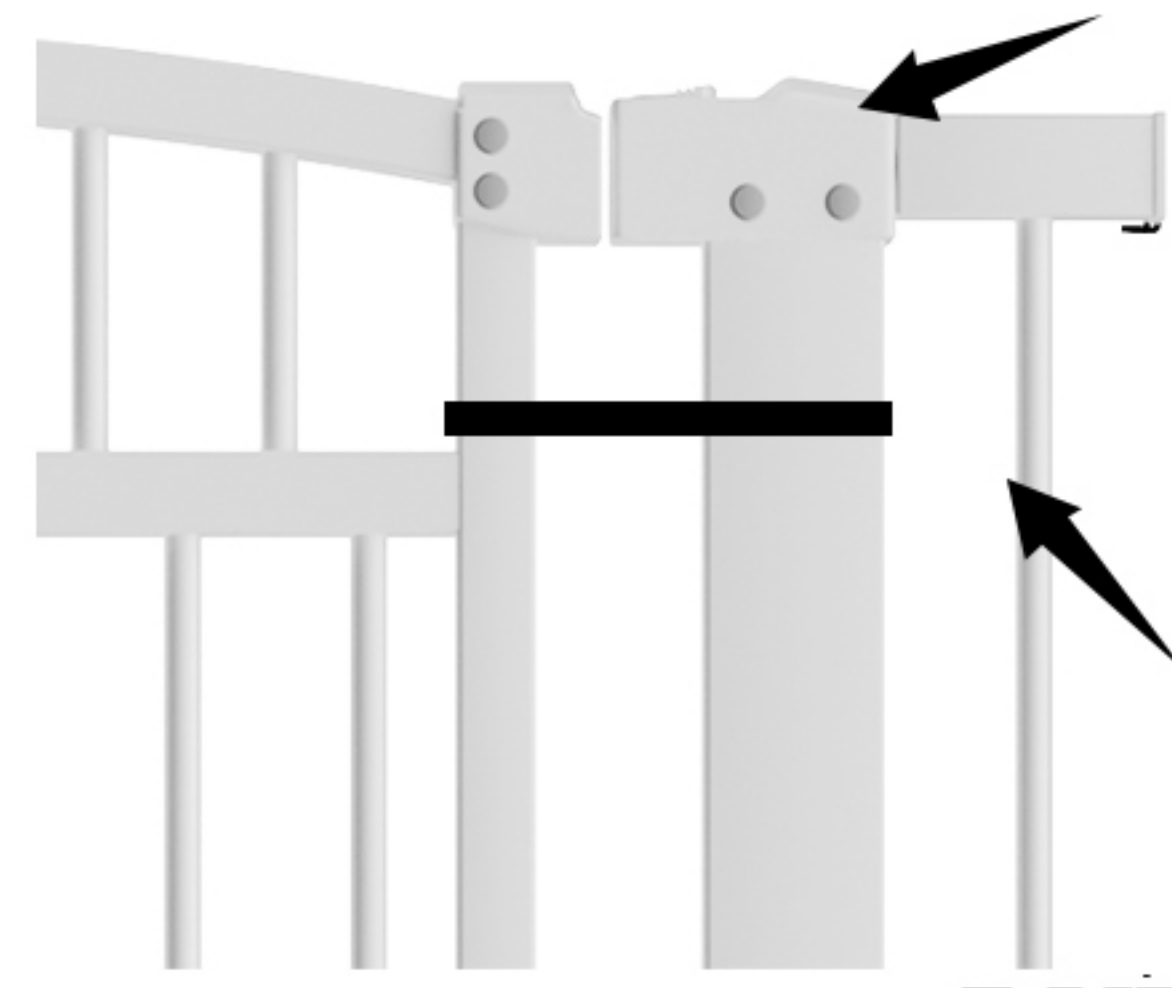

Der Türspalt ist KEIN Defekt!
Nach der Installation wird er auf 0,2 cm verkürzt sein



VERMEIDEN SIE DEN RIEMEN NICHT DURCH Vor Abschluss der Installation

Hinweis: Schrauben Sie bei Verwendung des Tores auf einer Treppe die Einbauhilfen ein



Unterseite der Treppe

Wird das Tor am unteren Ende der Treppe verwendet, um zu verhindern, dass das Kind die Treppe hochklettert, muss es auf der untersten Stufe angebracht werden.

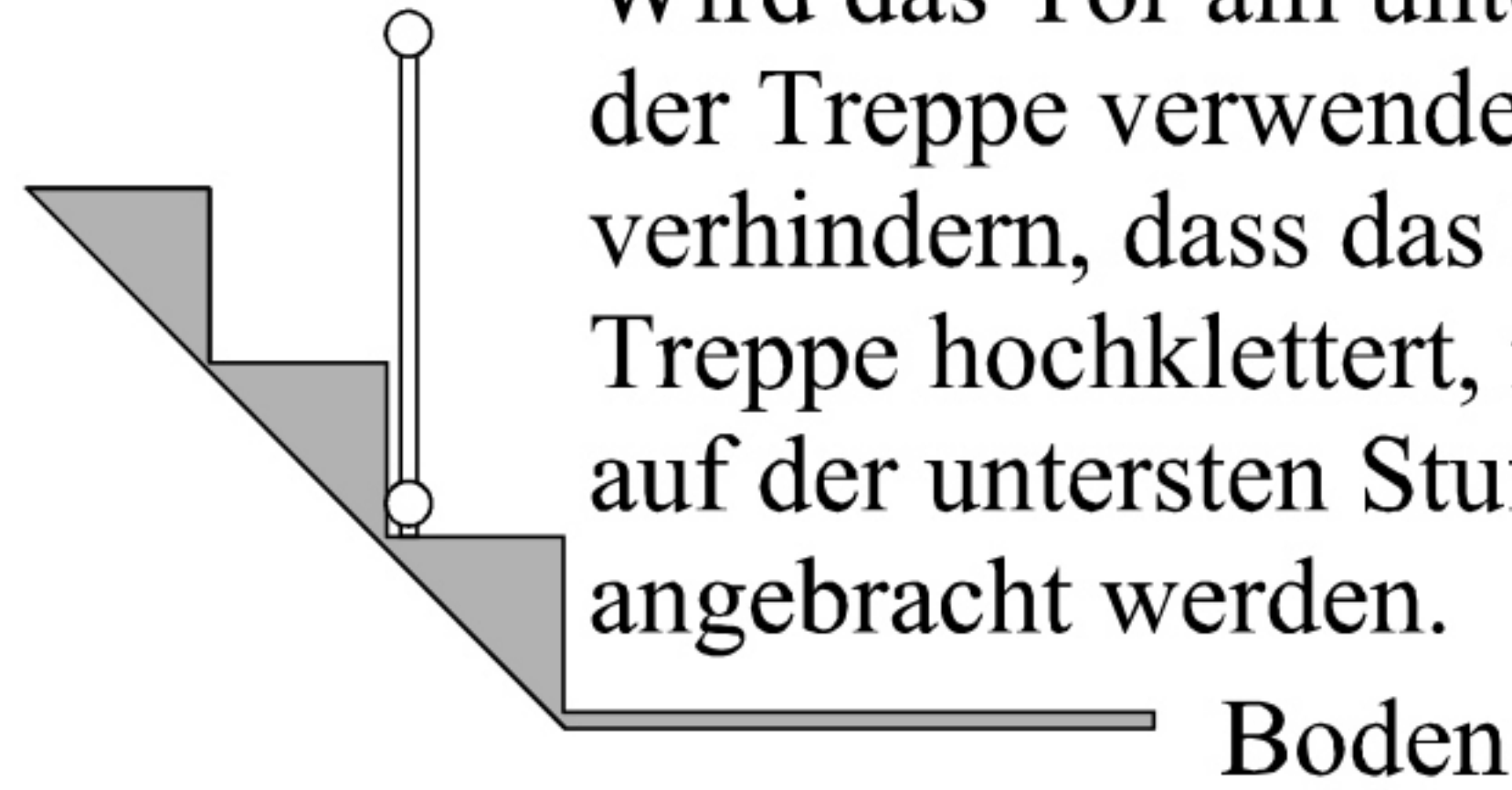

Oberseite der Treppe

Wenn das Tor am oberen Ende der Treppe verwendet wird, um zu verhindern, dass das Kind die Treppe unterhalb der obersten Stufe hinunterfällt

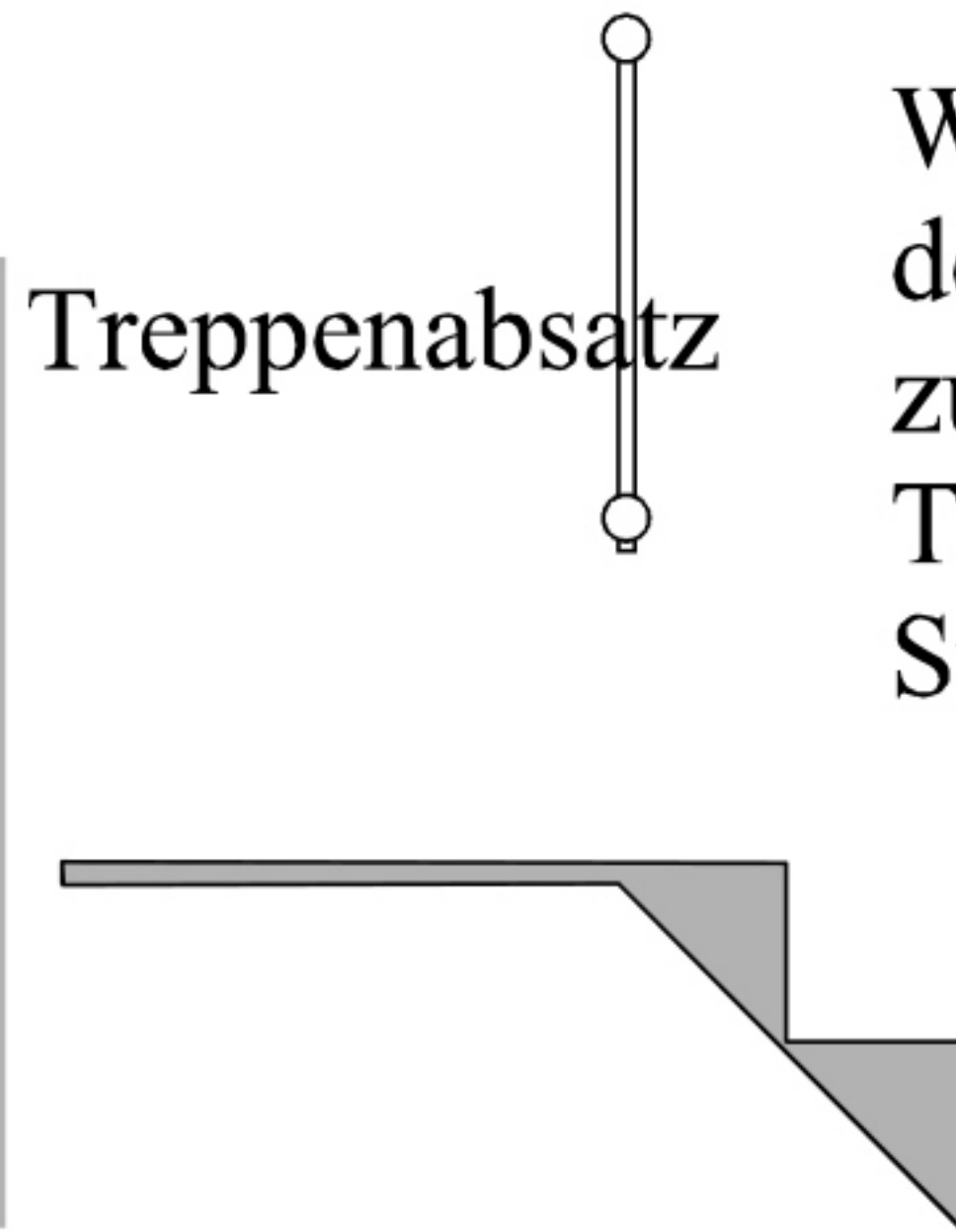

SCHRITT 1.

Montieren Sie das Tor vor und suchen Sie vier Punkte für die Lochbohrung. Halten Sie die Einbauhilfe in Position und markieren Sie die Mitte mit einem Bleistift.

BITTE BEACHTEN: Das Tor sollte auf dem Boden aufliegen. Lassen Sie KEINEN Spalt von mehr als 0,5 cm zwischen dem Tor und dem Boden.

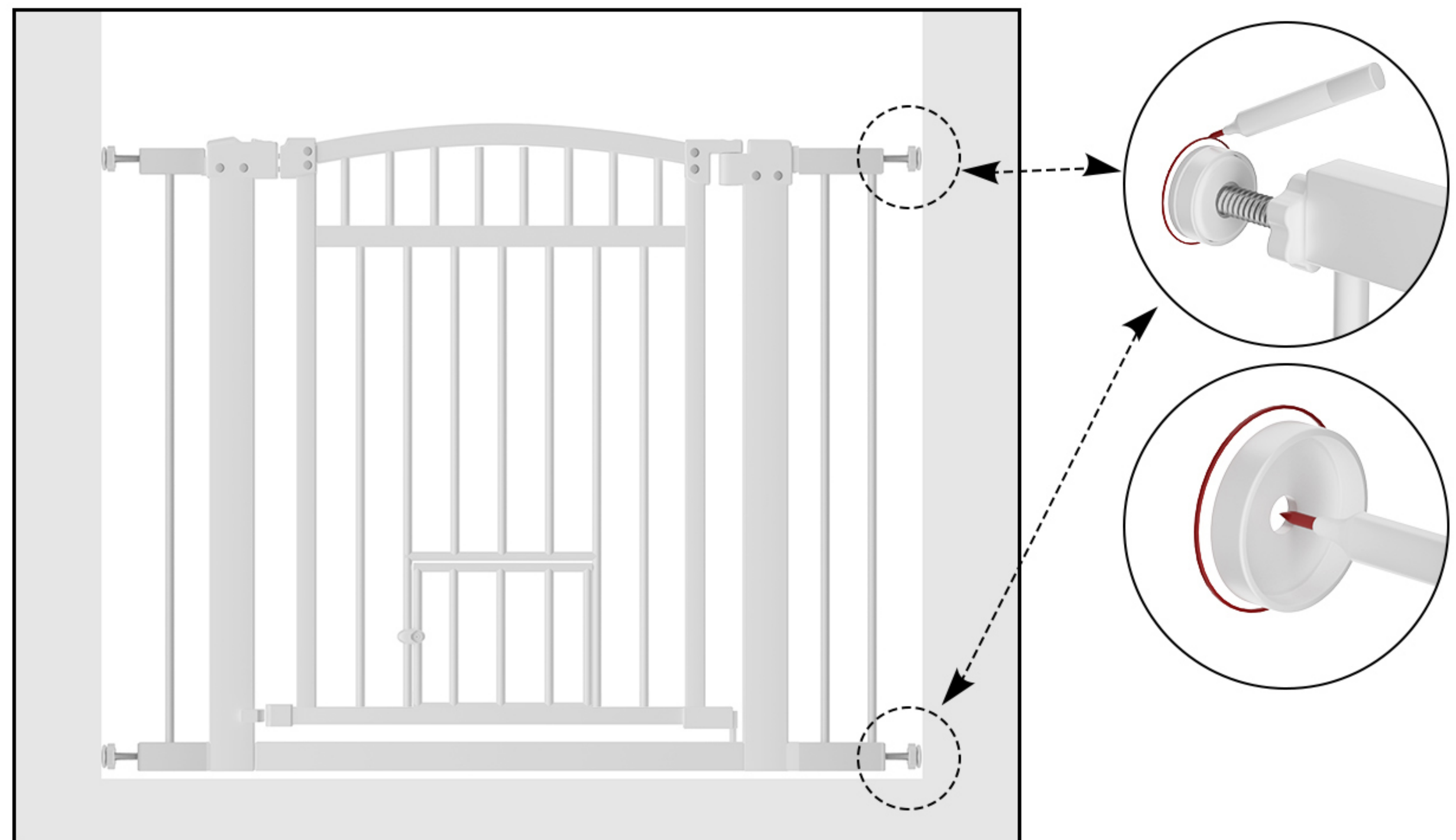
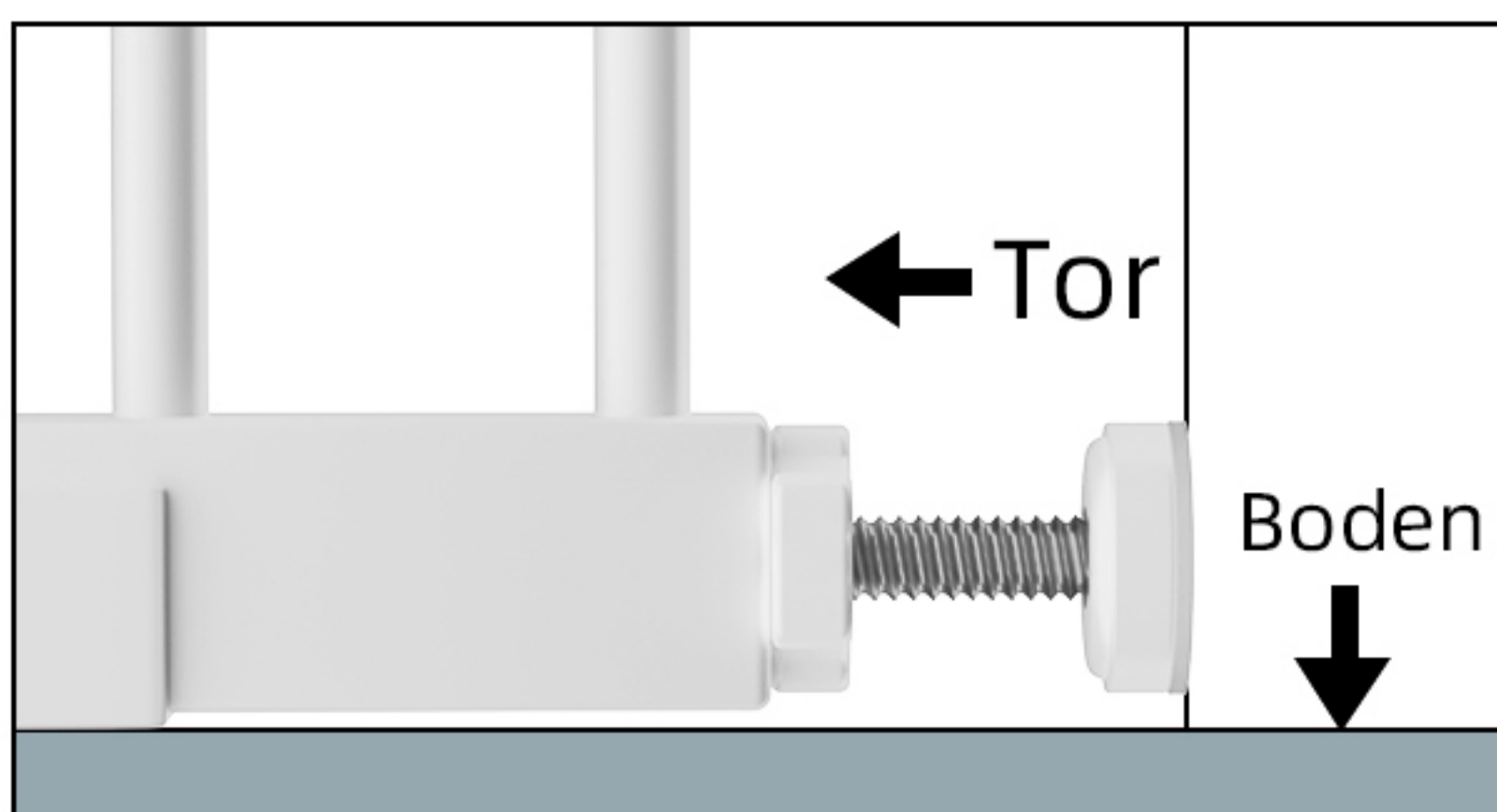

SCHRITT 2.

Klebepad bei druckmontierter Installation. Entfernen Sie zwei Seiten des Klebe pads, kleben Sie 4 Pads auf 4 Einbauhilfen. Die Einbauhilfen decken dann die Bolzen ab.
TIPP: Wenn Sie nicht befürchten müssen, die Wände zu beschädigen, überspringen Sie diesen Schritt.

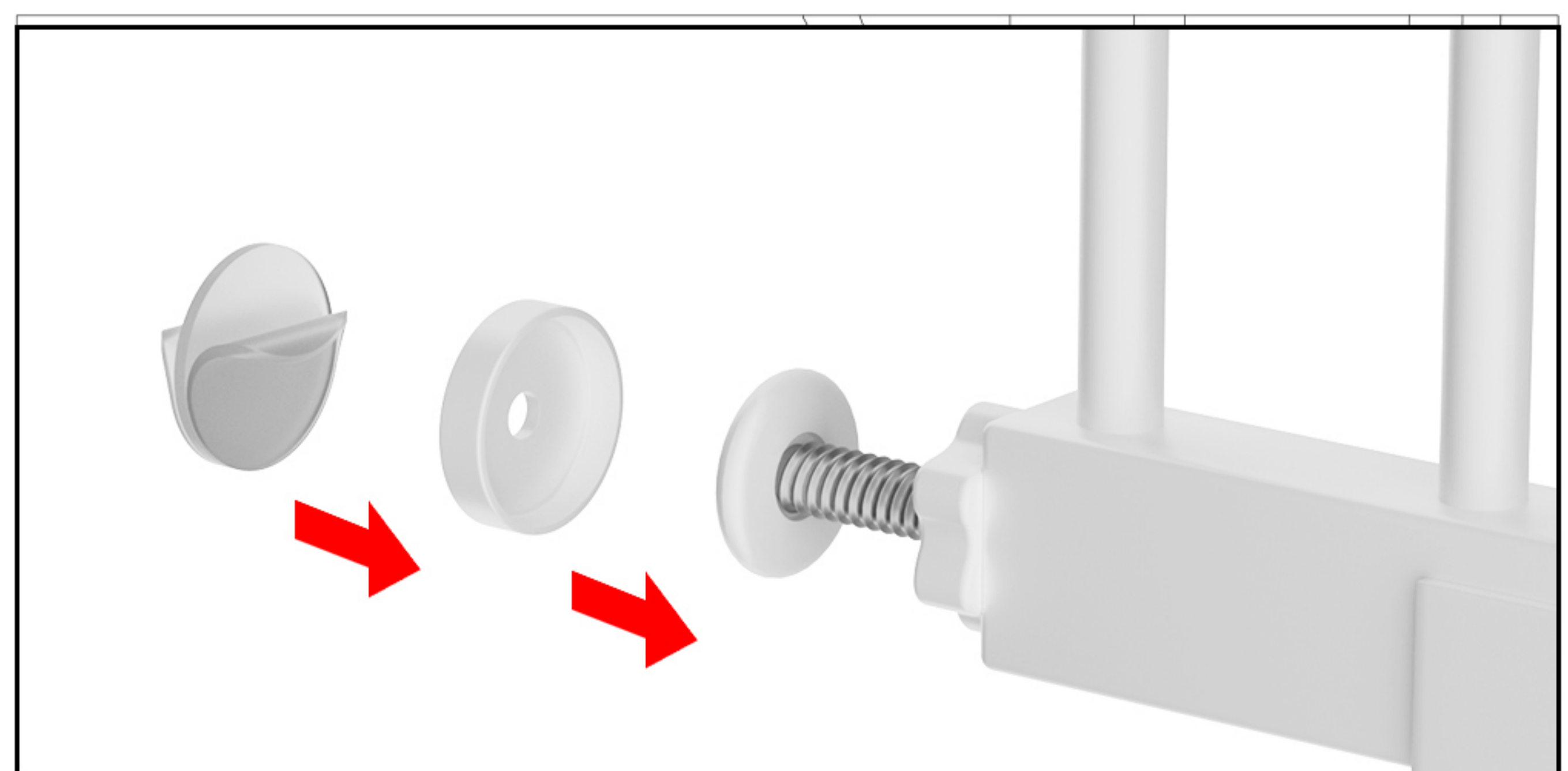

SCHRITT 3.

Bohren Sie ein Loch für die 4 markierten Positionen, setzen Sie dann den Maueranker (g) ein und verwenden Sie die Schraube (f) und die Einbauhilfen (d)

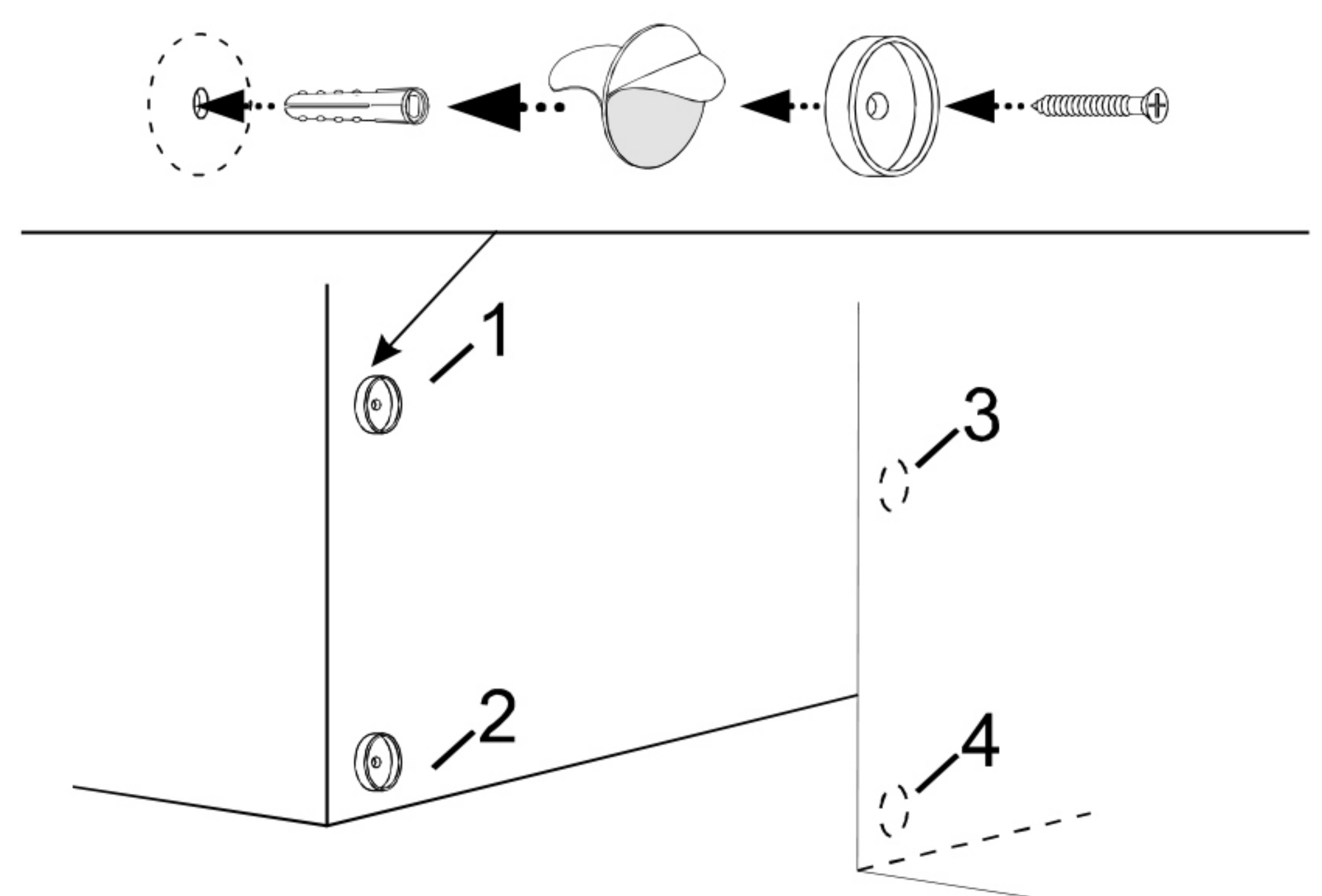
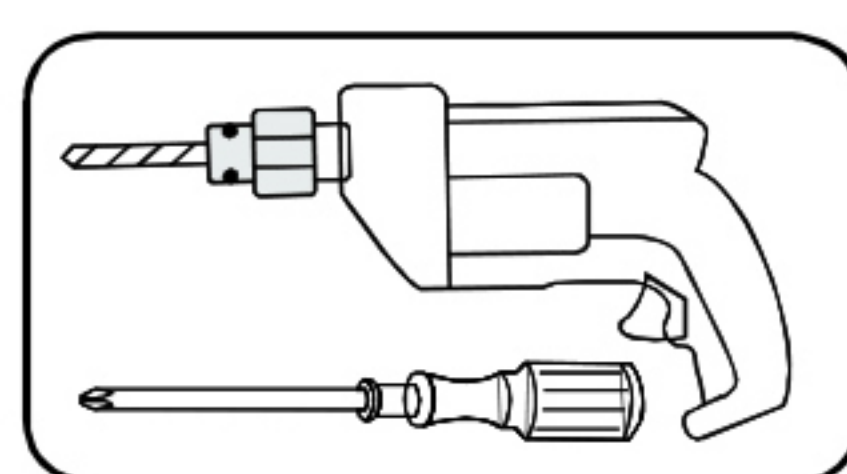
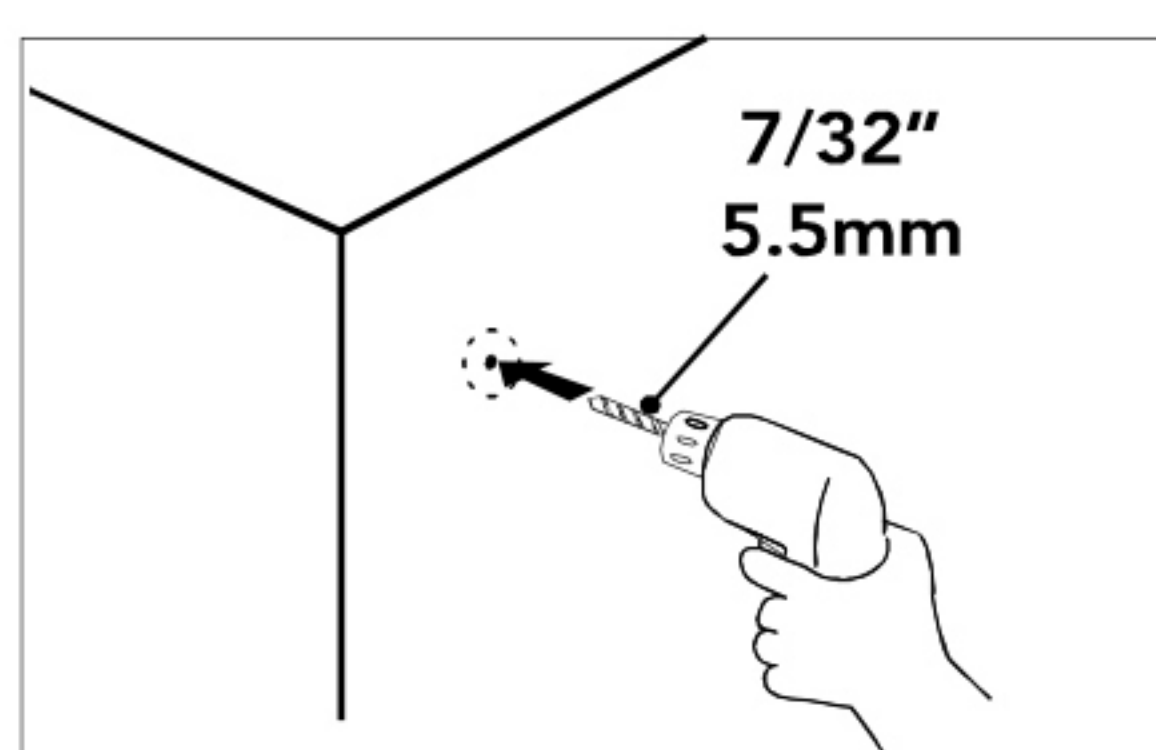

Das Produkt enthält kein Installationswerkzeug

SCHRITT 4.

SCHRITT 6. Ziehen Sie die Oberseite der Spannknöpfe durch gleichzeitiges Drehen im Uhrzeigersinn fest.
Hinweis: Achten Sie darauf, dass die Unterseite des Torrahmens vollständig flach auf dem Boden liegt.
Ziehen Sie anschließend die unteren der Spannknöpfe oben gleichzeitig durch Drehen im Uhrzeigersinn fest.

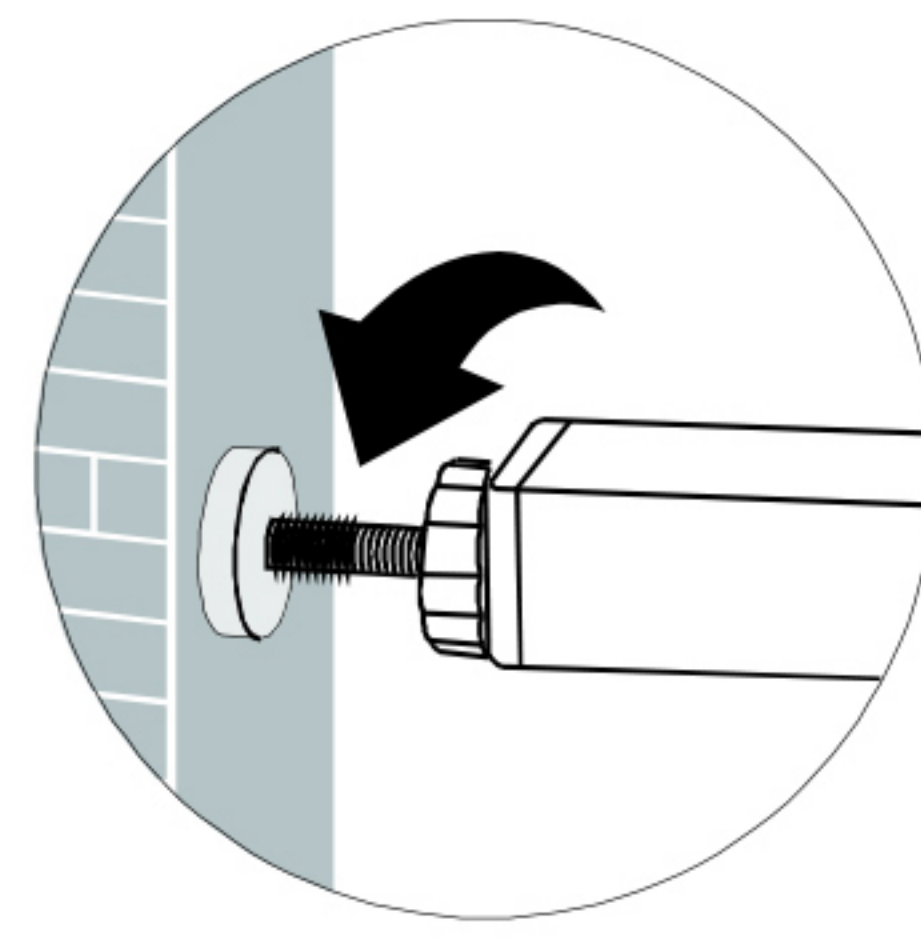

Drehen Sie 4 Bolzen

Drehen Sie die Schrauben, bis der Spalt etwa 0,2 cm beträgt

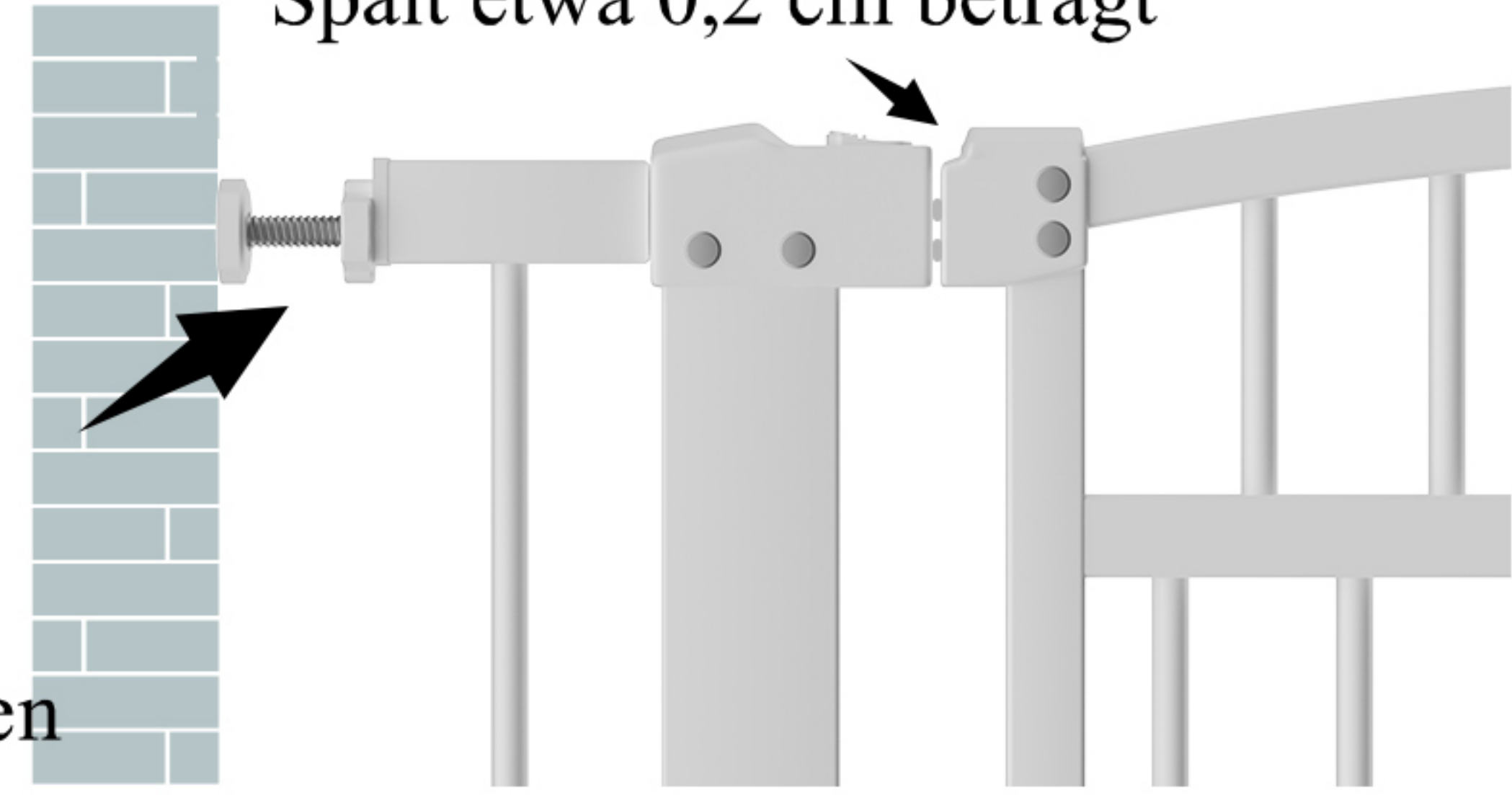

SCHRITT 5.

Schneiden Sie den Riemen ab und testen Sie das Tor:
1. Schieben Sie das Tor, um die Stabilität zu prüfen.
2. Öffnen und schließen Sie das Durchgangstor
Öffnungsmethode:
Ziehen Sie die Taste nach rechts, dann heben Sie die Torblende zum Öffnen nach oben.

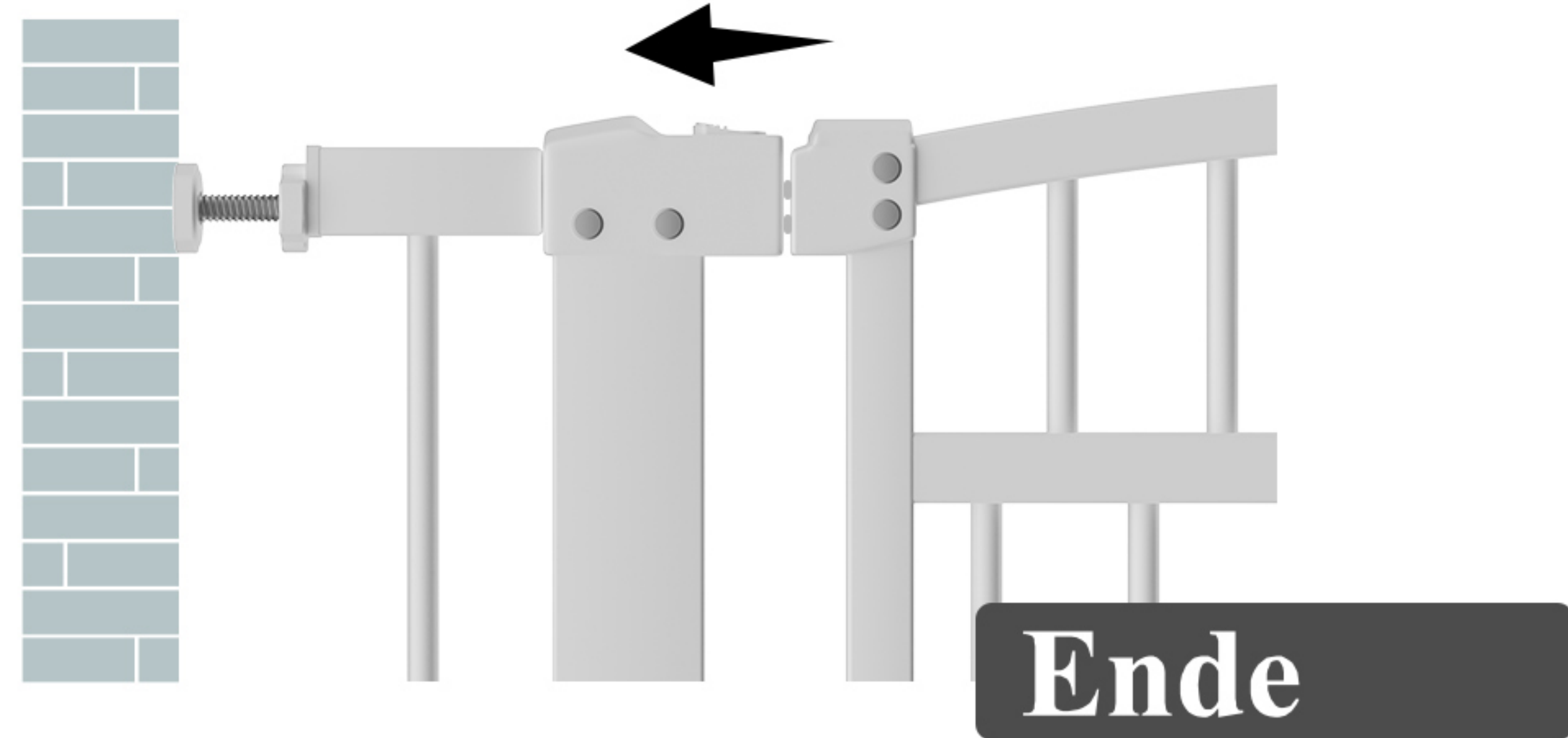

FEHLERBEHEBUNG

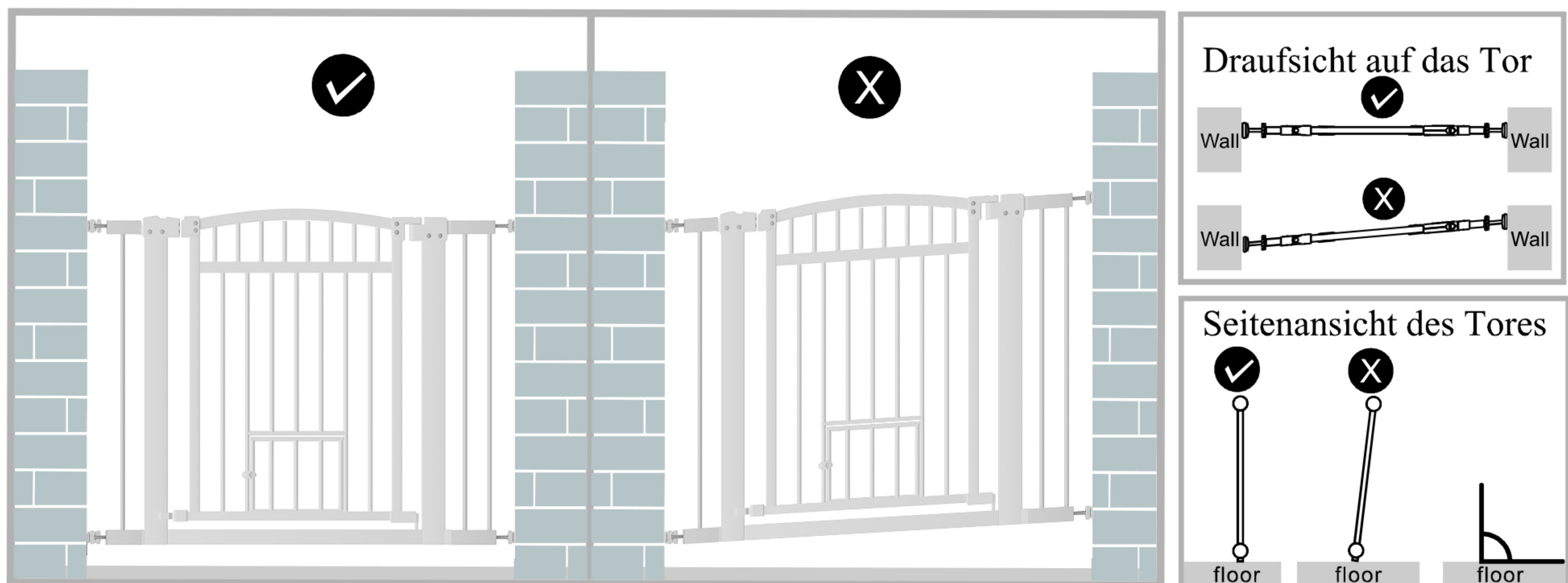

WARNUNG

- Um schwere Verletzungen oder Tod zu vermeiden, installieren Sie das Tor oder die Umrandung sicher und verwenden Sie es gemäß den Anweisungen des Herstellers.
- Verwenden Sie das Tor nur, wenn der Verriegelungsmechanismus sicher eingerastet ist. Verwenden Sie das Tor nicht mehr, wenn Teile fehlen oder beschädigt sind.
- Installieren und verwenden Sie das Tor **IMMER** wie vorgeschrieben und verwenden Sie alle erforderlichen Teile.
- Überprüfen Sie regelmäßig alle Befestigungselemente, um sicherzustellen, dass sie fest und sicher sind.
- Montage durch einen Erwachsenen erforderlich.
- Die Oberflächen, an denen das Tor befestigt werden soll, müssen für den Zweck geeignet und statisch einwandfrei sein.
- Das Tor darf nur in Innenräumen verwendet werden und darf nicht den Elementen im Freien ausgesetzt werden.
- Installieren Sie das Tor nicht in der Nähe von Heizungen oder anderen Wärmequellen.



Prodotto & Parti

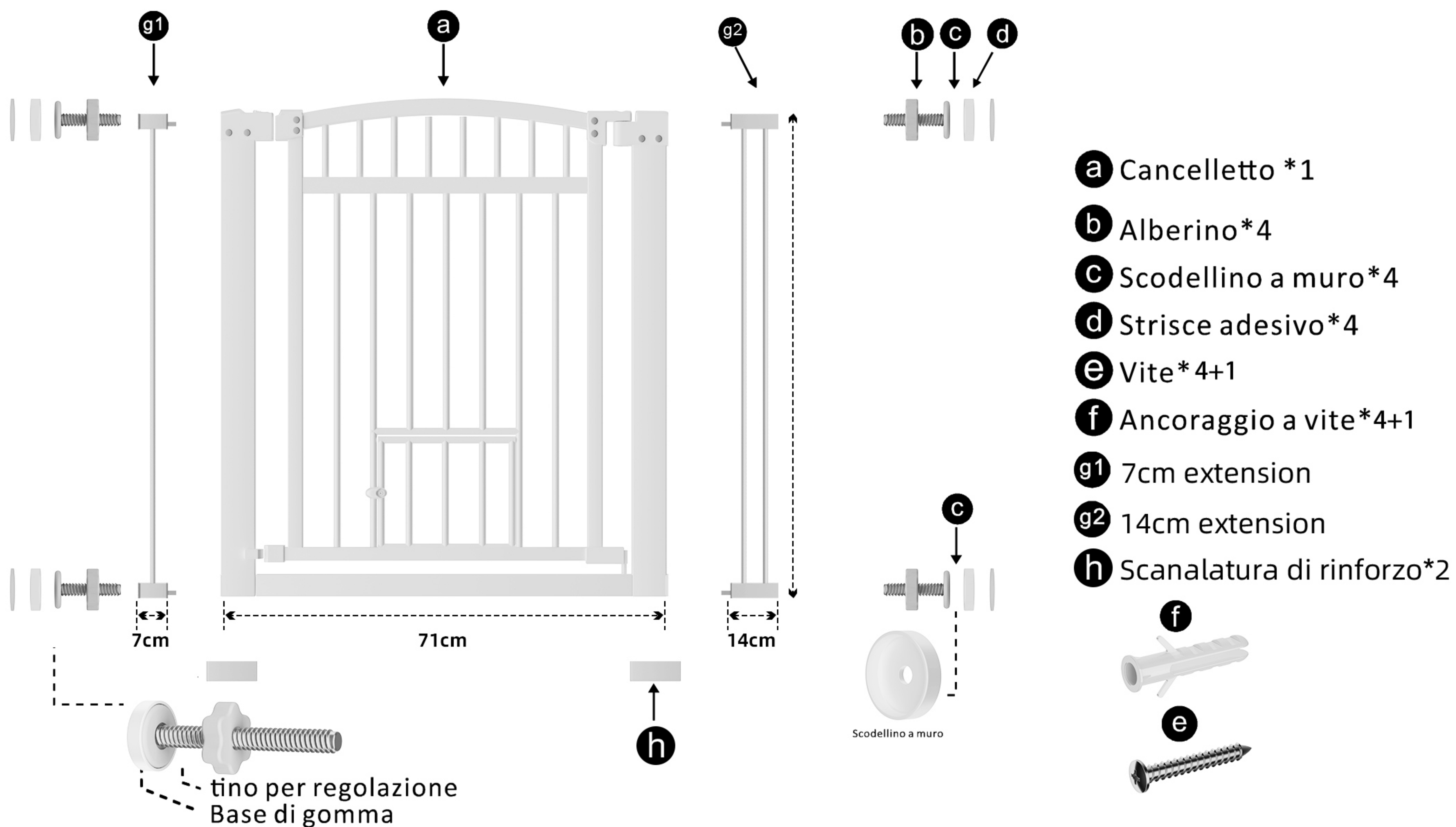

L'immagine è solo per riferimento, si prega di rendere l'oggetto come standard.



AVVERTENZA: Questa confezione contiene piccole parti e punte acuminate quando sia in uno stato non assemblato. Tenere fuori dalla portata dei bambini. È richiesto un adulto per il montaggio.

Avvertenza:

Per facilitare l'installazione, non tagliare la cintura prima che l'installazione sia completata!

L'apertura della porta NON è un difetto! Sarà accorciato a 0,2 cm dopo l'installazione.

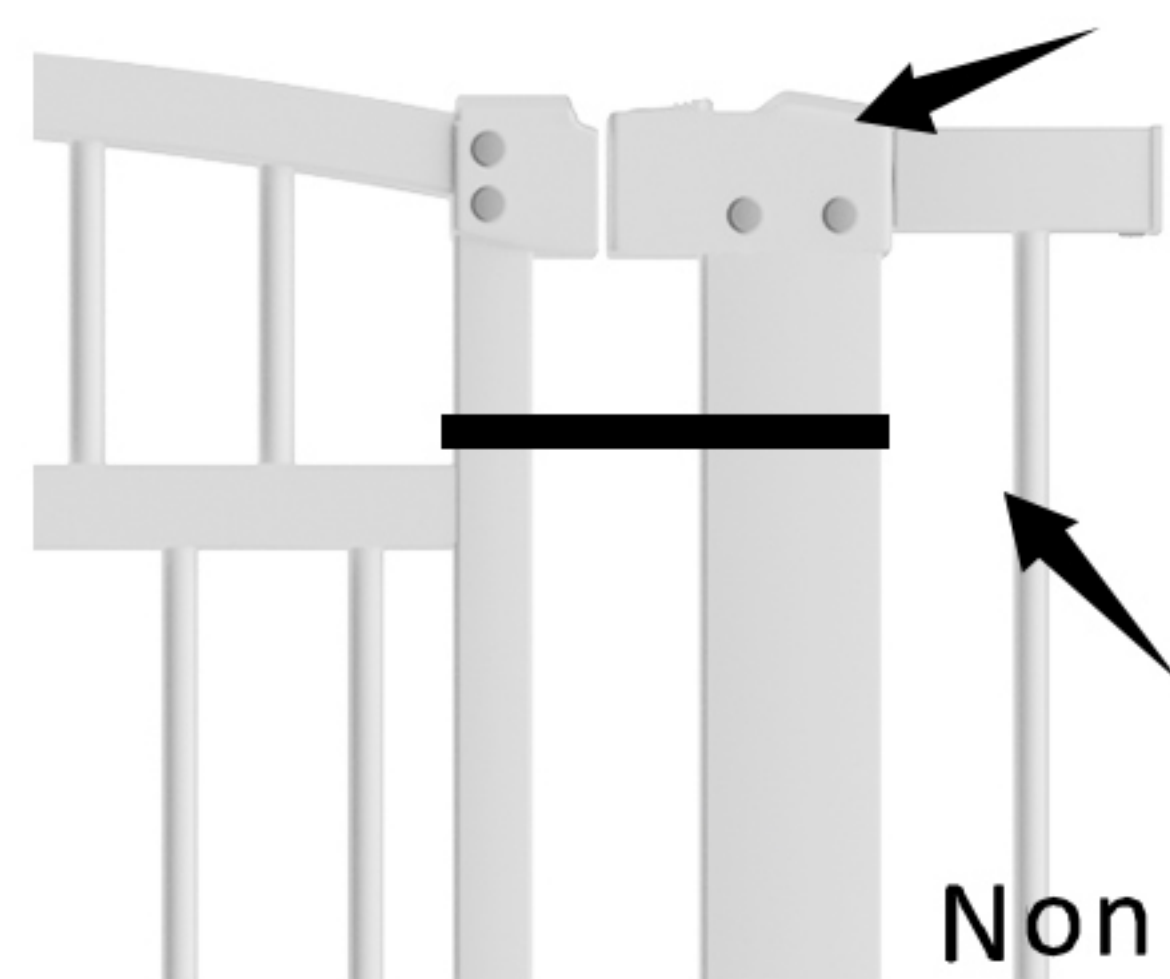

L'apertura della porta NON è un difetto! Sarà accorciato a 0,2 cm dopo l'installazione.



Non tagliare la cintura prima che l'installazione sia completata!

Attenzione: Viti vengono usate nelle scodellini a muro quando si utilizza il cancelletto sulle scale.

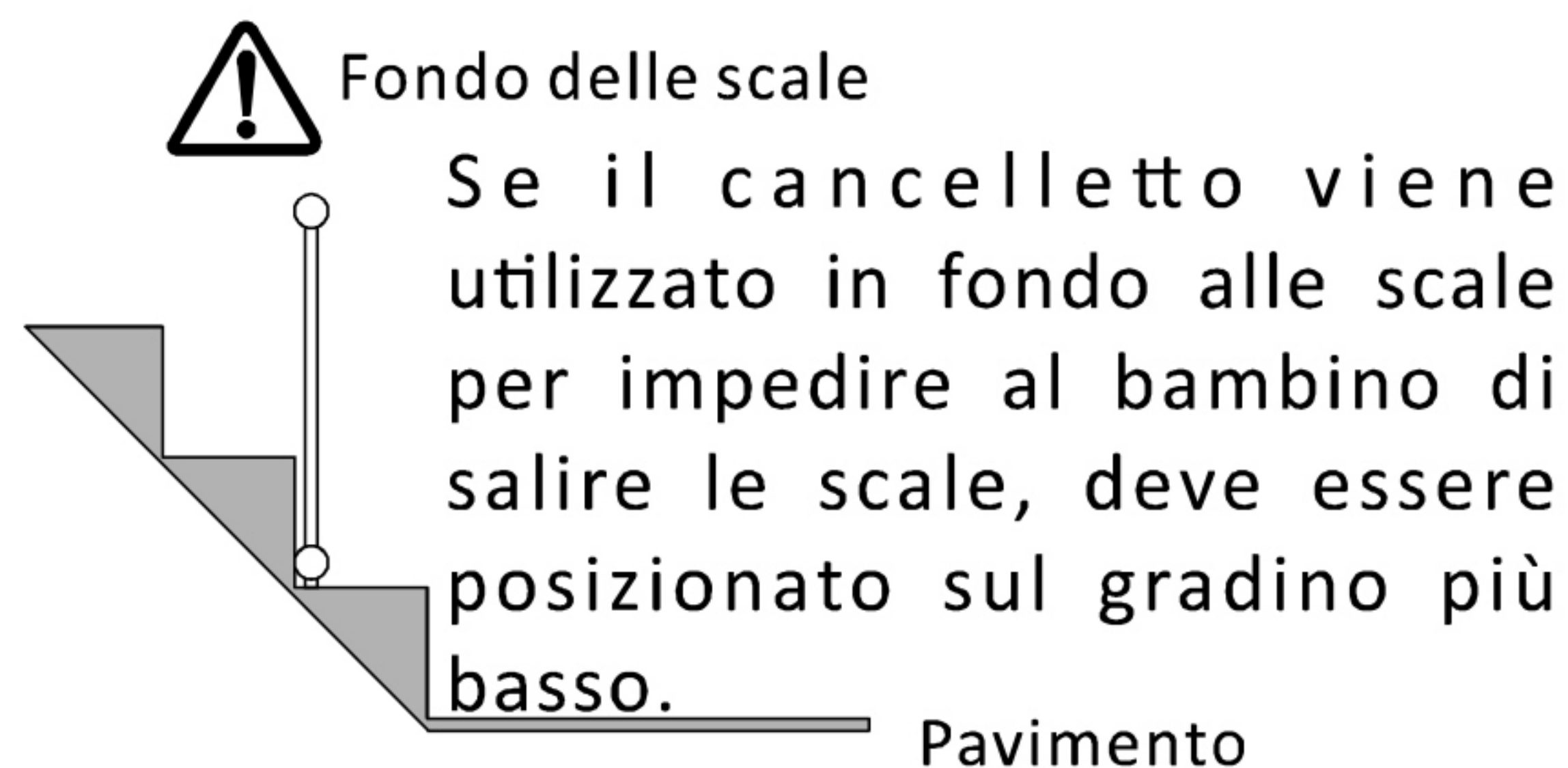

Pavimento

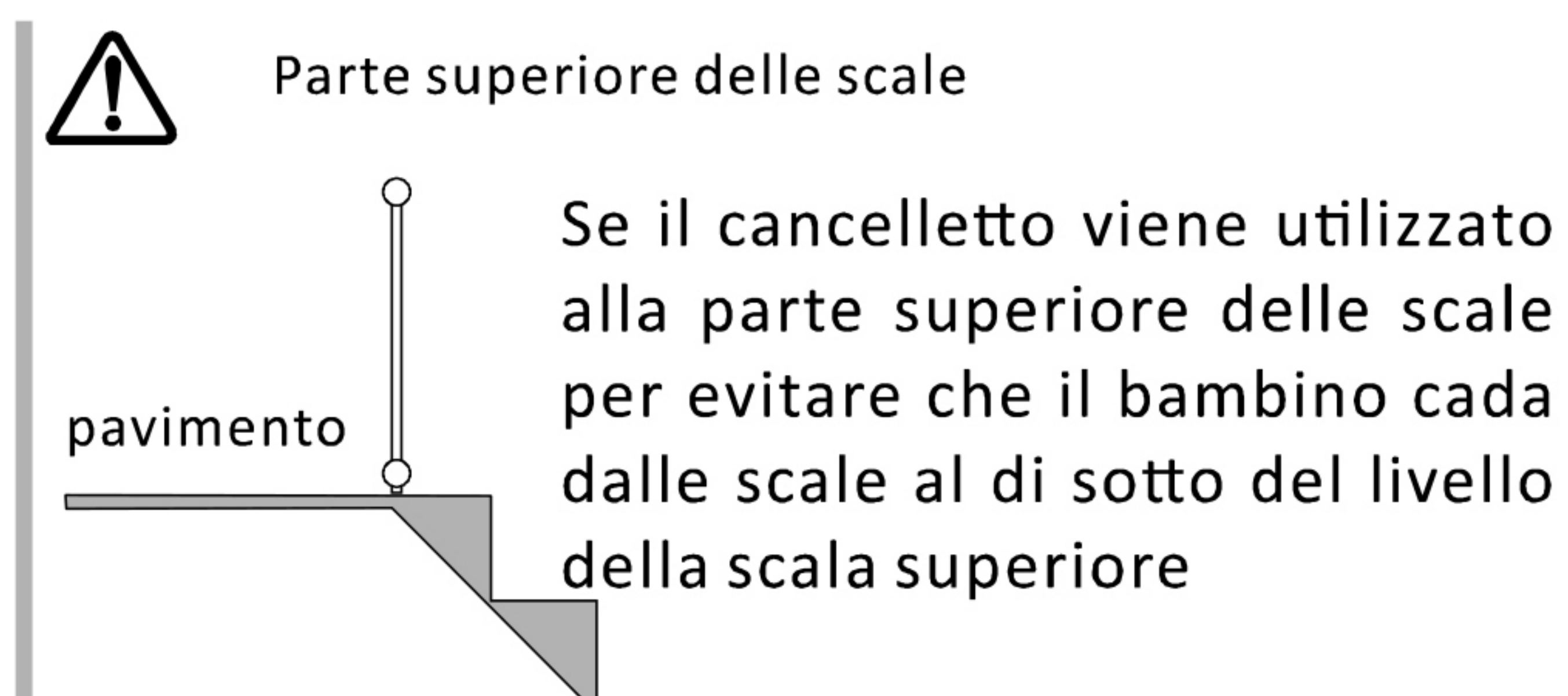

pavimento

Fase 1.

Premontare il cancelletto, e individuare quattro punti per la foratura. Tieni la scodellina da parete in posizione e segna il centro con una matita.

NOTA: Il cancelletto deve essere appoggiato a pavimento. NON lasciare uno spazio superiore a 0,5 cm tra il cancelletto e il pavimento.

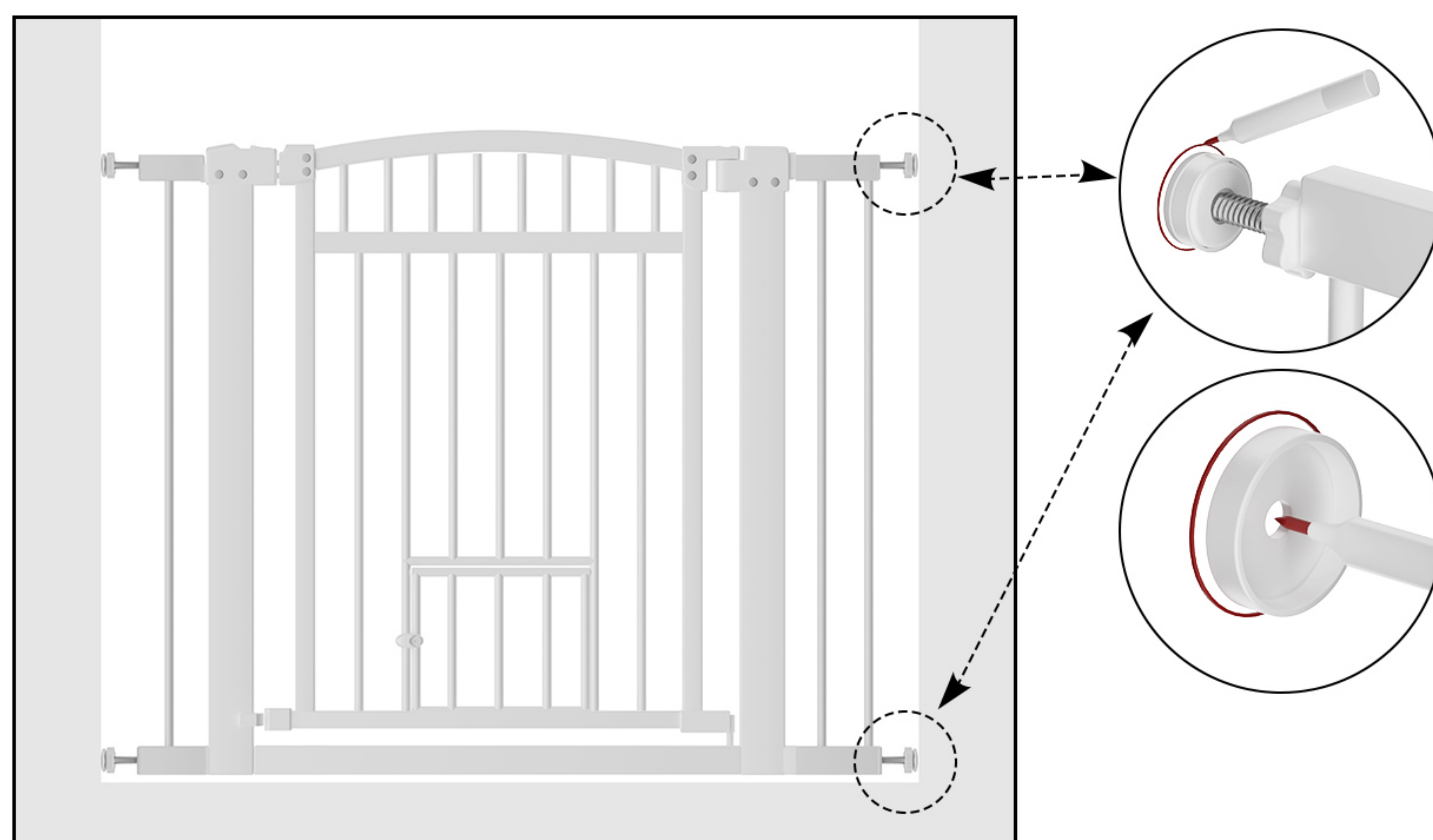
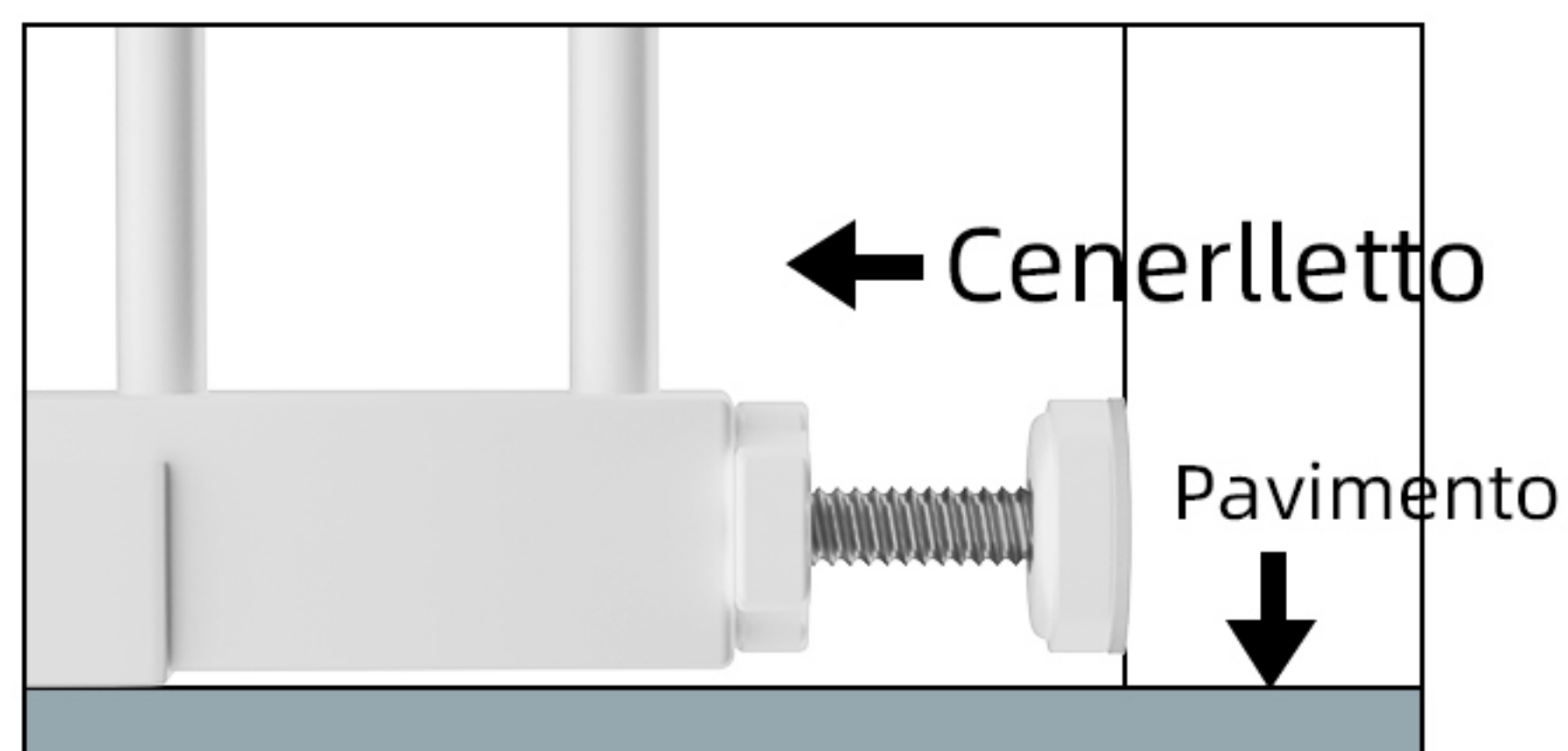
**Fase 2.**

Strisce adesive quando si utilizza l'installazione a pressione. Rimuovere due lati delle strisce adesive, incollare 4 scodellini a muro. Poi utilizzare gli scodellini a muro per coprire gli alberini.

SUGGERIMENTO: se ti preoccupi del danneggiamento delle pareti, saltare questa fase.

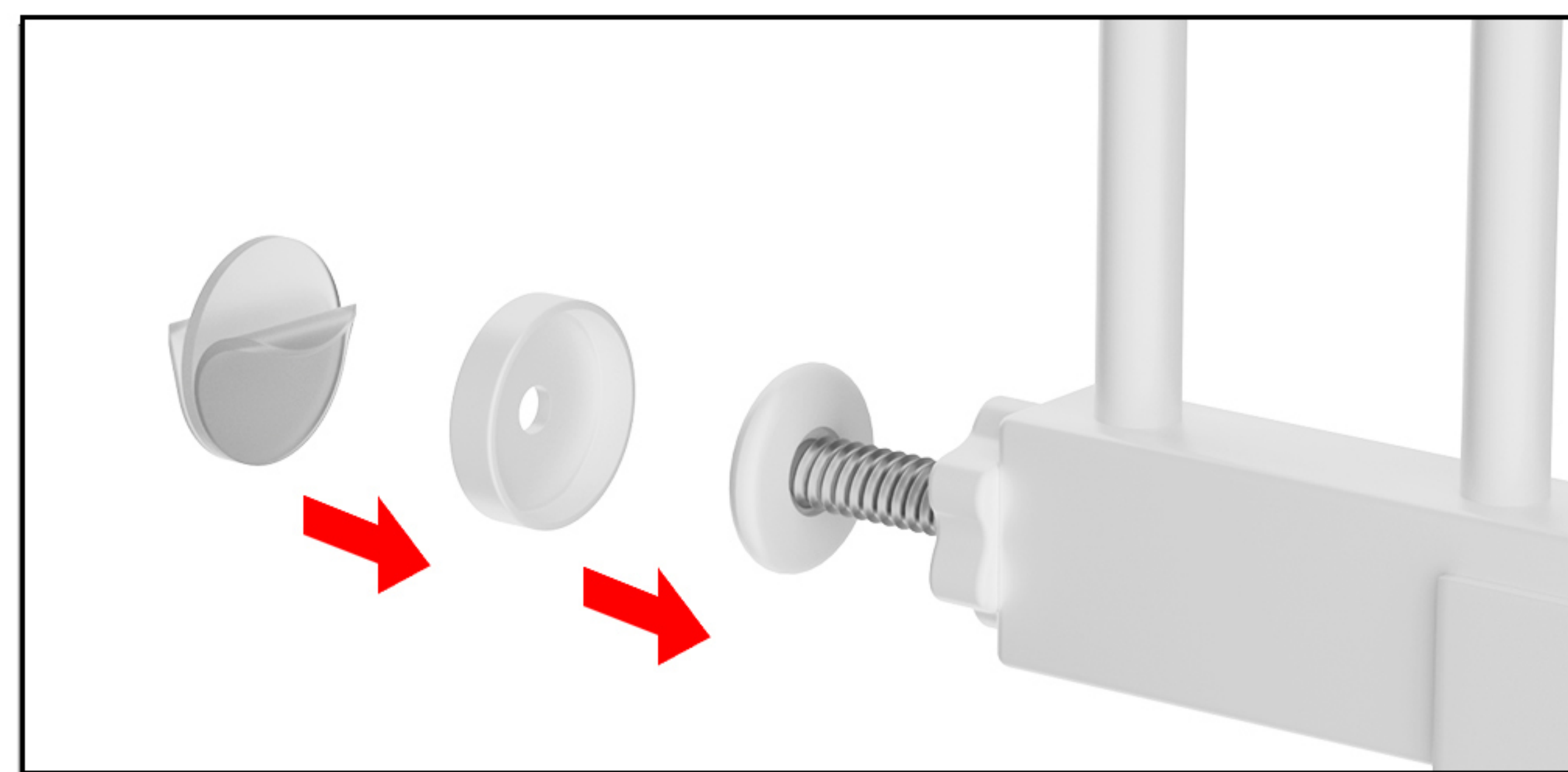
**Fase 3.**

Perforare i fori alle 4 posizioni segnate, e poi inserire l'ancoraggio a vite (g) e utilizzare Vite (f) e lo Scodellino a muro (d)

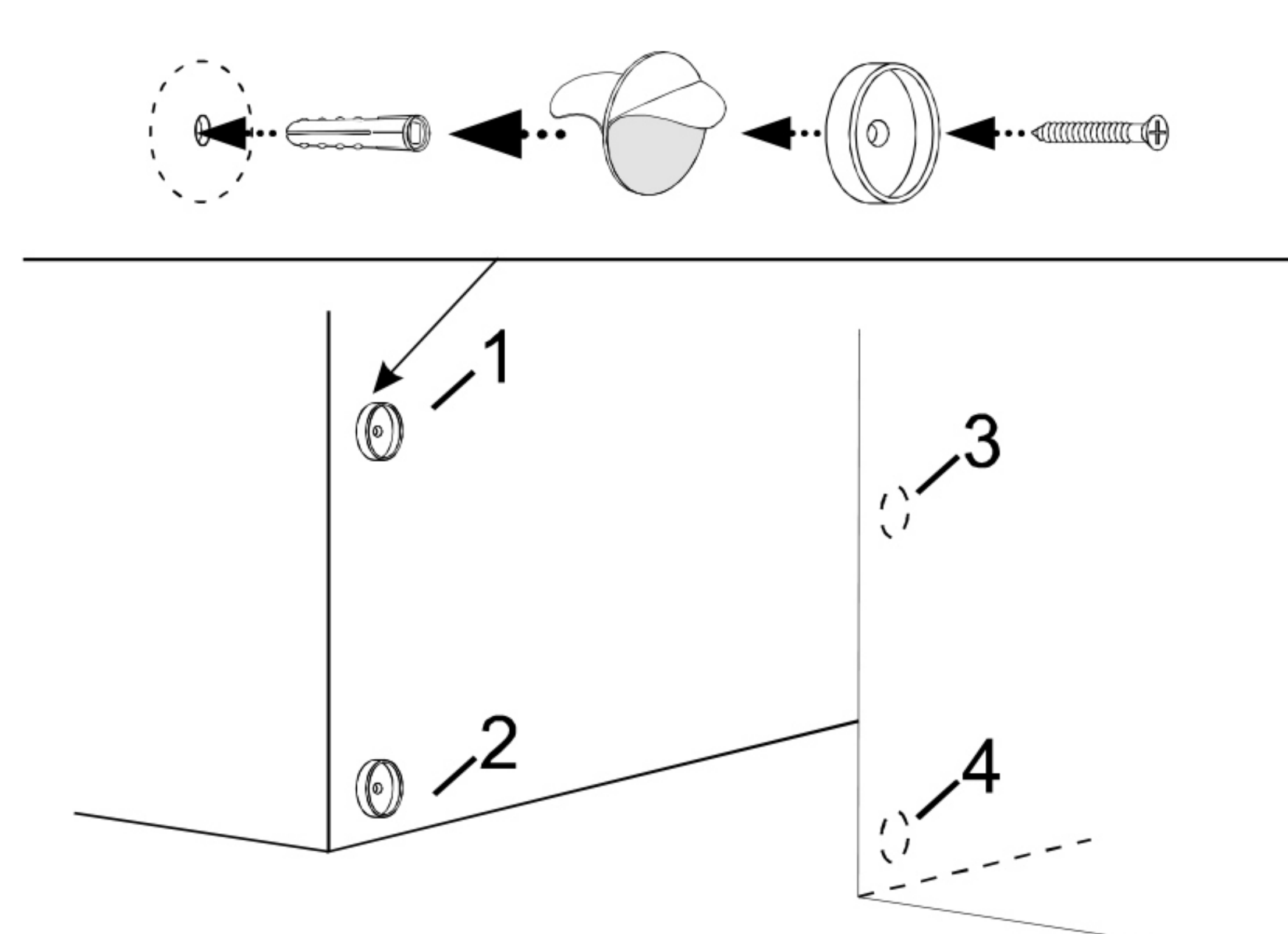
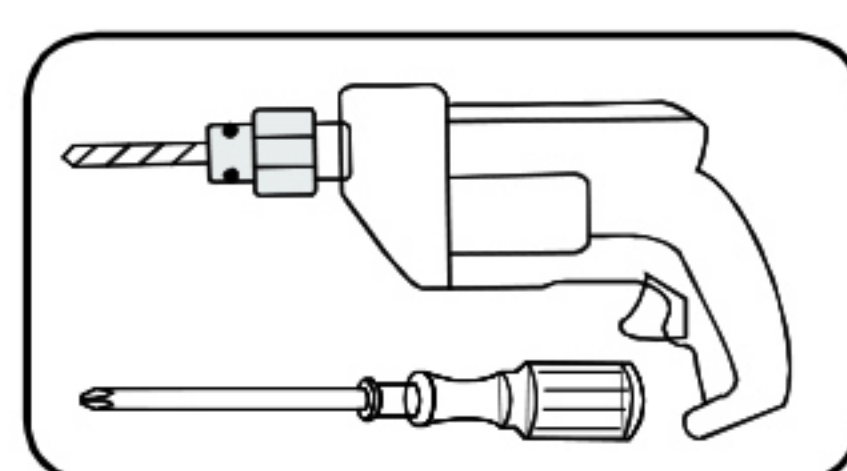
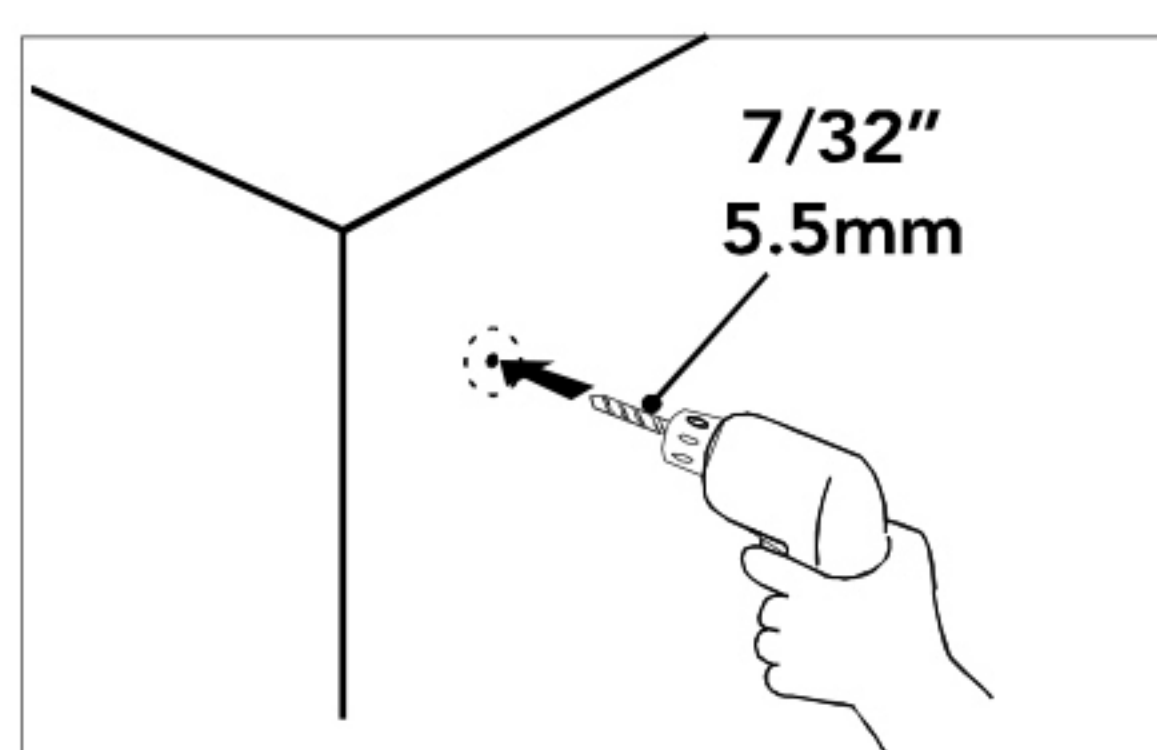

Il prodotto non contiene lo strumento di installazione

Fase 4.

Fase 6. Stringere la parte superiore dei volantini a tensione ruotandoli contemporaneamente in senso orario

Nota: assicurarsi che il fondo del cancelletto resti completamente piatto sul pavimento.

Poi stringere contemporaneamente la parte inferiore dei volantini a tensione in alto ruotandoli in senso orario.

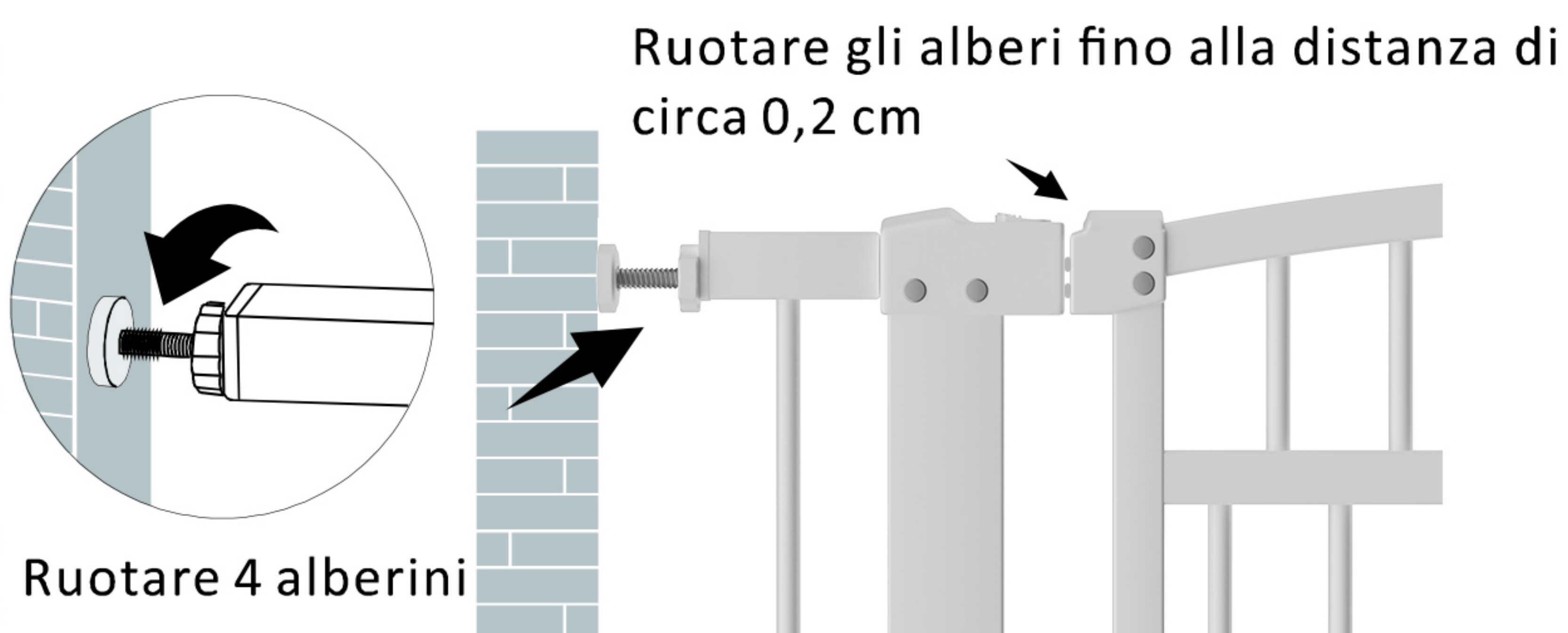

Fase 5.

Tagliare la cintura e Provare il cancelletto:

1. Spingere il cancelletto per verificarne la stabilità.

2. Aprire e chiudere il cancelletto

Metodo di apertura:

Tirare il tasto verso destra, e sollevare il pannello del cancelletto verso l'alto per aprirlo.

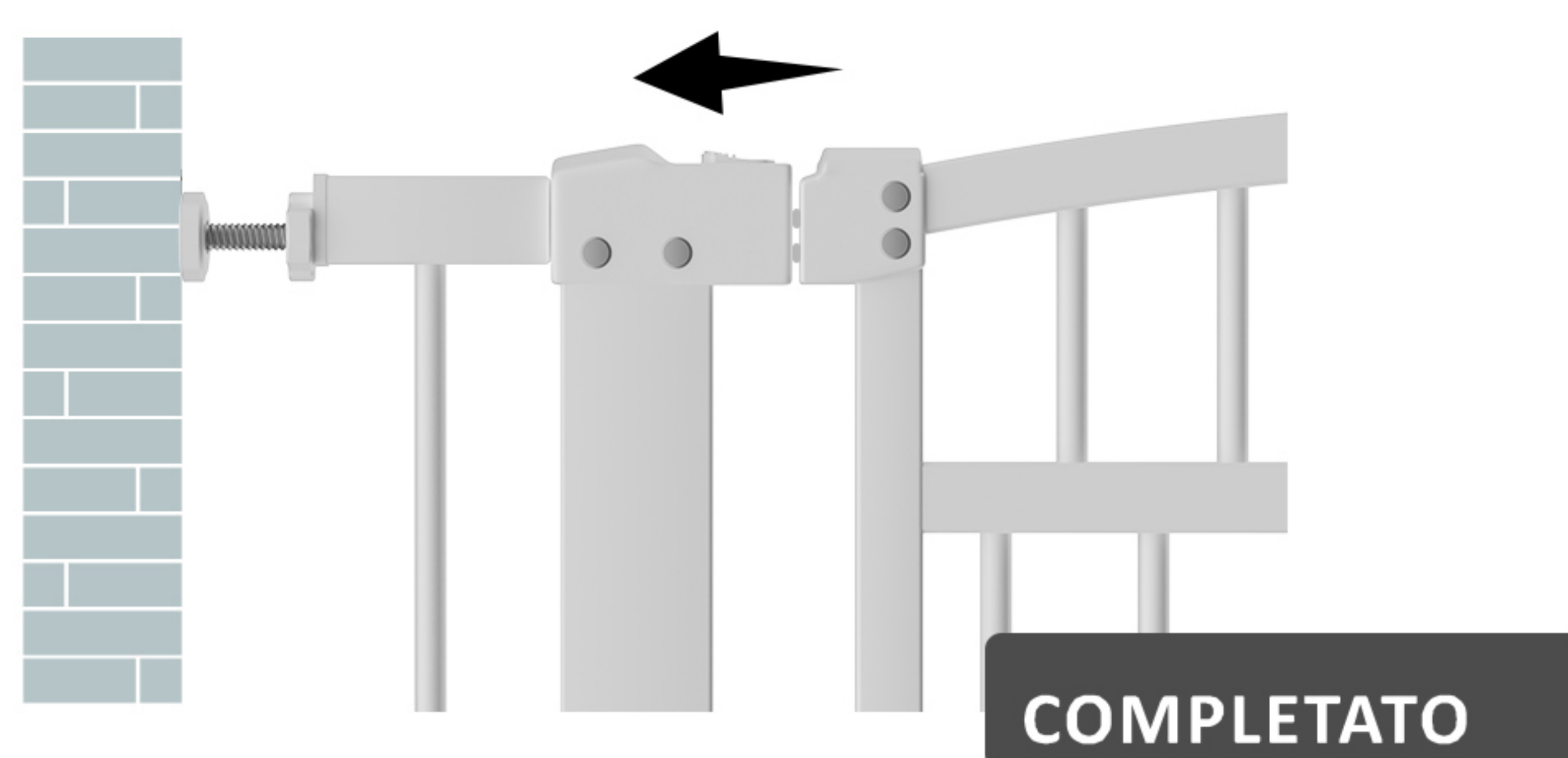

RISOLUZIONE DEI PROBLEMI

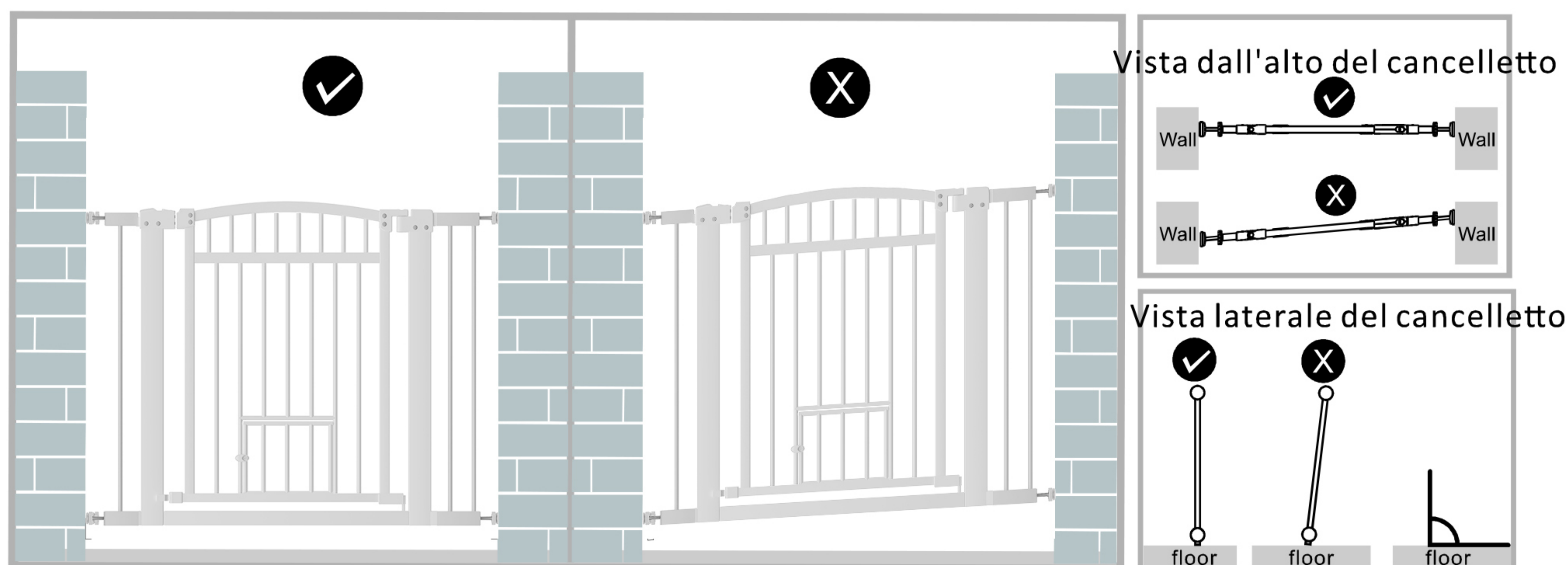

AVVERTENZA

- Per prevenire lesioni gravi o mortali, installare in modo sicuro il cancelletto o la chiusura e l'utilizzo secondo le istruzioni del produttore.
- Utilizzare solo con il meccanismo di blocco saldamente inserito. Interrompere l'utilizzo di cancelletto se alcune parti sono mancanti o danneggiate.
- Installare e utilizzare SEMPRE il cancelletto come indicato utilizzando tutte le parti richieste.
- Controllare periodicamente tutti i dispositivi di fissaggio per assicurarsi che siano stretti e sicuri.
- Assemblaggio degli adulti richiesto.
- Le superfici su cui si fissa il cancelletto devono essere idonee allo scopo e strutturalmente sane.
- Solo per uso interno, non deve essere esposto a elementi esterni.
- Installare questo cancelletto lontano da riscaldatori e altre fonti di calore

If you have any questions, please contact our customer care center, Our contact details are below:

US

 001-877-644-9366

 customerservice@aosom.com

Imported by Aosom LLC
7777 Center Ave. Suite 430
Huntington Beach, CA 92647-9998 USA
MADE IN CHINA

Si tiene alguna pregunta, comuníquese con nuestro Centro de Atención al Cliente, Nuestros datos de contacto son los siguientes:

ES

 0034-931294512

 atencioncliente@aosom.es

IMPORTADOR/Fabricante/REP:
SPANISH AOSOM, S.L.
C/ROC GROS,Nº15.08550, ELS HOSTALETES DE
BALENYÀ, SPAIN.
B66295775
HECHO EN CHINA

If you have any questions, please contact our customer care center, Our contact details are below:

CA

 416-792-6088

 customerservice@aosom.ca

Imported by Aosom Canada Inc.
7270 Woodbine Avenue, Unit 307, Markham,
Ontario Canada L3R 4B9
MADE IN CHINA

Si vous avez la moindre question, veuillez contacter notre centre d'assistance à la clientèle, Nos coordonnées sont les suivantes:

 416-792-6088

 customerservice@aosom.ca

Importé par Aosom Canada Inc.
7270 Woodbine Avenue, unité 307,
Markham, Ontario Canada L3R 4B9
FABRIQUÉ EN CHINE

Se tiver alguma dúvida, por favor contacte o nosso Centro de Atendimento ao Cliente, Os nossos dados de contacto são os seguintes:

 0034-931294512

 info@aosom.pt.

IMPORTADOR/Fabricante/REP:
SPANISH AOSOM, S.L
C.ROC GROS N.15, 08550. ELS HOSTALETES DE
BALENYÀ
FEITO NA CHINA

In caso di dubbio, si prega di contattare il nostro centro assistenza clienti, I nostri dettagli di contatto sono di seguito:

IT

 0039-0249471447

 clienti@aosom.it

IMPORTATO DA/Produttore/REP:
AOSOM Italy srl
Centro Direzionale Milanofiori
Strada 1 Palazzo F1
20057 Assago (MI)
P.I.: 08567220960
FATTO IN CINA

If you have any questions, please contact our customer care center, Our contact details are below:

UK

 0044-800-240-4004

 enquiries@mhstar.co.uk

IMPORTER ADDRESS:
MH STAR UK Ltd
1 Northampton Cross Logistics Park
Northampton Cross Road
Northampton
NN4 9FH
MADE IN CHINA

Wenn Sie Fragen haben, wenden Sie sich bitte an unser Kundendienstzentrum, Unsere Kontaktdaten stehen unten:

DE

 0049-0(40)-87408465

 service@aosom.de

ADRESSE DES IMPORTEURE/Hersteller/REP:
MH Handel GmbH
Wendenstraße 309
D-20537 Hamburg
Germany
IN CHINA HERGESTELLT

Si vous avez la moindre question, veuillez contacter notre centre d'assistance à la clientèle, Nos coordonnées sont les suivantes:

FR

 0033-1-84166106

 aosom@mhfrance.fr

Importé par/Fabricant/REP:
MH FRANCE
2 Rue Maurice Hartmann
92130 Issy Les Moulineaux
France
FABRIQUÉ EN CHINE



Adresses sur quefairedemesdechets.fr