

EN_IMPORTANT, RETAIN FOR FUTURE REFERENCE: READ CAREFULLY.

FR_IMPORTANT: A LIRE ATTENTIVEMENT ET A CONSERVER POUR VOUS Y REFERRER ULTERIEUREMENT

ES_IMPORTANTE, LEA DETENIDAMENTE Y GUARDE PARA FUTURAS REFERENCIAS.

PT_IMPORTANTE, GARDE PARA FUTURA REFERÊNCIA, LEIA ATENTAMENTE.

DE_WICHTIG! SORFGFÄLTIG LESEN UND FÜR SPÄTERES NACHSCHLAGEN AUFBEWAHREN.

IT_IMPORTANTE, LEGGERE E CONSERVARE QUESTO MANUALE D'ISTRUZIONE PER UN USO FUTURO.

RO_IMPORTANT, DE PĂSTRAT PENTRU REFERINȚE VIITOARE: CITIȚI CU ATENȚIE.

EN Operation Instructions

- Please confirm that all components are present before beginning assembly.
- Place all parts on a clean and smooth surface to prevent any damage.
- Do not fully tighten any screws until all screws have been initially tightened. This could cause the frame to warp.
- If wobbling persists or screw holes fail to align, loosen the screws and tighten them sequentially.

FR Instructions pratiques

- Avant de commencer l'assemblage, veuillez confirmer que tous les composants sont présents.
- Placez toutes les pièces sur une surface propre et lisse de manière à éviter tout dommage.
- Ne serrez complètement aucune vis tant que toutes les vis n'ont pas été serrées initialement. Cela pourrait déformer le cadre.
- Si des oscillations persistent ou si les trous de vis ne s'alignent pas, desserrez les vis et serrez-les séquentiellement.

ES Instrucciones de operación

- Por favor, confirme que todos los componentes están presentes antes de comenzar el ensamblaje.
- Coloque todas las piezas sobre una superficie limpia y lisa para evitar daños.
- No apriete completamente ningún tornillo hasta que todos los tornillos hayan sido apretados inicialmente. Esto podría deformar el armazón.
- Si persisten balanceos o los orificios de los tornillos no se alinean, afloje los tornillos y apriételes secuencialmente.

PT Instruções de funcionamento

- Por favor, confirme que todos os componentes estão presentes antes de começar a montagem.
- Coloque todas as peças numa superfície limpa e lisa para evitar danos.
- Não aperte completamente nenhum parafuso até que todos os parafusos tenham sido apertados inicialmente. Isso pode deformar a estrutura.
- Se houver oscilações persistentes ou os furos dos parafusos não se alinharem, afrouxe os parafusos e aperte-os sequencialmente.

DE Betriebsanleitung

- Bitte bestätigen Sie, dass alle Komponenten vor Beginn der Montage vorhanden sind.
- Legen Sie alle Teile auf eine saubere und ebene Fläche, um Beschädigungen zu vermeiden.
- Ziehen Sie keine Schrauben vollständig an, bis alle Schrauben zunächst angezogen wurden. Dies könnte den Rahmen verziehen.
- Falls Wackeln anhält oder Schraubenlöcher nicht ausgerichtet sind, lockern Sie die Schrauben und ziehen Sie sie nacheinander an.

IT Istruzioni per l'uso

- Prima di iniziare l'assemblaggio, confermare che tutti i componenti siano presenti.
- Posiziona tutte le parti su una superficie pulita e liscia per evitare danni.
- Non stringere completamente alcuna vite finché tutte le viti non sono state avvitate inizialmente. Ciò potrebbe deformare il telaio.
- Se persistono oscillazioni o i fori delle viti non si allineano, allentare le viti e stringerle sequenzialmente.

RO Instrucțiuni de Utilizare

- Vă rugăm să confirmați că toate componentele sunt prezente înainte de a începe asamblarea.
- Așezați toate piesele pe o suprafață curată și netedă pentru a preveni orice deteriorare.
- Nu strângeți complet nicio șurub până când toate șuruburile nu au fost strânse inițial. Acest lucru ar putea provoca deformarea cadrului.
- Dacă balansarea persistă sau găurile pentru șuruburi nu se aliniază, slăbiți șuruburile și strângeți-le secvențial.

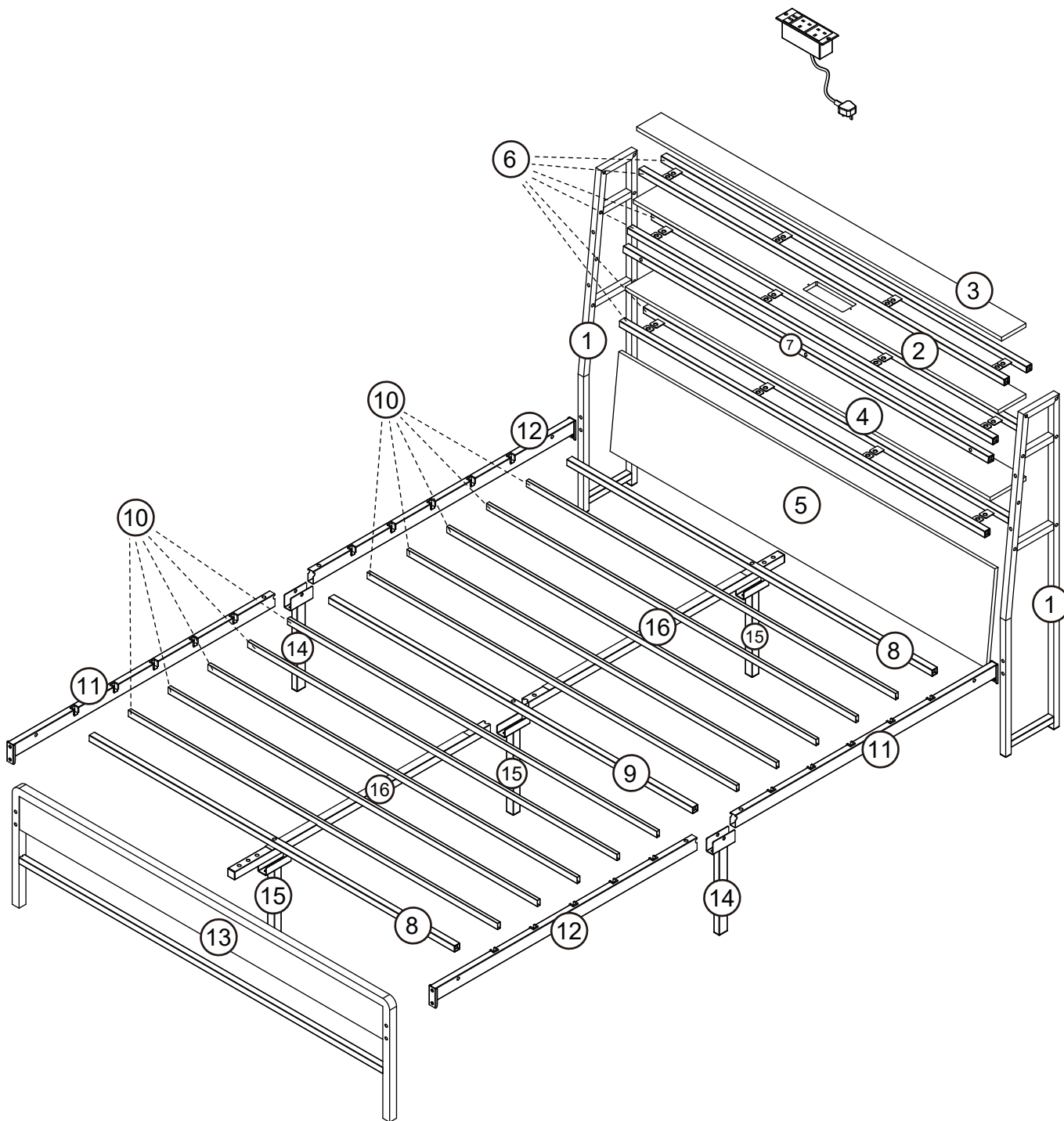

① X2

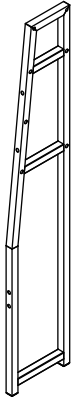

② X1

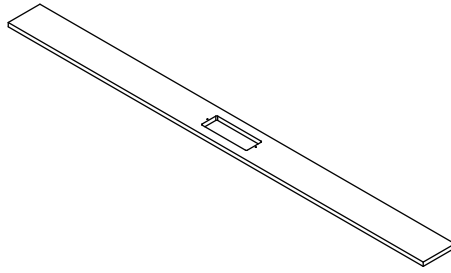

③ X1

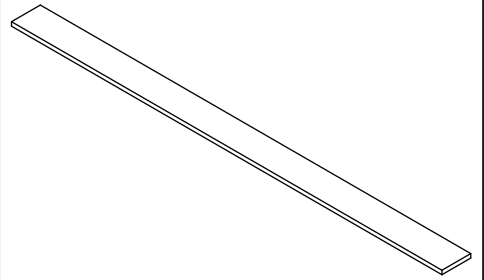

④ X1

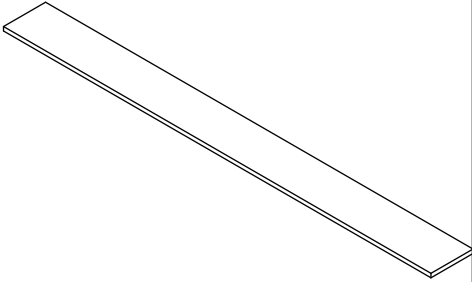

⑤ X1

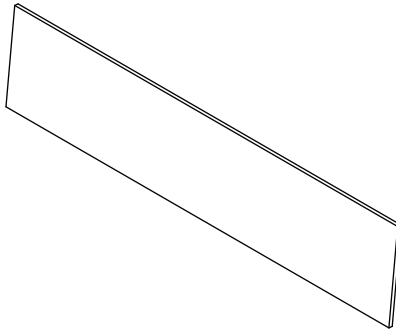

⑥ X6

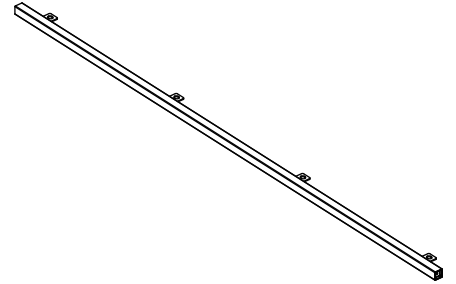

⑦ X1

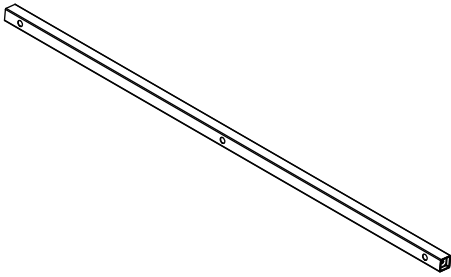

⑧ X2

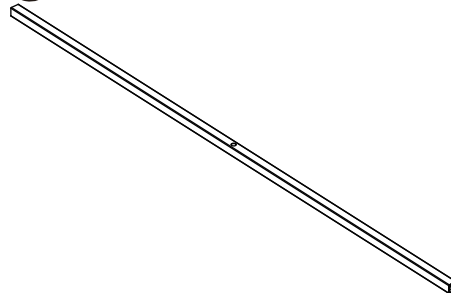

⑨ X1

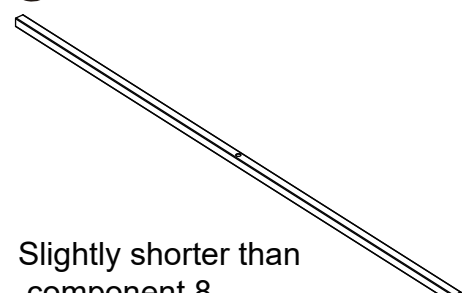

Slightly shorter than component 8.

⑩ X10

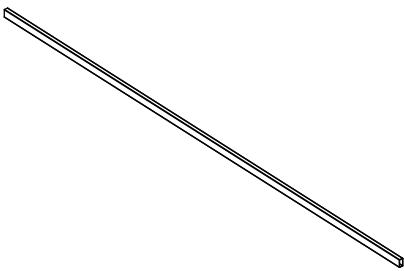

⑪ X2

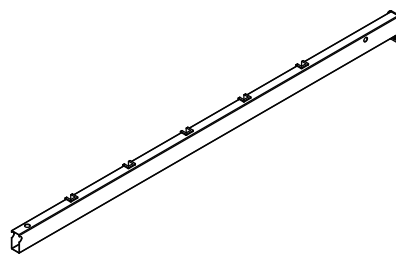

⑫ X2

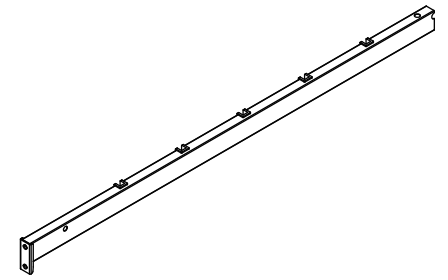

⑬ X1

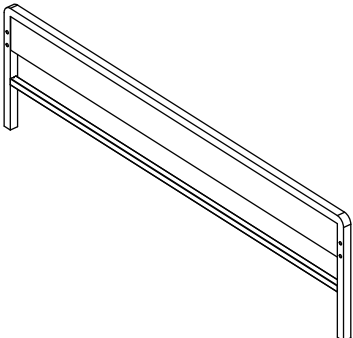

⑭ X2

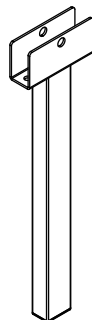

⑮ X3

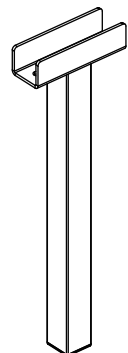

⑯ X2



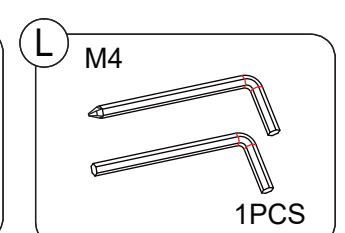
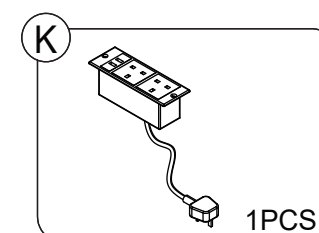
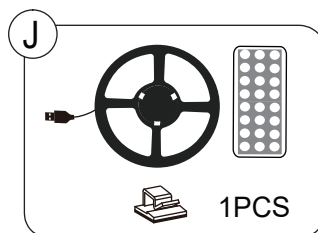
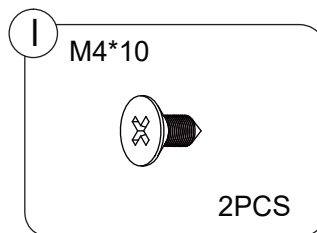
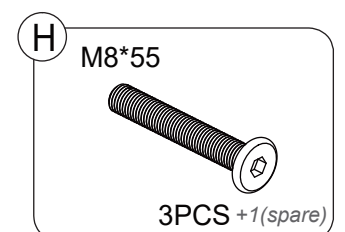
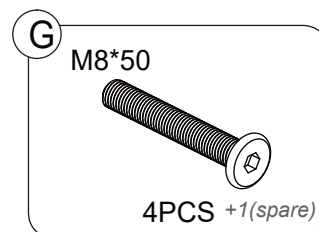
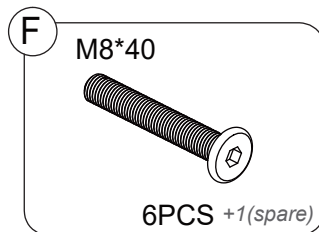
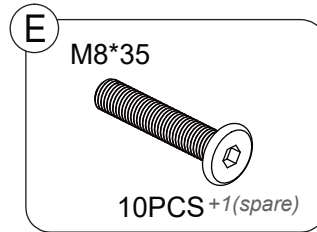
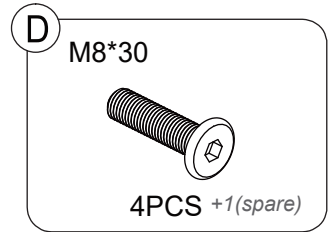
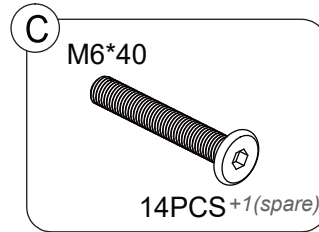
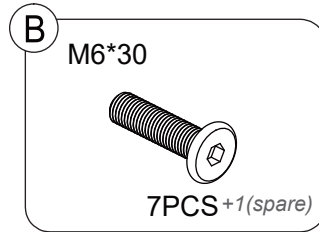
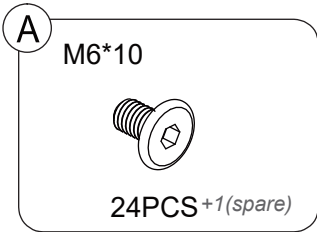

EN: Do not confuse similar screws.
FR: Ne pas confondre des vis similaires.
ES: No confunda tornillos similares.
PT: Não confunda parafusos semelhantes.
DE: Verwechseln Sie ähnliche Schrauben nicht.
IT: Non confondere le viti simili.
RO: Nu confundați șuruburile similare.

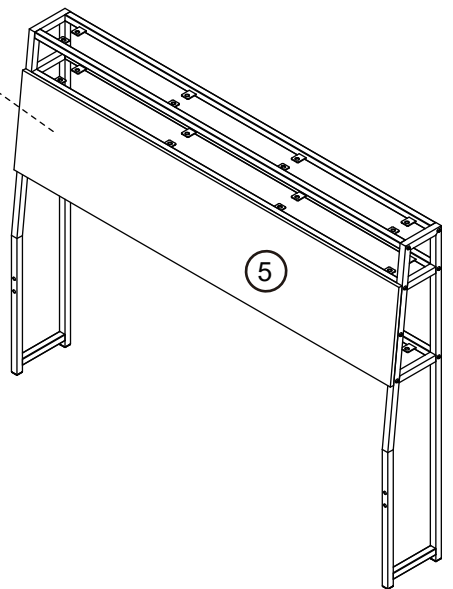
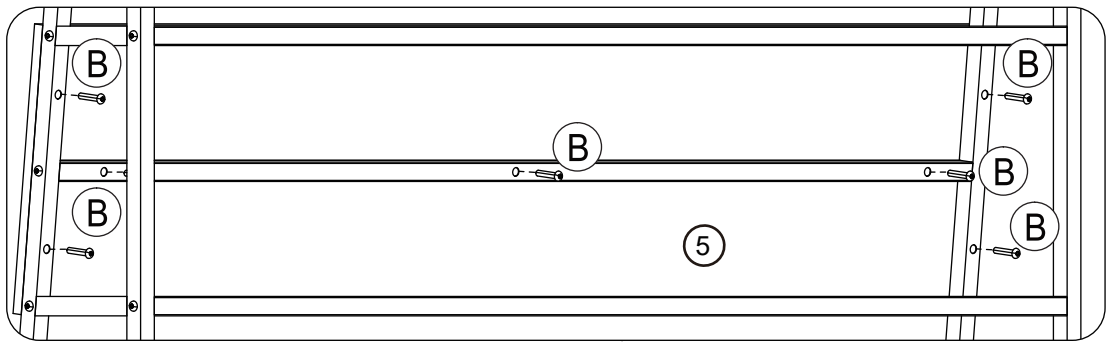
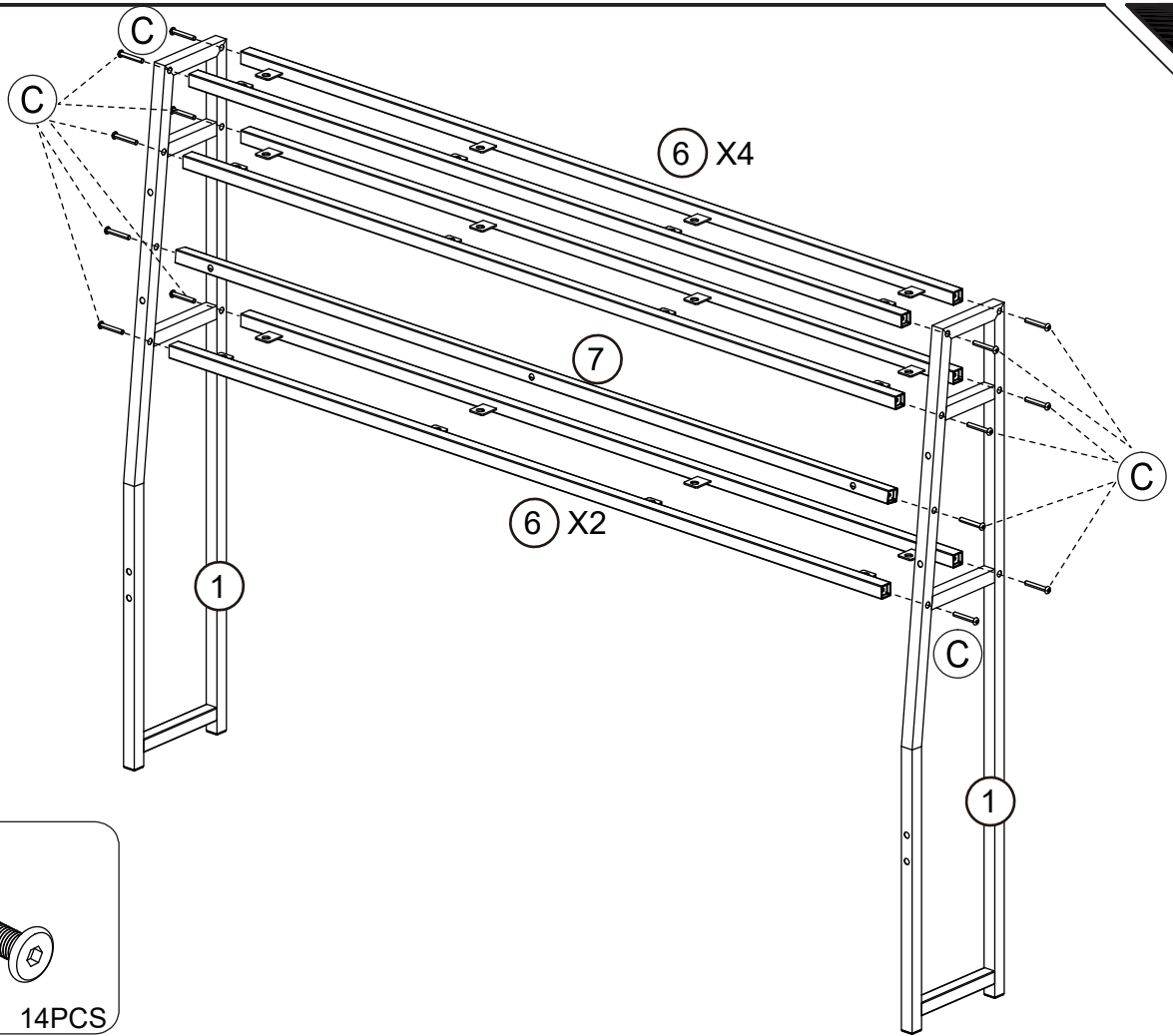

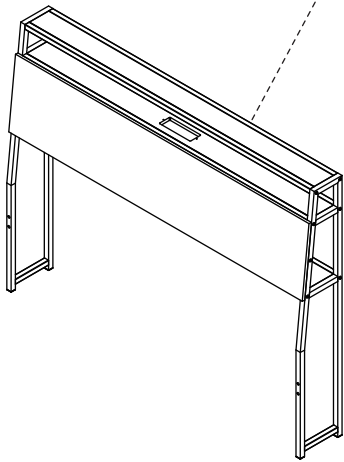
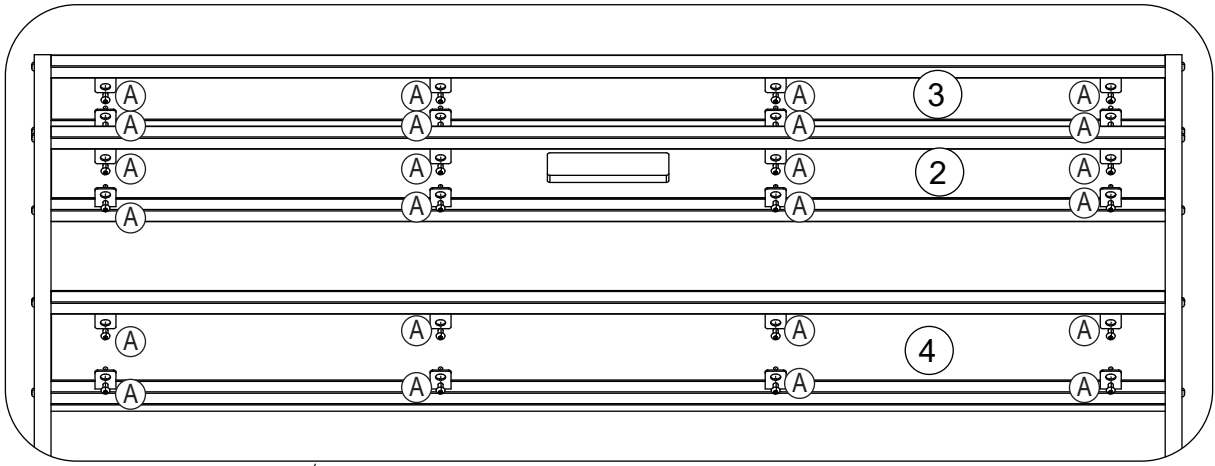

A
M6*10
24PCS

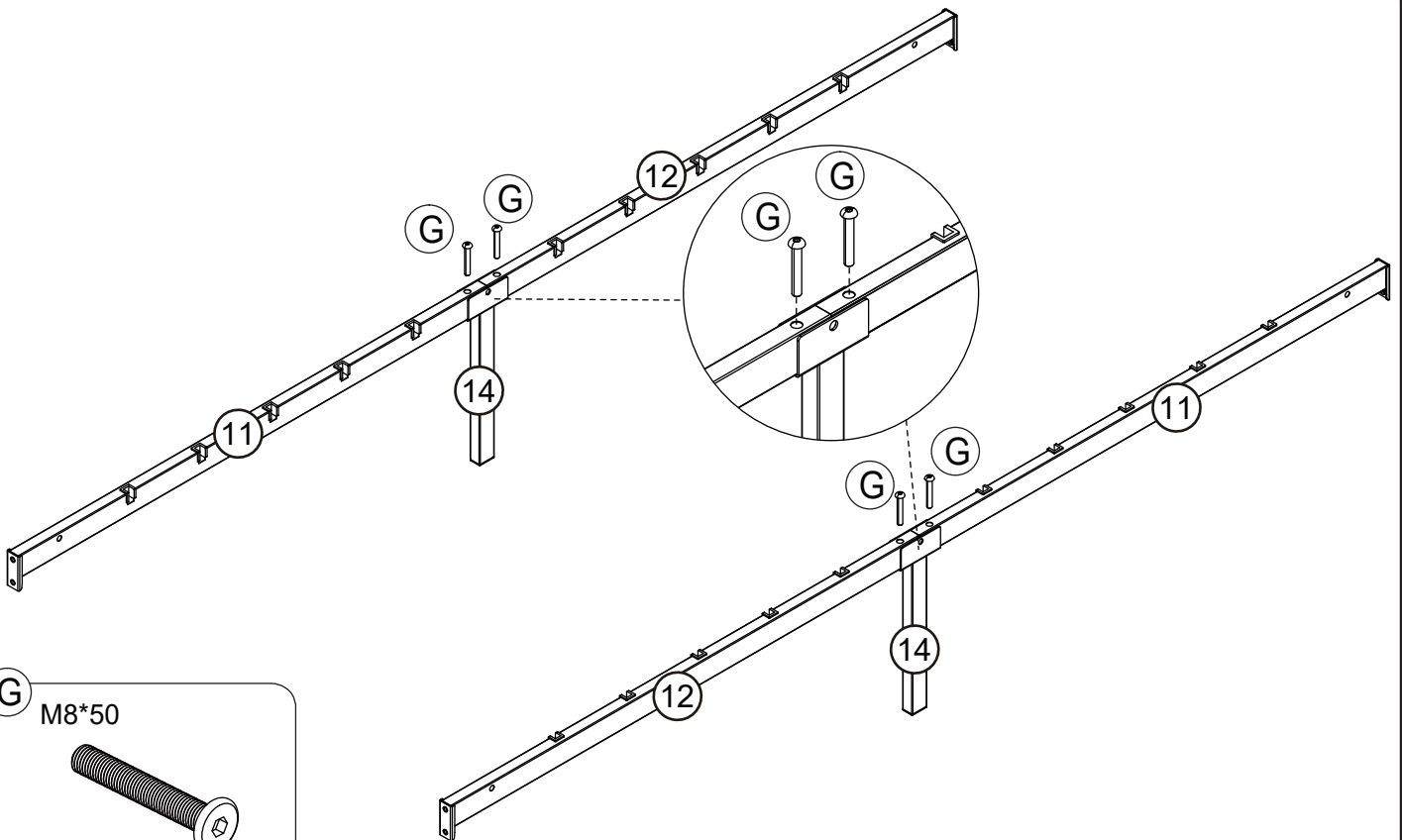

G
M8*50
4PCS

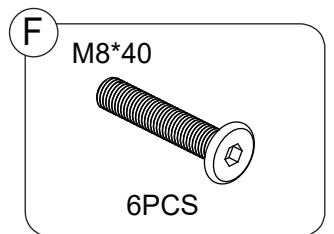
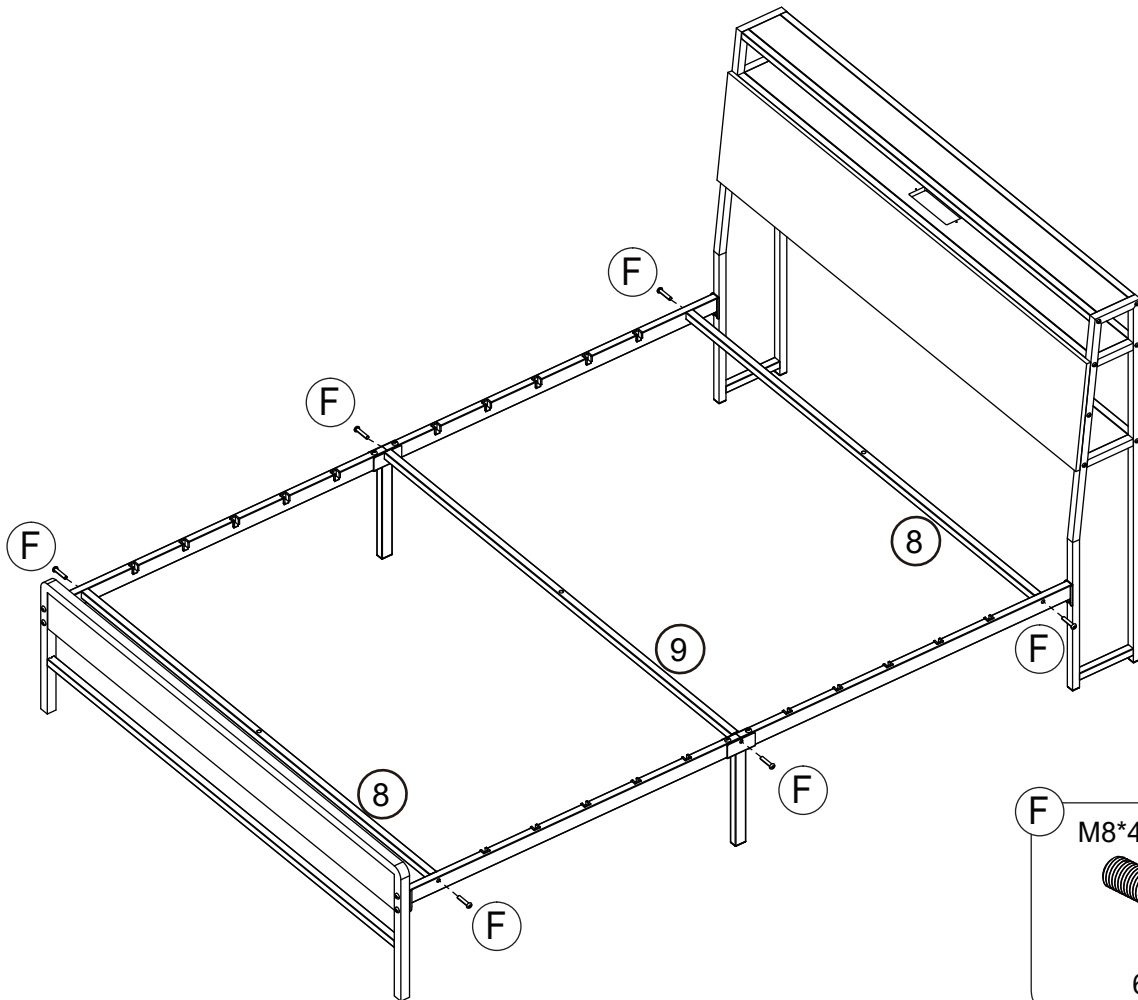
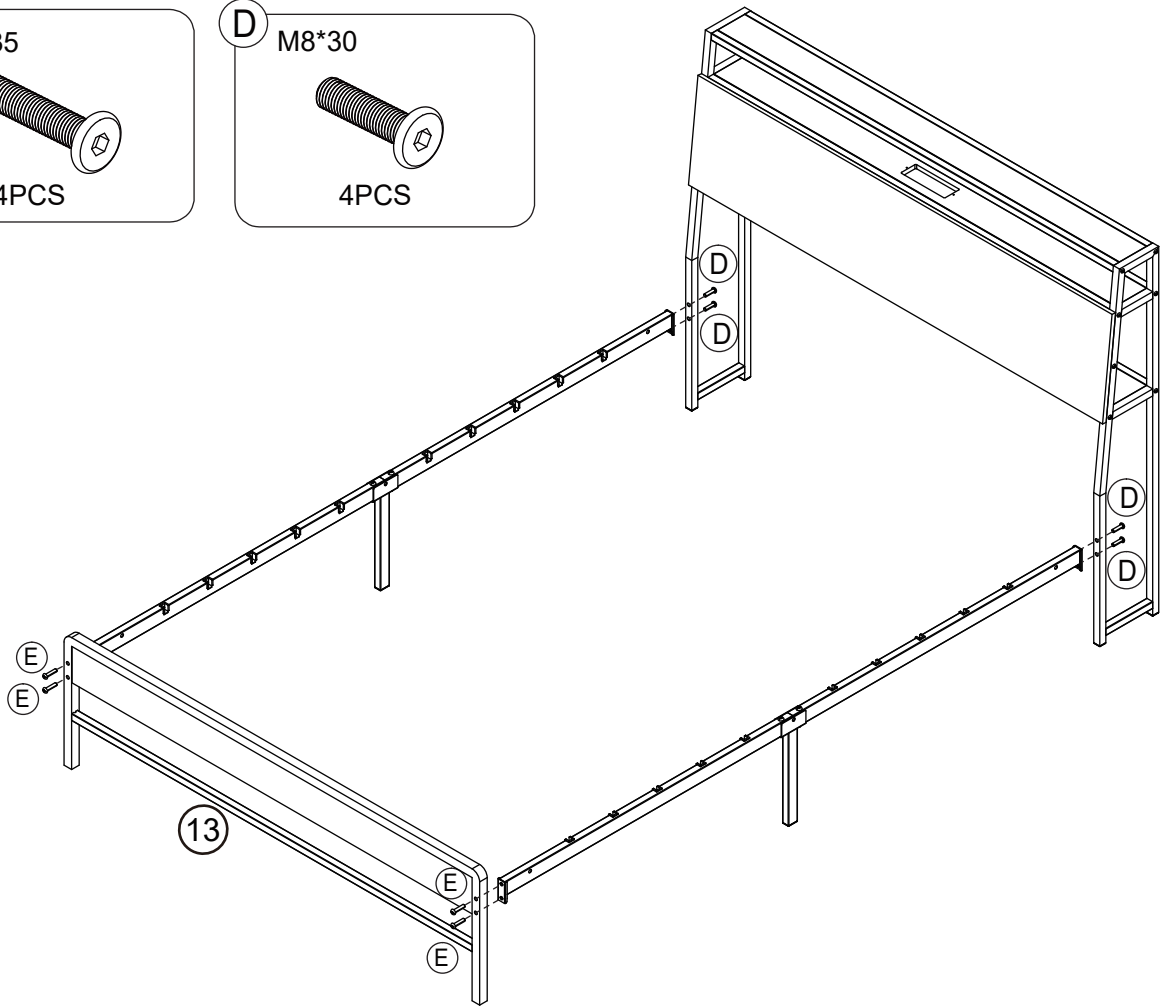
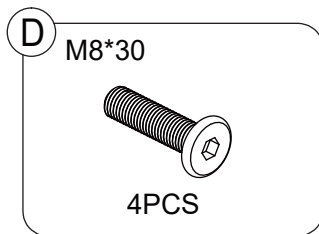
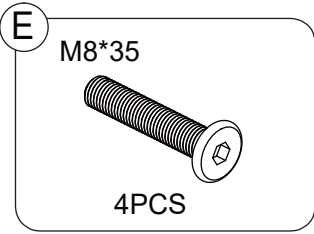

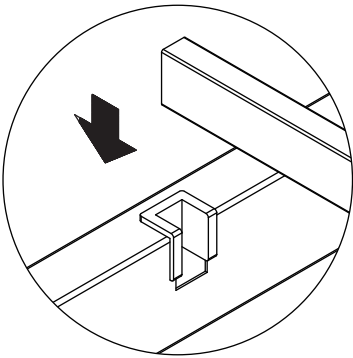
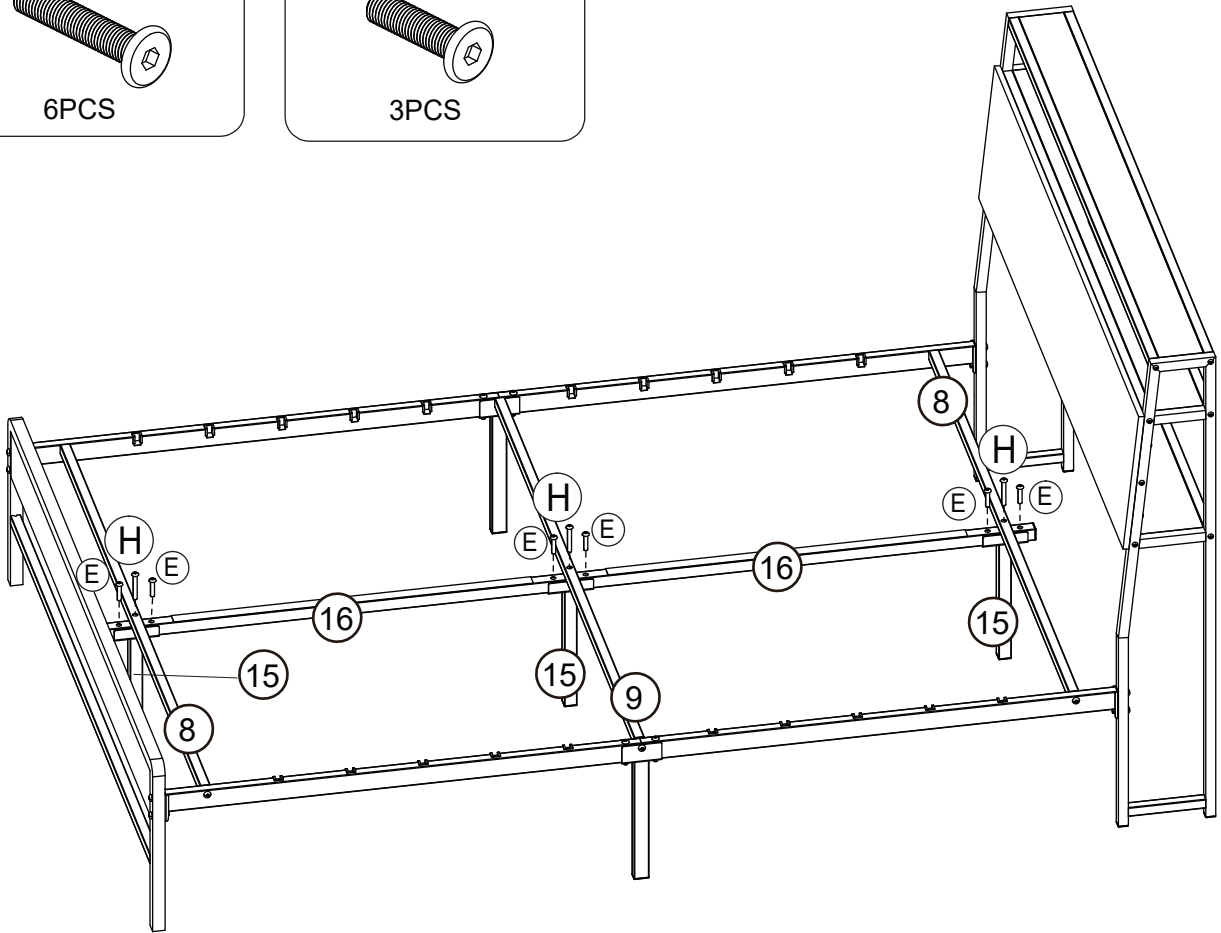
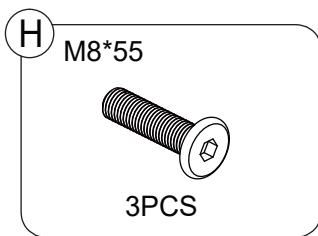
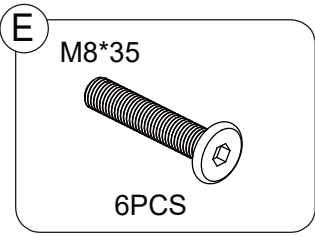

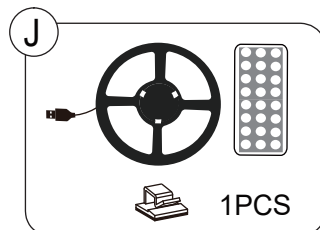
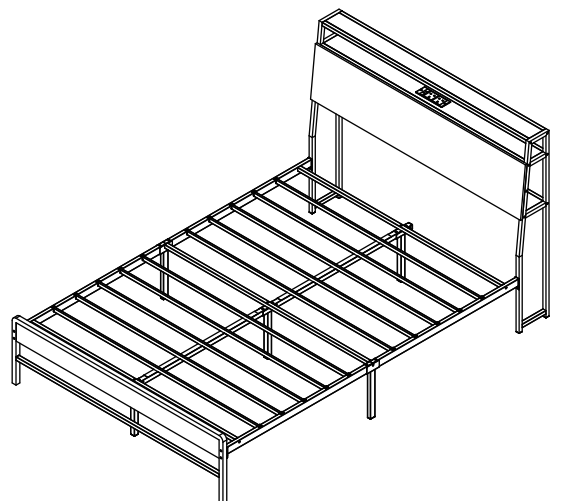
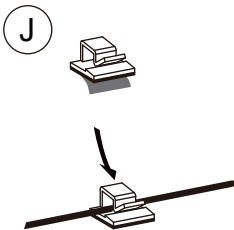
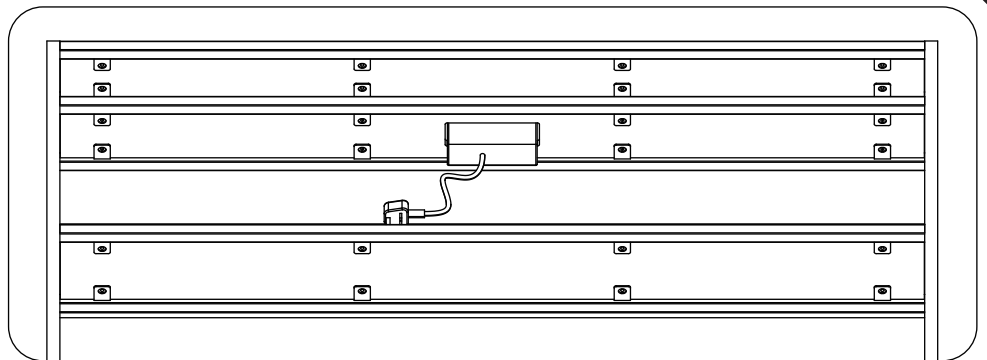
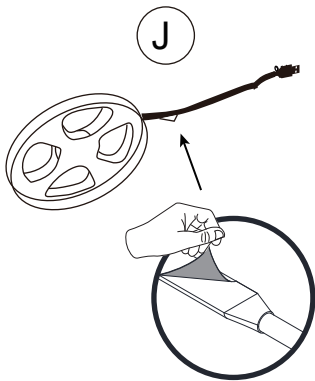
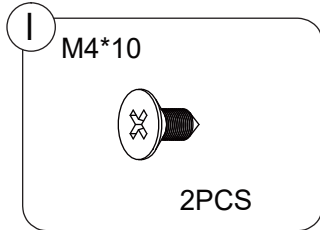
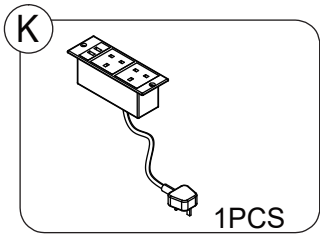
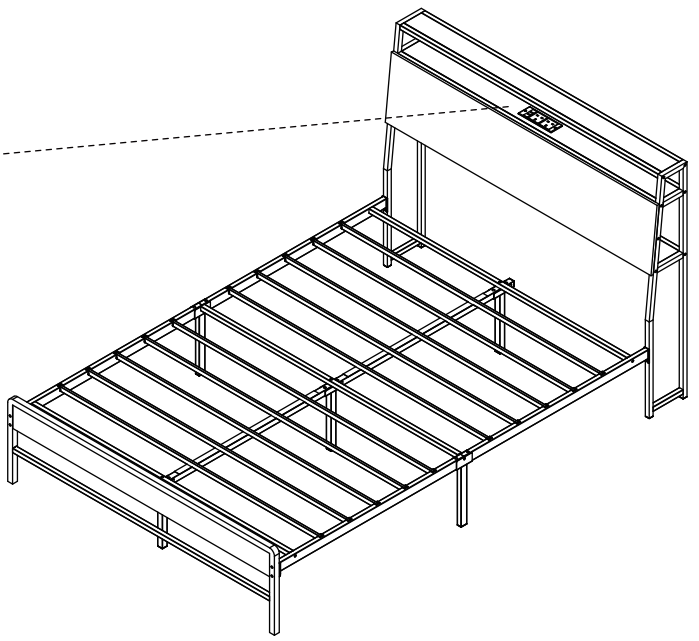
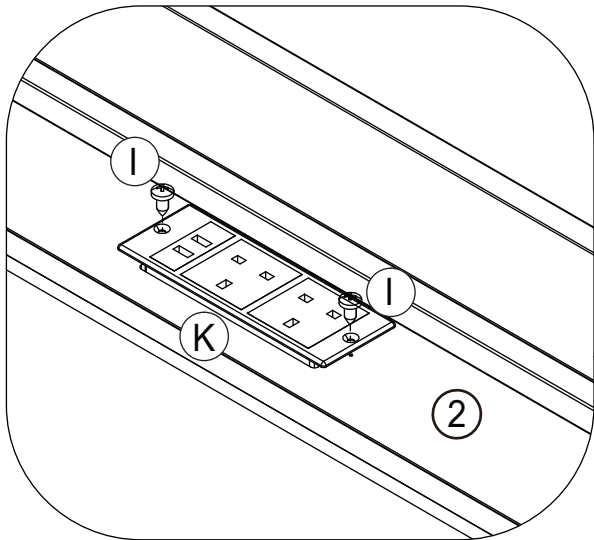

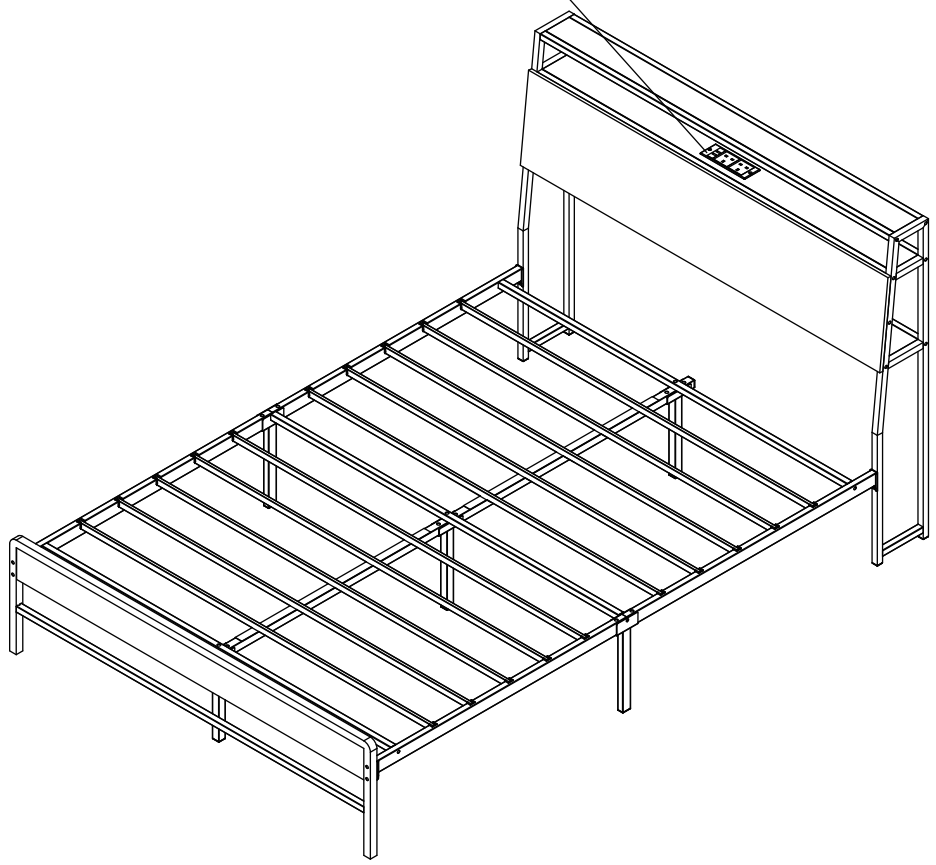
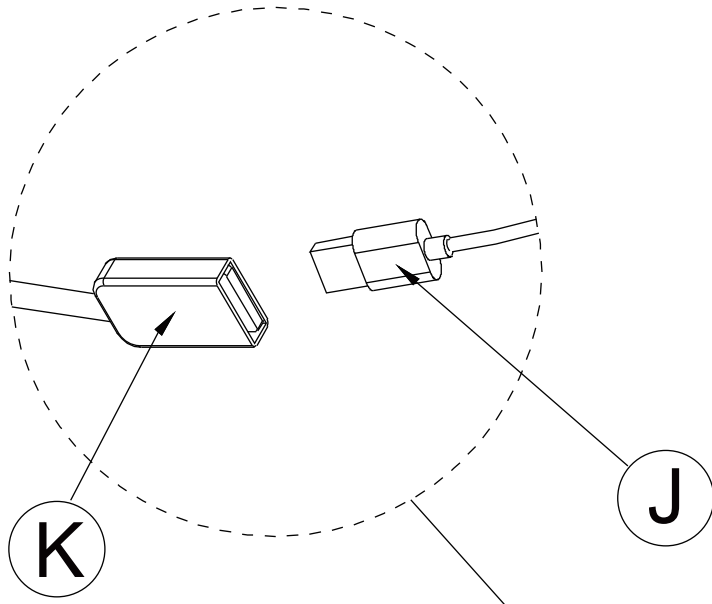

**INDOOR USE ONLY**

- This product contains a light source of energy efficiency class <F>.
- The appliance must only be supplied at safety extra low voltage corresponding to the marking on the appliance.
- If the supply cord is damaged, it must be replaced by the manufacturer, its service agent or similarly qualified persons in order to avoid a hazard.
- To reduce the risk of strangulation the flexible wiring connected to this luminaire shall be effectively fixed to the wall if the wiring is within arm's reach.
- This appliance can be used by children aged from 8 years and above and persons with reduced physical, sensory or mental capabilities or lack of experience and knowledge if they have been given supervision or instruction concerning use of the appliance in a safe way and understand the hazards involved. Children shall not play with the appliance. Cleaning and user maintenance shall not be made by children without supervision.

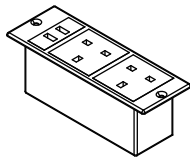
SPECIFICATION

POWER INPUT: 220-240V~50Hz
MAX LOAD: 2400W
USB-A: 5V/2A
Type-C: 5V/3A, 9V/2A, 12V/1.5A

Remote Control Battery (CR2025) **WARNING**

Swallowing hazard: Button battery can cause serious injury or death if swallowed. Keep out of reach of children.

Replace only by adults; observe polarity. Do not short-circuit, charge, disassemble or dispose of in fire.

**Disposal**

Swallowing hazard: Button battery can cause serious injury or death if swallowed. Keep out of reach of children.

Replace only by adults; observe polarity. Do not short-circuit, charge, disassemble or dispose of in fire.

**À USAGE INTÉRIEUR EXCLUSIVEMENT**

- Ce produit contient une source lumineuse de classe d'efficacité énergétique <F>.
- L'appareil doit être alimenté uniquement sous la très basse tension de sécurité correspondant au marquage de l'appareil.
- Si le câble d'alimentation est endommagé, il doit être remplacé par le fabricant, son service après vente ou des personnes de qualification similaire afin d'éviter un danger.
- Pour réduire le risque d'étranglement, le câblage souple raccordé à ce luminaire doit être fixé efficacement au mur si le câblage se situe dans le volume d'accessibilité au toucher.
- Cet appareil peut être utilisé par des enfants âgés d'au moins 8 ans et par des personnes ayant des capacités physiques, sensorielles ou mentales réduites ou dénuées d'expérience ou de connaissance, s'ils (si elles) sont correctement surveillé(e)s ou si des instructions relatives à l'utilisation de l'appareil en toute sécurité leur ont été données et si les risques encourus ont été appréhendés. Les enfants ne doivent pas jouer avec l'appareil. Le nettoyage et l'entretien par l'utilisateur ne doivent pas être effectués par des enfants sans surveillance.

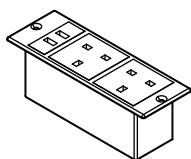
SPÉCIFICATIONS

ALIMENTATION : 220–240 V~50 Hz

CHARGE MAXIMALE : 2400 W

USB-A : 5V/2A

Type-C : 5V/3A, 9V/2A, 12V/1.5A

Pile de la télécommande (CR2025)**AVERTISSEMENT**

Risque d'ingestion : Une pile bouton peut causer des blessures graves ou la mort si elle est avalée. Gardez hors de portée des enfants.

Remplacez uniquement par des adultes ; respectez la polarité. Ne pas court-circuiter, recharger, démonter ou jeter au feu.

**Élimination**

Les piles ne doivent pas être jetées avec les déchets ménagers car elles peuvent contenir des substances nocives pour l'environnement et la santé. Les piles usées peuvent être déposées dans des points de collecte publics de la commune ou les centres de recyclage de votre région.

**NUR ZUR VERWENDUNG IN INNENRÄUMEN**

- Dieses Produkt enthält eine Lichtquelle der Energieeffizienzklasse <F>.
- Das Gerät ist nur mit SELV entsprechend der Kennzeichnung auf dem Gerät zu versorgen.
- Wenn die Netzanschlussleitung dieses Gerätes beschädigt wird, muss sie durch den Hersteller oder seinen Kundendienst oder eine ähnlich qualifizierte Person ersetzt werden, um Gefährdungen zu vermeiden.
- Um die Gefahr einer Strangulierung zu verringern, müssen die an dieser Leuchte angeschlossenen flexiblen Kabel wirksam an der Wand befestigt werden, wenn sich die Kabel in Reichweite der Arme befinden.
- Dieses Gerät kann von Kindern ab 8 Jahren und darüber sowie von Personen mit verringerten physischen, sensorischen oder mentalen Fähigkeiten oder Mangel an Erfahrung und Wissen benutzt werden, wenn sie beaufsichtigt oder bezüglich des sicheren Gebrauchs des Gerätes unterwiesen wurden und die daraus resultierenden Gefahren verstehen. Kinder dürfen nicht mit dem Gerät spielen. Reinigung und Benutzer-Wartung dürfen nicht von Kindern ohne Beaufsichtigung durchgeführt werden.

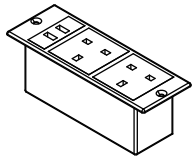
SPEZIFIKATIONEN

NETZEINGANG: 220–240 V~50 Hz

MAXIMALE LAST: 2400 W

USB-A: 5V/2A

Type-C: 5V/3A, 9V/2A, 12V/1.5A

Fernbedienungsatterie (CR2025)**! WARNUNG**

Verschluckungsgefahr: Knopfzellenbatterien können schwere Verletzungen oder den Tod verursachen, wenn sie verschluckt werden. Außerhalb der Reichweite von Kindern aufbewahren.

Nur von Erwachsenen ersetzen; Polarität beachten. Nicht kurzschließen, aufladen, zerlegen oder ins Feuer werfen.

**Entsorgung**

Batterien dürfen nicht über den Hausmüll entsorgt werden, da sie umwelt- und gesundheitsschädliche Stoffe enthalten können. Verbrauchte Batterien können bei öffentlichen Sammelstellen oder Recyclingzentren in Ihrer Region abgegeben werden.

**USO SOLO EN INTERIORES**

- Este producto contiene una fuente de luz de clase de eficiencia energética <F>.
- El aparato solo debe alimentarse con una tensión de seguridad extra baja, conforme a la indicación marcada en el mismo.
- Si el cable de alimentación está dañado, debe ser reemplazado por el fabricante, su agente de servicio o personas igualmente calificadas para evitar un peligro.
- Para reducir el riesgo de estrangulamiento, el cableado flexible conectado a esta luminaria debe fijarse eficazmente a la pared si el cableado está al alcance de la mano.
- Este aparato puede ser utilizado por niños a partir de 8 años y por personas con capacidades físicas, sensoriales o mentales reducidas o con falta de experiencia y conocimientos, siempre que hayan recibido supervisión o instrucciones sobre el uso seguro del aparato y comprendan los riesgos que conlleva. Los niños no deben jugar con el aparato. La limpieza y el mantenimiento por parte del usuario no deben ser realizados por niños sin supervisión.

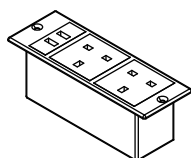
Especificaciones

ENTRADA DE ALIMENTACIÓN: 220–240 V~50 Hz
CARGA MÁXIMA: 3680 W
USB-A: 5V/2A
Type-C: 5V/3A, 9V/2A, 12V/1.5A

Batería del control remoto (CR2025)**⚠ ADVERTENCIA**

Riesgo de ingestión: La batería de botón puede causar lesiones graves o la muerte si se ingiere. Manténgala fuera del alcance de los niños.

Sustitúyala únicamente por adultos; respete la polaridad. No la cortocircuite, recargue, desmonte ni arroje al fuego.

**Eliminación**

Las baterías no deben desecharse con los residuos domésticos, ya que pueden contener sustancias perjudiciales para el medio ambiente y la salud. Las baterías agotadas pueden depositarse en puntos públicos de recogida o centros de reciclaje en su área.

**USO APENAS EM INTERIORES.**

- Este produto contém uma fonte luminosa de classe de eficiência energética <F>.
- O aparelho só deve ser alimentado com tensão de segurança extra baixa, conforme indicado na marcação do próprio aparelho.
- Se o cabo de alimentação estiver danificado, ele deve ser substituído pelo fabricante, seu agente de serviço ou pessoas igualmente qualificadas para evitar um perigo.
- Para reduzir o risco de estrangulamento, a cablagem flexível ligada a esta luminária deve ser fixada de forma eficaz à parede, se a cablagem estiver ao alcance da mão.
- Este aparelho pode ser utilizado por crianças com idade igual ou superior a 8 anos e por pessoas com capacidades físicas, sensoriais ou mentais reduzidas ou com falta de experiência e conhecimento, desde que tenham recebido supervisão ou instruções sobre a utilização segura do aparelho e compreendam os riscos envolvidos. As crianças não devem brincar com o aparelho. A limpeza e a manutenção pelo utilizador não devem ser feitas por crianças sem supervisão.

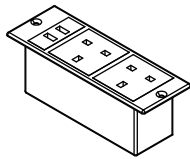
Especificações

ENTRADA DE ALIMENTAÇÃO: 220–240 V ~ 50 Hz

CARGA MÁXIMA: 2400 W

USB-A: 5V/2A

Type-C: 5V/3A, 9V/2A, 12V/1.5A

Bateria do controle remoto (CR2025)**ADVERTÊNCIA**

Perigo de ingestão: A bateria de botão pode causar ferimentos graves ou morte se ingerida. Mantenha fora do alcance de crianças.

Substitua apenas por adultos; observe a polaridade. Não provoque curto-circuito, carregue, desmonte ou descarte no fogo.

**Descarte**

As baterias não devem ser descartadas com resíduos domésticos, pois podem conter substâncias prejudiciais para o meio ambiente e a saúde. Baterias esgotadas podem ser entregues em pontos públicos de recolha ou centros de reciclagem da sua área.

**SOLO PER USO INTERNO**

- Questo prodotto contiene una sorgente luminosa di classe di efficienza energetica <F>.
- L'apparecchio deve essere alimentato soltanto con tensione di sicurezza extra bassa, conforme alla marcatura riportata sull'apparecchio stesso.
- **Se il cavo di alimentazione è danneggiato, deve essere sostituito dal produttore, dal suo agente di servizio o da persone altrettanto qualificate per evitare pericoli.**
- Per ridurre il rischio di strangolamento, il cavo flessibile collegato a questo apparecchio deve essere fissato saldamente alla parete se si trova a portata di mano.
- Questo apparecchio può essere utilizzato da bambini di età superiore agli 8 anni e da persone con capacità fisiche, sensoriali o mentali ridotte o con mancanza di esperienza e conoscenza, purché siano stati istruiti o sorvegliati sull'uso sicuro dell'apparecchio e comprendano i pericoli che esso comporta. I bambini non devono giocare con l'apparecchio. La pulizia e la manutenzione da parte dell'utente non devono essere effettuate da bambini senza supervisione.

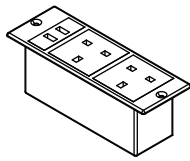
Specifiche

INGRESSO ALIMENTAZIONE: 220–240 V ~ 50 Hz

CARICO MASSIMO: 2400 W

USB-A: 5V/2A

Type-C: 5V/3A, 9V/2A, 12V/1.5A

Batteria del telecomando (CR2025)**AVVERTENZE**

Pericolo di ingestione: La batteria a bottone può causare lesioni gravi o morte se ingerita. Tenere fuori dalla portata dei bambini.

Sostituire solo da adulti; osservare la polarità. Non cortocircuitare, ricaricare, smontare né gettare nel fuoco.

**Smaltimento**

Le batterie non devono essere smaltite con i rifiuti domestici, poiché possono contenere sostanze dannose per l'ambiente e la salute. Le batterie esauste possono essere consegnate a punti di raccolta pubblici o a centri di riciclaggio della vostra zona.

**NUMAI PENTRU UZ INTERIOR**

- Acest produs conține o sursă de lumină din clasa de eficiență energetică .
- Aparatul trebuie alimentat doar la o tensiune extra-redușă de siguranță, corespunzătoare marcajului de pe aparat.
- Dacă cablul de alimentare este deteriorat, acesta trebuie înlocuit de către producător, agentul său de service sau persoane cu calificări similare, pentru a evita un pericol.
- Pentru a reduce riscul de strangulare, cablajul flexibil conectat la acest corp de iluminat trebuie fixat efectiv pe perete dacă se află la îndemână.
- Acest aparat poate fi utilizat de copii cu vârsta de peste 8 ani și de persoane cu capacități fizice, senzoriale sau mentale reduse sau cu lipsă de experiență și cunoștințe, dacă aceștia au fost supravegheați sau instruiți cu privire la utilizarea aparatului în condiții de siguranță și înțeleg pericolele implicate. Copiii nu trebuie să se joace cu aparatul. Curățarea și întreținerea de către utilizator nu trebuie efectuate de copii fără supraveghere.

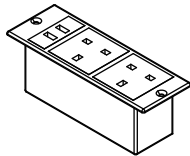
SPECIFICAȚII TEHNICE

ALIMENTARE: 220-240V~50Hz
SARCINĂ MAXIMĂ: 2400W
USB-A: 5V/2A
Type-C: 5V/3A, 9V/2A, 12V/1.5A

Baterie telecomandă (CR2025)**AVERTISMENT**

Pericol de înghițire: Bateriile tip buton pot provoca vătămări grave sau deces dacă sunt înghițite. A nu se lăsa la îndemâna copiilor.

Înlocuirea se face doar de către adulți; respectați polaritatea. Nu scurtcircuitați, nu încărcați, nu dezamblați și nu aruncați în foc.

**Dispozitiv de eliminare**

Pericol de înghițire: Bateriile tip buton pot provoca vătămări grave sau deces dacă sunt înghițite. A nu se lăsa la îndemâna copiilor.

Înlocuirea se face doar de către adulți; respectați polaritatea. Nu scurtcircuitați, nu încărcați, nu dezamblați și nu aruncați în foc.

If you have any questions, please contact our customer care center, Our contact details are below:

US

 001-877-644-9366

 customerservice@aosom.com

Imported by Aosom LLC
7777 Center Ave. Suite 430
Huntington Beach, CA 92647-9998 USA
MADE IN CHINA

If you have any questions, please contact our customer care center, Our contact details are below:

CA

 416-792-6088

 customerservice@aosom.ca

Imported by Aosom Canada Inc.
7270 Woodbine Avenue, Unit 307, Markham,
Ontario Canada L3R 4B9
MADE IN CHINA

Si vous avez la moindre question, veuillez contacter notre centre d'assistance à la clientèle, Nos coordonnées sont les suivantes:

 416-792-6088

 customerservice@aosom.ca

Importé par Aosom Canada Inc.
7270 Woodbine Avenue, unité 307,
Markham, Ontario Canada L3R 4B9
FABRIQUÉ EN CHINE

If you have any questions, please contact our customer care center, Our contact details are below:

UK

 0044-800-240-4004

 enquiries@mhstar.co.uk

IMPORTER ADDRESS:
MH STAR UK Ltd
1 Northampton Cross Logistics Park
Northampton Cross Road
Northampton
NN4 9FH
MADE IN CHINA

Si vous avez la moindre question, veuillez contacter notre centre d'assistance à la clientèle, Nos coordonnées sont les suivantes:

FR

 0033-1-84166106

 aosom@mhfrance.fr

Importé par/Fabricant/REP:
MH FRANCE
2 Rue Maurice Hartmann
92130 Issy Les Moulineaux
France
FABRIQUÉ EN CHINE



FR

Cet appareil, ses accessoires, cordons et batteries se recyclent

REPRISE À LA LIVRAISON



OU

À DÉPOSER EN MAGASIN



OU

À DÉPOSER EN DÉCHÈTERIE



Points de collecte sur www.quefairedemesdechets.fr
Privilégiez la réparation ou le don de votre appareil !

Wenn Sie Fragen haben, wenden Sie sich bitte an unser Kundendienstzentrum, Unsere Kontaktdaten stehen unten:

DE

 +49 40 87408465

 service@aosom.de

ADRESSE DES IMPORTEUR/Hersteller/REP:
MH Handel GmbH
Wendenstraße 309
D-20537 Hamburg
Germany
IN CHINA HERGESTELLT

In caso di dubbio, si prega di contattare il nostro centro assistenza clienti, I nostri dettagli di contatto sono di seguito:

IT

 0039-0249471447

 clienti@aosom.it

IMPORTATO DA/Produttore/REP:
AOSOM Italy srl
Centro Direzionale Milanofiori
Strada 1 Palazzo F1
20057 Assago (MI)
P.I.: 08567220960
FATTO IN CINA

Si tiene alguna pregunta, comuníquese con nuestro Centro de Atención al Cliente, Nuestros datos de contacto son los siguientes:

ES

 0034-931294512

 atencioncliente@aosom.es

IMPORTADOR/Fabricante/REP:
SPANISH AOSOM, S.L.
C/ROC GROS, N°15.08550, ELS HOSTALETES DE
BALENYÀ, SPAIN.
B66295775
HECHO EN CHINA

Se tiver alguma dúvida, por favor contacte o nosso Centro de Atendimento ao Cliente, Os nossos dados de contacto são os seguintes:

 0034-931294512

 info@aosom.pt.

IMPORTADOR/Fabricante/REP:
SPANISH AOSOM, S.L.
C.ROC GROS N.15, 08550. ELS HOSTALETES DE
BALENYÀ
FEITO NA CHINA