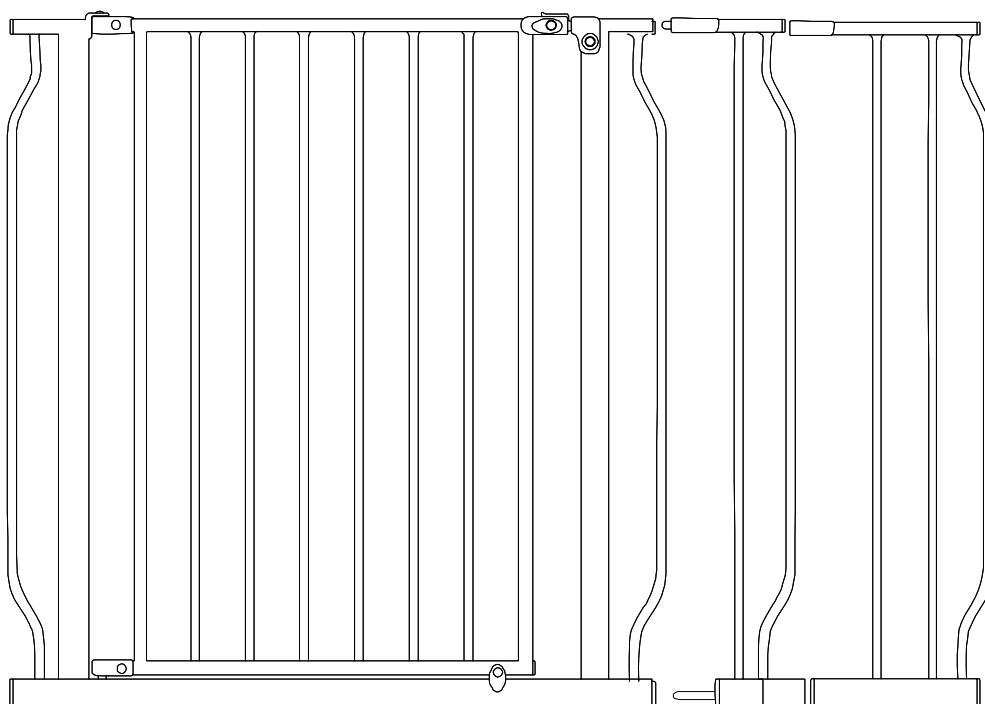

IN240200117V01

**D06-109V01**

**EN\_ IMPORTANT, RETAIN FOR FUTURE REFERENCE: READ CAREFULLY.**

**FR\_ IMPORTANT: A LIRE ATTENTIVEMENT ET À CONSERVER POUR CONSULTATION ULTÉRIEURE.**

**ES\_ IMPORTANTE, LEA Y GUARDE PARA FUTURAS REFERENCIAS.**

**PT\_ IMPORTANTE: LEIA ATENTAMENTE E GUARDE PARA CONSULTA FUTURA.**

**DE\_ WICHTIG! SORGFÄLTIG LESEN UND FÜR SPÄTER NACHSCHLAGEN AUFBEWAHREN.**

**IT\_ IMPORTANTE! CONSERVARE IL PRESENTE MANUALE PER FUTURO RIFERIMENTO E LEGGERLO ATTENTAMENTE.**

**RO\_ IMPORTANT: CITIȚI CU ATENȚIE ȘI PĂSTRAȚI PENTRU CONSULTARE VIITOARE.**

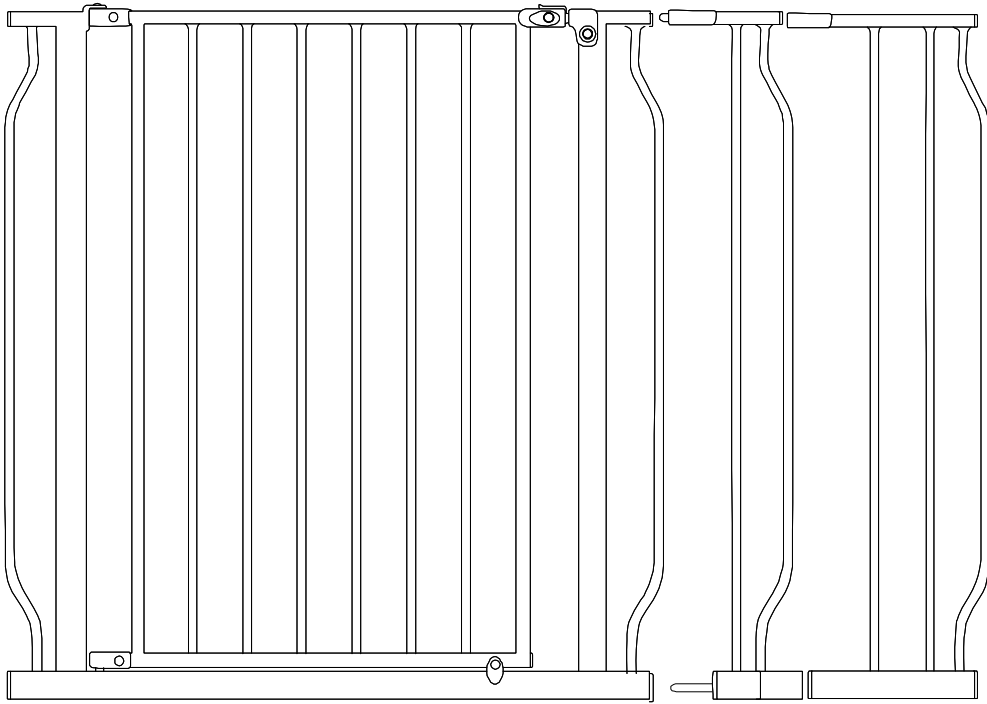

Product & Parts

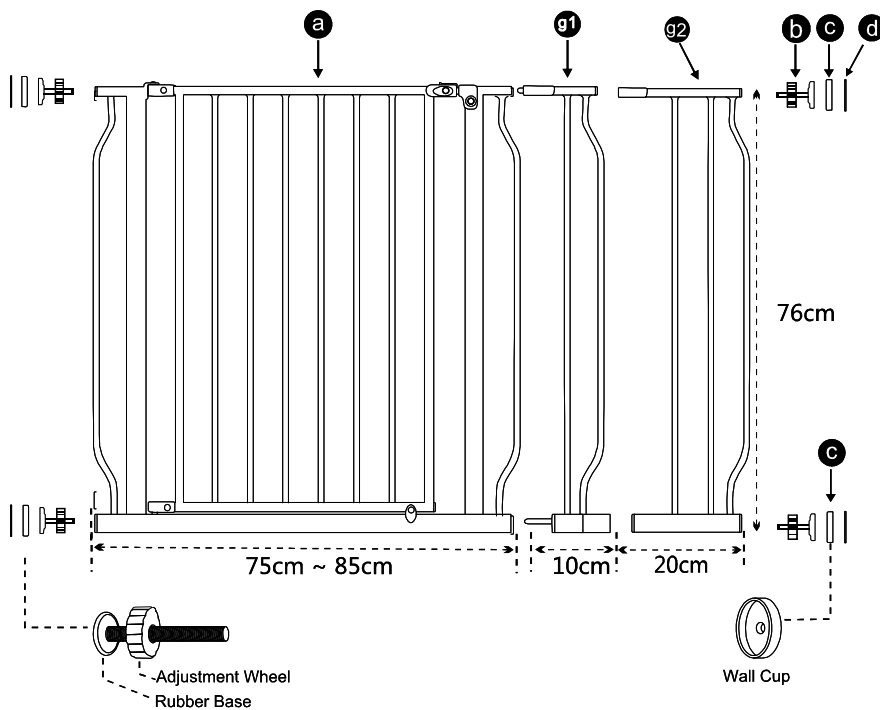

- a** Main Gate x1
- b** Tension Bolt x4
- c** Wall Cup x4
- d** Stick Pad x4
- e** Screw x5
- f** Dry Wall Anchor x5
- g1** 10cm extension
- g2** 20cm extension

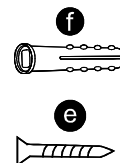

The picture is only for reference, please make the object as the standard.

**WARNING:** This package contains small parts and sharp points in an unassembled state. Keep out of reach of children. Adult assembly required.

**WARNING:**

To help your installation, **Do not cut off the belt** before installation is completed! **The door gap is NOT a defect!** It will be shortened to 0.2cm after installation.



**Notice: screw in Mounting Cups when using gate on stairs**

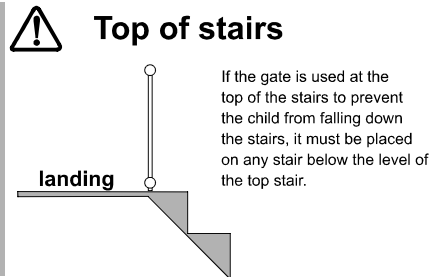
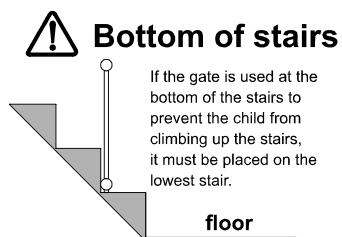

**STEP1.**

Pre-assemble the gate, and locate four points for hole drilling. Hold the wall cup in position and mark the center with a pencil.

**PLEASE NOTE:** The gate should be resting on the floor. **DO NOT** allow a gap of more than 0.5cm between the gate and the floor.

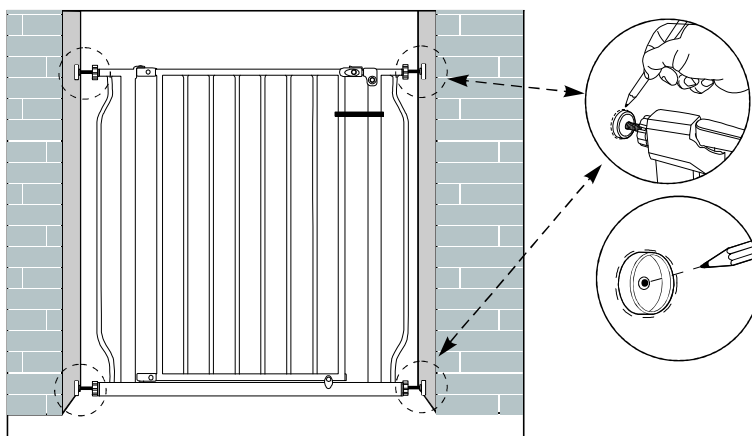
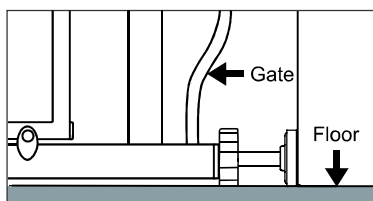

**STEP2.**

Stick pad when using pressure mounted installation. Remove two side of the sticky pad, stick 4 pads to 4 wall cups. Then wall cups cover the bolts.

**TIP:** If you do not have to worry about damaging the walls, skip this step.

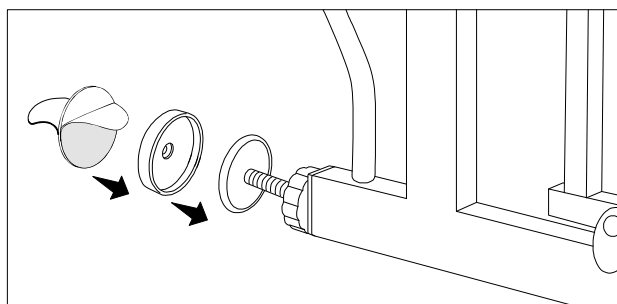

**STEP3.**

Drill hole for the 4 marked positions, then put dry wall anchor(g) and use screw(f) and the wall cup (d)

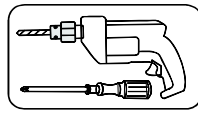
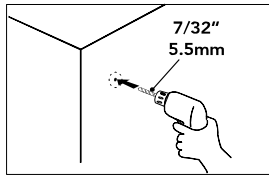

The product does not contain the installation tool

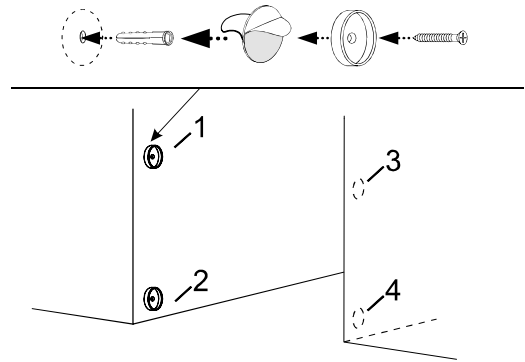

**STEP4.**

Tighten the top of the tension knobs by turning them clockwise at the same time

**Note:** Make sure the bottom of the gate frame remains completely flat on the floor.

Next, tighten the bottom of the tension knobs at the top on the same time by turning them clockwise.

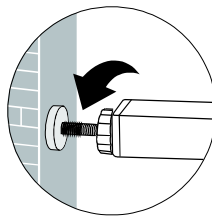

Rotate 4 bolts

Rotate the bolts until the gap about 0.2cm

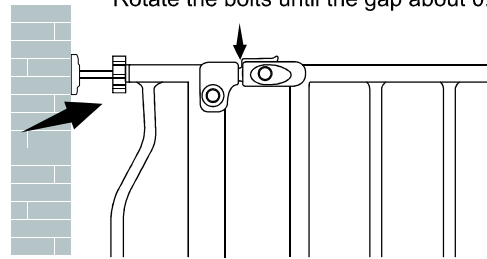

**STEP5.**

Cut off the belt and test the gate:

1. Push the gate to check stability.
2. Open and close the walk through gate

Pull the button to the right, then lift the gate panel UP to open.

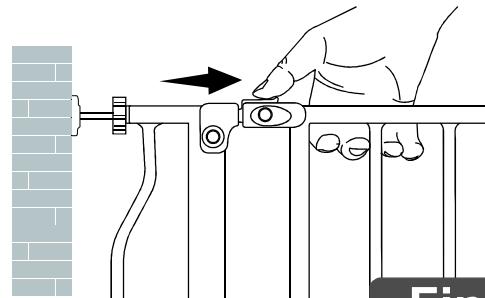

**Finish**

**TROUBLE SHOTING**

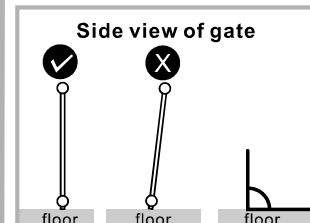
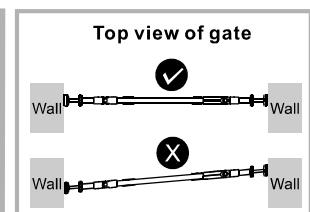
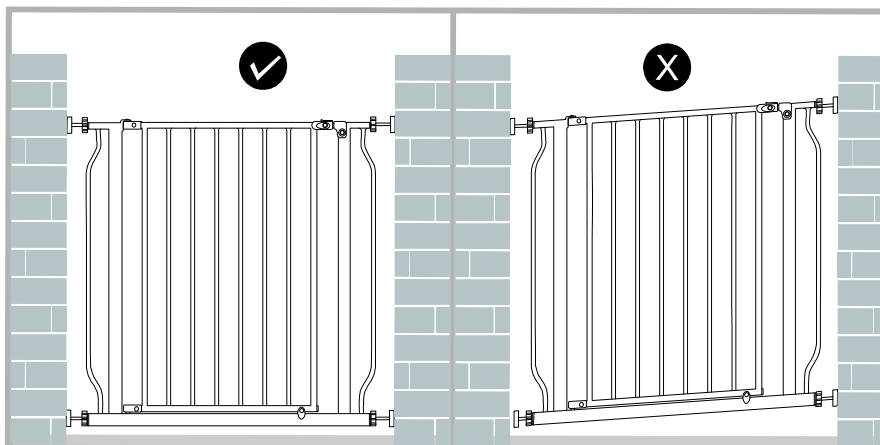

**! WARNING**

- To prevent serious injury or death, securely install gate or enclosure and use according to manufacturer's instructions.
- Use only with the locking mechanism securely engaged
- Stop using gate if any parts are missing or become damaged.
- ALWAYS install and use gates as directed using all required parts.
- Periodically check all fasteners to be sure they are tight and secure.
- Adult Assembly Required.
- The surfaces that the gate is to fixed to must be suitable for the purpose and must be structurally sound.
- Indoor use only , is not to be exposed to outdoor elements.
- Install this gate away from heaters and other sources of heat.

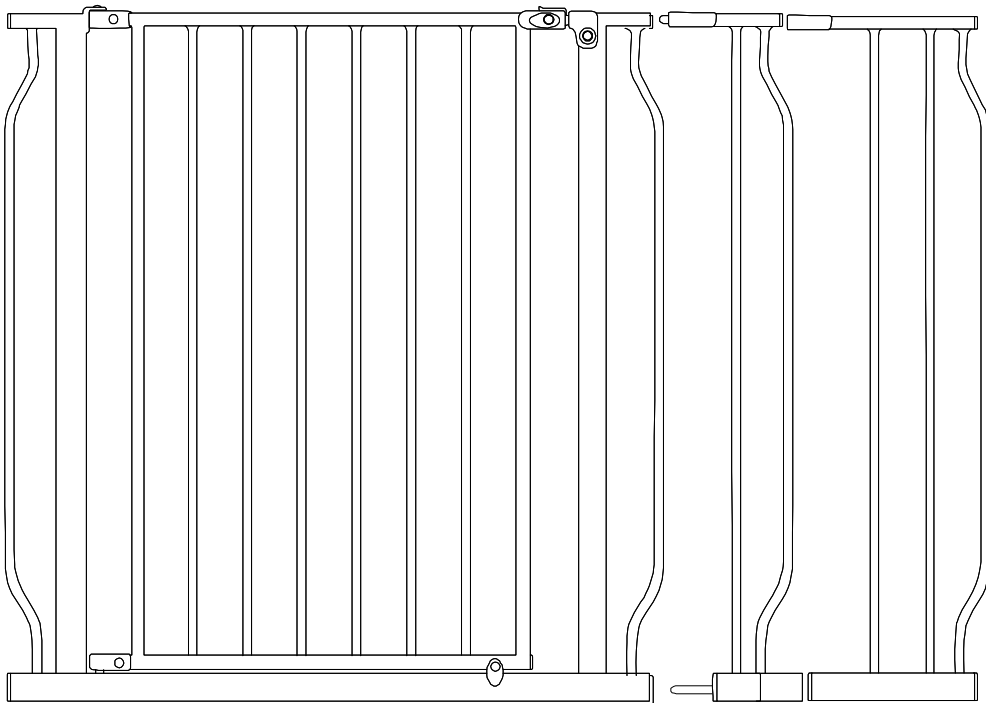

### Produits et Pièces

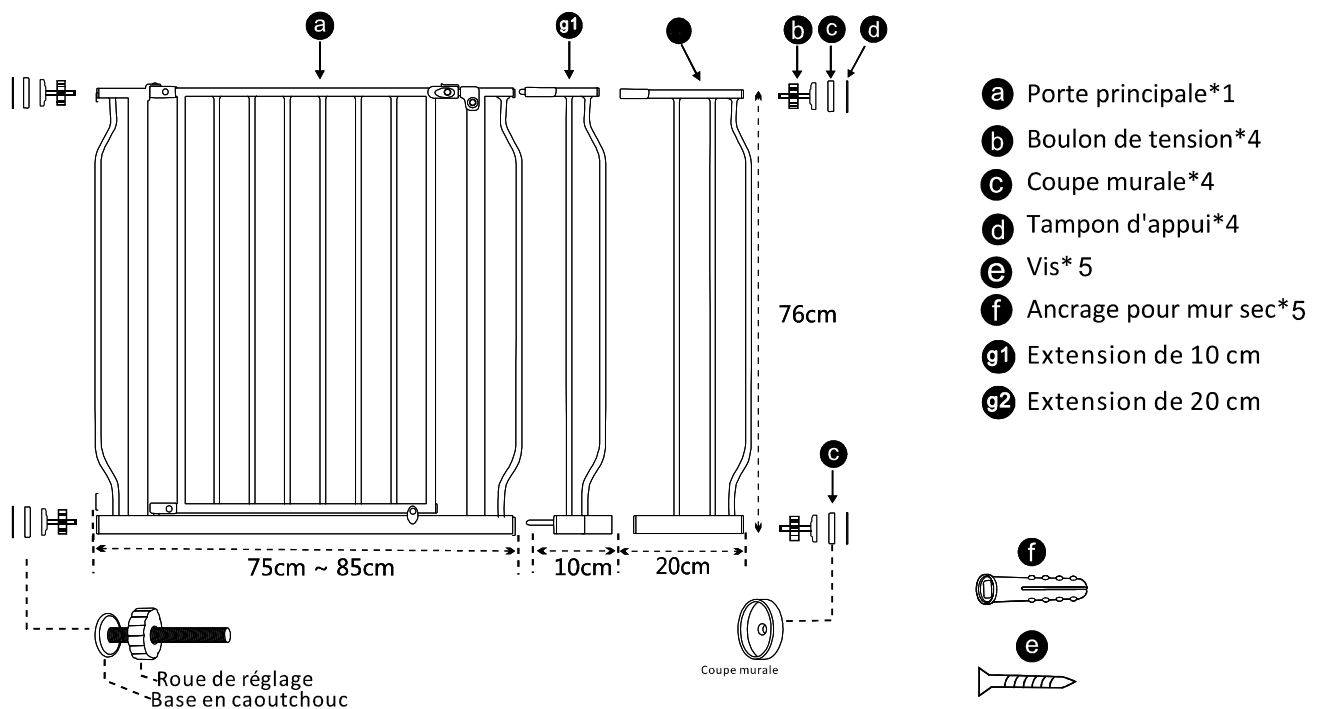

L'image est fournie à titre de référence uniquement, veuillez vous conférer à l'objet en tant que norme.



**AVERTISSEMENT :** Cet emballage contient de petites pièces et des pointes acérées dans son état non assemblé. Tenir hors de portée des enfants. L'assemblage doit être effectué par un adulte.

**Avertissement :**  
 Pour faciliter votre installation, ne coupez pas la courroie avant la fin de l'installation ! L'écart de la porte n'est PAS un problème ! Il sera réduit à 0,2 cm après l'installation.

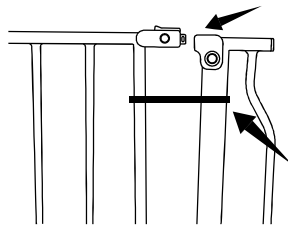

L'écart entre les portes n'est PAS un problème ! Après l'installation, il sera réduit à 0,2 cm.



**NE PAS COUPER LA COURROIE**  
 Avant la fin de l'installation



**Remarque : Vissez les coupelles de montage lorsque vous utilisez la barrière dans des escaliers.**



#### Bas de l'escalier

Si la barrière est utilisée au bas d'un escalier pour empêcher l'enfant de monter, elle doit être installée sur la marche la plus basse.  
 Plancher

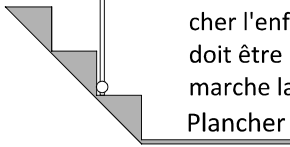

#### Haut de l'escalier

Si la barrière est utilisée en haut de l'escalier pour empêcher l'enfant de tomber dans l'escalier au-dessous du niveau de la marche supérieure.  
 palier

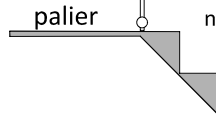

### ÉTAPE 1.

Pré-assemblez la barrière et repérez quatre points pour le perçage des trous. Maintenez la coupe murale en position et marquez le centre avec un crayon.

REMARQUE : la barrière doit reposer sur le sol. NE laissez PAS un espace de plus de 0,5 cm entre la barrière et le sol.

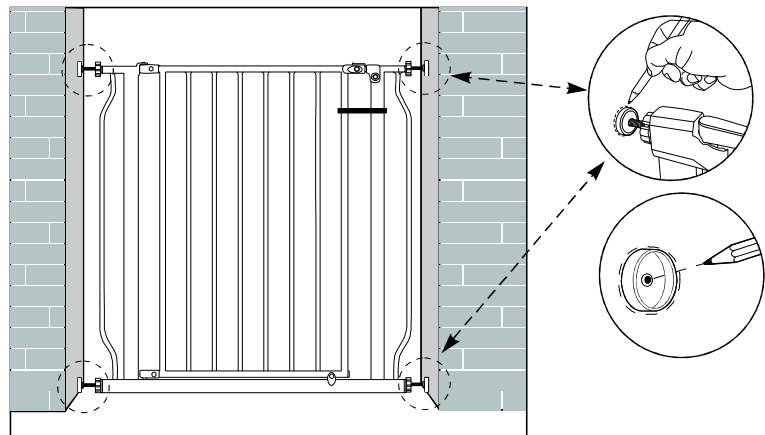
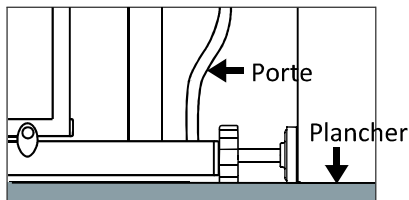

### ÉTAPE 2.

Collez le tampon si vous utilisez une installation à pression. Retirez les deux côtés du tampon adhésif et collez 4 tampons sur 4 supports muraux. Les supports muraux recouvrent ensuite les boulons.

CONSEIL : si vous ne craignez pas d'endommager les murs, passez cette étape.

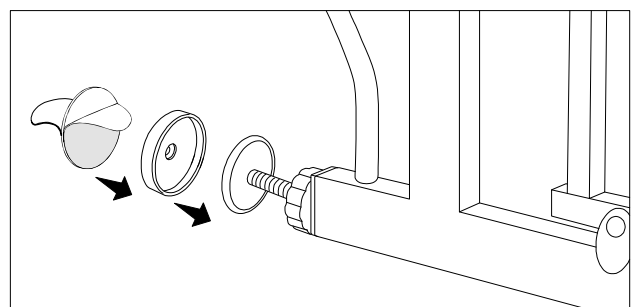

### ÉTAPE 3.

Percez un trou aux 4 emplacements marqués, puis placez la cheville pour cloison sèche (g) et utilisez la vis (f) et la coupelle murale (d).

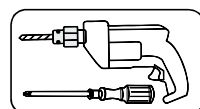
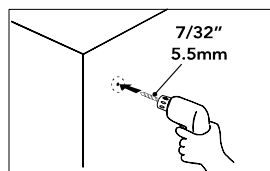

L'outil d'installation n'est pas fourni avec le produit.

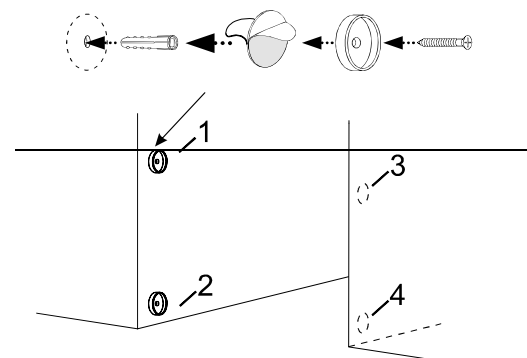

## ÉTAPE 4.

Serrez le haut des boutons de tension en les tournant en même temps dans le sens des aiguilles d'une montre.

Remarque : Assurez-vous que le bas du cadre de la barrière reste complètement plat sur le sol.

Ensuite, serrez simultanément les boutons de tension du bas et du haut en les tournant dans le sens des aiguilles d'une montre.

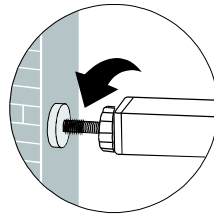

Faites tourner les 4 boulons.

Tournez les boulons jusqu'à ce que l'écart soit d'environ 0,2 cm.

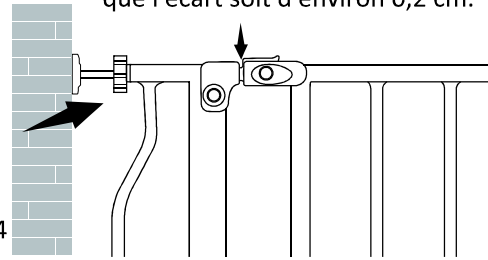

## ÉTAPE 5.

Coupez la courroie et testez la barrière :

1. Poussez la barrière pour vérifier sa stabilité.

2. Ouvrez et fermez la porte de passage

Méthode d'Ouverture :

Tirez le bouton vers la droite, puis soulevez le panneau de la barrière vers le HAUT pour l'ouvrir.

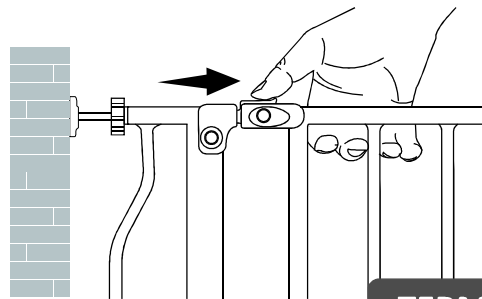

TERMINÉ

## DÉPANNAGE

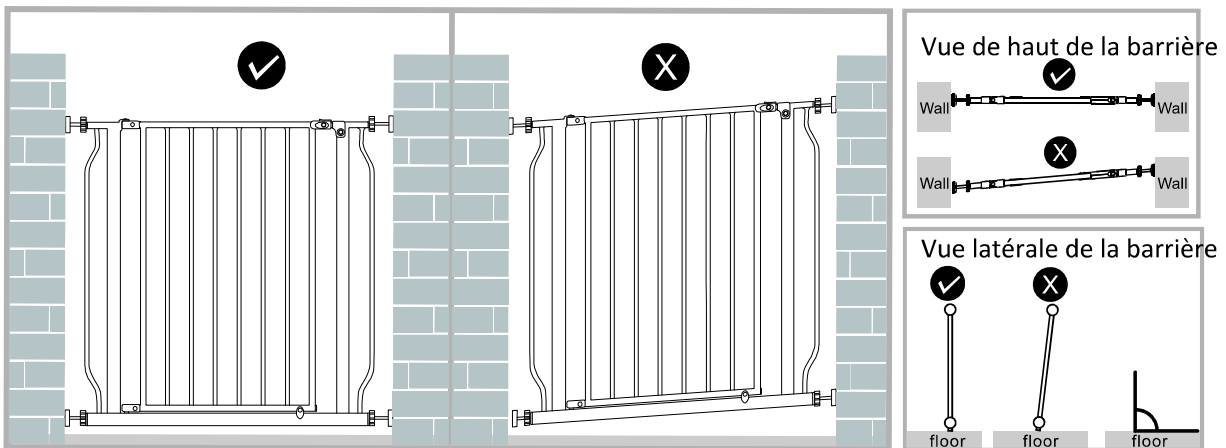

## AVERTISSEMENT

- Pour éviter toute blessure grave ou mortelle, installez solidement la barrière ou l'enceinte et l'utiliser conformément aux instructions du fabricant.
- N'utiliser que si le mécanisme de verrouillage est bien enclenché. Cesser d'utiliser la barrière si des pièces manquent ou sont endommagées.
- TOUJOURS installer et utiliser les barrières conformément aux instructions en utilisant toutes les pièces requises.
- Vérifiez périodiquement toutes les fixations pour vous assurer qu'elles sont bien serrées et sécurisées.
- L'assemblage doit être effectué par un adulte.
- Les surfaces sur lesquelles la barrière doit être fixée doivent convenir à cet usage et être structurellement solides.
- L'installation à l'intérieur uniquement, ne doit pas être exposée aux éléments extérieurs.
- Installez cette barrière loin des chauffages et autres sources de chaleur.

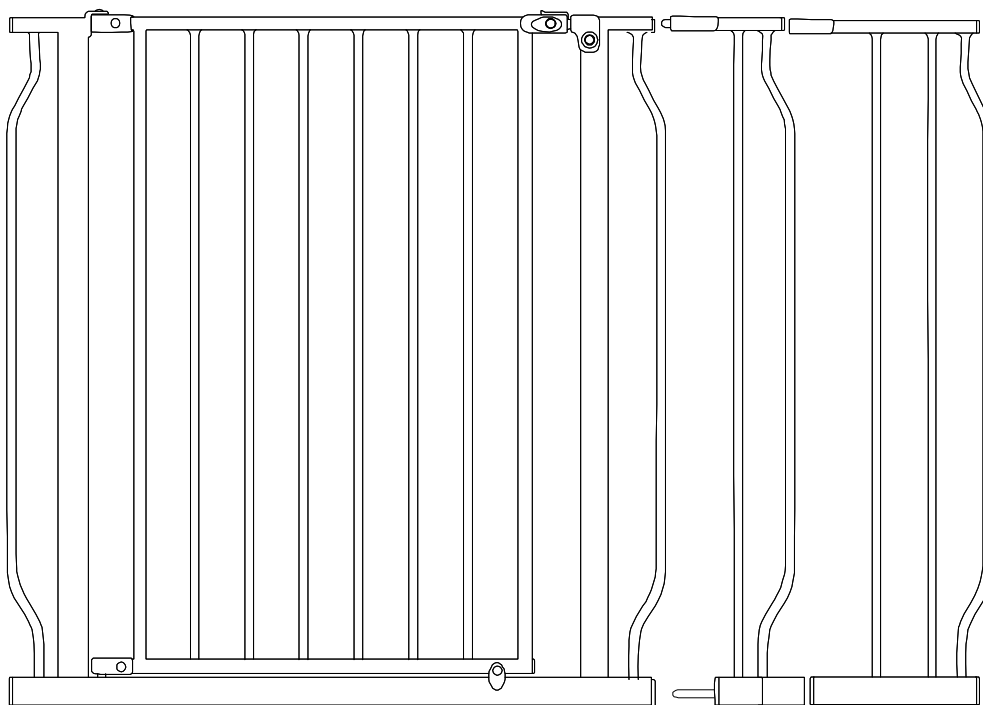

**Producto & Piezas**

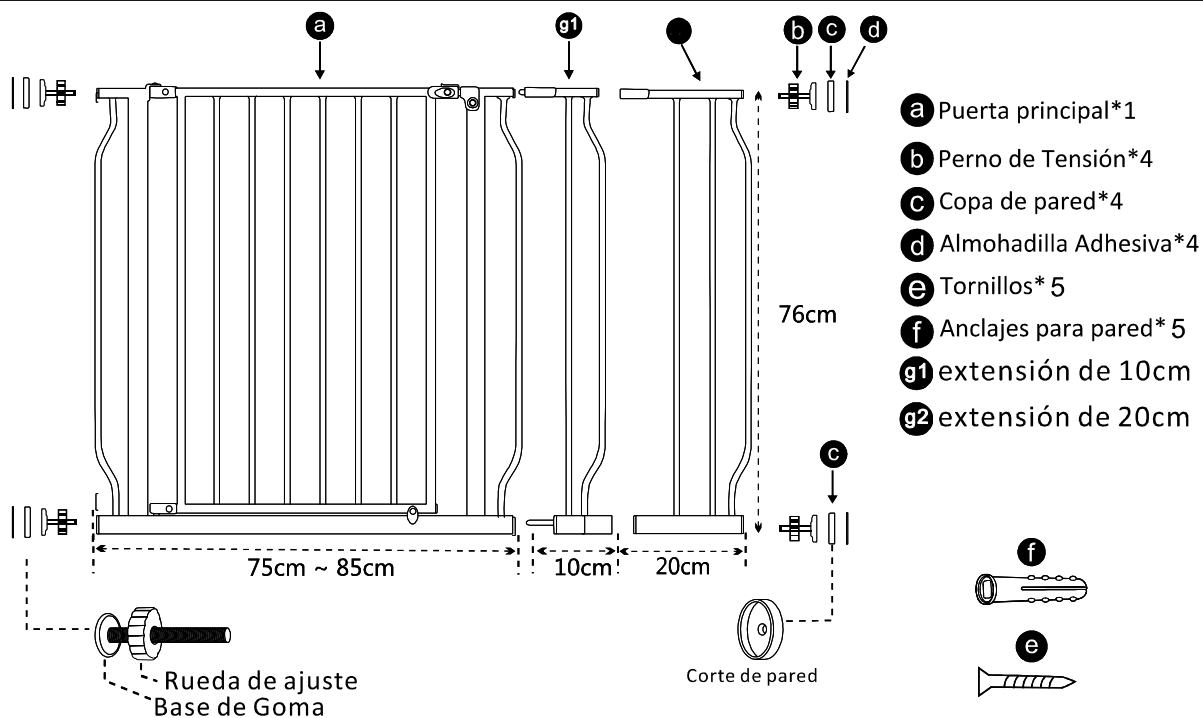

La imagen es sólo como referencia, el producto real puede ser diferente.



**ADVERTENCIA:** Este paquete con **ene** piezas pequeñas y puntas afiladas sin ensamblar. Manténgalo fuera del alcance de los niños. El ensamblaje debe realizarse por un adulto.

**Advertencia:**  
Para facilitar su instalación, ¡no corte la cinta antes de que se complete la instalación! ¡La brecha de la puerta NO es un defecto! Se disminuirá a 0,2 cm después de la instalación.

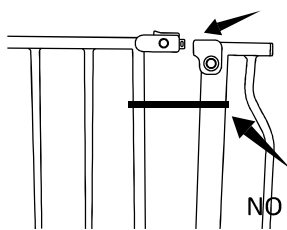

La brecha de la puerta NO es un defecto, se disminuirá a 0,2 cm después de la instalación.



**NO CORTE LA CINTA**  
antes de que se complete la instalación.

**Nota:** Atornille las copas de montaje cuando se **u** liza la puerta en las escaleras.



**Parte inferior de escaleras**

Si la puerta se usa para evitar que el niño suba las escaleras, se debe colocar en la escalera más baja.

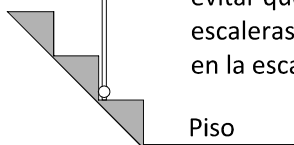

**Parte superior de escaleras**

Si la puerta se usa para evitar que el niño se caiga por las escaleras, se debe colocar debajo la escalera superior.

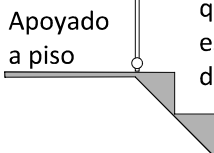

**PASO 1.**

Pre-ensamble la puerta y determine los cuatro puntos para la perforación. Sostenga la copa de pared en su posición y marque el centro con un lápiz.

**POR FAVOR TENGA EN CUENTA:** La puerta debe estar apoyada en el piso. El espacio entre la puerta y el piso no debe ser más de 0,5 cm.

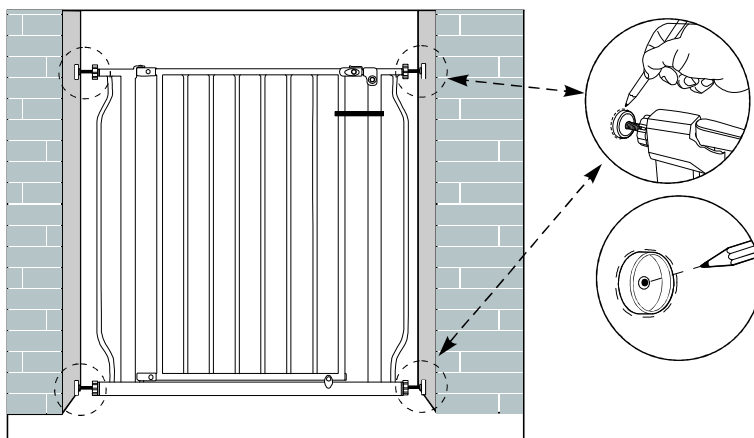
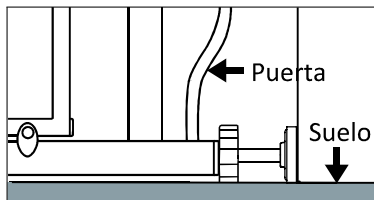

**PASO 2.**

Ulice la almohadilla adhesiva cuando se realiza la instalación por presión. Quite los papeles protectores de las almohadillas adhesivas, y péguelas en las copas de pared.

Luego cubre las copas de pared en los pernos.  
**SUGERENCIA:** Puede omitir este paso si no tiene preocupaciones sobre los daños de la pared.

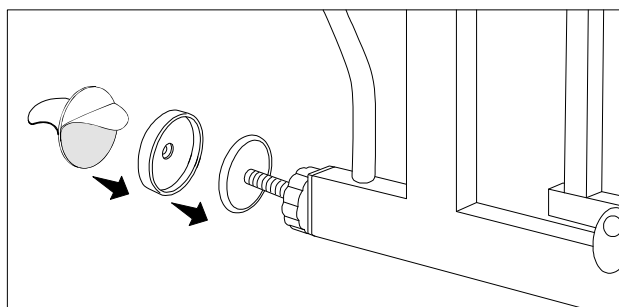

**PASO 3.**

Taladre orificios las 4 posiciones marcadas, luego coloque el anclaje para pared seca (g), el tornillo (f) y la copa de pared (d).

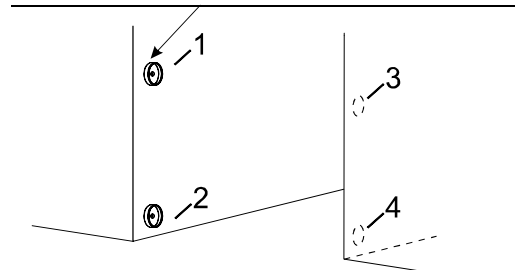
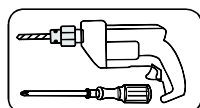
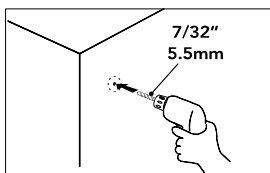

Este producto no con  
herramientas de montaje. ene

## PASO 4.

PASO 6. Apriete la parte superior con las perillas de tensión girándolas en el sentido horario al mismo tiempo.

Nota: Asegúrese de que la parte inferior de la puerta permanezca completamente apoyada sobre el piso.

Luego, apriete la parte inferior con las perillas de tensión en la parte superior al mismo tiempo girándolas en el sentido horario.

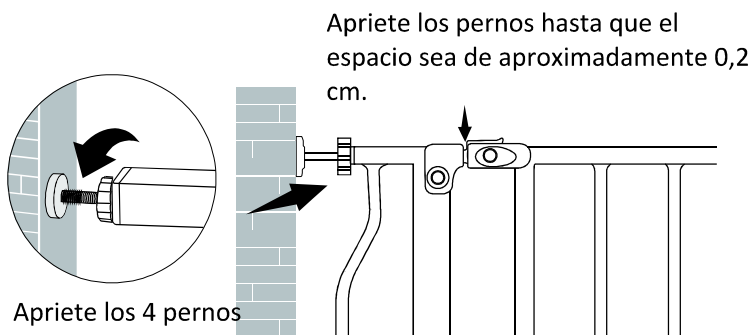

## PASO 5.

Corte la cinta y inspeccione la puerta:

1. Empuje la puerta para comprobar su estabilidad.

2. Abra y cierre la puerta de paso.

Método de abrir la puerta de paso:

Tire del botón hacia la derecha, luego levante el panel de la puerta HACIA ARRIBA para abrirla.

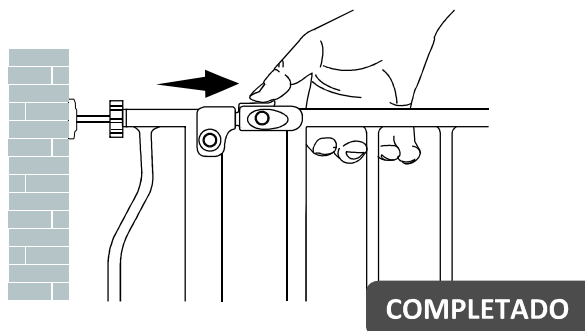

## SOLUCIÓN DE PROBLEMAS

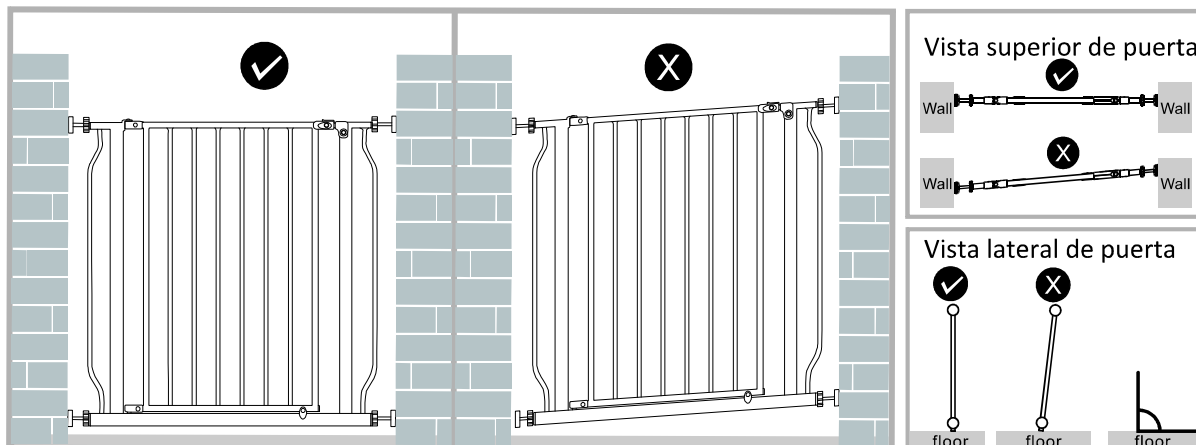

## ADVERTENCIA

- Para evitar lesiones graves o la muerte, instale la puerta o el gabinete de forma segura y úselo de acuerdo con las instrucciones del fabricante.
- Utilice el producto con el mecanismo de bloqueo seguramente enganchado. No utilice la puerta si falta alguna pieza o está dañada.
- SIEMPRE instale y use las puertas como se indica con todas las piezas ensambladas.
- Periódicamente revise todos los sujetadores para asegurarse de que estén apretados y seguros.
- El ensamblaje debe realizarse por adulto.
- Las superficies a las que se fijará la puerta deben ser adecuadas para el propósito y deben ser estructuralmente sólidas.
- Sólo para uso en interiores, no debe exponerse a ambientes exteriores.
- Instale esta puerta lejos de calentadores y otras fuentes de calor.

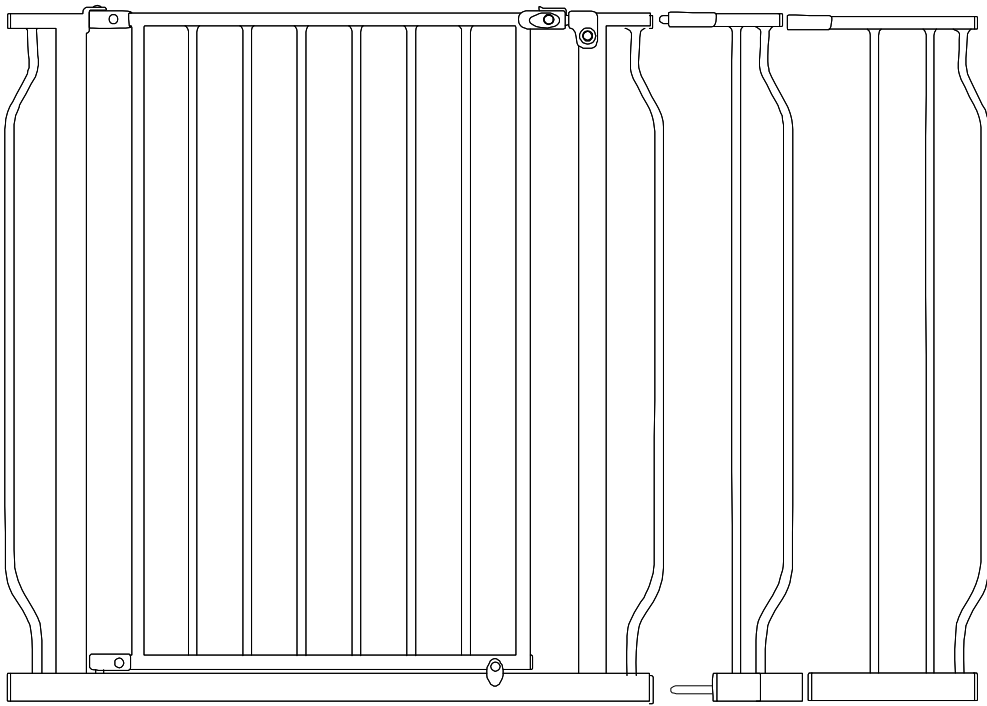

### Produkt & Teile

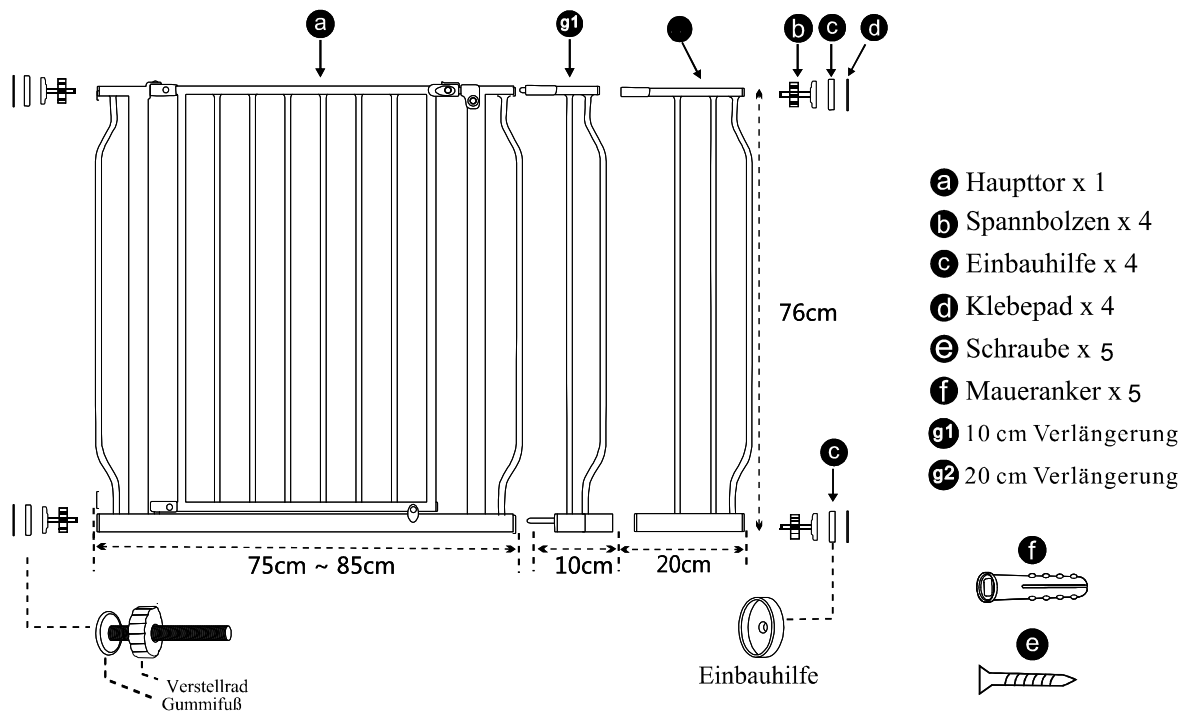

Das Bild dient nur als Referenz, bitte legen Sie das Objekt als Standard an.



**WARNUNG:** Dieses Paket enthält Kleinteile und scharfe Spitzen in einem unmontierten Zustand. Außerhalb der Reichweite von Kindern aufbewahren. Montage durch einen Erwachsenen erforderlich.

**Warnung:**  
Um die Installation zu erleichtern, schneiden Sie den Riemen nicht ab, bevor die Installation abgeschlossen ist!  
Der Türspalt ist KEIN Defekt!  
Er wird nach der Installation auf 0,2 cm verkürzt.

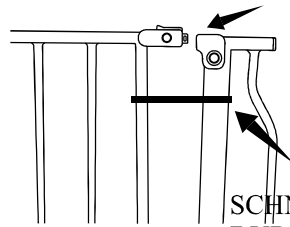

Der Türspalt ist KEIN Defekt!  
Nach der Installation wird er auf 0,2 cm verkürzt sein



**SCHNEIDEN SIE DEN RIEMEN NICHT DURCH** Vor Abschluss der Installation

**! Hinweis: Schrauben Sie bei Verwendung des Tores auf einer Treppe die Einbauhilfen ein**

**! Unterseite der Treppe**  
Wird das Tor am unteren Ende der Treppe verwendet, um zu verhindern, dass das Kind die Treppe hochklettert, muss es auf der untersten Stufe angebracht werden.  
Boden

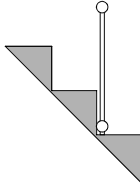

**! Oberseite der Treppe**  
Wenn das Tor am oberen Ende der Treppe verwendet wird, um zu verhindern, dass das Kind die Treppe unterhalb der obersten Stufe hinunterfällt  
Treppenabsatz

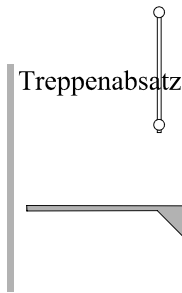

**SCHRITT 1.**

Montieren Sie das Tor vor und suchen Sie vier Punkte für die Lochbohrung. Halten Sie die Einbauhilfe in Position und markieren Sie die Mitte mit einem Bleistift.  
**BITTE BEACHTEN:** Das Tor sollte auf dem Boden aufliegen. Lassen Sie KEINEN Spalt von mehr als 0,5 cm zwischen dem Tor und dem Boden.

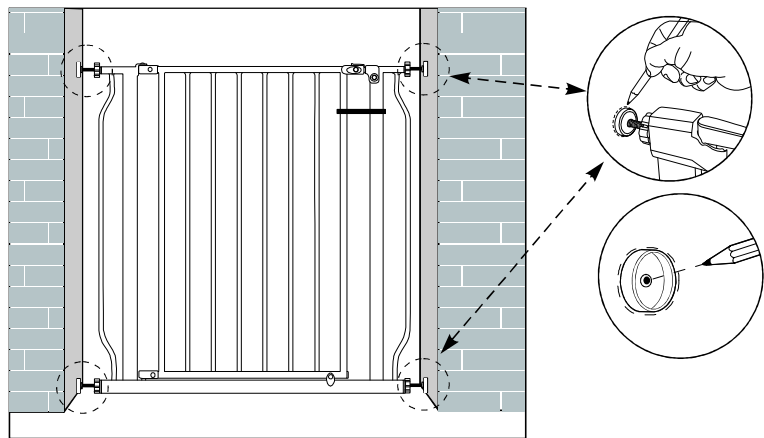
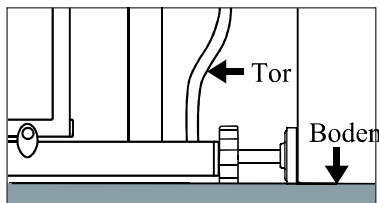

**SCHRITT 2.**

Klebeпад bei druckmontierter Installation. Entfernen Sie zwei Seiten des Klebeпаds, kleben Sie 4 Pads auf 4 Einbauhilfen. Die Einbauhilfen decken dann die Bolzen ab.  
**TIPP:** Wenn Sie nicht befürchten müssen, die Wände zu beschädigen, überspringen Sie diesen Schritt.

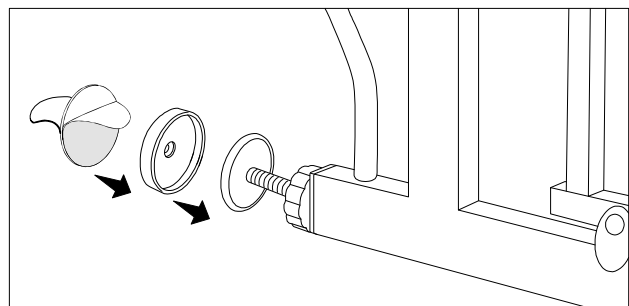

**SCHRITT 3.**

Bohren Sie ein Loch für die 4 markierten Positionen, setzen Sie dann den Maueranker (g) ein und verwenden Sie die Schraube (f) und die Einbauhilfen (d)

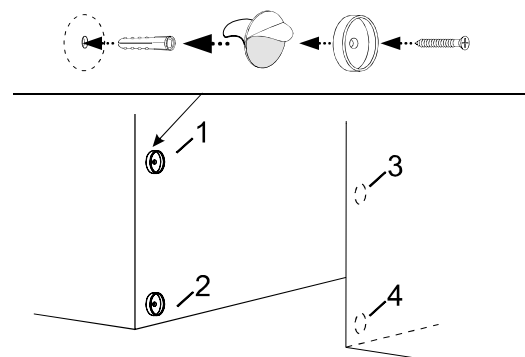
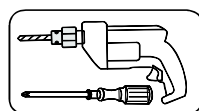
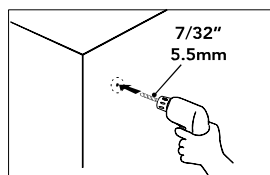

Das Produkt enthält kein Installationswerkzeug

## SCHRITT 4.

SCHRITT 6. Ziehen Sie die Oberseite der Spannknöpfe durch gleichzeitiges Drehen im Uhrzeigersinn fest

Hinweis: Achten Sie darauf, dass die Unterseite des Torrahmens vollständig flach auf dem Boden liegt.

Ziehen Sie anschließend die unteren der Spannknöpfe oben gleichzeitig durch Drehen im Uhrzeigersinn fest.

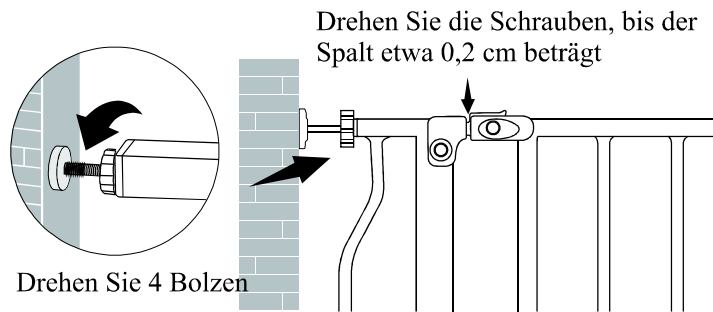

## SCHRITT 5.

Schneiden Sie den Riemen ab und testen Sie das Tor:

1. Schieben Sie das Tor, um die Stabilität zu prüfen.

2. Öffnen und schließen Sie das Durchgangstor

Öffnungsmethode :

Ziehen Sie die Taste nach rechts, dann heben Sie die Torblende zum Öffnen nach oben.

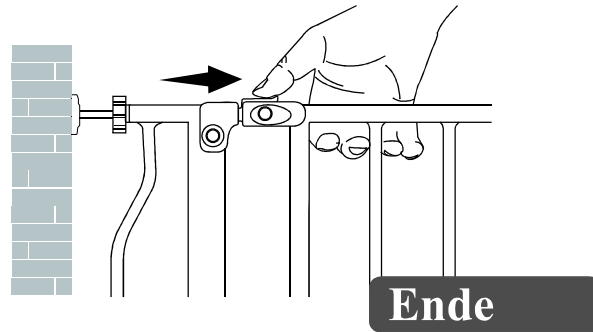

## FEHLERBEHEBUNG

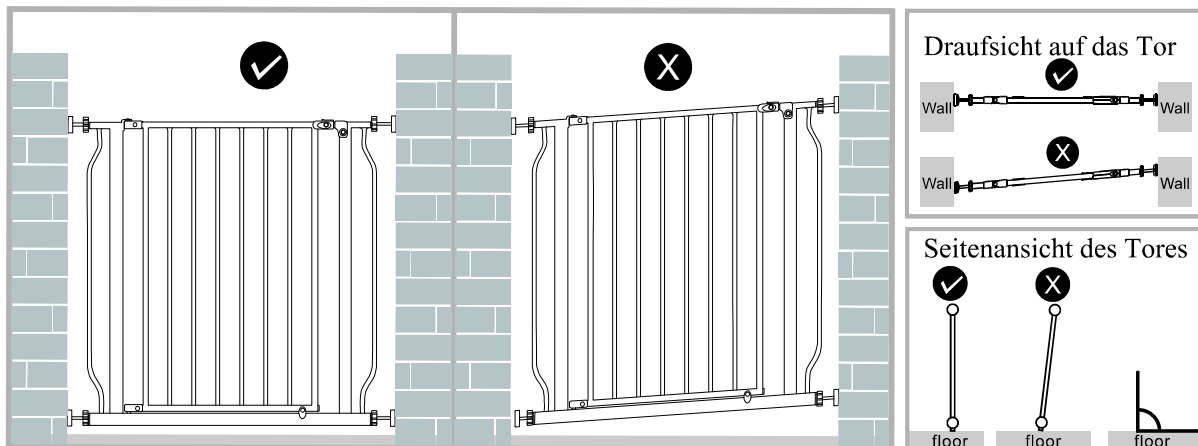
**WARNUNG**

- Um schwere Verletzungen oder Tod zu vermeiden, installieren Sie das Tor oder die Umrandung sicher und verwenden Sie es gemäß den Anweisungen des Herstellers.
- Verwenden Sie das Tor nur, wenn der Verriegelungsmechanismus sicher eingerastet ist. Verwenden Sie das Tor nicht mehr, wenn Teile fehlen oder beschädigt sind.
- Installieren und verwenden Sie das Tor **IMMER** wie vorgeschrieben und verwenden Sie alle erforderlichen Teile.
- Überprüfen Sie regelmäßig alle Befestigungselemente, um sicherzustellen, dass sie fest und sicher sind.
- Montage durch einen Erwachsenen erforderlich.
- Die Oberflächen, an denen das Tor befestigt werden soll, müssen für den Zweck geeignet und statisch einwandfrei sein.
- Das Tor darf nur in Innenräumen verwendet werden und darf nicht den Elementen im Freien ausgesetzt werden.
- Installieren Sie das Tor nicht in der Nähe von Heizungen oder anderen Wärmequellen.

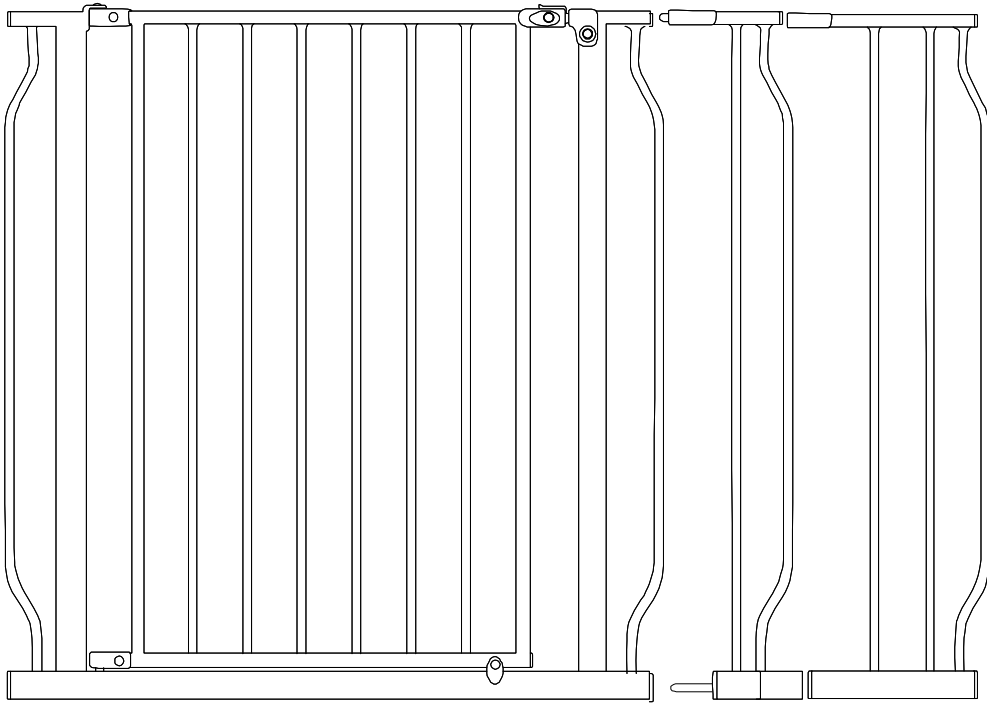

### Prodotto & Parti

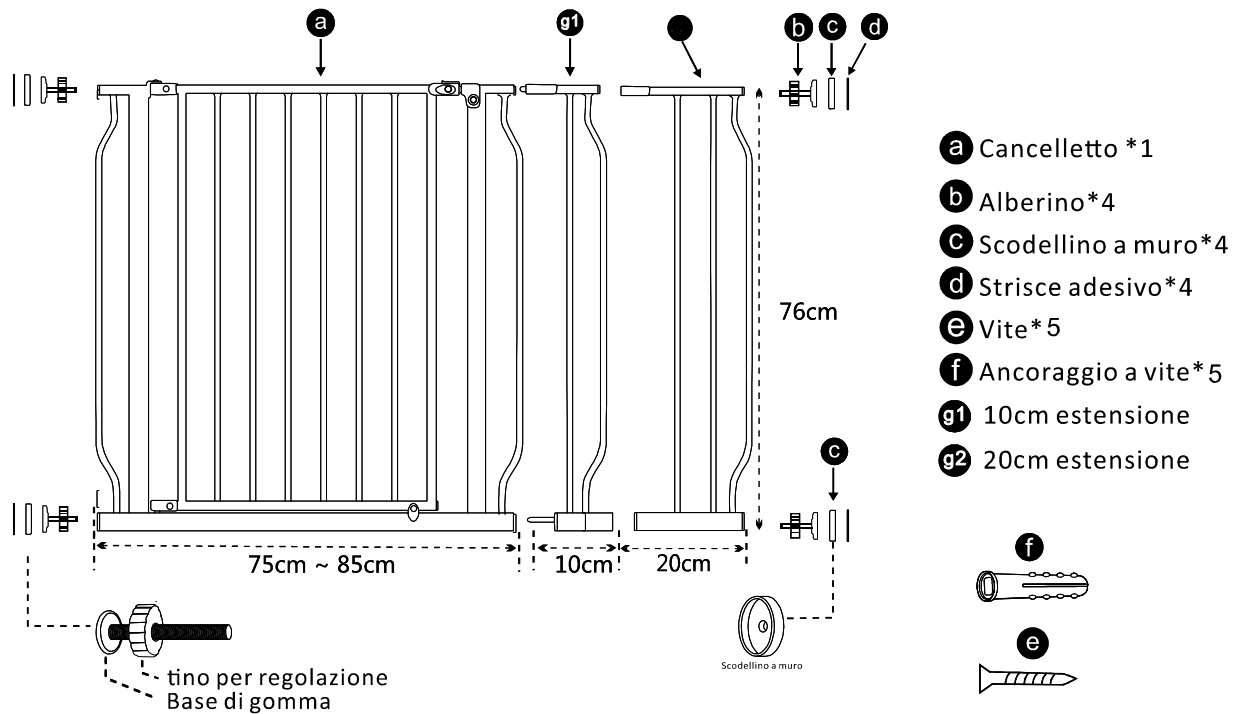

L'immagine è solo per riferimento, si prega di rendere l'oggetto come standard.



**AVVERTENZA:** Questa confezione contiene piccole parti e punte acuminate quando sia in uno stato non assemblato. Tenere fuori dalla portata dei bambini. È richiesto un adulto per il montaggio.

**Avvertenza:**

Per facilitare l'installazione, non tagliare la cintura prima che installazione sia completato!

L'apertura della porta NON è un difetto! Sarà accorciato a 0,2 cm dopo l'installazione.

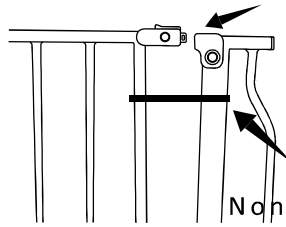

L'apertura della porta NON è un difetto! Sarà accorciato a 0,2 cm dopo l'installazione.



Non tagliare la cintura prima che installazione sia completato!

**Attenzione: Viti vengono usate nelle scodellini a muro quando si utilizza il cancelletto sulle scale.**



Fondo delle scale

Se il cancelletto viene utilizzato in fondo alle scale per impedire al bambino di salire le scale, deve essere posizionato sul gradino più basso.

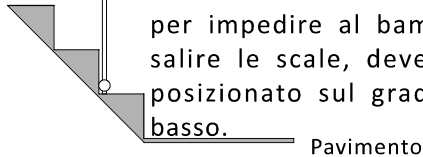

Parte superiore delle scale

Se il cancelletto viene utilizzato alla parte superiore delle scale per evitare che il bambino cada dalle scale al di sotto del livello della scala superiore

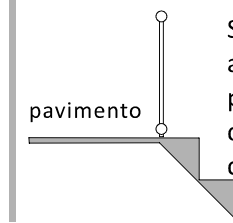
**Fase 1.**

Premontare il cancelletto, e individuare quattro punti per la foratura. Tieni la scodellina da parete in posizione e segna il centro con una matita.

NOTA: Il cancelletto deve essere appoggiato a pavimento. NON lasciare uno spazio superiore a 0,5 cm tra il cancelletto e il pavimento.

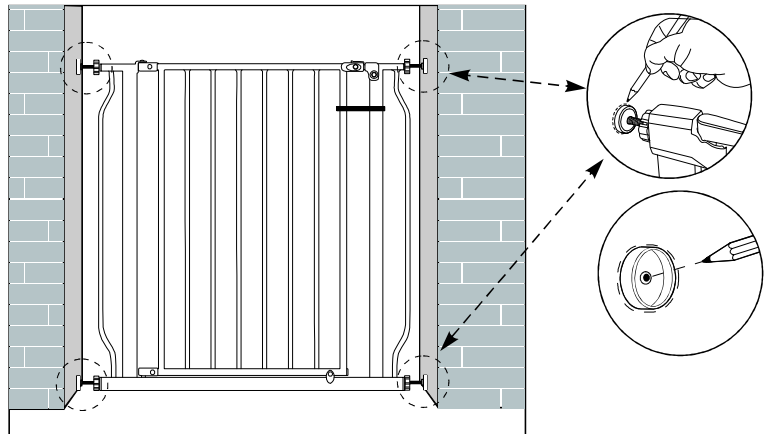
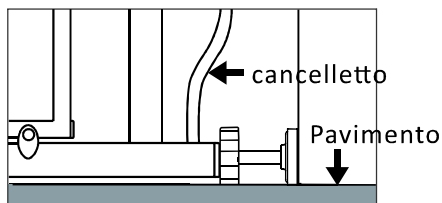
**Fase 2.**

Strisce adesive quando si utilizza l'installazione a pressione. Rimuovere due lati delle strisce adesive, incollare 4 scodellini a muro. Poi utilizzare gli scodellini a muro per coprire gli alberini. SUGGERIMENTO: se ti preoccupi del danneggiamento delle pareti, saltare questa fase.

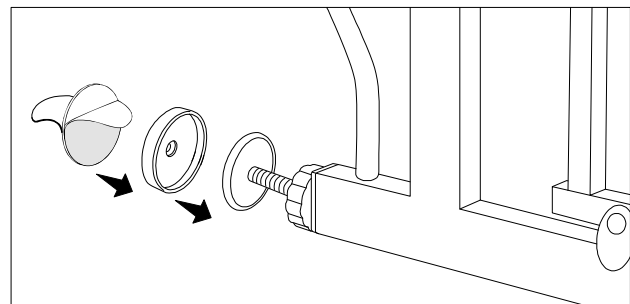
**Fase 3.**

Perforare i fori alle 4 posizioni segnate, e poi inserire l'ancoraggio a vite(g) e utilizzare Vite(f) e lo Scodellino a muro (d)

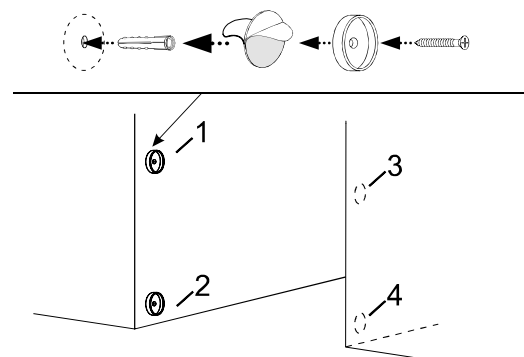
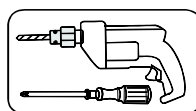
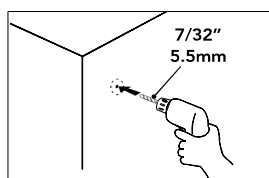

Il prodotto non contiene lo strumento di installazione

## Fase 4.

Fase 6. Stringere la parte superiore dei volantini a tensione ruotandoli contemporaneamente in senso orario

Nota: assicurarsi che il fondo del cancelletto resti completamente piatto sul pavimento.

Poi stringere contemporaneamente la parte inferiore dei volantini a tensione in alto ruotandoli in senso orario.

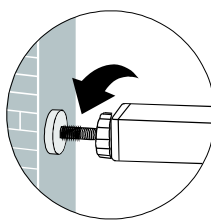

Ruotare 4 alberini

Ruotare gli alberi fino alla distanza di circa 0,2 cm

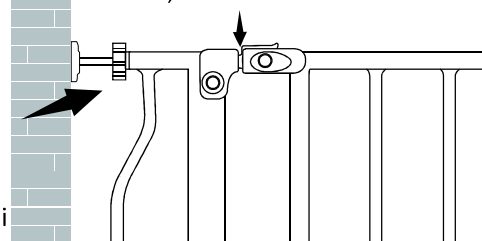

## Fase 5.

Tagliare la cintura e Provare il cancelletto:

1. Spingere il cancelletto per verificarne la stabilità.

2. Aprire e chiudere il cancelletto

Metodo di apertura:

Tirare il tasto verso destra, e sollevare il pannello del cancelletto verso l'alto per aprirlo.

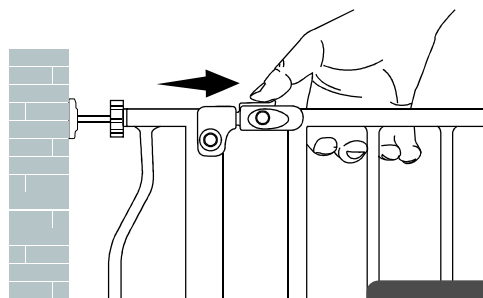

COMPLETATO

## RISOLUZIONE DEI PROBLEMI

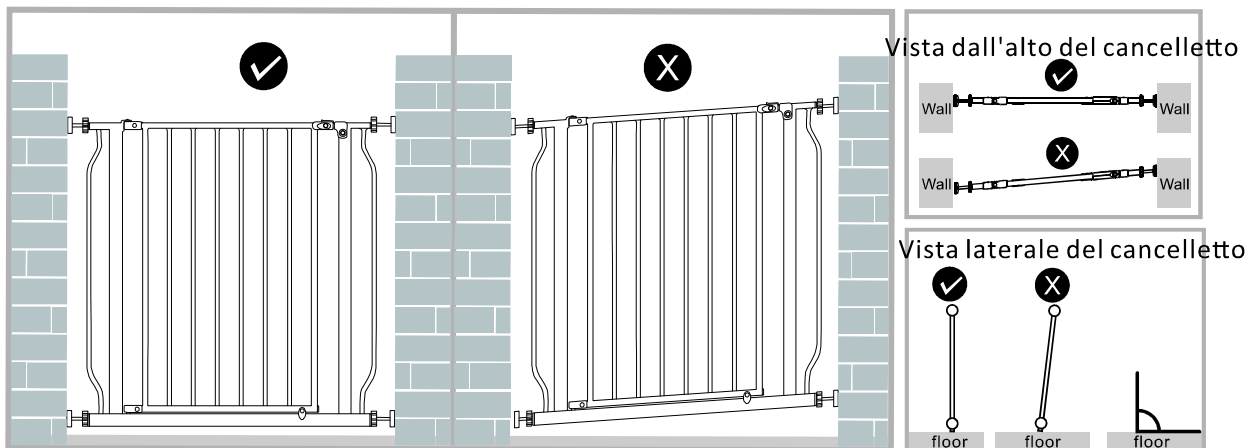

## AVVERTENZA

- Per prevenire lesioni gravi o mortali, installare in modo sicuro il cancelletto o la chiusura e l'utilizzo secondo le istruzioni del produttore.
- Utilizzare solo con il meccanismo di blocco saldamente inserito. Interrompere l'utilizzo di cancelletto se alcune parti sono mancanti o danneggiate.
- Installare e utilizzare SEMPRE il cancelletto come indicato utilizzando tutte le parti richieste.
- Controllare periodicamente tutti i dispositivi di fissaggio per assicurarsi che siano stretti e sicuri.
- Assemblaggio degli adulti richiesto.
- Le superfici su cui si fissa il cancelletto devono essere idonee allo scopo e strutturalmente sane.
- Solo per uso interno, non deve essere esposto a elementi esterni.
- Installare questo cancelletto lontano da riscaldatori e altre fonti di calore

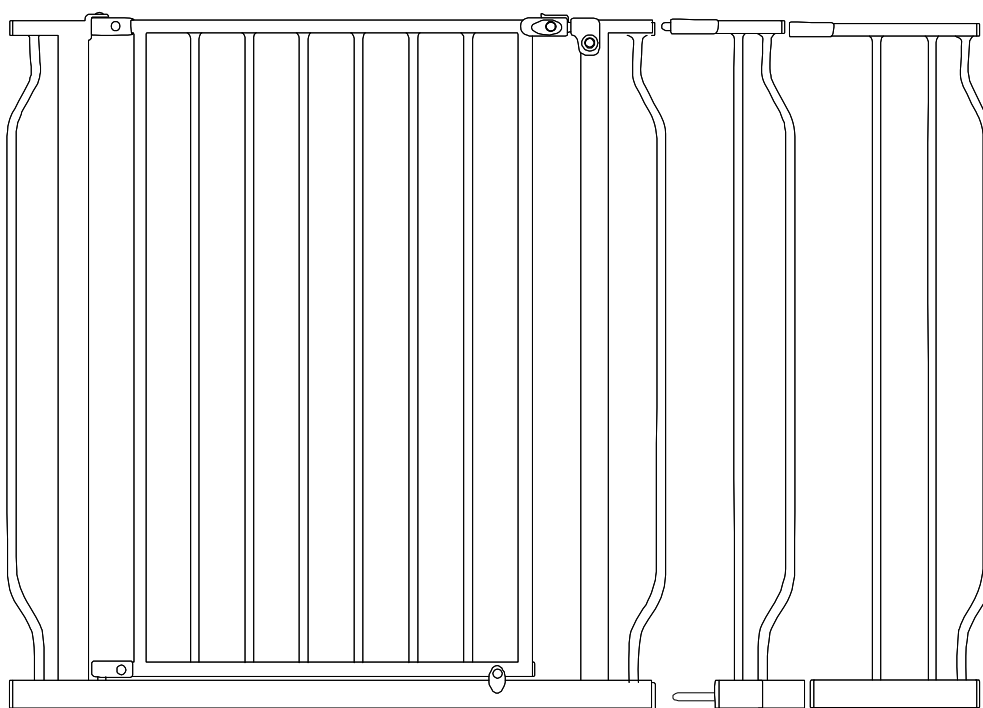

### Produse și piese

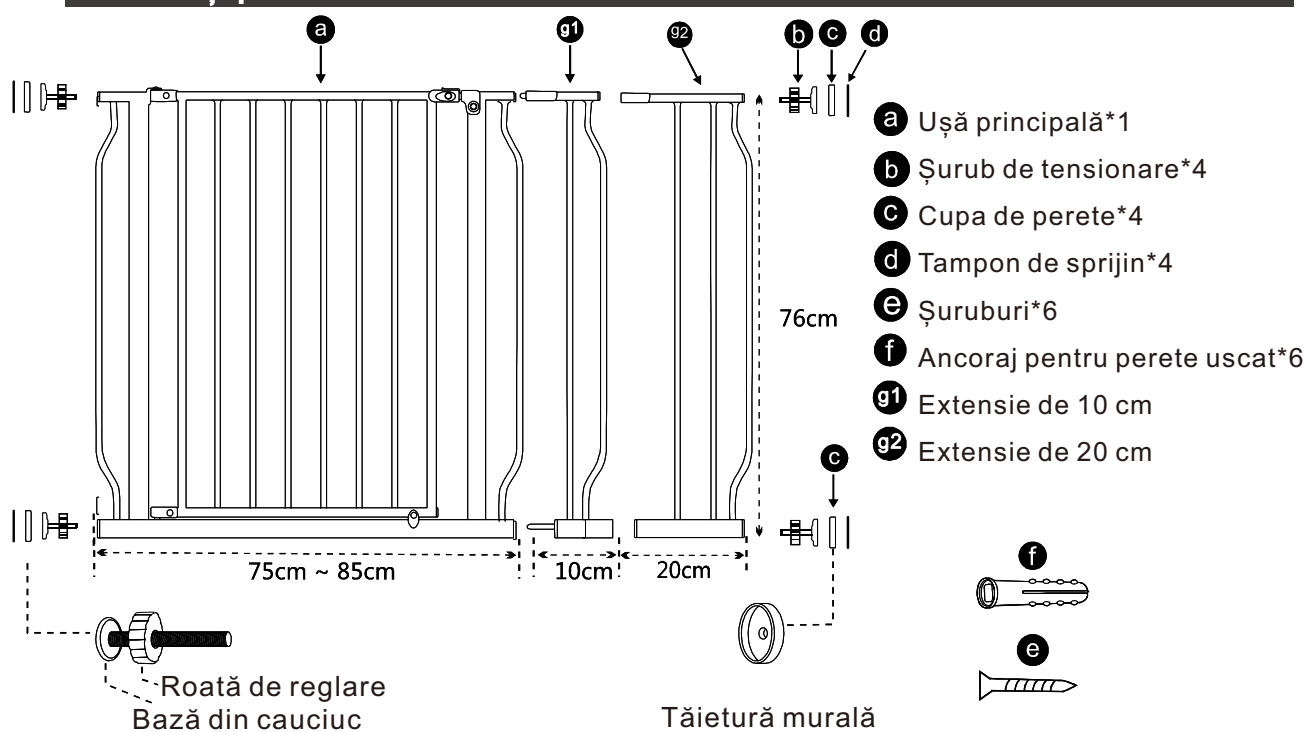

Imaginea este furnizată doar cu titlu informativ, vă rugăm să considerați obiectul ca fiind standard.



**AVERTISMENT:** Acest ambalaj conține piese mici și vârfuri ascuțite în stare neasblată. A nu se lăsa la îndemâna copiilor. Asamblarea trebuie efectuată de un adult.

**Avertisment:**  
Pentru a facilita instalarea, nu tăiați curea înaintea finalizării instalării!  
Decalajul ușii NU reprezintă o problemă! Acesta va fi redus la 0,2 cm după instalare.

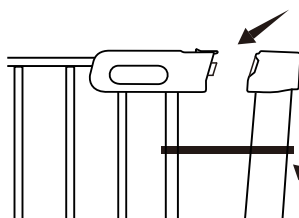

Distanța dintre uși NU este o problemă! După instalare, aceasta va fi redusă la 0,2 cm.



**NU TĂIAȚI CUREAUA**  
Înainte de finalizarea instalării

**Notă: Înșurubați cupele de montare atunci când utilizați bariera pe scări.**



#### Partea de jos a scării

Dacă bariera este utilizată la baza unei scări pentru a împiedica copilul să urce, aceasta trebuie instalată pe treapta cea mai de jos.

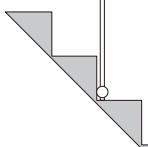

Pardoseală



#### Partea superioară a scării

Dacă bariera este utilizată în partea de sus a scării pentru a împiedica copilul să cadă pe scara de sub nivelul treptei superioare.

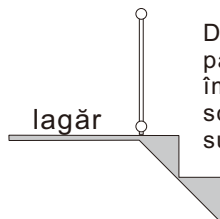

lagăr

#### PASUL 1.

Preasblați bariera și marcați patru puncte pentru găurire. Mențineți tăietura de perete în poziție și marcați centrul cu un creion.

NOTĂ: bariera trebuie să se sprijine pe podea. NU lăsați un spațiu mai mare de 0,5 cm între barieră și podea.

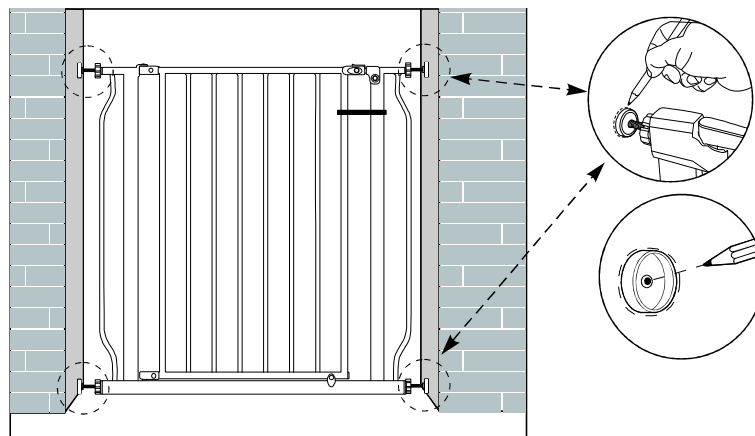
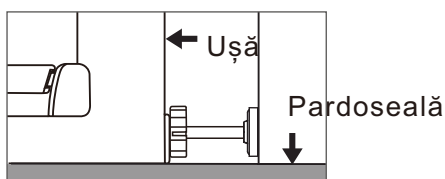

#### PASUL 2.

Lipiți tamponul dacă utilizați un sistem cu presiune. Îndepărtați cele două părți ale tamponului adeziv și lipiți 4 tamponi pe 4 suporturi de perete. Suporturile de perete acoperă apoi șuruburile.

SFAT: dacă nu vă temeți să deteriorați pereții, săriți peste acest pas.

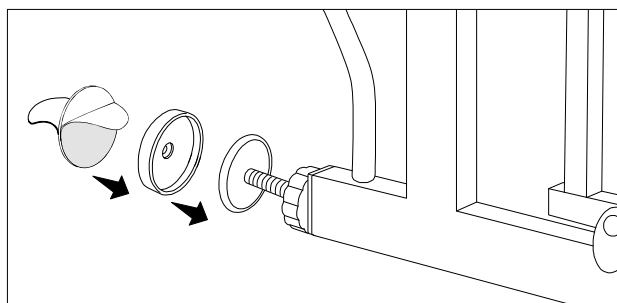

**PASUL 3.**

Faceți o gaură în cele 4 locuri marcate, apoi introduceți diblul pentru gips-carton (g) și utilizați șurubul (f) și capacul de perete (d).

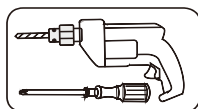
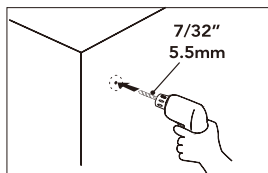

Instrumentul de instalare nu este furnizat împreună cu produsul.

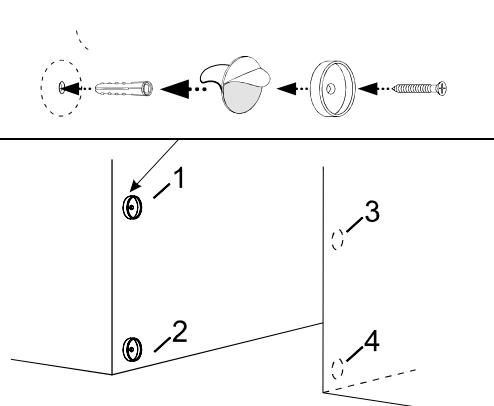

**PASUL 4.** Strângeți partea superioară a butoanelor de tensionare rotindu-le simultan în sensul acelor de ceasornic.

Notă: Asigurați-vă că partea inferioară a cadrului barierei rămâne complet plată pe sol. Apoi, strângeți simultan butoanele de tensionare inferioare și superioare rotindu-le în sensul acelor de ceasornic.

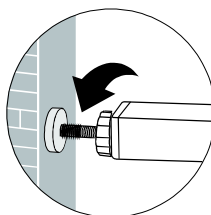

Rotate the bolts until the gap about 0.2cm

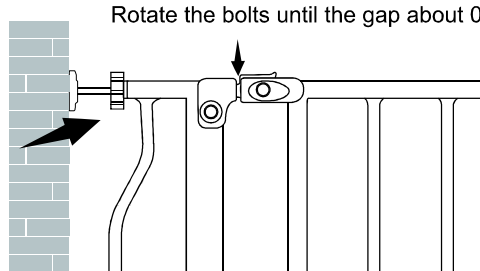

Rotiți cele 4 șuruburi.

**PASUL 5.**

Tăiați cureaua și testați bariera:

1. Împingeți bariera pentru a verifica stabilitatea acesteia.
2. Deschideți și închideți ușa de trecere  
Trageți butonul spre dreapta, apoi ridicați panoul barierei în sus pentru a o deschide.

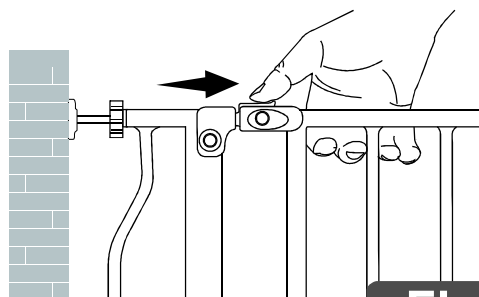

**Finish**

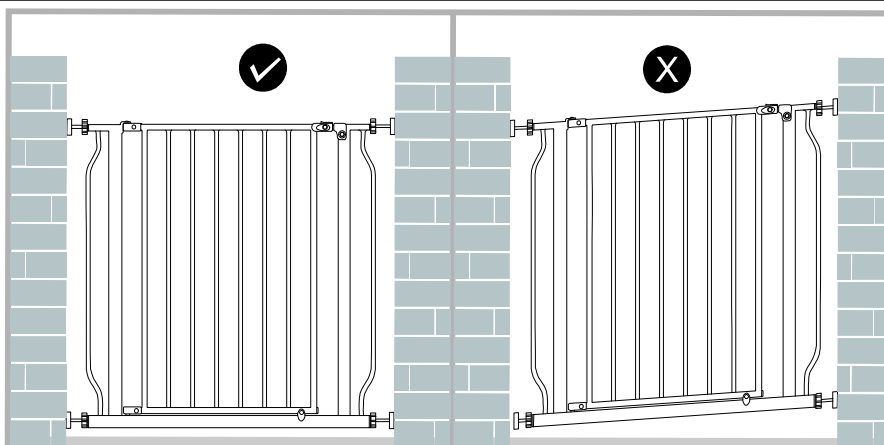
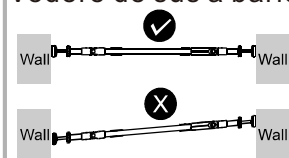
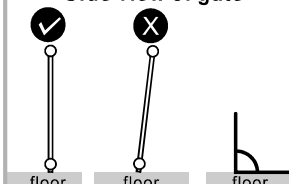
**DEPANARE****Vedere de sus a barierei****Side view of gate**

- Pentru a evita rănilor grave sau mortale, instalați bariera sau împrejmuirea în mod corespunzător și utilizați-o conform instrucțiunilor producătorului.
- Utilizați numai dacă mecanismul de blocare este bine fixat. Nu mai utilizați bariera dacă lipsesc piese sau dacă acestea sunt deteriorate.
- **INSTALAȚI și UTILIZAȚI** întotdeauna barierele conform instrucțiunilor, utilizând toate piesele necesare.
- Verificați periodic toate elementele de fixare pentru a vă asigura că sunt bine strânse și fixate.
- Asamblarea trebuie efectuată de un adult.
- Suprafețele pe care trebuie fixată bariera trebuie să fie adecvate pentru acest scop și să fie solide din punct de vedere structural.
- Utilizați numai în interior, nu trebuie expusă la intemperii.
- Instalați această barieră departe de sisteme de încălzire și alte surse de căldură.

If you have any questions, please contact our customer care center, Our contact details are below:

**US**

 001-877-644-9366

 customerservice@aosom.com

Imported by Aosom LLC  
7777 Center Ave. Suite 430  
Huntington Beach, CA 92647-9998 USA  
MADE IN CHINA

Si tiene alguna pregunta, comuníquese con nuestro Centro de Atención al Cliente, Nuestros datos de contacto son los siguientes:

**ES**

 0034-931294512

 atencioncliente@aosom.es

IMPORTADOR/Fabricante/REP:  
SPANISH AOSOM, S.L.  
C/ROC GROS,Nº15.08550, ELS HOSTALETES DE  
BALENYÀ, SPAIN.  
B66295775  
HECHO EN CHINA

Se tiver alguma dúvida, por favor contacte o nosso Centro de Atendimento ao Cliente, Os nossos dados de contacto são os seguintes:

 0034-931294512

 info@aosom.pt.

IMPORTADOR/Fabricante/REP:  
SPANISH AOSOM, S.L.  
C.ROC GROS N.15, 08550. ELS HOSTALETES DE  
BALENYÀ  
FEITO NA CHINA

If you have any questions, please contact our customer care center, Our contact details are below:

**CA**

 416-792-6088

 customerservice@aosom.ca

Imported by Aosom Canada Inc.  
7270 Woodbine Avenue, Unit 307, Markham,  
Ontario Canada L3R 4B9  
MADE IN CHINA

Si vous avez la moindre question, veuillez contacter notre centre d'assistance à la clientèle, Nos coordonnées sont les suivantes:

 416-792-6088

 customerservice@aosom.ca

Importé par Aosom Canada Inc.  
7270 Woodbine Avenue, unité 307,  
Markham, Ontario Canada L3R 4B9  
FABRIQUÉ EN CHINE

In caso di dubbio, si prega di contattare il nostro centro assistenza clienti, I nostri dettagli di contatto sono di seguito:

**IT**

 0039-0249471447

 clienti@aosom.it

IMPORTATO DA/Produttore/REP:  
AOSOM Italy srl  
Centro Direzionale Milanofiori  
Strada 1 Palazzo F1  
20057 Assago (MI)  
P.I.: 08567220960  
FATTO IN CINA

If you have any questions, please contact our customer care center, Our contact details are below:

**UK**

 0044-800-240-4004

 enquiries@mhstar.co.uk

IMPORTER ADDRESS:  
MH STAR UK Ltd  
1 Northampton Cross Logistics Park  
Northampton Cross Road  
Northampton  
NN4 9FH  
MADE IN CHINA

Wenn Sie Fragen haben, wenden Sie sich bitte an unser Kundendienstzentrum, Unsere Kontaktdaten stehen unten:

**DE**

 0049-0(40)-87408465

 service@aosom.de

ADRESSE DES IMPORTEURE/Hersteller/REP:  
MH Handel GmbH  
Wendenstraße 309  
D-20537 Hamburg  
Germany  
IN CHINA HERGESTELLT

Si vous avez la moindre question, veuillez contacter notre centre d'assistance à la clientèle, Nos coordonnées sont les suivantes:

**FR**

 0033-1-84166106

 aosom@mhfrance.fr

Importé par/Fabricant/REP:  
MH FRANCE  
2 Rue Maurice Hartmann  
92130 Issy Les Moulineaux  
France  
FABRIQUÉ EN CHINE



FR

**DONNEZ  
OU  
RECYCLEZ**



ASSOCIATION

OU



LIVRAISON

OU



DÉCHÈTERIE

Adresses sur [quefairedemesdechets.fr](http://quefairedemesdechets.fr)