

**EN\_ IMPORTANT, RETAIN FOR FUTURE REFERENCE: READ CAREFULLY.**

**FR\_ IMPORTANT: A LIRE ATTENTIVEMENT ET À CONSERVER POUR CONSULTATION ULTÉRIEURE.**

**ES\_ IMPORTANTE, LEA Y GUARDE PARA FUTURAS REFERENCIAS.**

**PT\_ IMPORTANTE: LEIA ATENTAMENTE E GUARDE PARA CONSULTA FUTURA.**

**DE\_ WICHTIG! SORGFÄLTIG LESEN UND FÜR SPÄTER NACHSCHLAGEN AUFBEWAHREN.**

**IT\_ IMPORTANTE! CONSERVARE IL PRESENTE MANUALE PER FUTURO RIFERIMENTO E LEGGERLO ATTENTAMENTE.**

**RO\_ IMPORTANT: CITIȚI CU ATENȚIE ȘI PĂSTRAȚI PENTRU CONSULTARE VIITOARE.**

A x 1

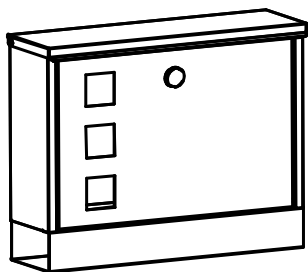

B x 4

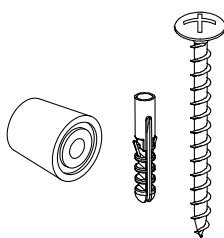

C x 1



01

- EN** Please make sure that the notch on the key is aligned with the red dot on the lock  
**FR** Veillez à ce que l'encoche de la clé soit alignée sur le point rouge de la serrure.  
**ES** Asegúrese de que la muesca de la llave está alineada con el punto rojo de la cerradura.  
**PT** Certifique-se de que o entalhe da chave está alinhado com o ponto vermelho do cadeado  
**DE** Achten Sie bitte darauf, dass die Kerbe am Schlüssel mit dem roten Punkt am Schloss übereinstimmt.  
**IT** Assicurarsi che la tacca della chiave sia allineata con il punto rosso della serratura.  
**RO** Asigurați-vă că creștătura de pe cheie este aliniată cu punctul roșu de pe încuietoare

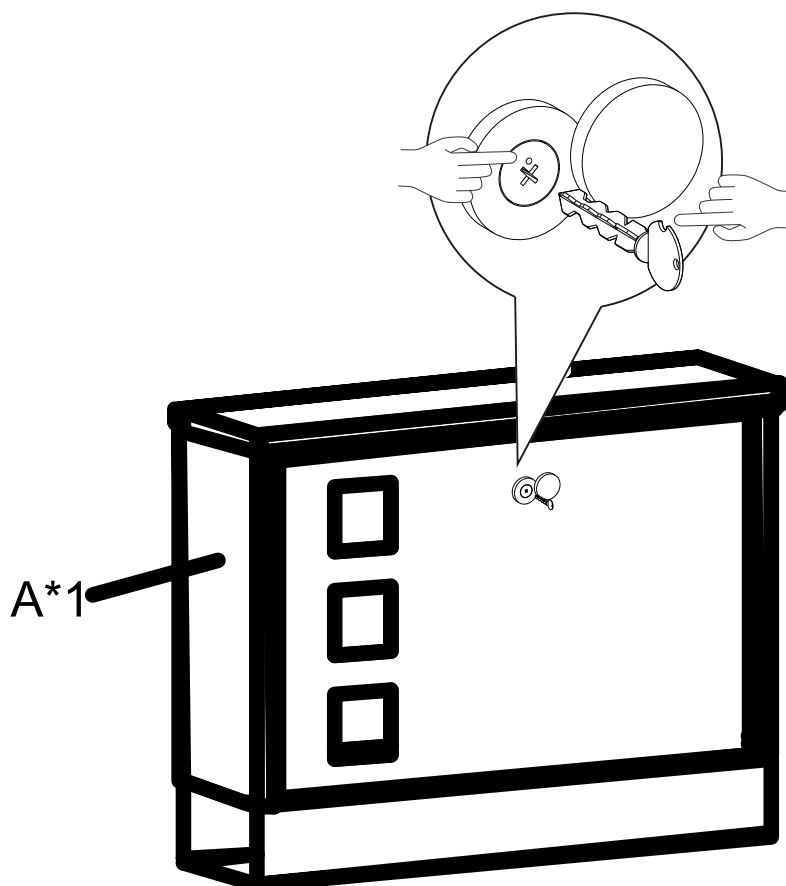

**EN\_** Considering varying climates of different regions, We recommends you install or place it in a weather-protected location with the accessories, ensuring your mailbox remains in good condition for a long time.

**FR\_** Compte tenu des différences de climat entre les régions, nous vous recommandons de l'installer ou de la placer à l'abri des intempéries avec les accessoires, afin que votre boîte aux lettres reste en bon état pendant longtemps.

**ES\_** Teniendo en cuenta los diferentes climas de las distintas regiones, le recomendamos que lo instale o coloque en un lugar protegido de la intemperie con los accesorios, para garantizar que su buzón se mantenga en buen estado durante mucho tiempo.

**PT\_** Tendo em conta os diferentes climas das diferentes regiões, recomendamos que a instale ou coloque num local protegido das intempéries com os acessórios, garantindo que a sua caixa de correio se mantêm em boas condições durante muito tempo.

**DE\_** In Anbetracht der unterschiedlichen klimatischen Bedingungen in den verschiedenen Regionen empfehlen wir Ihnen, den Briefkasten zusammen mit dem Zubehör an einem wettergeschützten Ort zu installieren oder aufzustellen, damit er lange Zeit in gutem Zustand bleibt.

**IT\_** Considerando i diversi climi delle varie regioni, vi consigliamo di installarla o posizionarla in un luogo protetto dalle intemperie con gli accessori, per garantire che la vostra cassetta postale rimanga in buone condizioni per lungo tempo.

**RO\_** Având în vedere condițiile climatice variate din diferite regiuni, vă recomandăm să instalați sau să amplasați cutia poștală într-un loc ferit de intemperii, împreună cu accesoriile, pentru a vă asigura că aceasta se va menține în stare bună pentru o perioadă îndelungată.

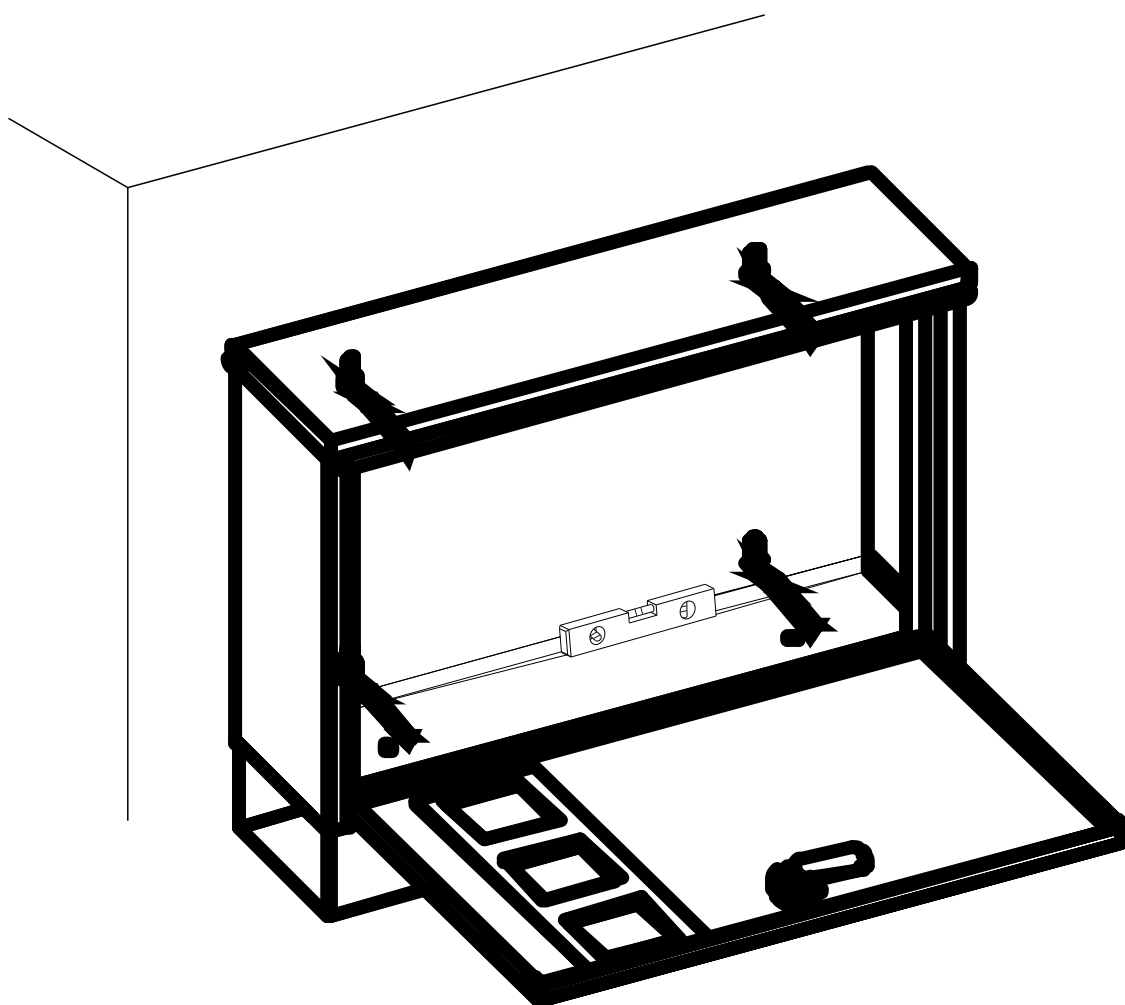

**EN** If it is a solid wall, please use expansion and self-tapping screws, if it is a wooden wall, only use self-tapping screws, please do not overtighten the screws

**FR** Si le mur est massif, veuillez utiliser des chevilles à expansion et des vis autotaraudeuses, mais s'il s'agit d'un mur en bois, utilisez uniquement des vis autotaraudeuses et ne serrez pas trop les vis.

**ES** Para una pared sólida, utilice los tornillos de expansión y autorroscantes. Para una pared de madera, utilice exclusivamente los tornillos autorroscantes, no los apriete demasiado.

**PT** Se for uma parede sólida, use por favor parafusos de expansão e auto-roscantes, se for uma parede de madeira, use apenas parafusos auto-roscantes, por favor não aperte demasiado os parafusos.

**DE** Wenn es sich um eine Massivwand handelt, verwenden Sie bitte Dehnungs- und selbstschneidende Schrauben. Wenn es sich um eine Holzwand handelt, verwenden Sie nur selbstschneidende Schrauben, bitte ziehen Sie die Schrauben nicht zu fest an.

**IT** Se si tratta di un muro solido, utilizzare sia viti ad espansione che autofilettanti. Se si tratta di una parete in legno, utilizzare solo viti autofilettanti, non stringere eccessivamente le viti.

**RO** Dacă este vorba de un perete din beton, vă rugăm să folosiți șuruburi cu cap de expansiune și șuruburi autofiletante; dacă este un perete din lemn, folosiți numai șuruburi autofiletante; vă rugăm să nu strângeți prea tare șuruburile

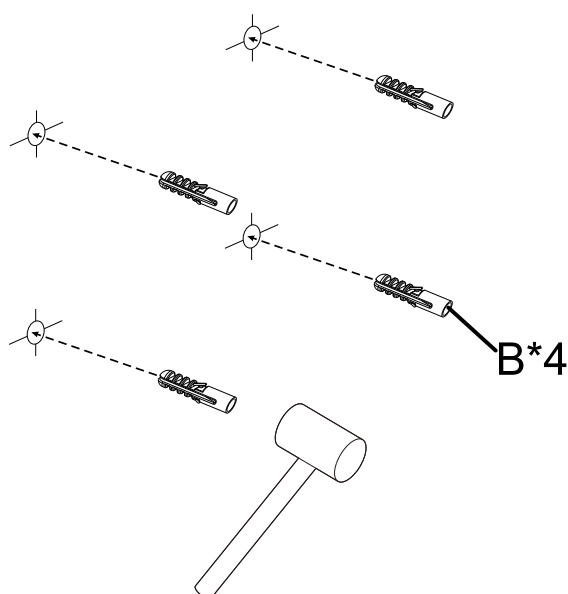
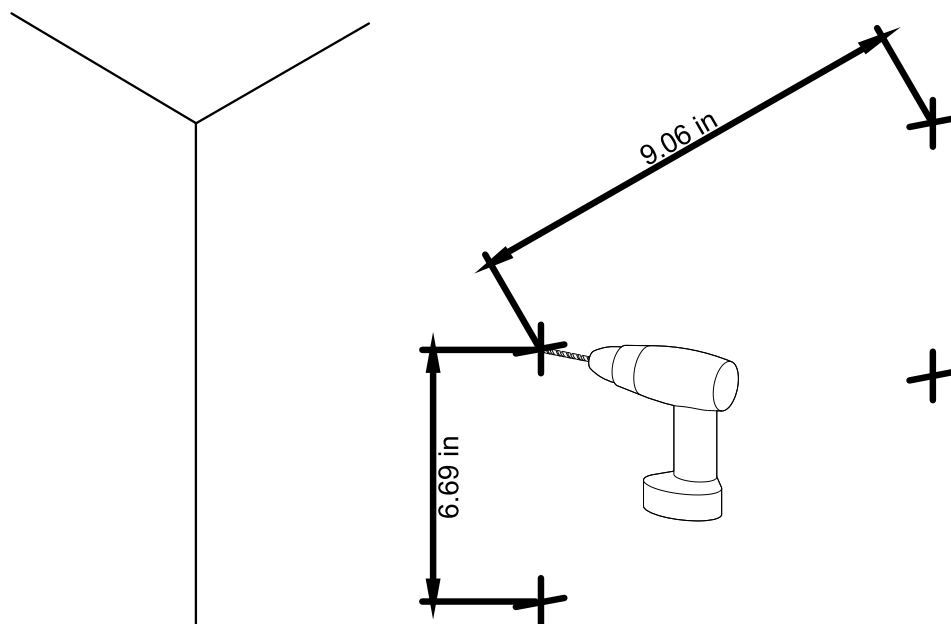

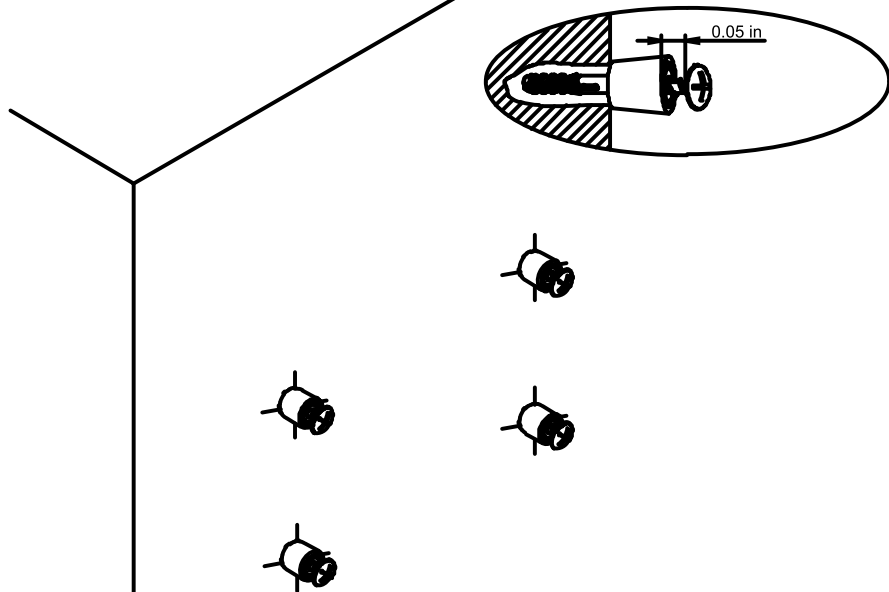
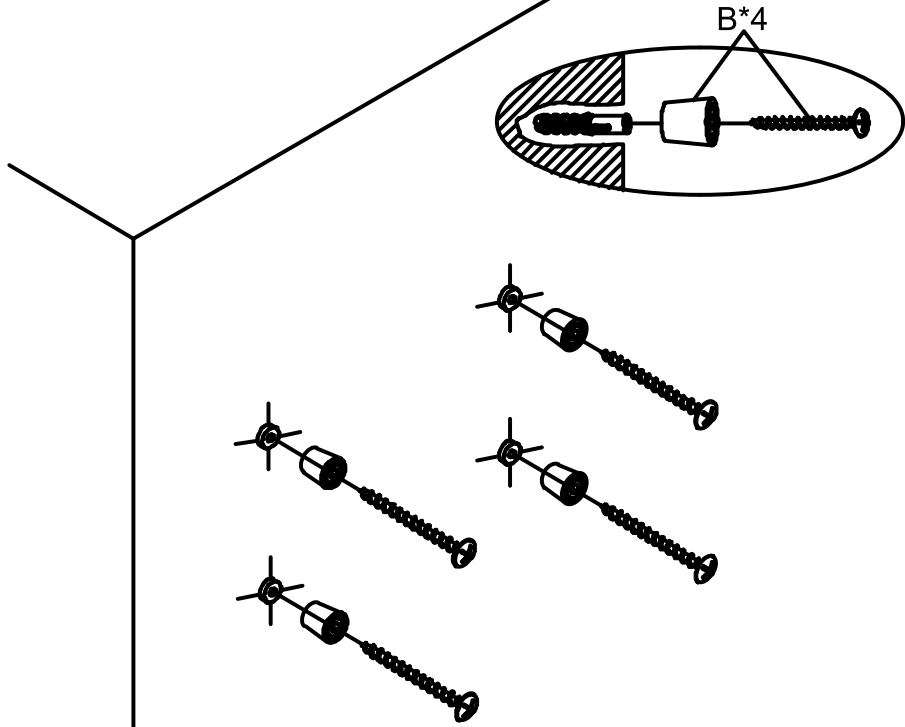

07

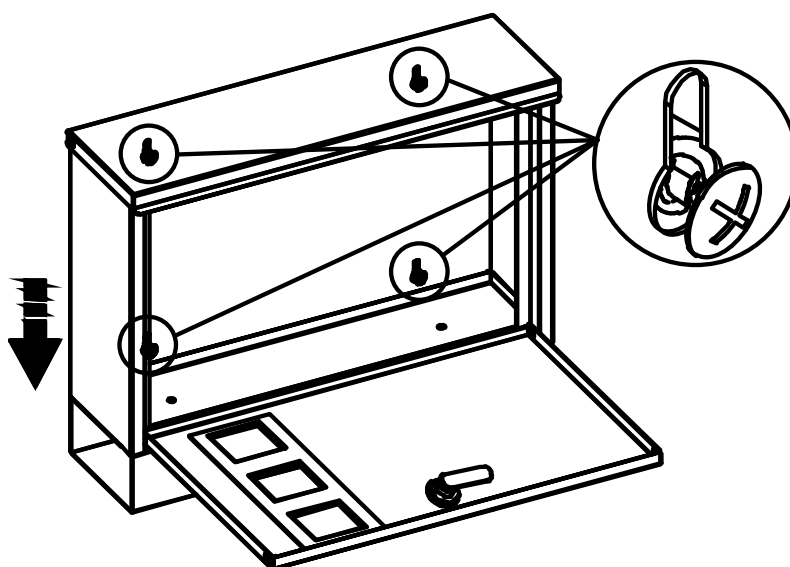

08

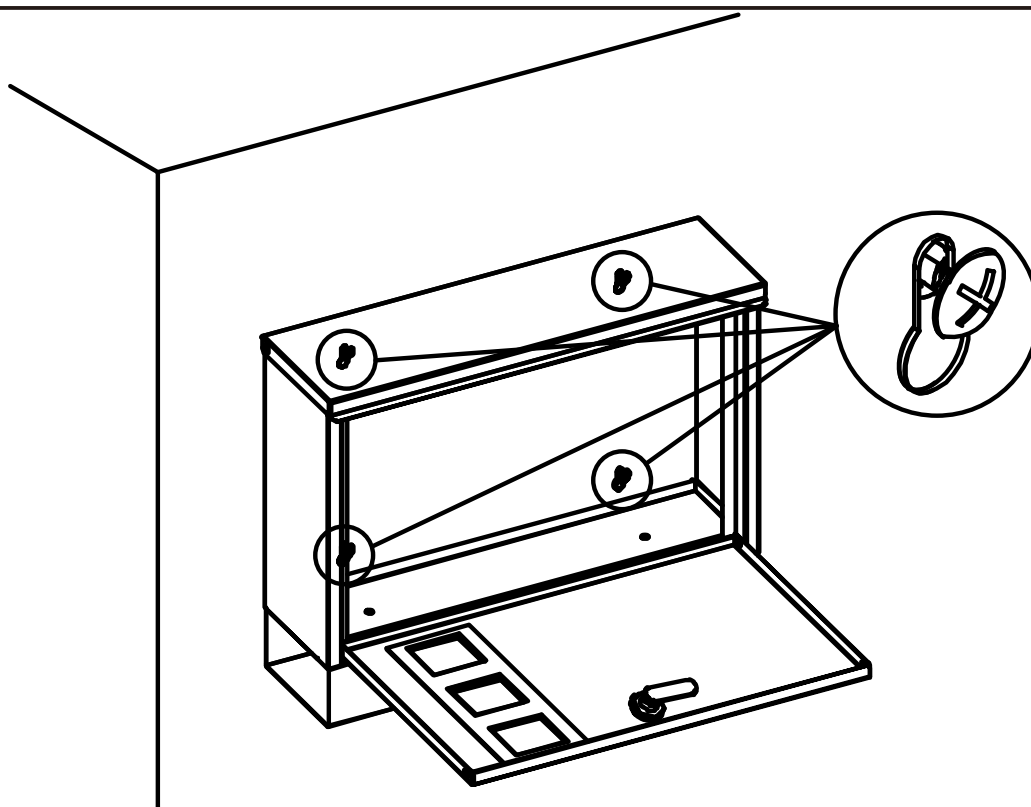

**EN\_** After the mailbox is hung up, please tighten the two screws on the top.

**FR\_** Une fois la boîte aux lettres accrochée, serrez les deux vis situées sur le dessus.

**ES\_** Una vez colgado el buzón, apriete los dos tornillos de la parte superior.

**PT\_** Depois de pendurar a caixa de correio, aperte os dois parafusos na parte superior.

**DE\_** Nachdem der Briefkasten aufgehängt wurde, ziehen Sie bitte die beiden Schrauben an der Oberseite fest.

**IT\_** Dopo aver appeso la cassetta postale, serrare le due viti sulla parte superiore.

**RO\_** După ce ați montat cutia poștală, vă rugăm să strângeți cele două șuruburi din partea de sus.

**EN\_** The attached cable tie is only a gift. Considering varying fences of different families, you may need to consult a professional from the local hardware store if it's not suitable.

**FR\_** Le collier de serrage n'est qu'un cadeau. Étant donné que les clôtures varient d'une famille à l'autre, il peut être nécessaire de consulter un professionnel de la quincaillerie locale si cela ne convient pas.

**ES\_** El sujetacables adjunto es sólo un regalo. Teniendo en cuenta las diferentes vallas de diferentes familias, puede que tenga que consultar a un profesional de la ferretería local si no es adecuado.

**PT\_** A abraçadeira anexa é apenas uma prenda. Tendo em conta que as vedações variam consoante as famílias, pode ser necessário consultar um profissional da loja de ferragens local se não for adequado.

**DE\_** Der angebrachte Kabelbinder ist nur ein Geschenk. In Anbetracht der unterschiedlichen Zäune der verschiedenen Familien, müssen Sie möglicherweise einen Fachmann aus dem örtlichen Baumarkt zu konsultieren, wenn es nicht geeignet ist.

**IT\_** La fascetta allegata è solo un omaggio. Considerando che le recinzioni variano a seconda delle famiglie, se non è adatta, potrebbe essere necessario consultare un professionista della ferramenta locale.

**RO\_** Clemă de cablu atașată este doar un cadou. Având în vedere diversitatea gardurilor de la diferite familii, s-ar putea să fie necesar să consultați un specialist de la magazinul local de bricolaj, în cazul în care aceasta nu este potrivită.

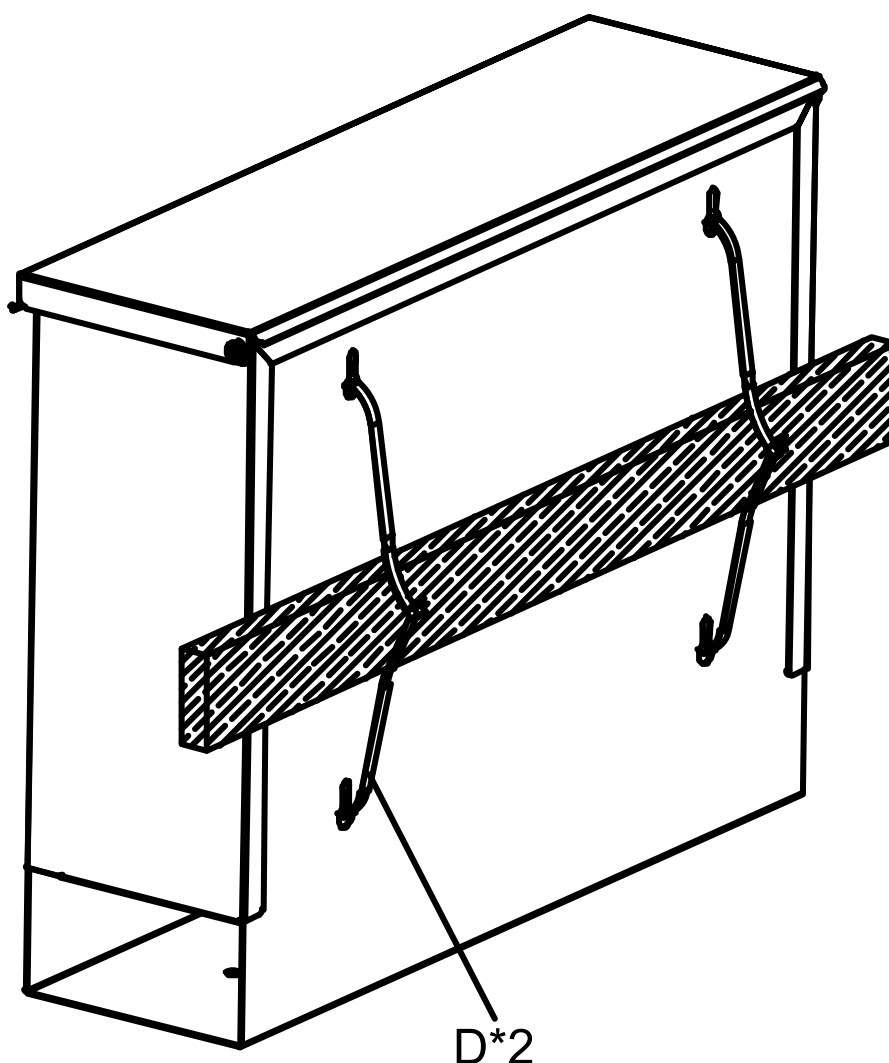

If you have any questions, please contact our customer care center, Our contact details are below:

**US**

 001-877-644-9366

 customerservice@aosom.com

Imported by Aosom LLC  
7777 Center Ave. Suite 430  
Huntington Beach, CA 92647-9998 USA  
MADE IN CHINA

If you have any questions, please contact our customer care center, Our contact details are below:

**CA**

 416-792-6088

 customerservice@aosom.ca

Imported by Aosom Canada Inc.  
7270 Woodbine Avenue, Unit 307, Markham,  
Ontario Canada L3R 4B9  
MADE IN CHINA

Si vous avez la moindre question, veuillez contacter notre centre d'assistance à la clientèle, Nos coordonnées sont les suivantes:

 416-792-6088

 customerservice@aosom.ca

Importé par Aosom Canada Inc.  
7270 Woodbine Avenue, unité 307,  
Markham, Ontario Canada L3R 4B9  
FABRIQUÉ EN CHINE

If you have any questions, please contact our customer care center, Our contact details are below:

**UK**

 0044-800-240-4004

 enquiries@mhstar.co.uk

IMPORTER ADDRESS:  
MH STAR UK Ltd  
1 Northampton Cross Logistics Park  
Northampton Cross Road  
Northampton  
NN4 9FH  
MADE IN CHINA

Si vous avez la moindre question, veuillez contacter notre centre d'assistance à la clientèle, Nos coordonnées sont les suivantes:

 0033-1-84166106

 aosom@mhfrance.fr

Importé par/Fabricant/REP:  
MH FRANCE  
2 Rue Maurice Hartmann  
92130 Issy Les Moulineaux  
France  
FABRIQUÉ EN CHINE

Si tiene alguna pregunta, comuníquese con nuestro Centro de Atención al Cliente, Nuestros datos de contacto son los siguientes:

**ES**

 0034-931294512

 atencioncliente@aosom.es

IMPORTADOR/Fabricante/REP:  
SPANISH AOSOM, S.L.  
C/ROC GROS, N°15.08550, ELS HOSTALETS DE  
BALENYÀ, SPAIN.  
B66295775  
HECHO EN CHINA

Se tiver alguma dúvida, por favor contacte o nosso Centro de Atendimento ao Cliente, Os nossos dados de contacto são os seguintes:

 0034-931294512

 info@aosom.pt.

IMPORTADOR/Fabricante/REP:  
SPANISH AOSOM, S.L.  
C.ROC GROS N.15, 08550. ELS HOSTALETS DE  
BALENYÀ  
FEITO NA CHINA

In caso di dubbio, si prega di contattare il nostro centro assistenza clienti, I nostri dettagli di contatto sono di seguito:

**IT**

 0039-0249471447

 clienti@aosom.it

IMPORTATO DA/Produttore/REP:  
AOSOM Italy srl  
Centro Direzionale Milanofiori  
Strada 1 Palazzo F1  
20057 Assago (MI)  
P.I.: 08567220960  
FATTO IN CINA

Wenn Sie Fragen haben, wenden Sie sich bitte an unser Kundendienstzentrum, Unsere Kontaktdaten stehen unten:

**DE**

 0049-0(40)-87408465

 service@aosom.de

ADRESSE DES IMPORTEURE/Hersteller/REP:  
MH Handel GmbH  
Wendenstraße 309  
D-20537 Hamburg  
Germany  
IN CHINA HERGESTELLT

Si vous avez la moindre question, veuillez contacter notre centre d'assistance à la clientèle, Nos coordonnées sont les suivantes:

**FR**

 0033-1-84166106

 aosom@mhfrance.fr

Importé par/Fabricant/REP:  
MH FRANCE  
2 Rue Maurice Hartmann  
92130 Issy Les Moulineaux  
France  
FABRIQUÉ EN CHINE



FR

**DONNEZ  
OU  
RECYCLEZ**



ASSOCIATION

OU



LIVRAISON

OU



DÉCHÈTERIE

Adresses sur [quefairedemesdechets.fr](http://quefairedemesdechets.fr)