

# 83A-037V80\_83A-037V81

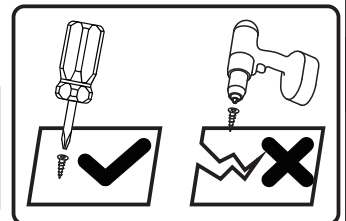
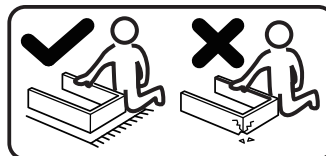
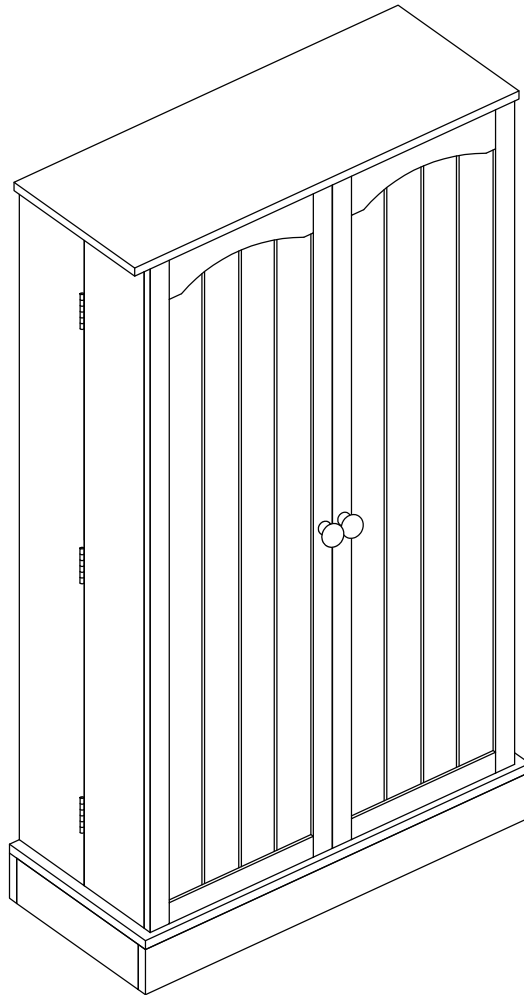

Tools Recommended

**EN\_ IMPORTANT, RETAIN FOR FUTURE REFERENCE: READ CAREFULLY.**

**FR\_ IMPORTANT: A LIRE ATTENTIVEMENT ET À CONSERVER POUR CONSULTATION ULTÉRIEURE.**

**ES\_ IMPORTANTE, LEA Y GUARDE PARA FUTURAS REFERENCIAS.**

**PT\_ IMPORTANTE: LEIA ATENTAMENTE E GUARDE PARA CONSULTA FUTURA.**

**DE\_ WICHTIG! SORGFÄLTIG LESEN UND FÜR SPÄTER NACHSCHLAGEN AUFBEWAHREN.**

**IT\_ IMPORTANTE! CONSERVARE IL PRESENTE MANUALE PER FUTURO RIFERIMENTO E LEGGERLO ATTENTAMENTE.**

**RO\_ IMPORTANT: CITIȚI CU ATENȚIE ȘI PĂSTRAȚI PENTRU CONSULTARE VIITOARE.**

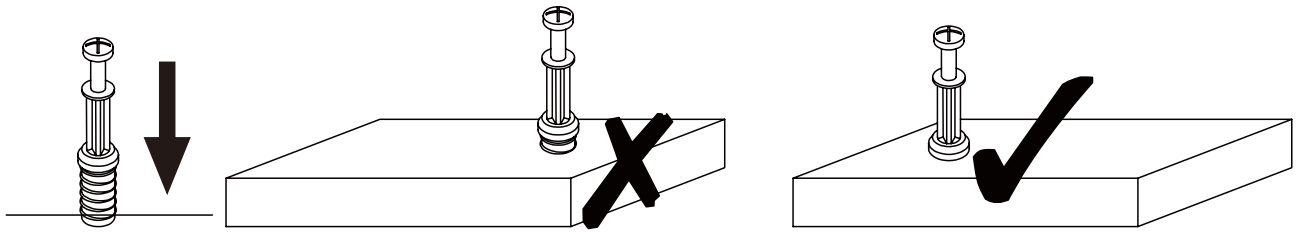

**EN\_ QUICKFIT:** Tighten quickfit until shoulder is flush with panel. Do not overtighten or undertighten.

**FR\_ RACCORD RAPIDE:** Faites serrer le raccord rapide jusqu'à ce que l'épaulement soit parfaitement encastré dans le panneau. Il ne faut ni trop serrer ni insuffisamment serrer.

**ES\_ QUICKFIT:** Apriete quickfit hasta que el hombro se descargue con el panel. NO lo sobreapriete ni lo apriete poco.

**PT\_ AJUSTE RÁPIDO:** Aperte o ajuste rápido até estar nivelada com o painel. Não apertar demasiado ou excessivamente.

**DE\_ QUICKFIT:** Ziehen Sie den Quickfit fest, bis die Schulter mit der Platte bündig ist. Bitte nicht zu fest oder zu schwach anziehen.

**IT\_ MONTAGGIO RAPIDO:** Stringere il montaggio rapido fino a quando la spalla è a filo con il pannello, non stringere troppo o troppo poco.

**RO\_ QUICKFIT:** Strângeți quickfit până când umărul este la același nivel cu panoul. Nu strângeți prea tare și nici prea slab.

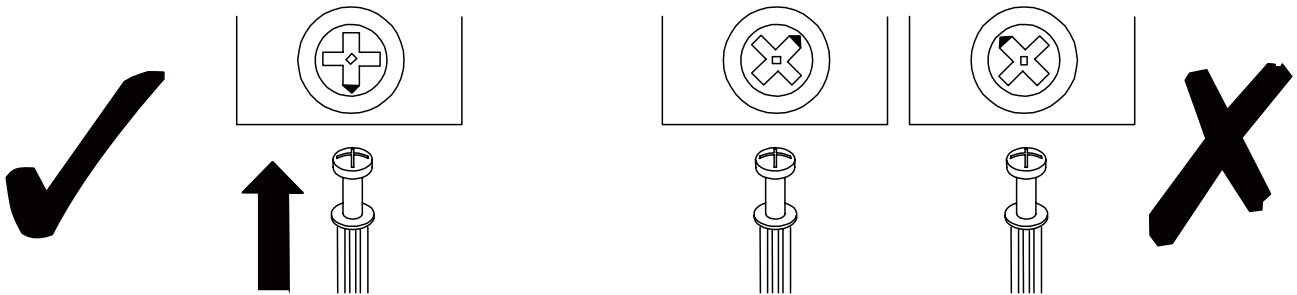

**EN\_ CAM LOCK:** When fitting cam lock, ensure starting position is correct before you insert connecting quickfit.

**FR\_ SERRURE BATTEUSE:** Avant d'insérer la serrure batteuse, veillez à la bonne orientation avant d'insérer le raccord rapide.

**ES\_ CIERRE DE LA CÁMARA:** Cuando instale el cierre de la cámara, asegúrese de que la posición de inicio es correcta antes de que inserte el quickfit conector.

**PT\_ BLOQUEIO:** Ao instalar o bloqueio, assegurar-se de que a posição inicial está correcta antes de inserir o encaixe de ligação rápida.

**DE\_ CAM-LOCK:** Achten Sie bei der Montage des Cam-Locks auf die richtige Ausgangsposition, bevor Sie den Quickfit einsetzen.

**IT\_ BLOCCAGGIO A CAMMA:** Quando si monta il bloccaggio a camma, assicurarsi che la posizione iniziale sia corretta prima di inserire il montaggio rapido di collegamento.

**RO\_ BLOCARE CU CAME:** Când montați blocarea cu came, asigurați-vă că poziția inițială este corectă înainte de a introduce racordul rapid.

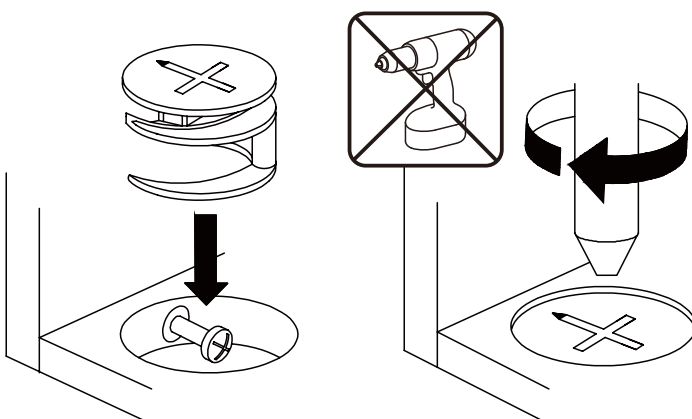

**EN\_** Turn cam lock clockwise to tighten.

**FR\_** Faites tourner la serrure batteuse dans le sens des aiguilles d'une montre pour la resserrer.

**ES\_** Gire el cierre de la cámara en sentido horario para apretarlo.

**PT\_** Rodar o bloqueio no sentido dos ponteiros do relógio para o apertar.

**DE\_** Drehen Sie den Cam-Lock im Uhrzeigersinn, um ihn festzuziehen.

**IT\_** Ruotare il bloccaggio a camma in senso orario per stringere.

**RO\_** Rotiți blocarea cu came în sensul acelor de ceasornic pentru a strânge.

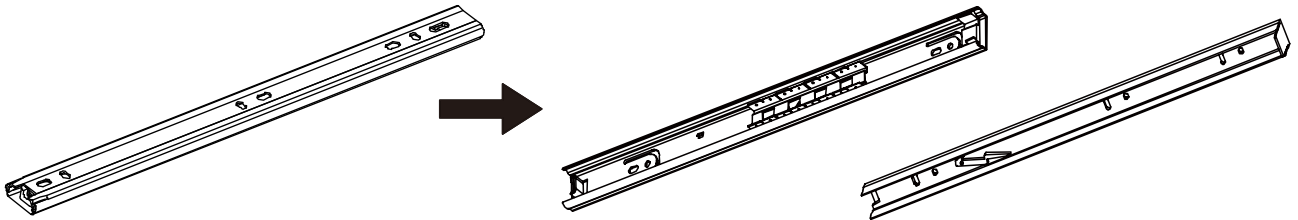

**EN\_NOTE:** Pull inner and outer drawer runners apart before fixing them to panels.

**FR\_REMARQUE:** Avant de fixer les glissières de tiroir aux panneaux, tirez vers l'extérieur et poussez vers l'intérieur de chacun des tiroirs.

**ES\_NOTA:** retire los rieles interiores y exteriores antes de fijarlos a los paneles.

**PT\_NOTA:** Separar as corrediças das gavetas interiores e exteriores antes de fixar para os painéis.

**DE\_HINWEIS:** Ziehen Sie die inneren und äußeren Schubladenführung auseinander, bevor Sie sie an den Platten befestigen.

**IT\_NOTA:** Separare le guide interne ed esterne del cassetto prima di fissarle ai pannelli.

**RO\_NOTĂ:** Desfaceți glisierile interioare și exterioare ale sertarului înainte de a le fixa pe panouri.



**EN\_Slide** drawer runners apart until the drawer lock can be seen, as shown.

**FR\_** Les glissières de tiroir doivent être ouvertes jusqu'à ce que la serrure du tiroir soit visible, comme indiqué.

**ES\_** Deslice a un lado los rieles del cajón hasta que se pueda ver el cierre del armario, tal y como se muestra.

**PT\_** Deslizam-se as gavetas até se poder ver o fecho da gaveta, como se mostra.

**DE\_** Schieben Sie die Schubladenführungen auseinander, bis das Schubladenschloss sichtbar ist, gemäß der Abbildung.

**IT\_** Far scorrere le guide del cassetto fino a quando non sia visibile il blocco di scorrimento, come mostrato.

**RO\_** Trageți glisierile sertarului până când se vede dispozitivul de blocare a sertarului, așa cum se arată în imagine.

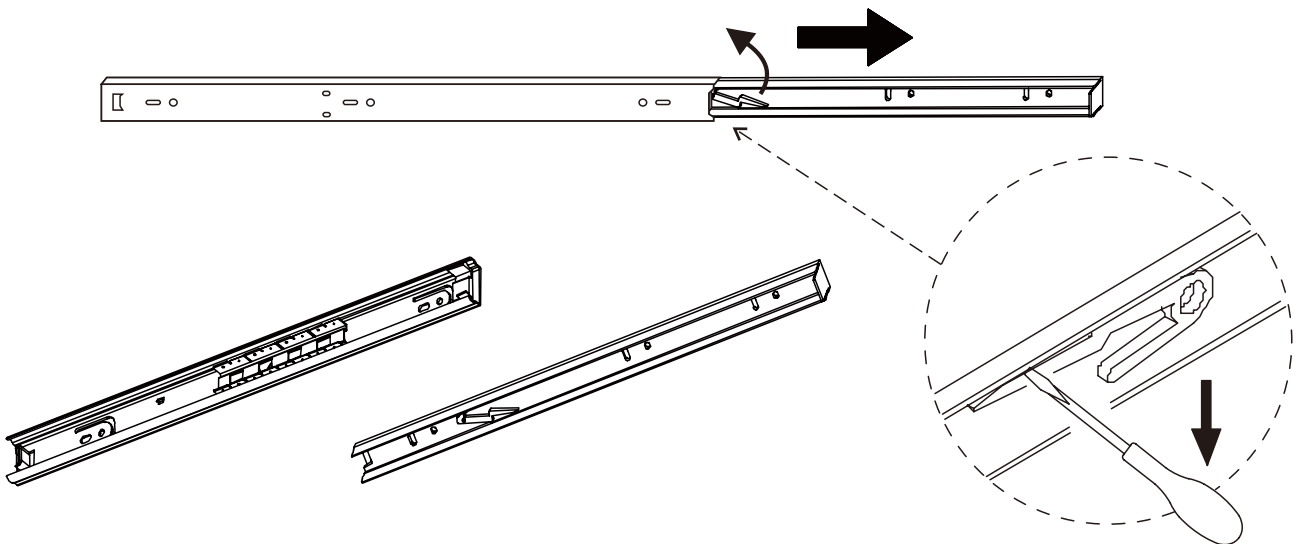

**EN\_Press** and hold the drawer runner lock and then continue to slide drawer runners apart, as shown.

**FR\_** En appuyant et en maintenant le verrouillage des glissières de tiroir, vous pouvez continuer à les écarter l'une de l'autre, comme indiqué.

**ES\_** Mantenga presionado el cierre del riel del cajón y después continúe deslizando a un lado los rieles de los cajones, tal y como se muestra.

**PT\_** Manter pressionado o fecho de gaveta e depois continuar a deslizar as corrediças da gaveta, como mostrado.

**DE\_** Drücken und halten Sie die Verriegelung der Schubladenführung und schieben Sie die Schubladenführungen wie abgebildet weiter auseinander.

**IT\_** Tenere premuto il blocco di scorrimento e quindi continuare a far scorrere la guida, come mostrato.

**RO\_** Apăsați și țineți apăsat dispozitivul de blocare a glisierelor sertarului, apoi continuați să glisați glisierile sertarului în direcții opuse, așa cum se arată în imagine.

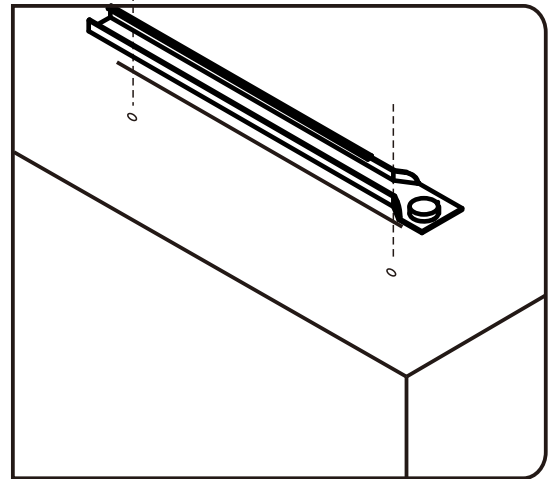
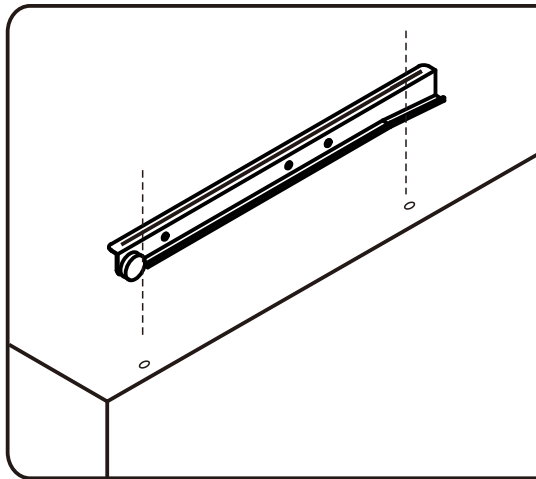
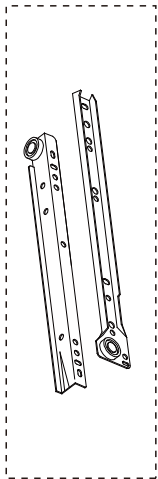

**EN\_** Please find the exact hole for installation, otherwise it will be misaligned. The screws on the drawer slide must be leveled, otherwise it will affect the smoothness of the drawer.

**FR\_** Identifiez le trou exact pour l'installation, sinon il sera mal aligné. Les vis de la glissière du tiroir doivent être nivelées, sinon cela affectera le fonctionnement du tiroir.

**ES\_** Al instalar, encuentre el orificio exacto; de lo contrario, estará desalineado. Los tornillos en las correderas del cajón deben estar nivelados, de lo contrario, afectará la suavidad al deslizar el cajón.

**PT\_** Por favor encontre o orifício exacto para instalação, caso contrário será desalinhado. Os parafusos na corredeira da gaveta devem ser nivelados, caso contrário afetará a suavidade da abertura da gaveta.

**DE\_** Bitte finden Sie das genaue Loch für die Installation, sonst wird es falsch ausgerichtet werden. Die Schrauben an der Schubladenföhrung müssen nivelliert werden, da sonst die Leichtgängigkeit der Schublade beeinträchtigt wird.

**IT\_** individuare il foro esatto per l'installazione, altrimenti ci sarà un disallineamento. Le viti sulla guida del cassetto devono essere allineate, altrimenti influirà sulla scorrevolezza del cassetto.

**RO\_** Găsiți orificiul exact pentru instalare, altfel acesta va fi aliniat incorect. Șuruburile de pe glisiera sertarului trebuie să fie nivelate, altfel aceasta va afecta funcționarea lină a sertarului.

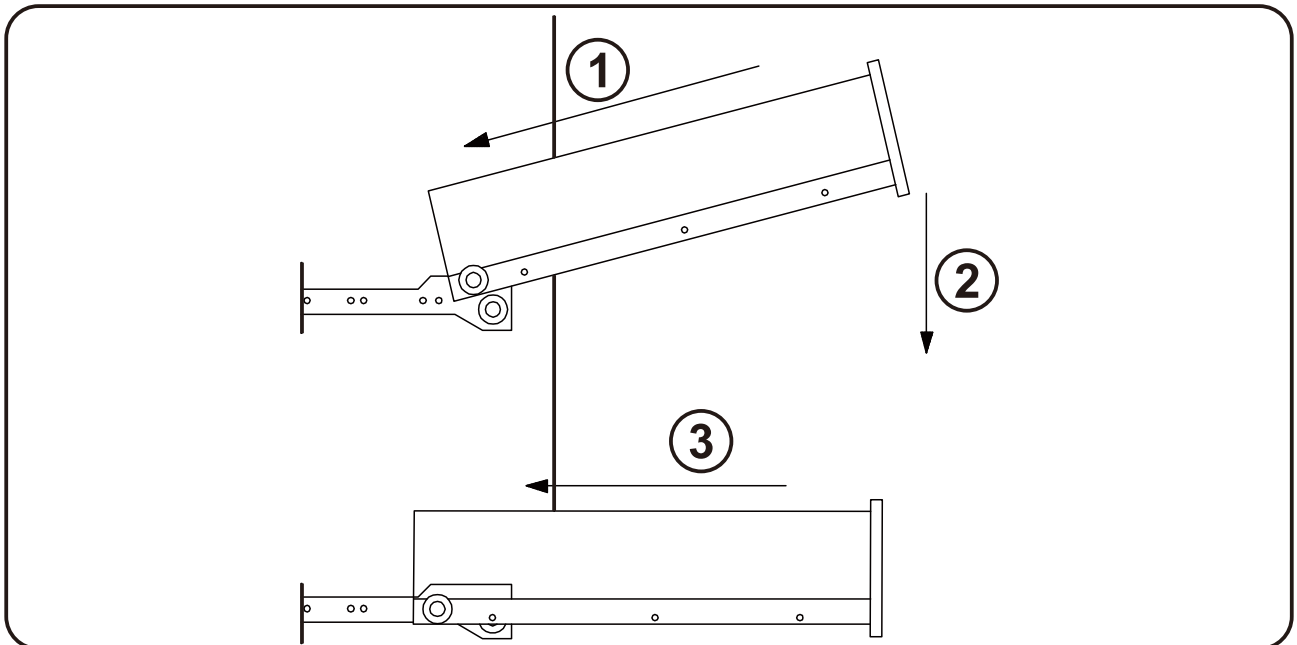

**EN\_** Be careful to push in the board when the both sides slide way been aligned.

**FR\_** Prenez soin d'enfoncer la planche lorsque les deux côtés de la glissière sont alignés.

**ES\_** Empuje con cuidado el tablero después de que los dos lados se hayan alineado.

**PT\_** Ter o cuidado de empurrar a placa quando os dois lados estiverem alinhados.

**DE\_** Achten Sie darauf, dass Sie die Platte einschieben, wenn die beiden Seiten so ausgerichtet sind, dass sie gleiten.

**IT\_** Fare attenzione quando si spinge il cassetto quando le due guide di scorrimento sono state allineate.

**RO\_** Aveți grijă să împingeți placa atunci când ambele părți sunt aliniate.

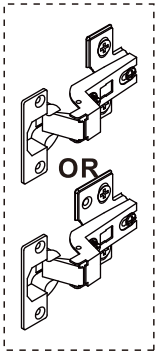

**EN\_** It may be necessary to adjust the hinges so that the doors align. Use the instructions below as a guide.  
**FR\_** Il est parfois nécessaire d'ajuster les charnières pour un meilleur alignement des portes. Servez-vous des instructions ci-dessous comme guide.  
**ES\_** Puede que sea necesario ajustar los quicios de forma que se alineen las puertas. Use las instrucciones que aparecen debajo como guía.  
**PT\_** Pode ser necessário ajustar as dobradiças para que as portas fiquem alinhadas. Utilizar as instruções abaixo como guia.  
**DE\_** Möglicherweise müssen Sie die Scharniere so einstellen, dass die Türen ausgerichtet sind. Verwenden Sie die nachstehenden Anweisungen als Leitfaden.  
**IT\_** Potrebbe essere necessario regolare le cerniere in modo che le porte siano allineate. Per fare ciò attenersi alle istruzioni sottostanti.  
**RO\_** Poate fi necesar să reglați balamalele pentru ca ușile să se alinieze. Folosiți instrucțiunile de mai jos ca ghid.

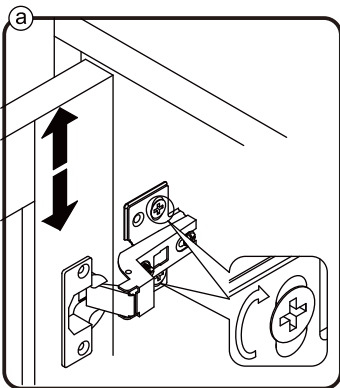

**EN\_** To adjust the door vertically loosen the screw as shown and move up and down as needed.  
**FR\_** Si vous souhaitez régler la porte verticalement, desserrez la vis comme indiqué et déplacez la porte de haut en bas selon les besoins.  
**ES\_** Para ajustar la puerta verticalmente afloje el tornillo tal y como se muestra y muévelo hacia arriba o hacia abajo según sea necesario.  
**PT\_** Para ajustar a porta na vertical, soltar o parafuso mostrado e mover-se para cima e para baixo, conforme necessário.  
**DE\_** Um die Tür vertikal auszurichten, lösen Sie die Schraube wie abgebildet und bewegen Sie sie nach Bedarf nach oben oder nach unten.  
**IT\_** Per allineare la porta verticalmente allentare la vite come mostrato e spostarla in alto o in basso secondo necessità.  
**RO\_** Pentru a regla ușa pe verticală, slăbiți șurubul așa cum se arată și mișcați în sus și în jos, după cum este necesar.

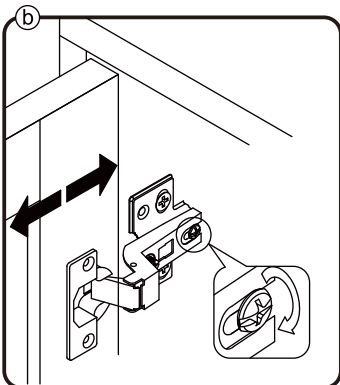

**EN\_** To adjust the gap from the door to the main frame turn the screw clockwise or anti-clockwise as needed.  
**FR\_** Si vous souhaitez ajuster l'écart entre la porte et le cadre principal, tournez la vis dans le sens des aiguilles d'une montre ou dans le sens inverse, si nécessaire.  
**ES\_** Para ajustar el espacio desde la puerta al marco principal, gire el tornillo en sentido horario o antihorario, según se necesite.  
**PT\_** Para ajustar o espaço entre a porta e o quadro principal, rode o parafuso no sentido dos ponteiros do relógio ou anti-horário, conforme necessário.  
**DE\_** Um den Abstand von der Tür zum Hauptrahmen auszurichten, drehen Sie die Schraube je nach Bedarf im oder gegen den Uhrzeigersinn.  
**IT\_** Per regolare lo spazio tra la porta e il telaio principale, avvitate o svitate la vite secondo necessità.  
**RO\_** Pentru a regla distanța dintre ușă și cadrul principal, rotiți șurubul în sensul acelor de ceasornic sau în sens invers acelor de ceasornic, după cum este necesar.

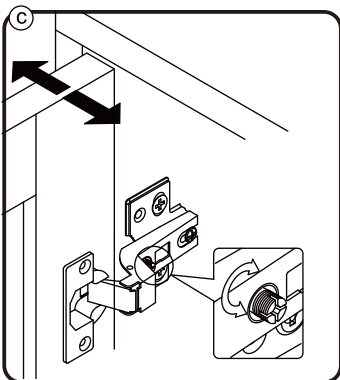

**EN\_** To adjust the door laterally adjust the screw as shown by turning clockwise or anti-clockwise.  
**FR\_** Si vous souhaitez ajuster la porte latéralement, ajustez la vis comme indiqué en tournant dans le sens des aiguilles d'une montre ou dans le sens inverse des aiguilles d'une montre.  
**ES\_** Para ajustar la puerta lateralmente ajuste el tornillo tal y como se muestra girándolo en sentido horario y antihorario.  
**PT\_** Para ajustar a porta lateralmente ajustar o parafuso, conforme indicado, rodando no sentido dos ponteiros do relógio ou no sentido anti-horário.  
**DE\_** Um die Tür seitlich auszurichten, stellen Sie bitte die Schraube wie abgebildet durch Drehen im oder gegen den Uhrzeigersinn ein.  
**IT\_** Per allineare la porta lateralmente regolare la vite come mostrato, avvitandola o svitandola.  
**RO\_** Pentru a regla ușa lateral, reglați șurubul așa cum se arată, rotindu-l în sensul acelor de ceasornic sau în sens invers acelor de ceasornic.

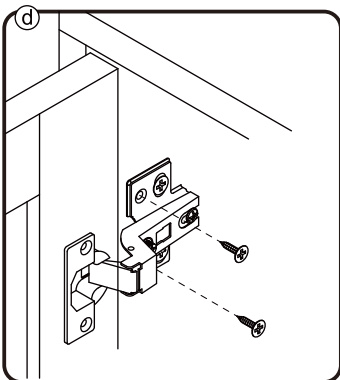

**EN\_** Please fix other screws  
**FR\_** Merci de serrer les autres vis.  
**ES\_** Fije los demás tornillos  
**PT\_** Por favor fixe os outros parafusos  
**DE\_** Befestigen Sie bitte die anderen Schrauben  
**IT\_** Fissare le altre viti  
**RO\_** Vă rugăm să fixați celelalte șuruburi.

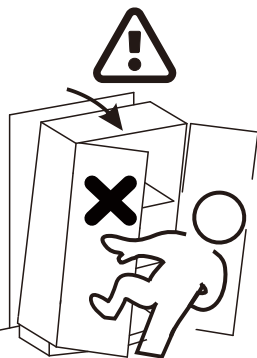
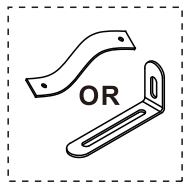

**EN\_** This is anti-dumping belt that fix the product to the wall and it can be used or not follow your needs.

**FR\_** Cette sangle anti-basculement permet de fixer le produit au mur. Elle peut être utilisée ou non selon vos besoins.

**ES\_** Esta es una correa anti-vuelco para fijar el producto a la pared, y según sus necesidades, puede utilizarla o no.

**PT\_** Este é o sistema anti-tombo que fixa o produto à parede e pode ser usado para uma maior segurança.

**DE\_** Dies ist Anti-Sturz-Gurt, um das Gerät an der Wand zu befestigen und es kann je nach Bedarf verwendet oder nicht verwendet werden.

**IT\_** Questa è una cintura anticaduta che fissa il prodotto alla parete e può essere utilizzata o meno a seconda delle vostre esigenze.

**RO\_** Aceasta este o centură anti-dumping care fixează produsul pe perete și poate fi utilizată sau nu, în funcție de necesități.

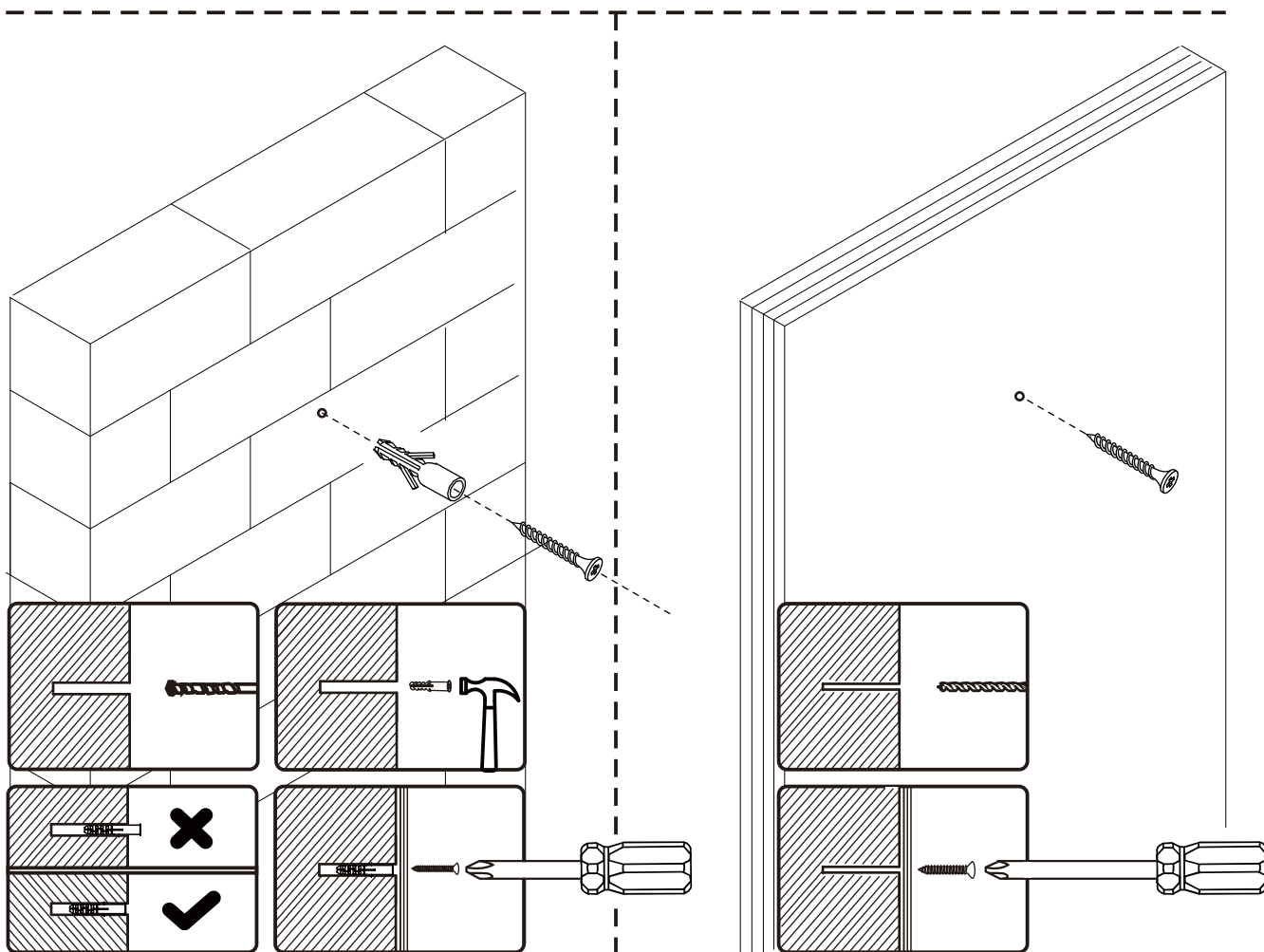

**EN\_** If it is a solid wall, please use expansion and self-tapping screws, if it is a wooden wall, only use self-tapping screws, please do not overtighten the screws

**FR\_** Si le mur est massif, veuillez utiliser des chevilles à expansion et des vis autotaraudeuses, mais s'il s'agit d'un mur en bois, utilisez uniquement des vis autotaraudeuses et ne serrez pas trop les vis.

**ES\_** Para una pared sólida, utilice los tornillos de expansión y autorroscantes. Para una pared de madera, utilice exclusivamente los tornillos autorroscantes, no los apriete demasiado.







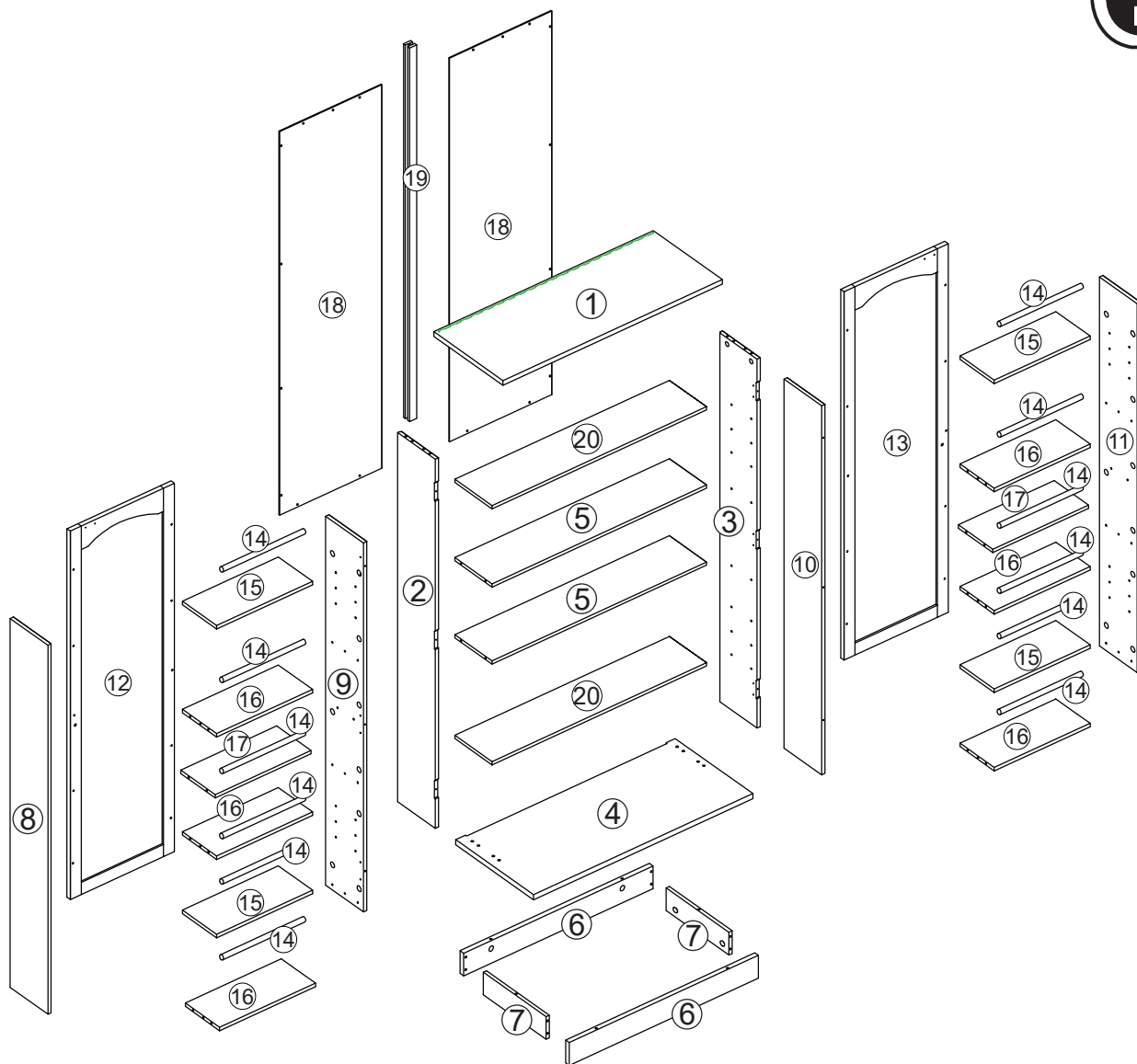

**PT\_** Se for uma parede sólida, use por favor parafusos de expansão e auto-roscantes, se for uma parede de madeira, use apenas parafusos auto-roscantes, por favor não aperte demasiado os parafusos.

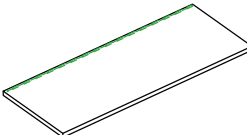
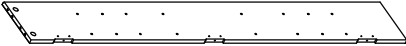

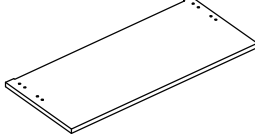
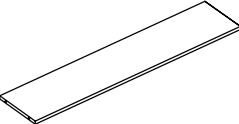
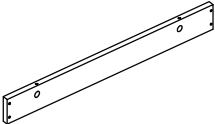
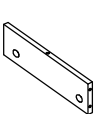
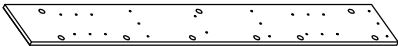
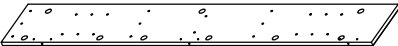
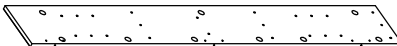
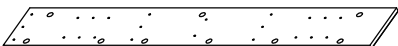
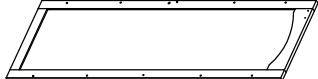
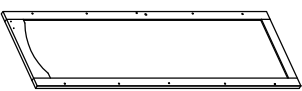





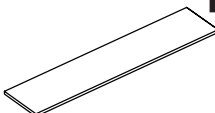

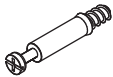

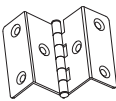
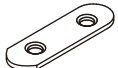
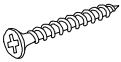

**DE\_** Wenn es sich um eine Massivwand handelt, verwenden Sie bitte Dehnungs- und selbstschneidende Schrauben. Wenn es sich um eine Holzwand handelt, verwenden Sie nur selbstschneidende Schrauben, bitte ziehen Sie die Schrauben nicht zu fest an.

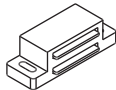
**IT\_** Se si tratta di un muro solido, utilizzare sia viti ad espansione che autofilettanti. Se si tratta di una parete in legno, utilizzare solo viti autofilettanti, non stringere eccessivamente le viti.

**RO\_** Dacă este un perete solid, vă rugăm să utilizați șuruburi cu expansiune și autofiletante, dacă este un perete din lemn, utilizați numai șuruburi autofiletante, vă rugăm să nu strângeți excesiv șuruburile.

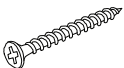

	<b>① x 1</b>		<b>② x 1</b>		<b>③ x 1</b>
	<b>④ x 1</b>		<b>⑤ x 2</b>		<b>⑥ x 2</b>
	<b>⑦ x 2</b>		<b>⑧ x 1</b>		<b>⑨ x 1</b>
	<b>⑩ x 1</b>		<b>⑪ x 1</b>		<b>⑫ x 1</b>
	<b>⑬ x 1</b>		<b>⑭ x 12</b>		<b>⑮ x 4</b>
	<b>⑯ x 6</b>		<b>⑰ x 2</b>		<b>⑱ x 2</b>
	<b>⑲ x 1</b>		<b>⑳ x 2</b>		

 <b>A</b> x44 +1(spare)	 <b>B</b> x44 +1(spare)	 <b>C</b> x62 +1(spare)
 <b>D</b> x42 M3*12 +1(spare)	 <b>E</b> x 6 12mm	 <b>F</b> x 2
 <b>G</b> x 4 M4*30	 <b>H</b> x 4 M3*14	 <b>I</b> x 2
 <b>J</b> x 2 M4*16	 <b>K</b> x 2	 <b>L</b> x24
 <b>Q</b> x16 M2.5*10 +1(spare)	 <b>R</b> x 2	 <b>S</b> x 2
 <b>T</b> x 2 M3.5*40	 <b>U</b> x 4	

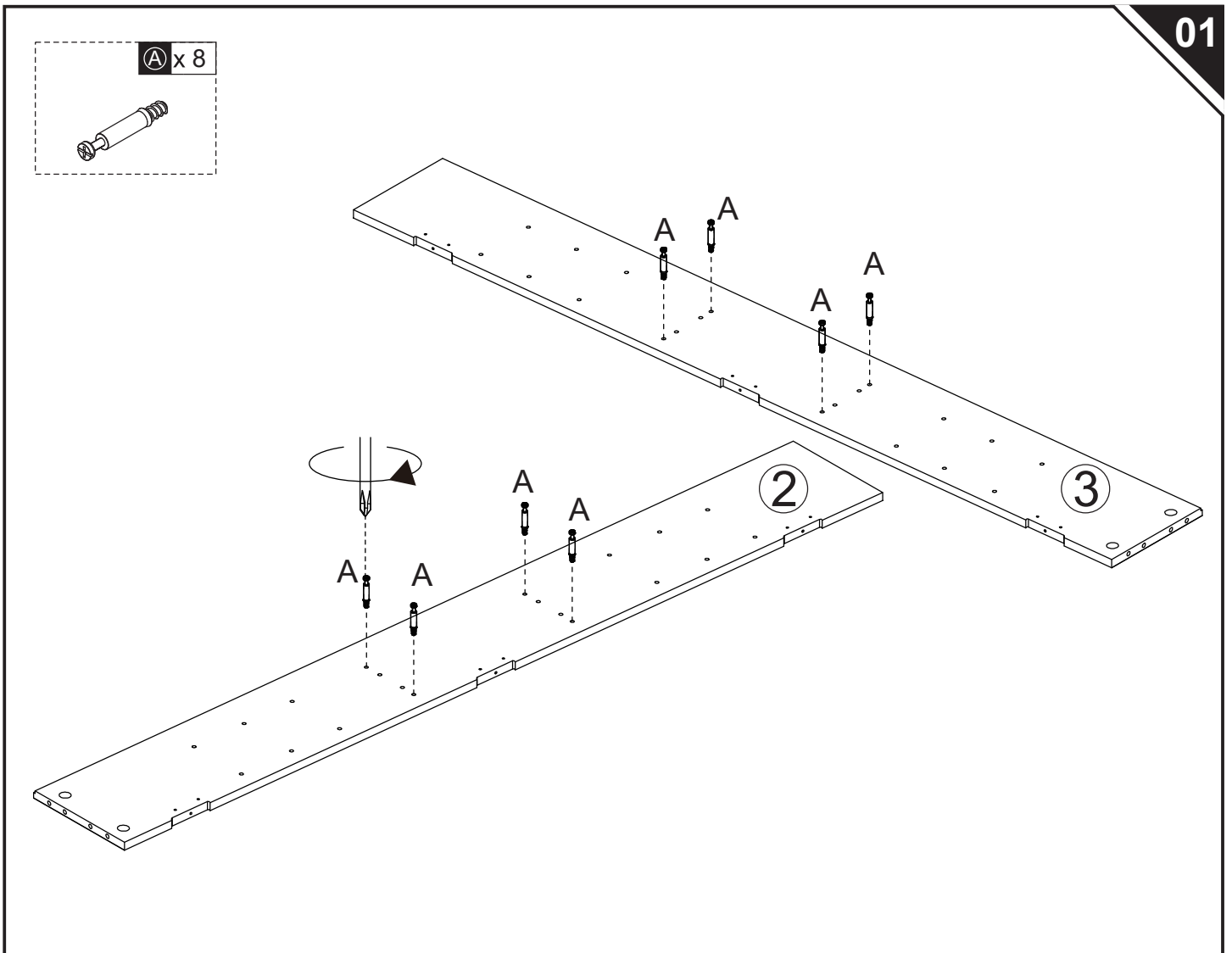

**B** x 4



**C** x 4

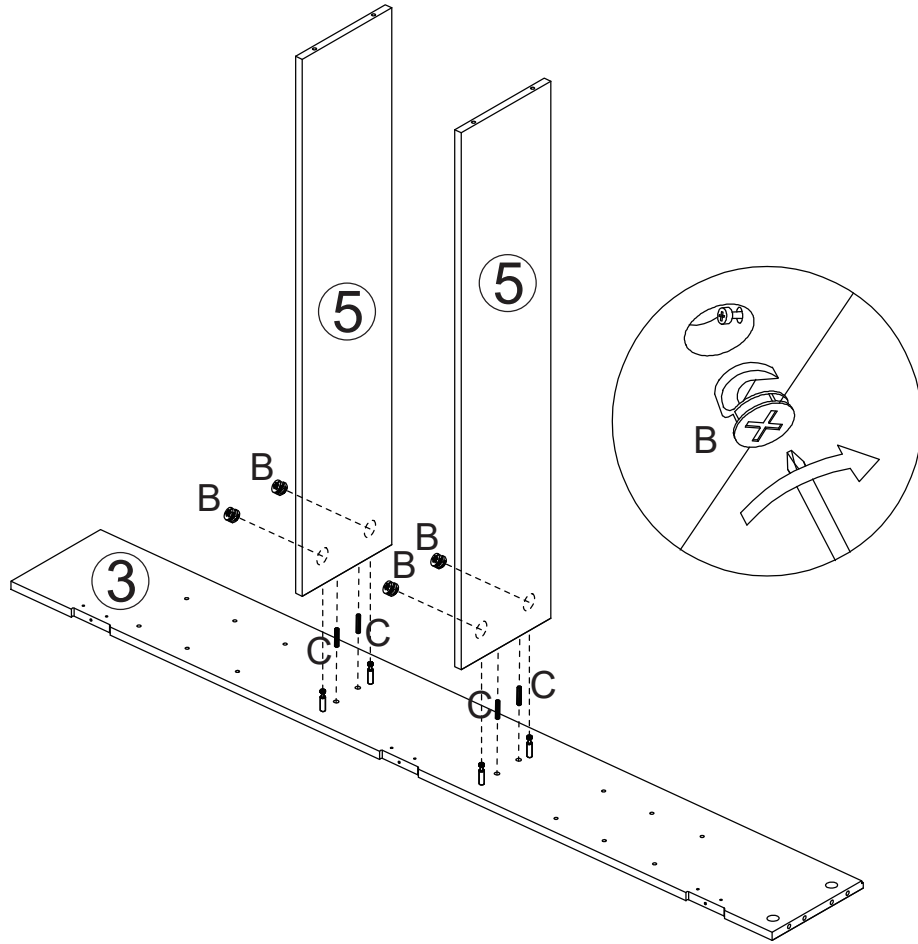

**B** x 4



**C** x 4

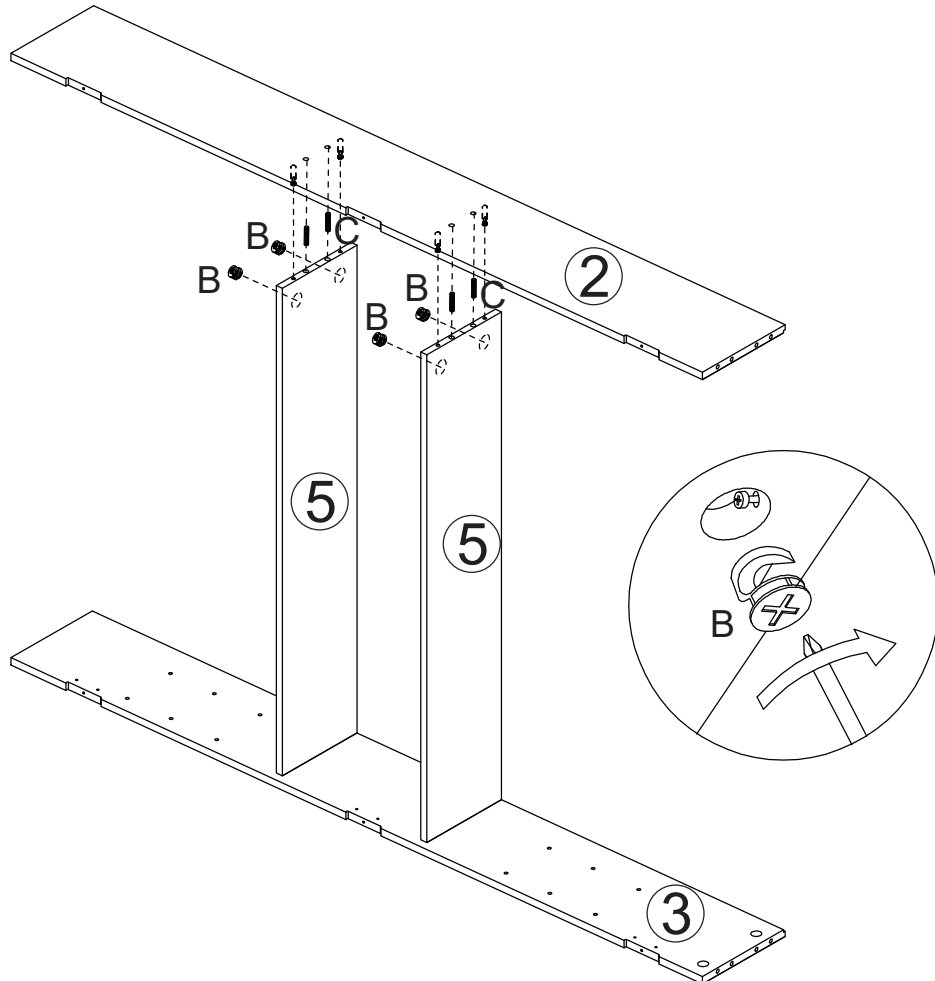

A x 4

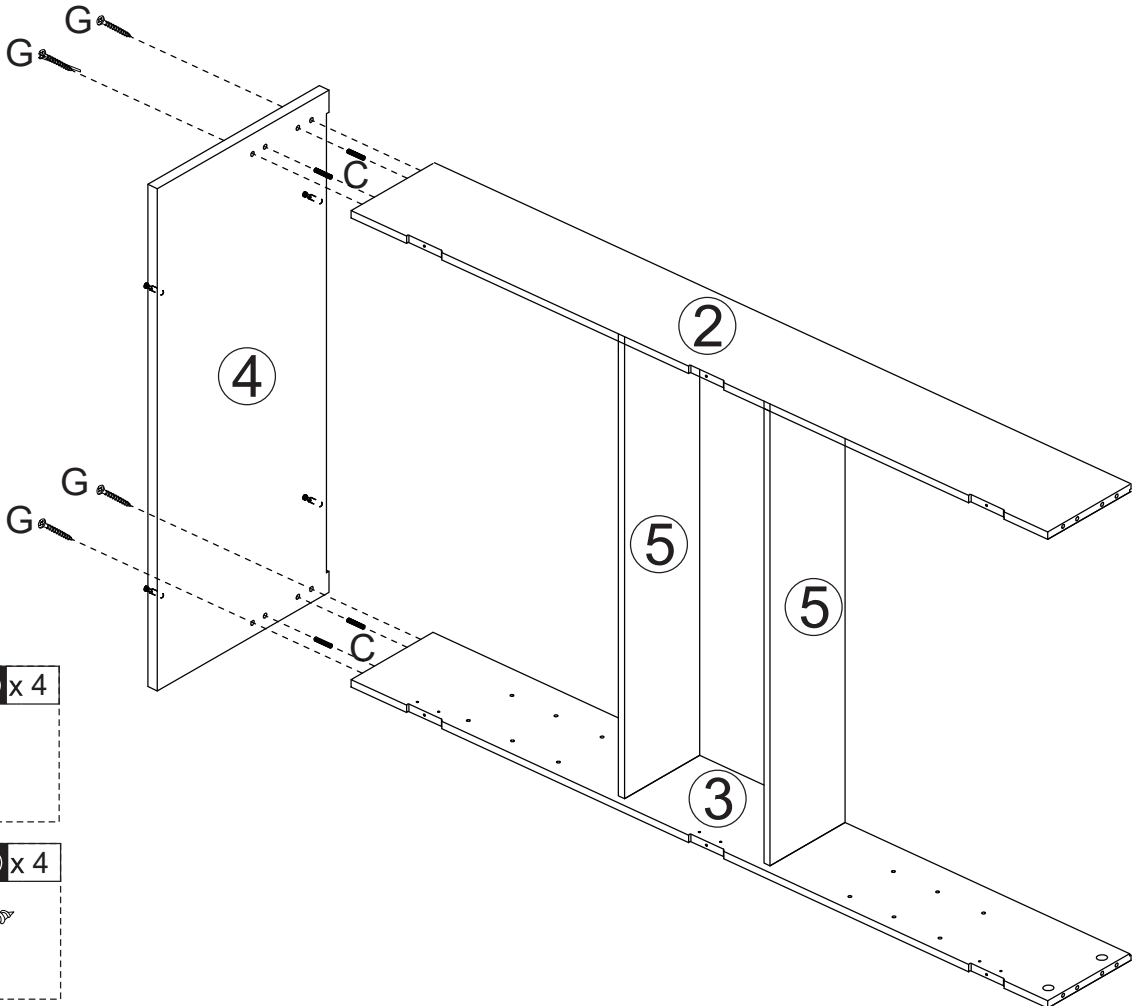
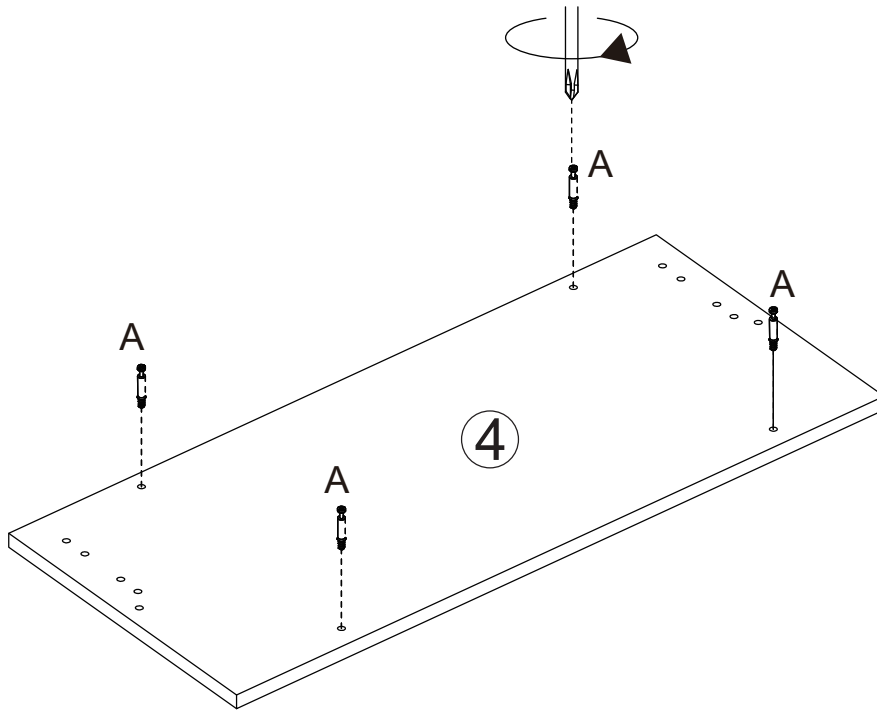
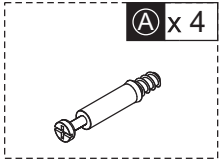

C x 4

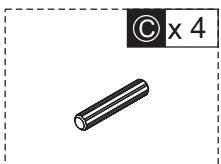

G x 4

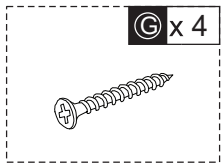

A x 4

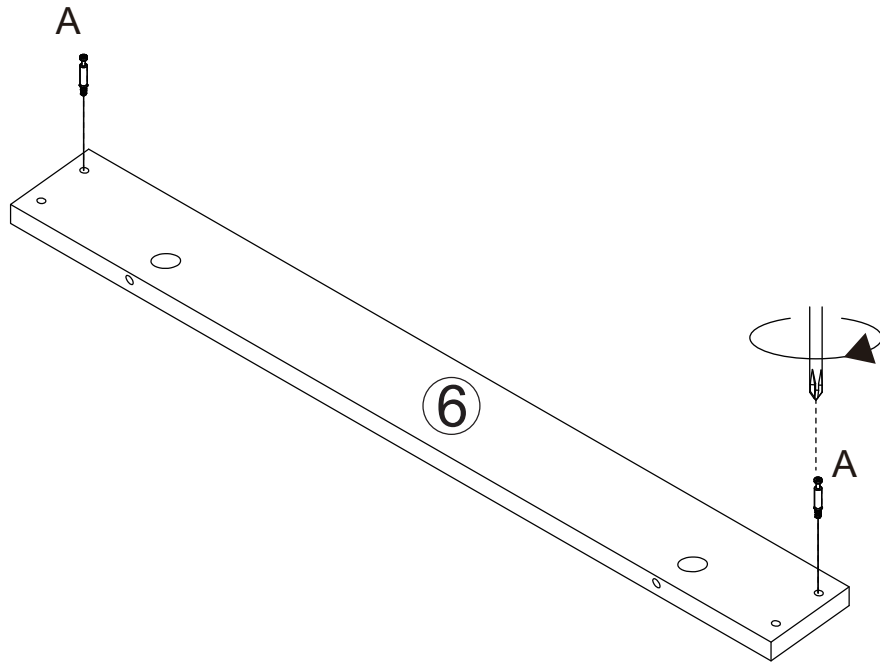
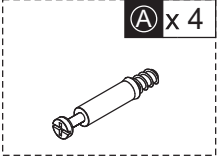

x2

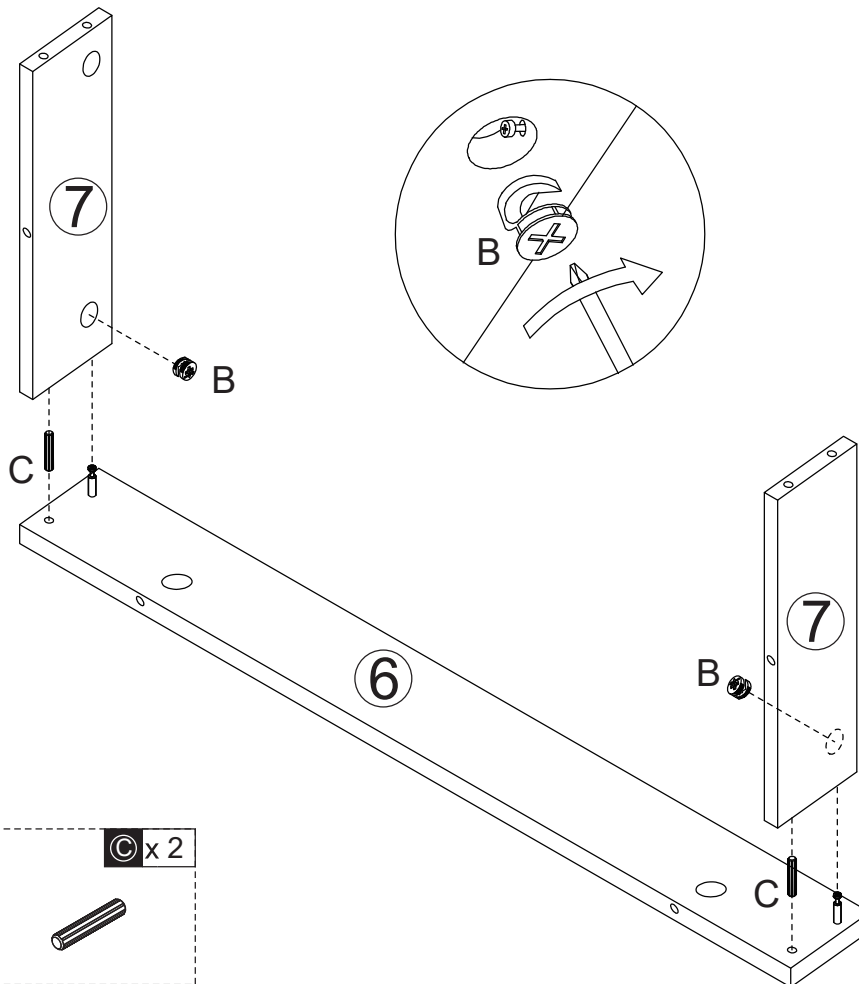

B x 2

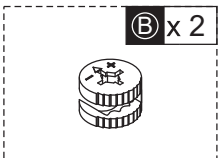

C x 2

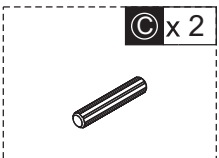

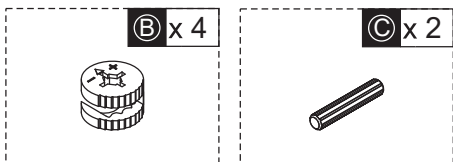
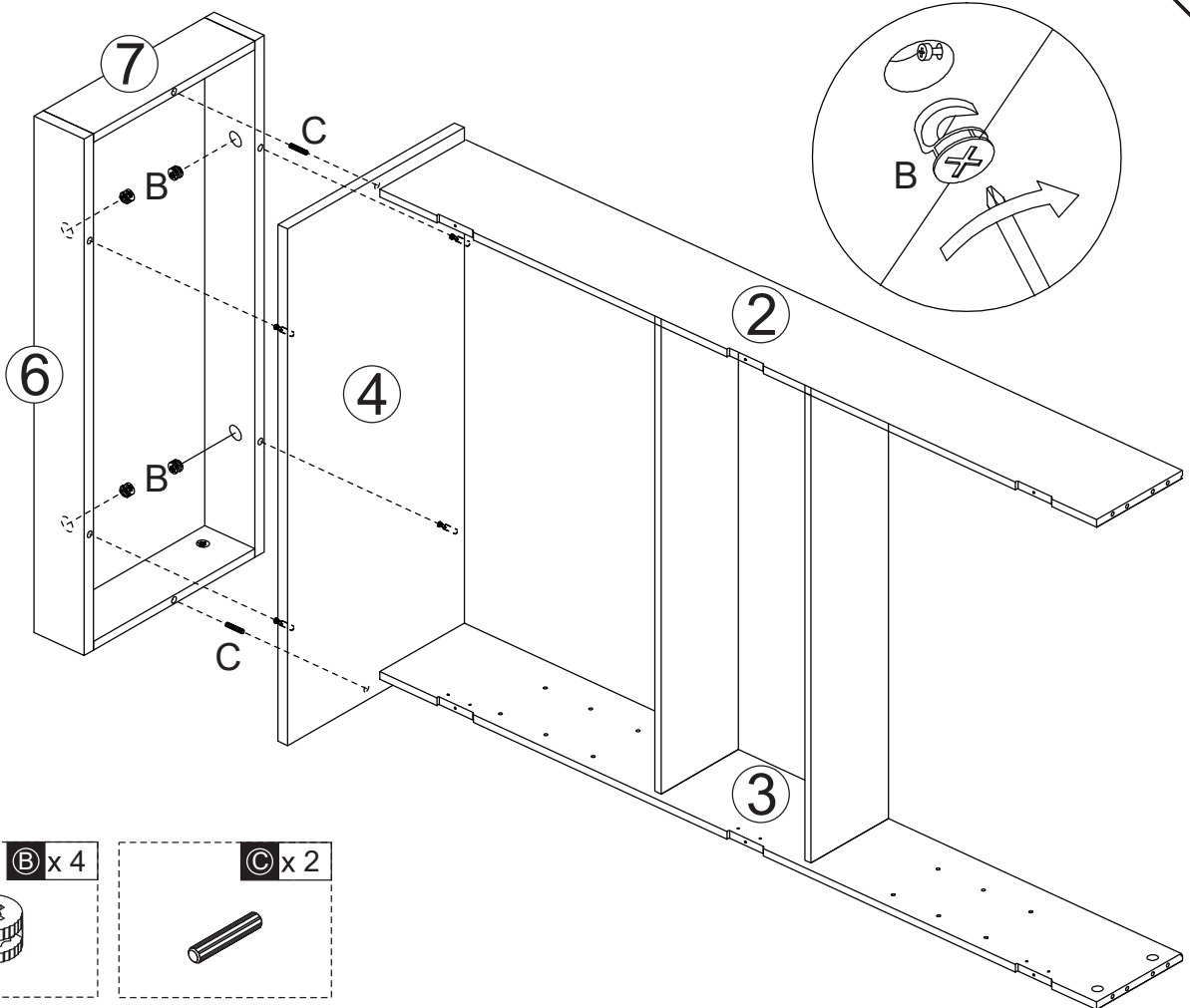
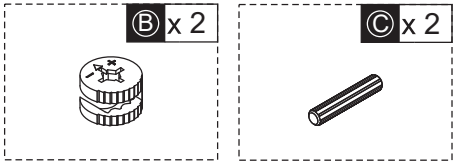
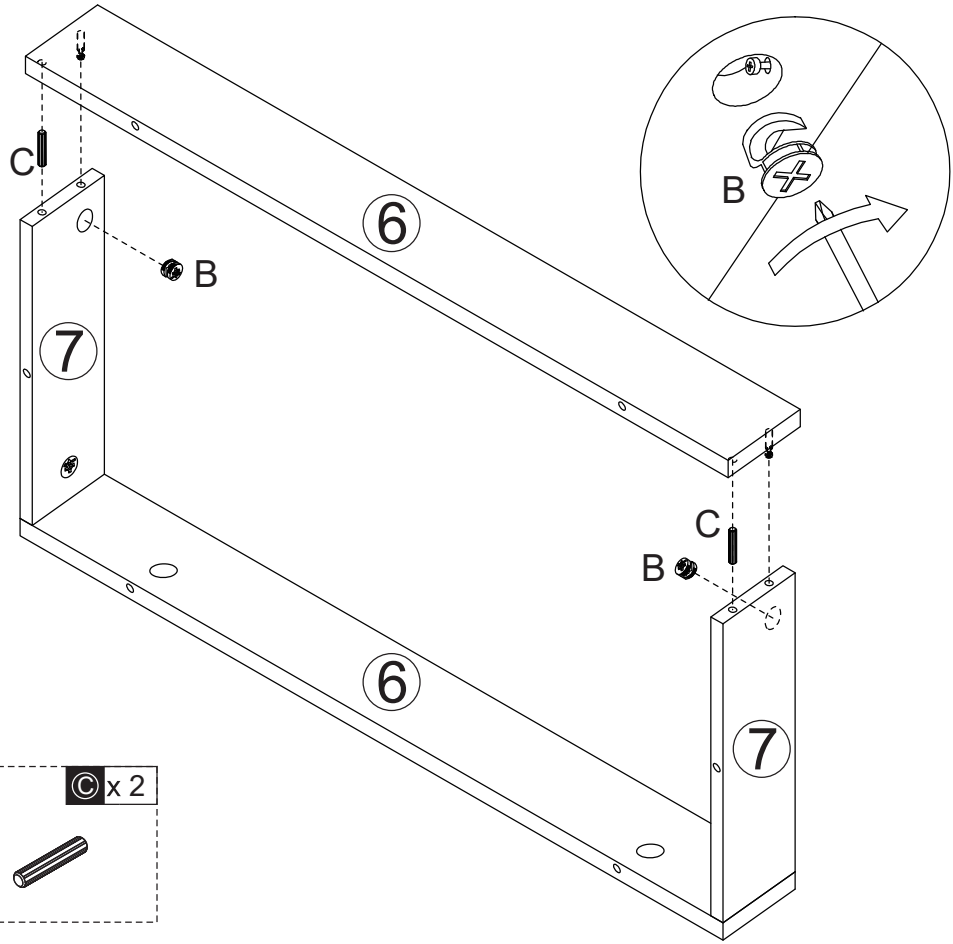

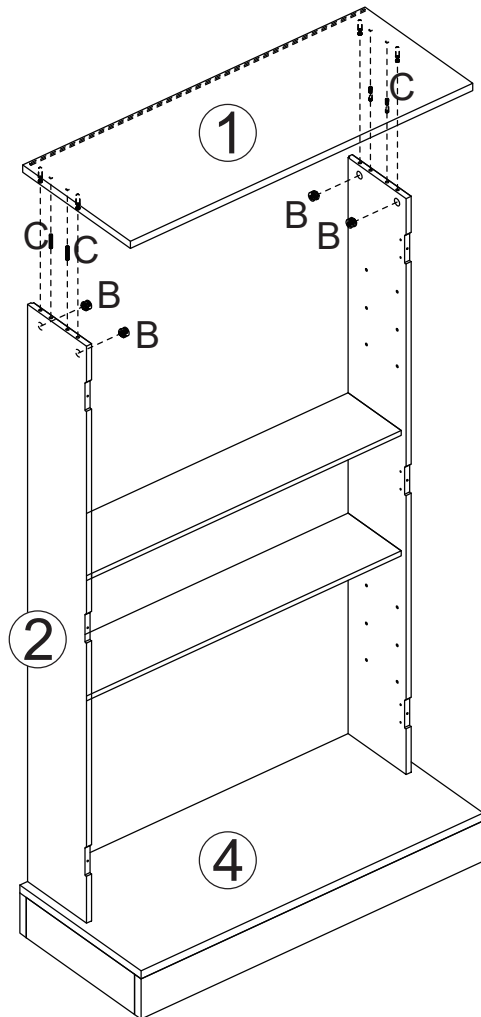
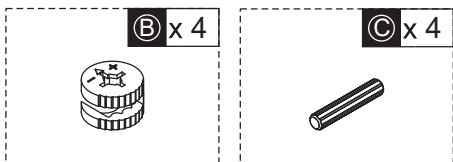
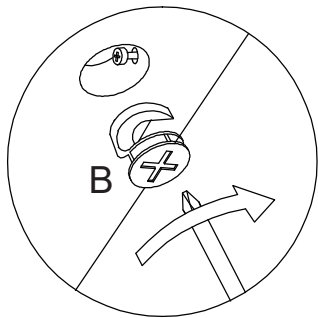
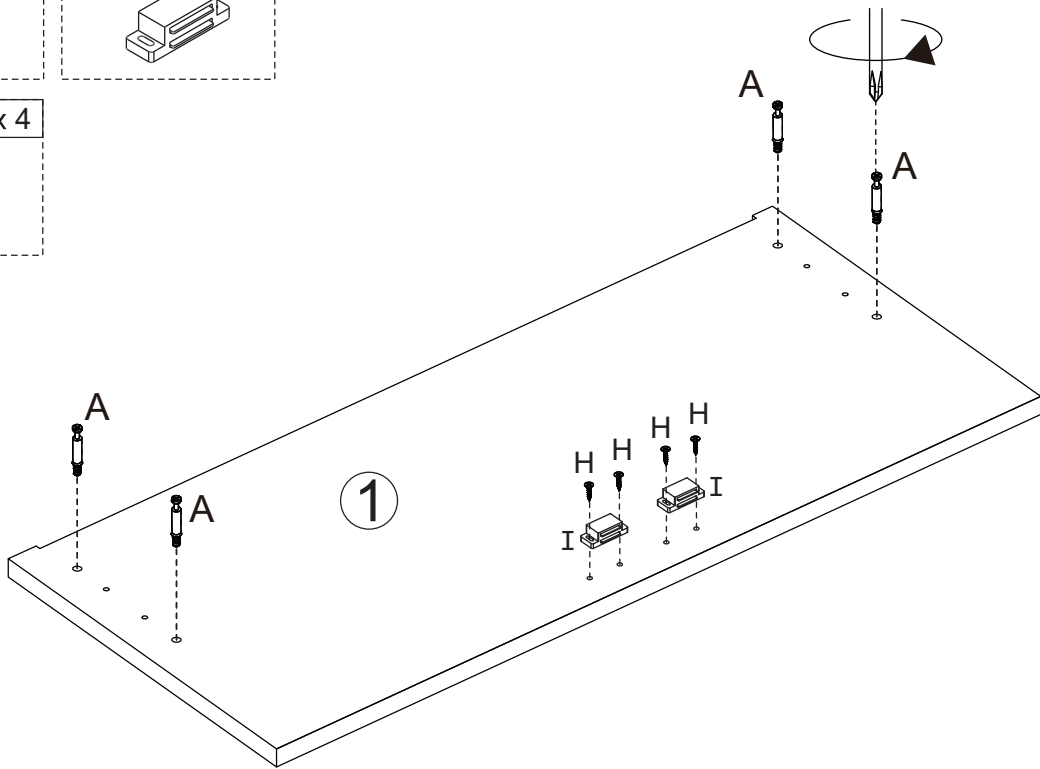
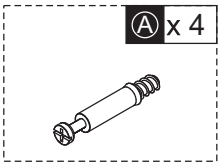
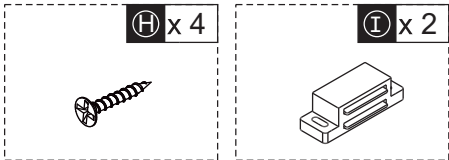

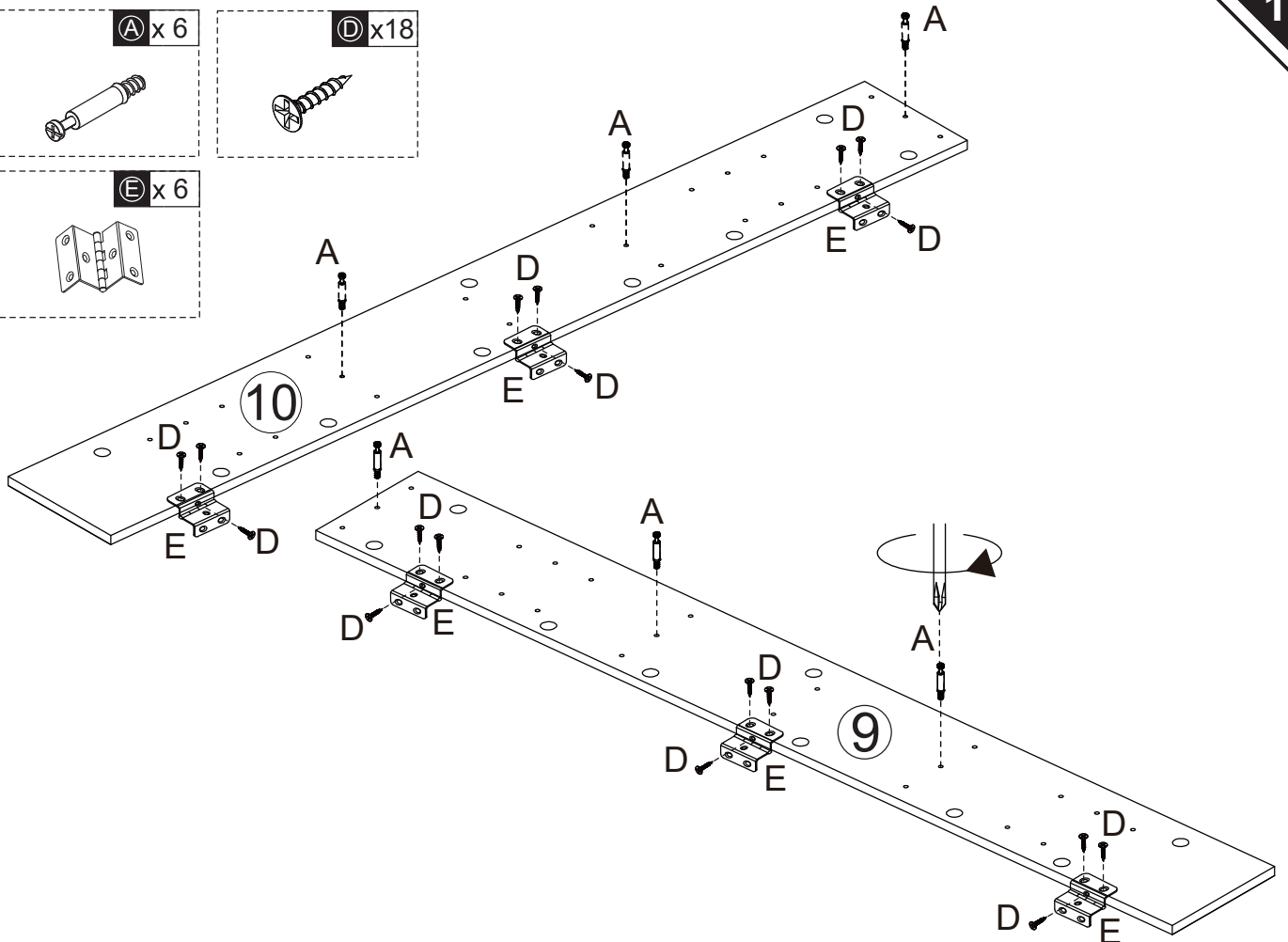
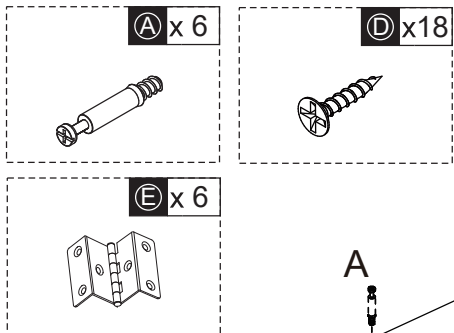
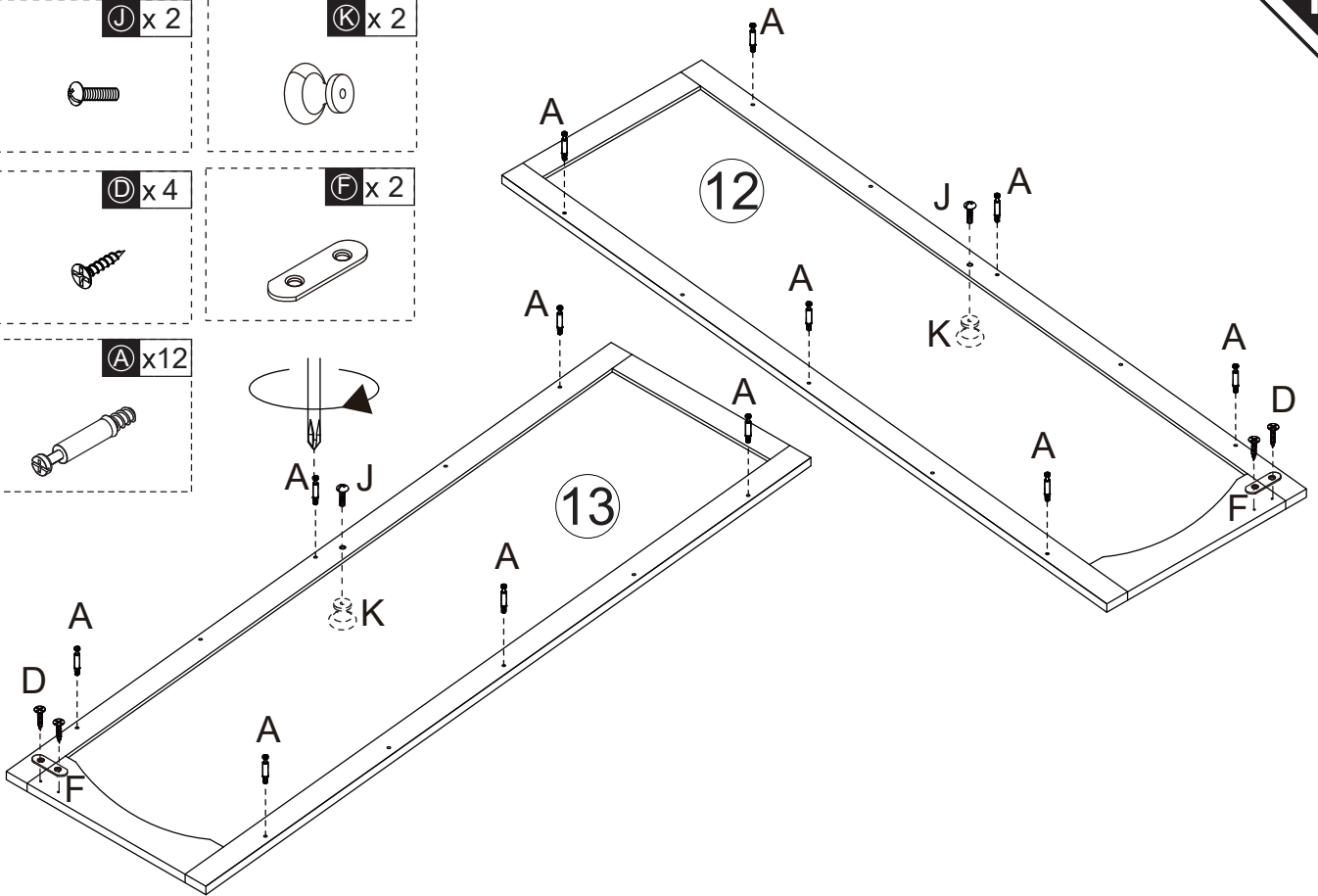
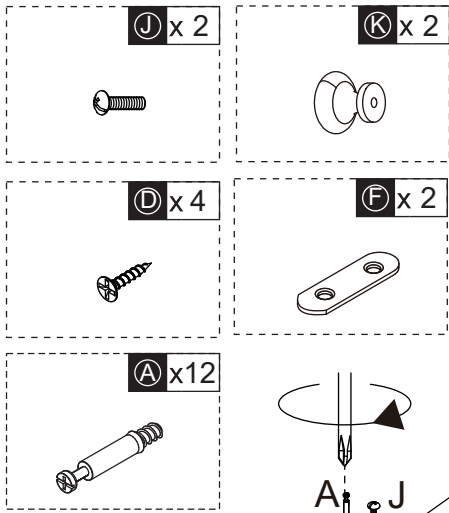

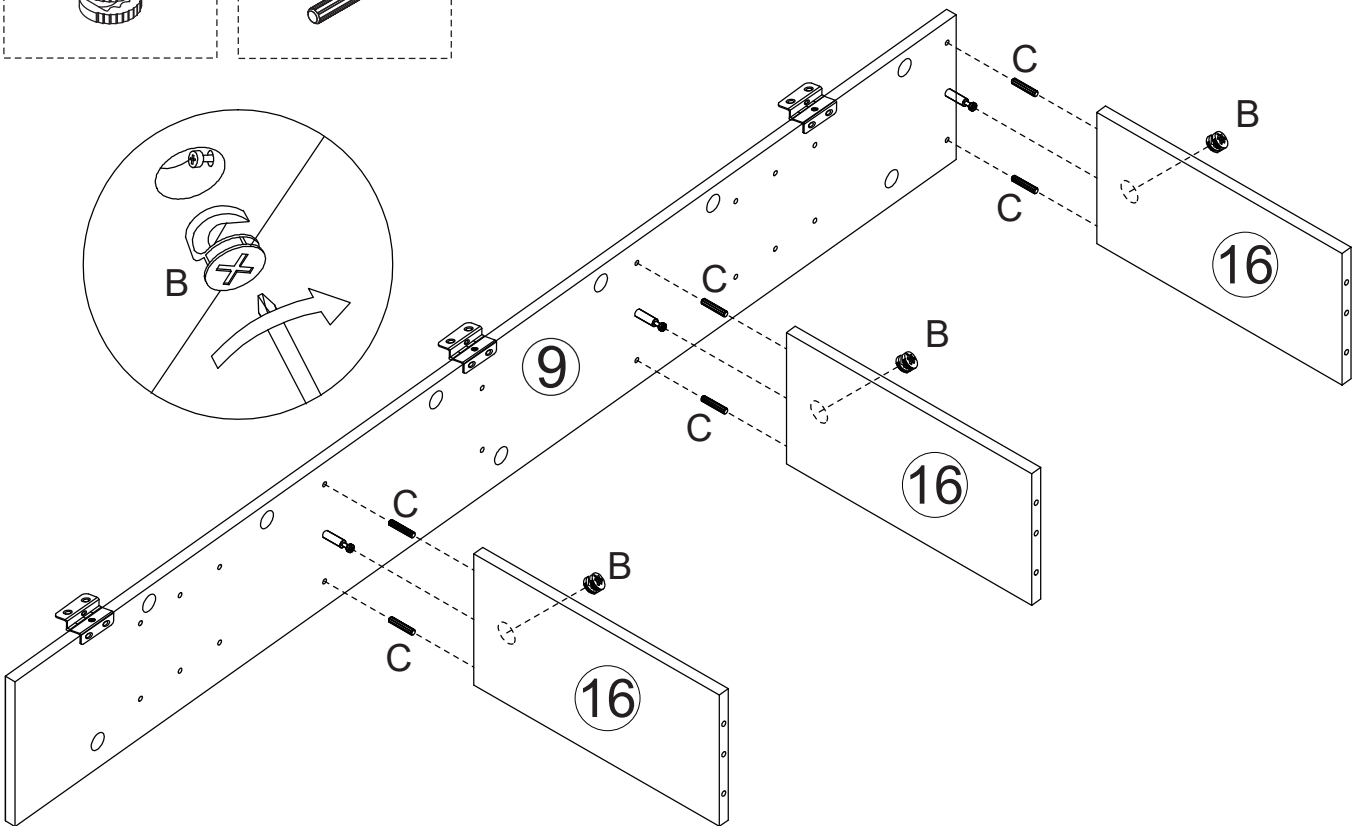
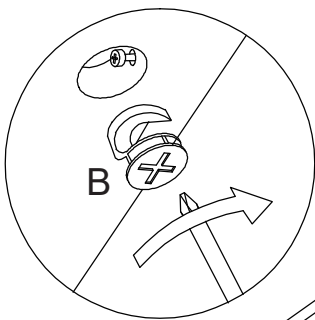
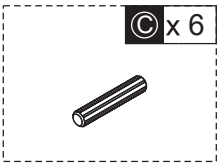
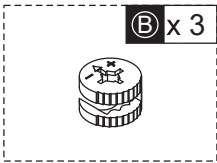
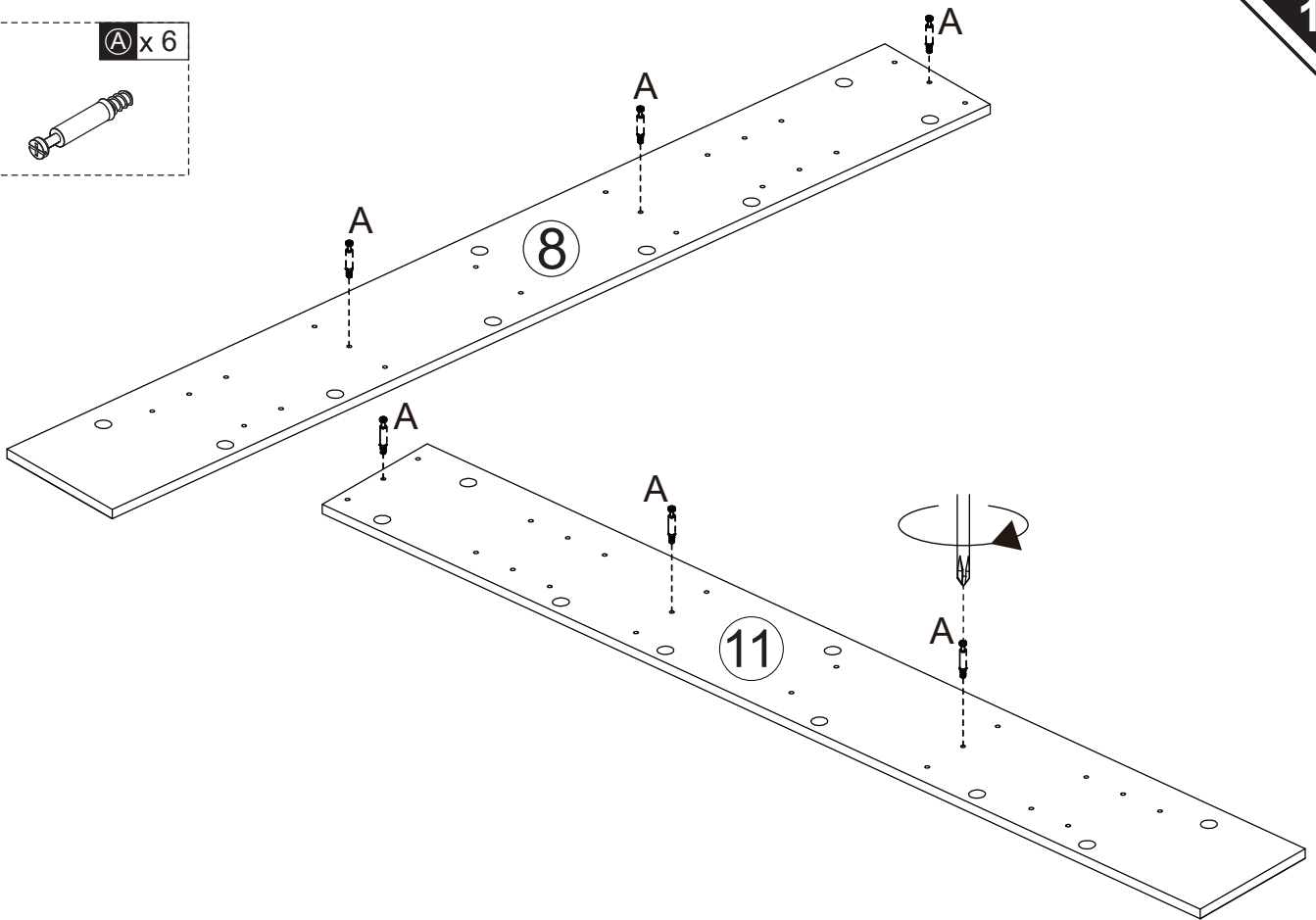
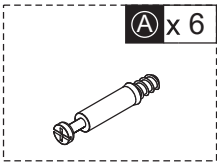

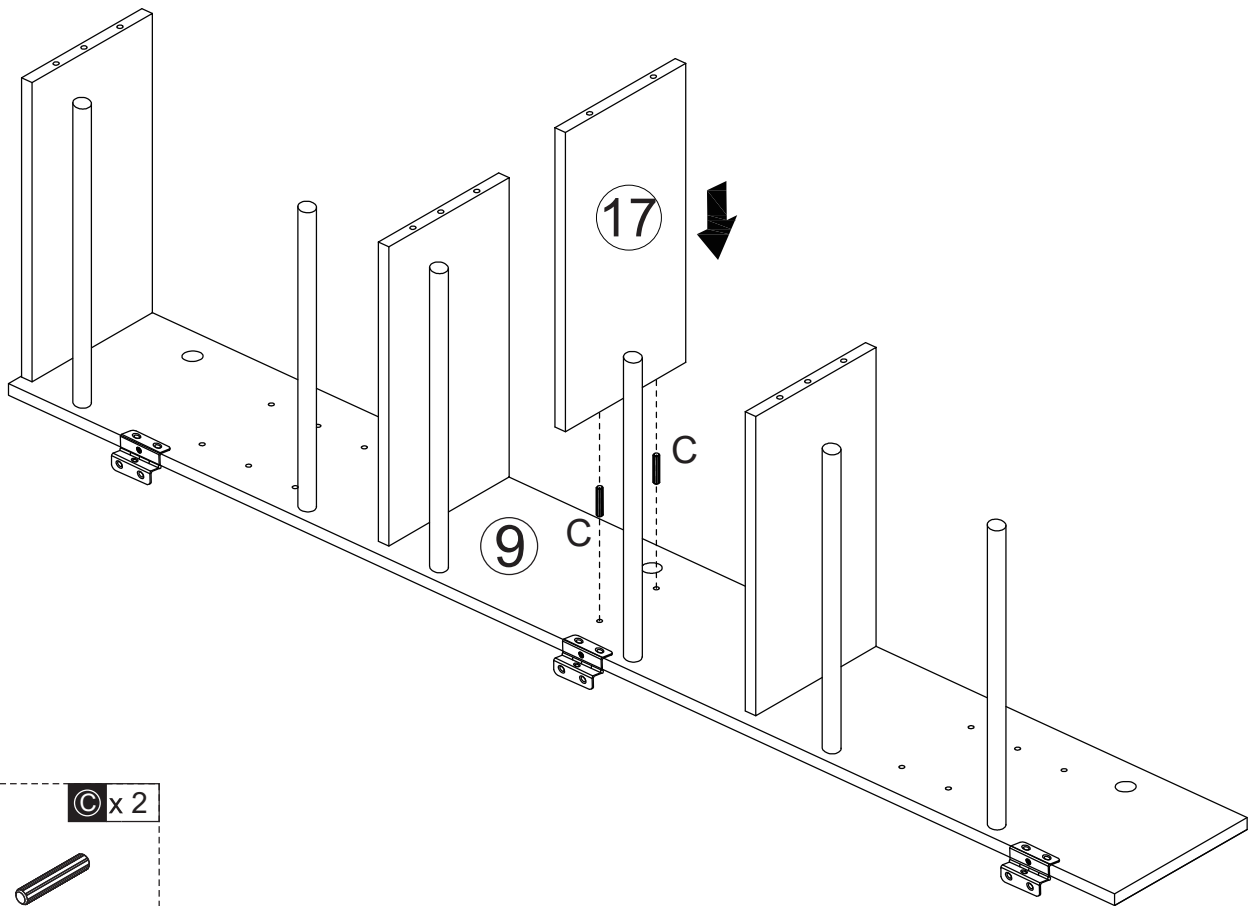
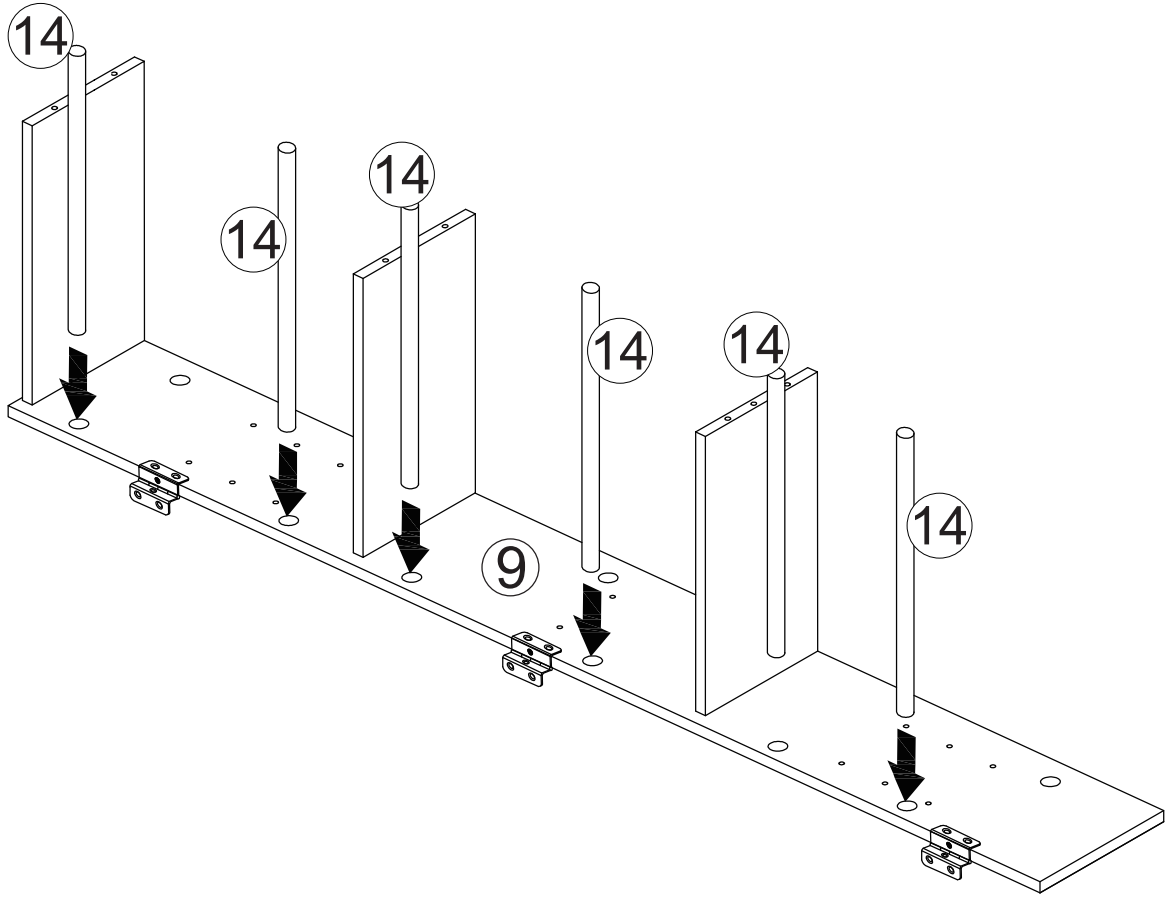

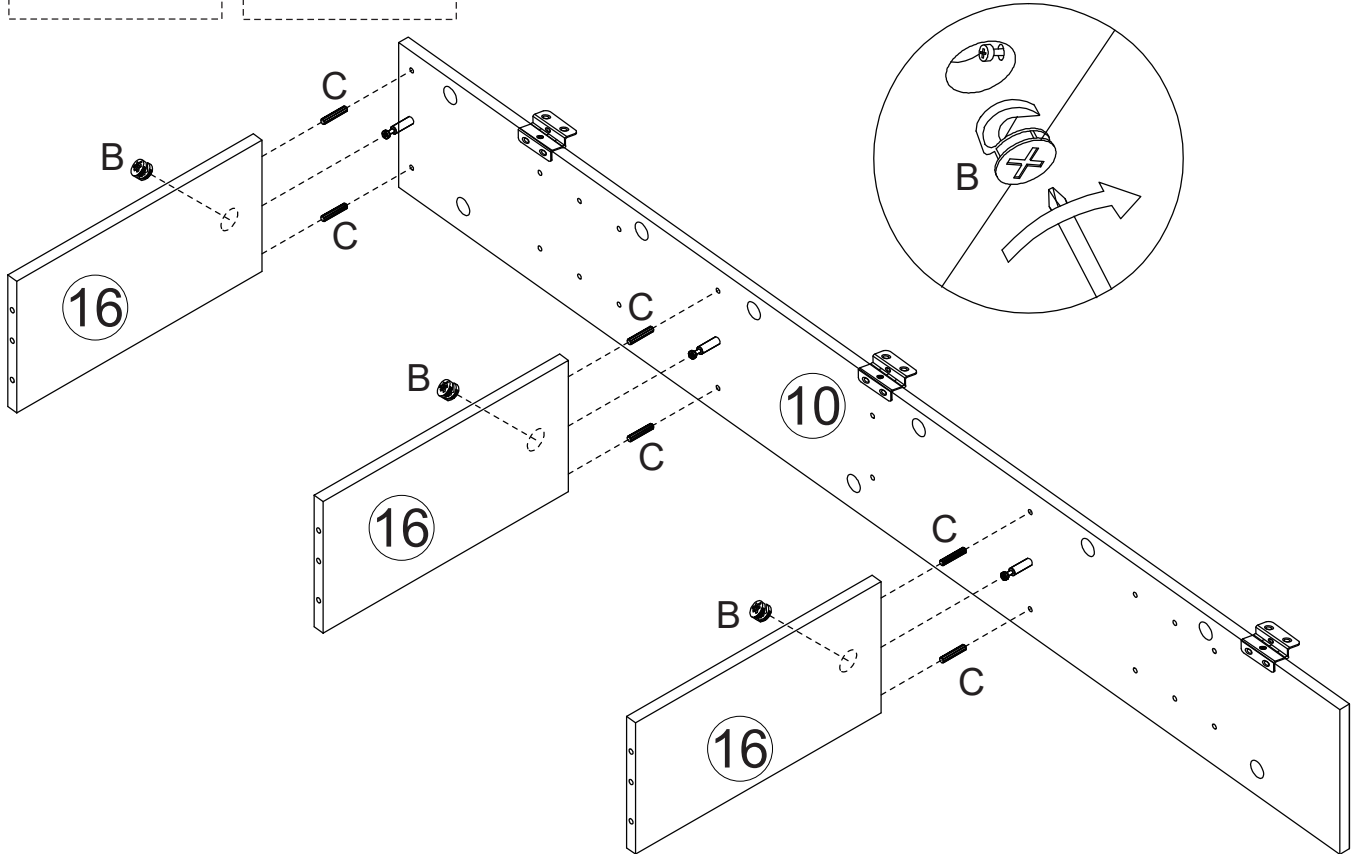
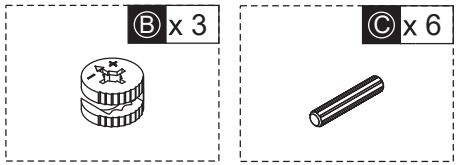
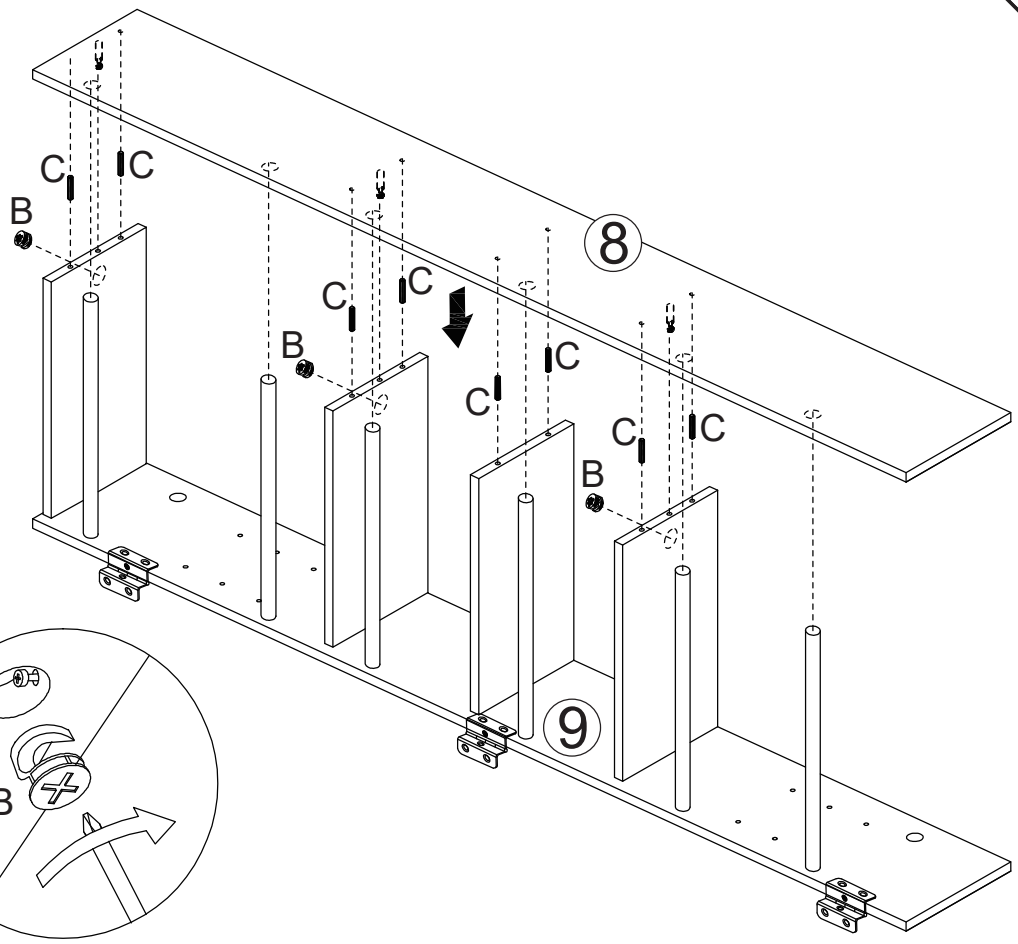
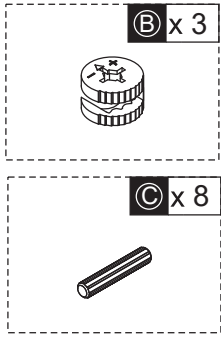

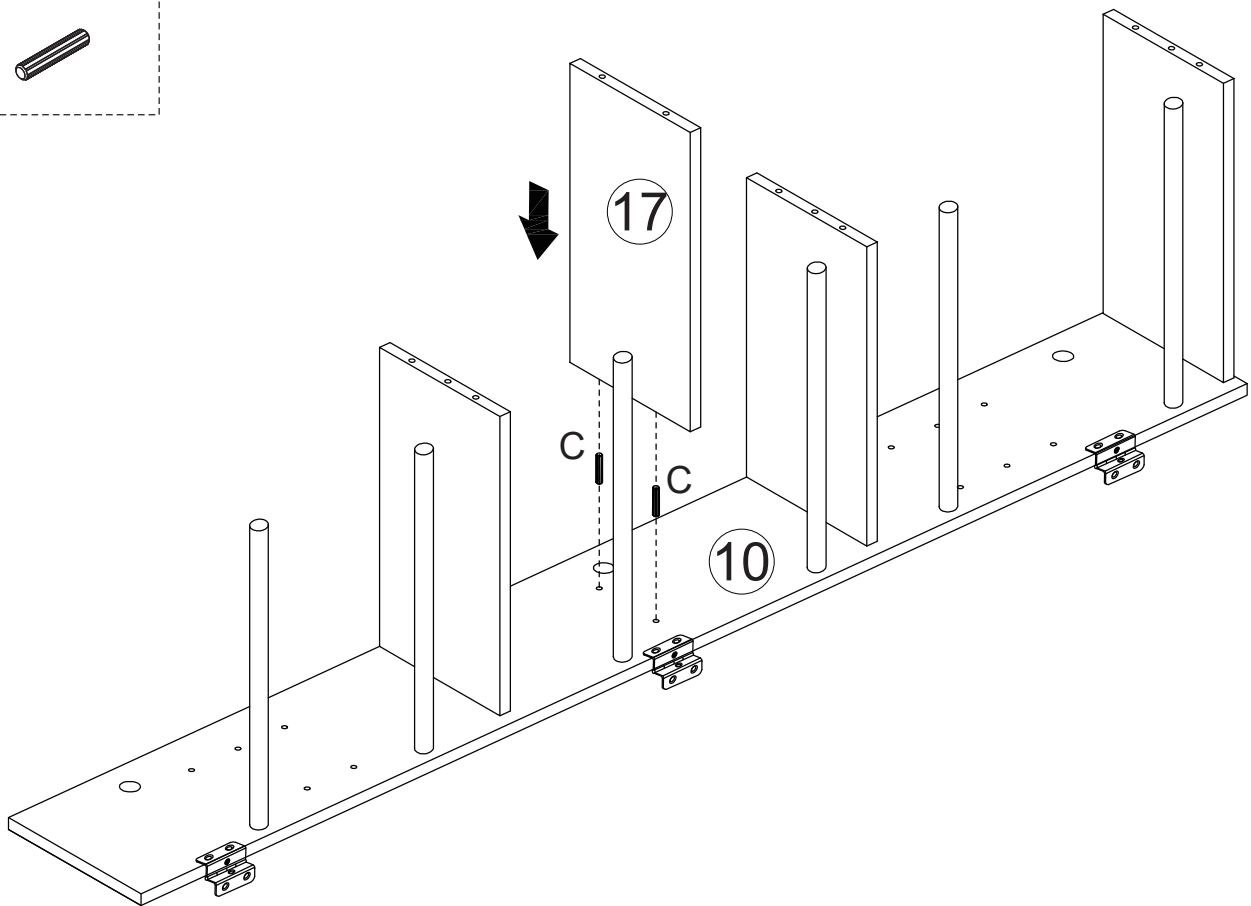
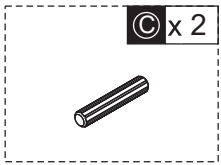
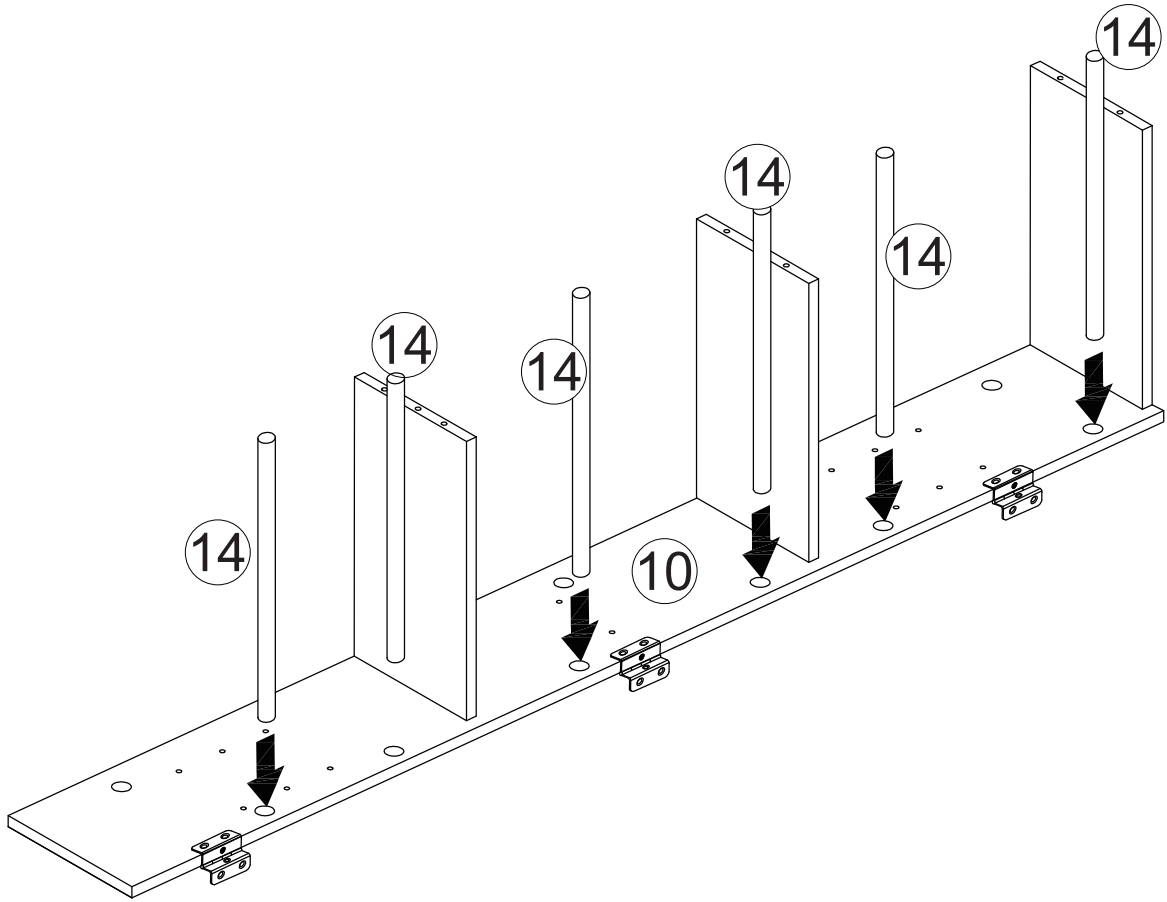

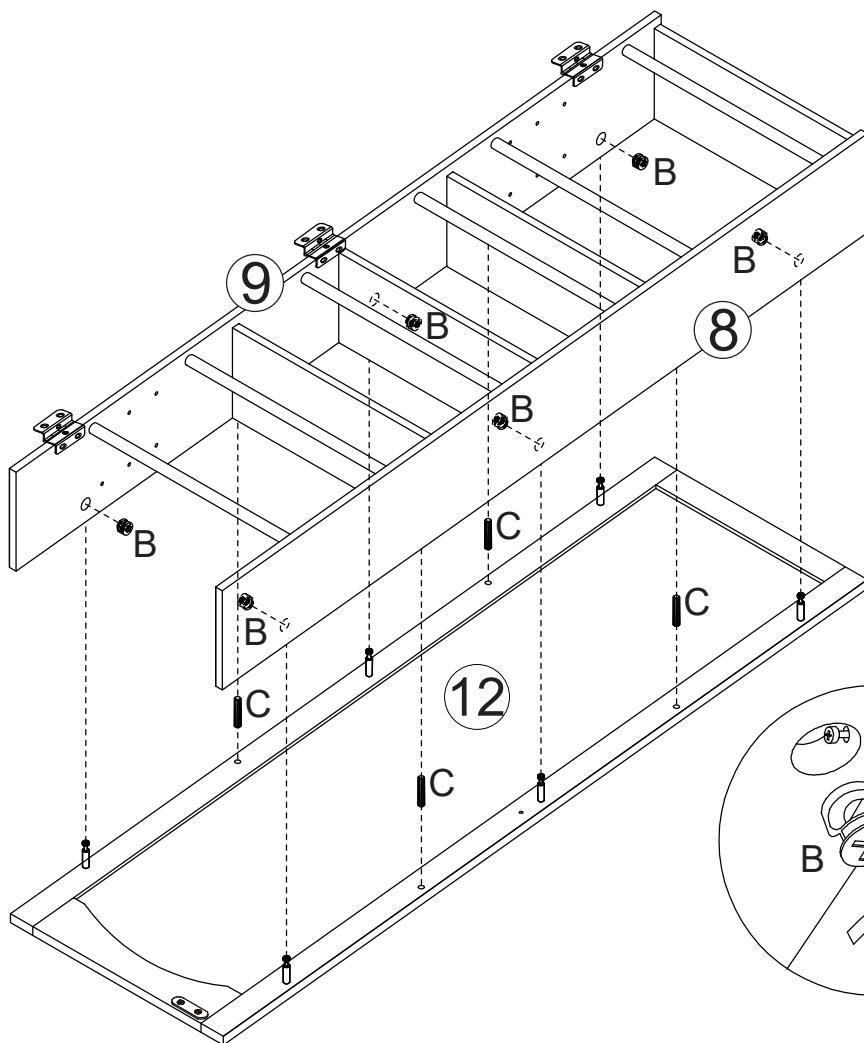
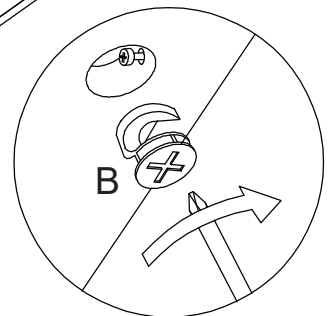
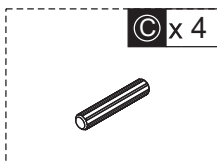
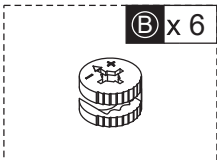
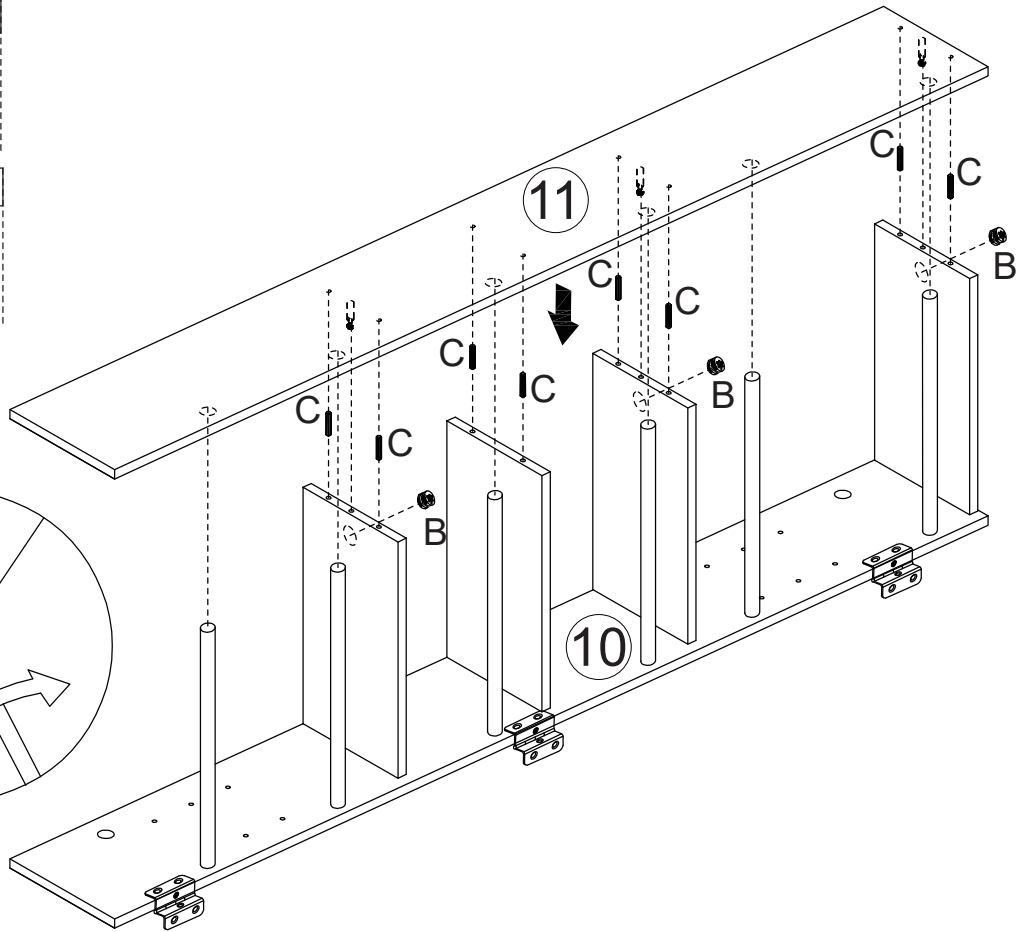
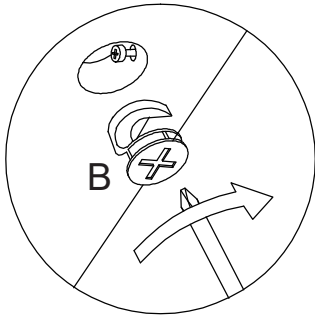
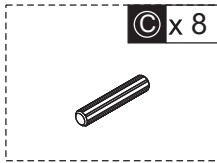
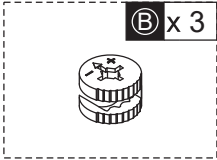

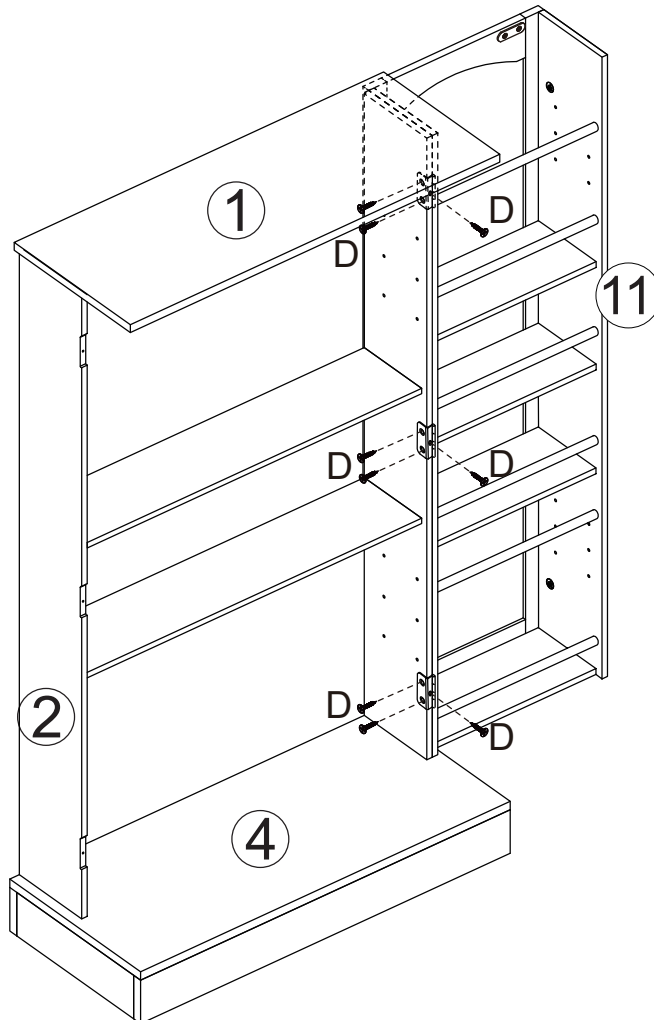
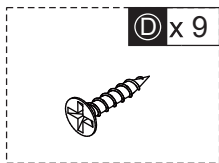
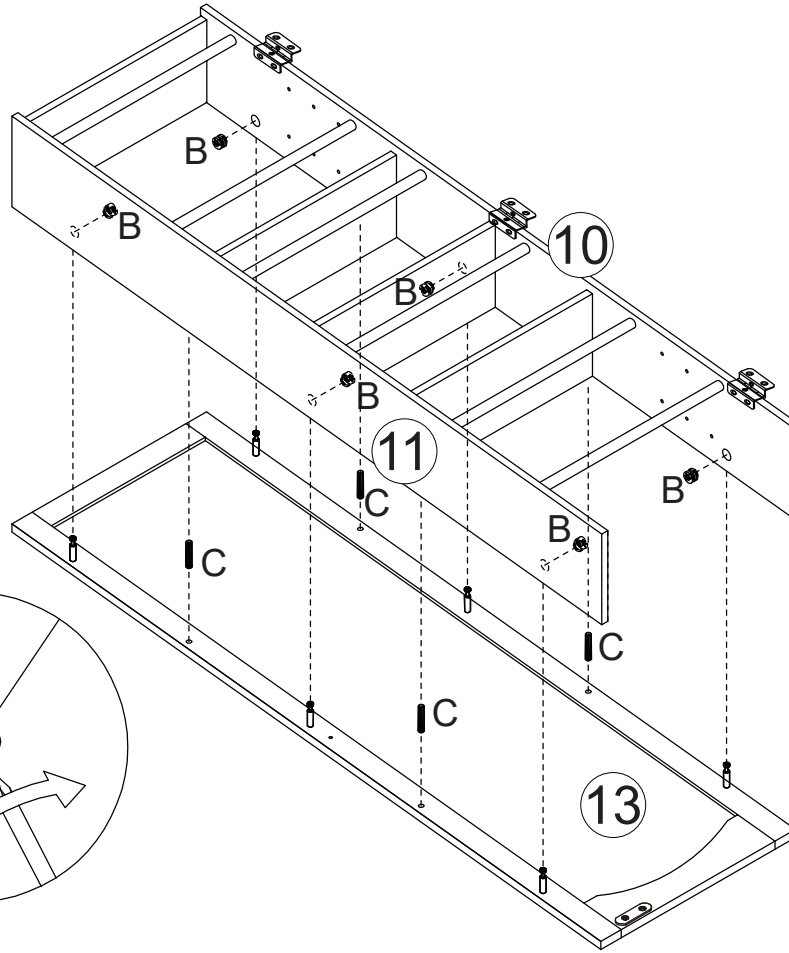
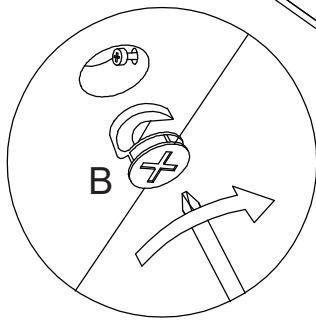
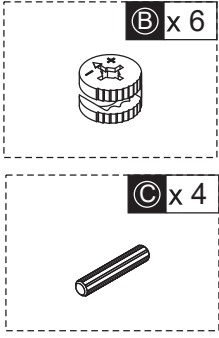

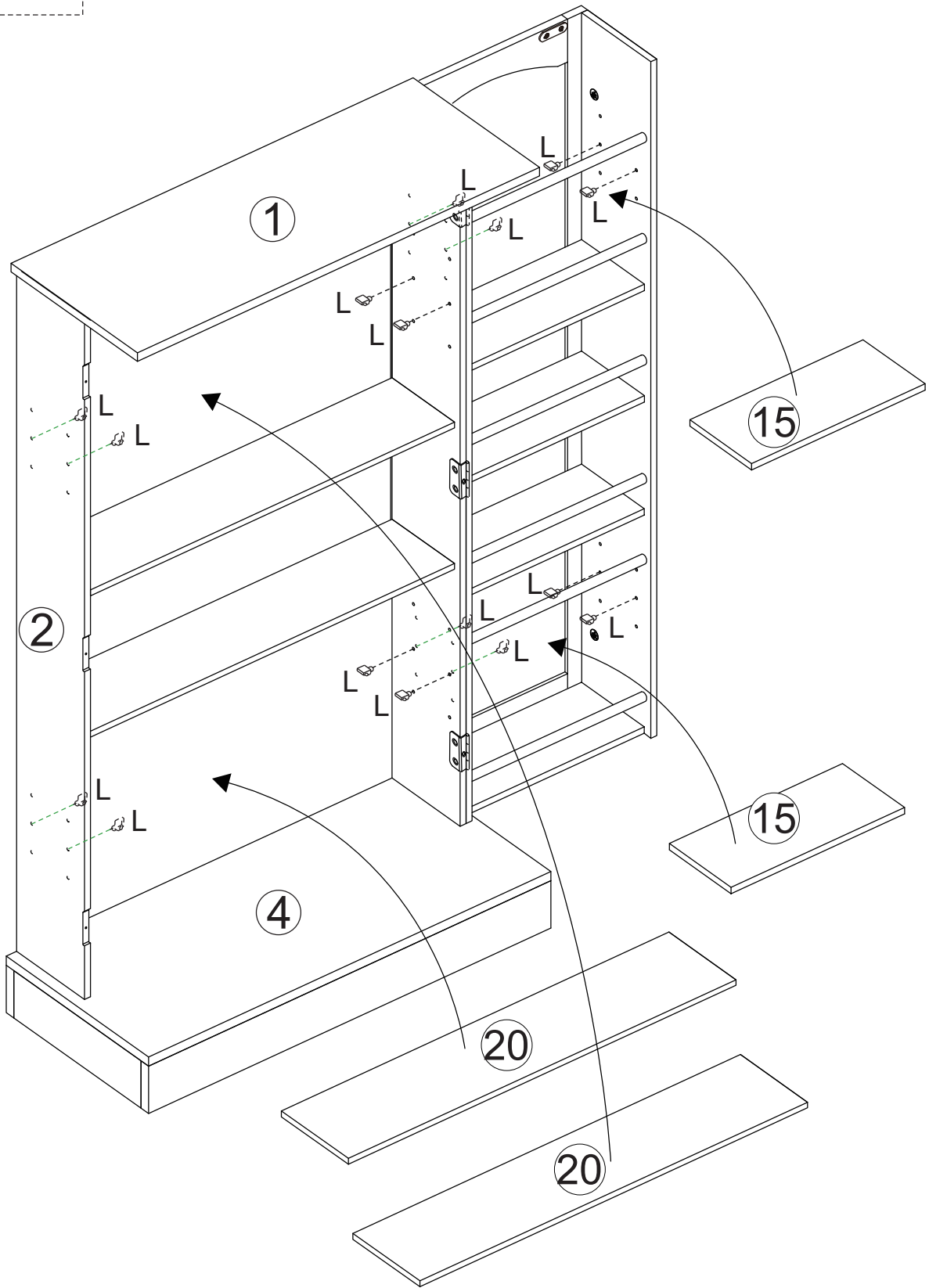
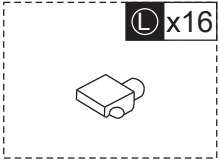

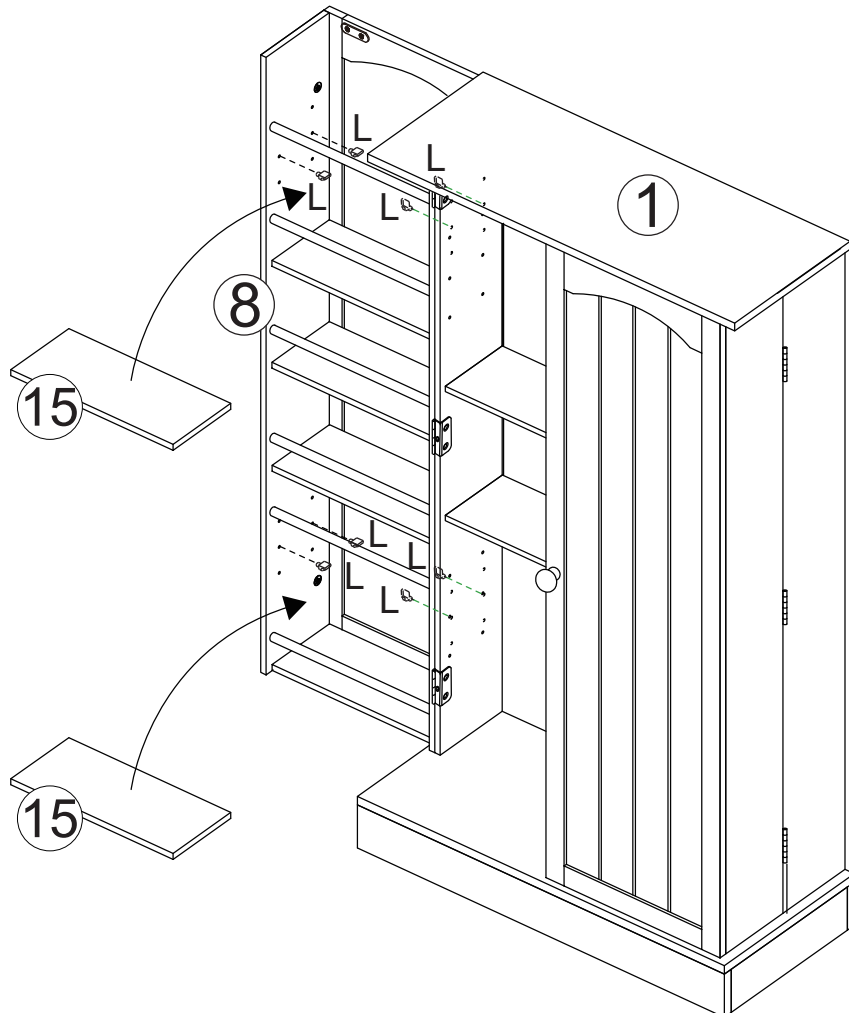
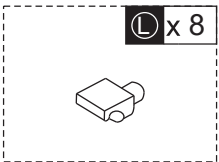
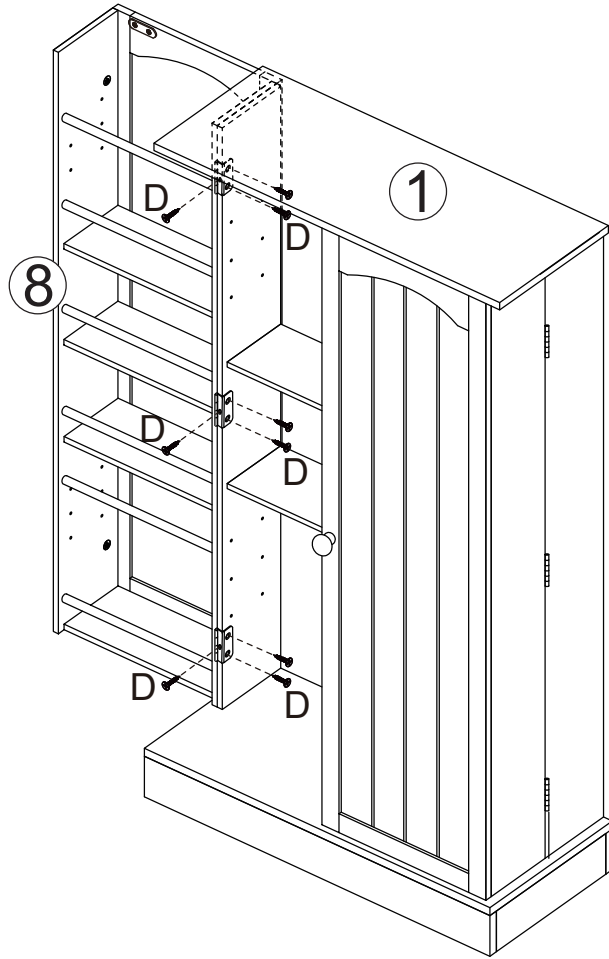
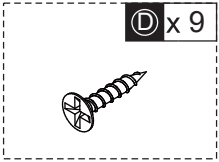



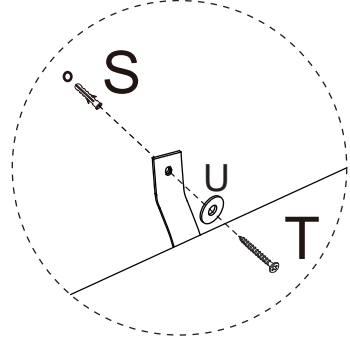
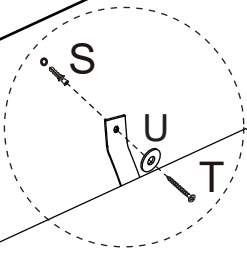
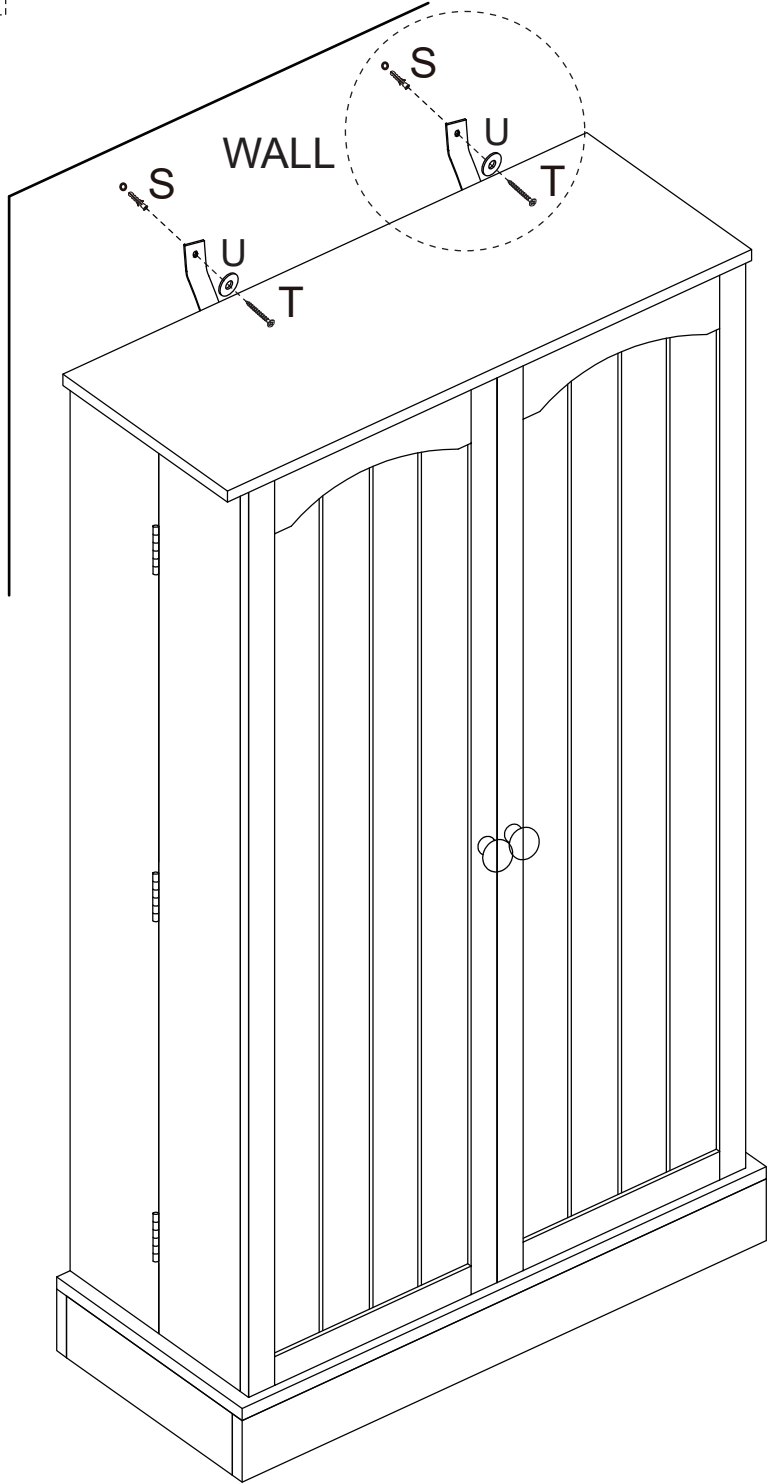
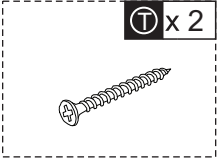
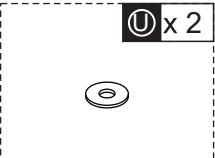
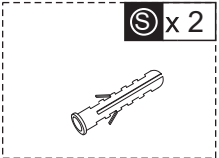

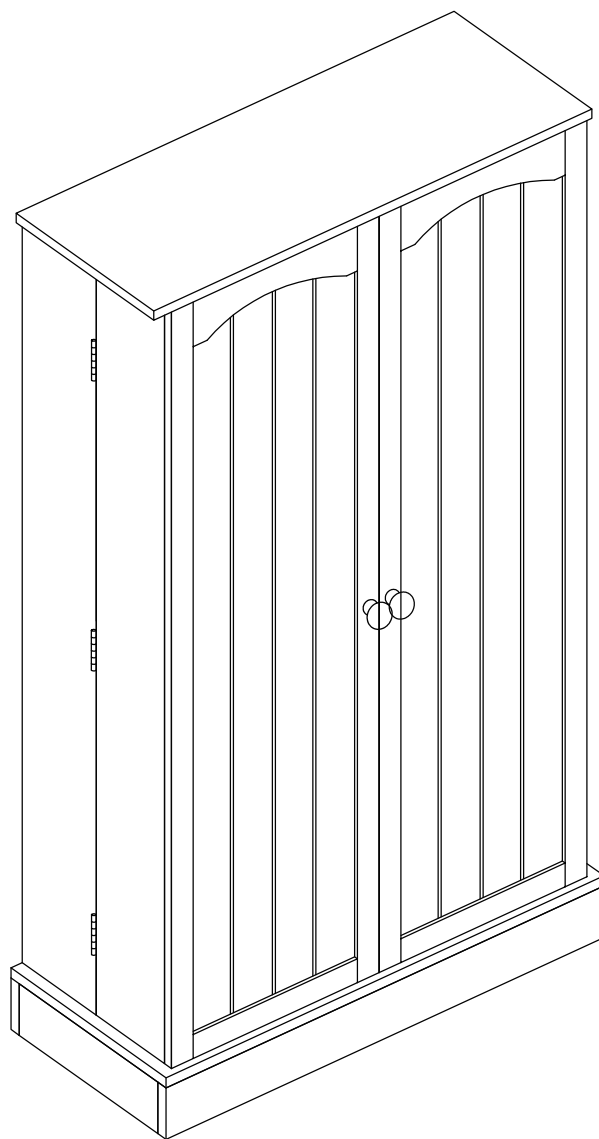



If you have any questions, please contact our customer care center, Our contact details are below:

**US**

 001-877-644-9366

 customerservice@aosom.com

Imported by Aosom LLC  
7777 Center Ave. Suite 430  
Huntington Beach, CA 92647-9998 USA  
MADE IN CHINA

If you have any questions, please contact our customer care center, Our contact details are below:

**CA**

 416-792-6088

 customerservice@aosom.ca

Imported by Aosom Canada Inc.  
7270 Woodbine Avenue, Unit 307, Markham,  
Ontario Canada L3R 4B9  
MADE IN CHINA

Si vous avez la moindre question, veuillez contacter notre centre d'assistance à la clientèle, Nos coordonnées sont les suivantes:

 416-792-6088

 customerservice@aosom.ca

Importé par Aosom Canada Inc.  
7270 Woodbine Avenue, unité 307,  
Markham, Ontario Canada L3R 4B9  
FABRIQUÉ EN CHINE

Si tiene alguna pregunta, comuníquese con nuestro Centro de Atención al Cliente, Nuestros datos de contacto son los siguientes:

**ES**

 0034-931294512

 atencioncliente@aosom.es

IMPORTADOR/Fabricante/REP:  
SPANISH AOSOM, S.L.  
C/ROC GROS, N°15.08550, ELS HOSTALET DE  
BALENYÀ, SPAIN.  
B66295775  
HECHO EN CHINA

Se tiver alguma dúvida, por favor contacte o nosso Centro de Atendimento ao Cliente, Os nossos dados de contacto são os seguintes:

 0034-931294512

 info@aosom.pt.

IMPORTADOR/Fabricante/REP:  
SPANISH AOSOM, S.L.  
C.ROC GROS N.15, 08550. ELS HOSTALET DE  
BALENYÀ  
FEITO NA CHINA

In caso di dubbio, si prega di contattare il nostro centro assistenza clienti, I nostri dettagli di contatto sono di seguito:

**IT**

 0039-0249471447

 clienti@aosom.it

IMPORTATO DA/Produttore/REP:  
AOSOM Italy srl  
Centro Direzionale Milanofiori  
Strada 1 Palazzo F1  
20057 Assago (MI)  
P.I.: 08567220960  
FATTO IN CINA

If you have any questions, please contact our customer care center, Our contact details are below:

**UK**

 0044-800-240-4004

 enquiries@mhstar.co.uk

IMPORTER ADDRESS:  
MH STAR UK Ltd  
1 Northampton Cross Logistics Park  
Northampton Cross Road  
Northampton  
NN4 9FH  
MADE IN CHINA

Wenn Sie Fragen haben, wenden Sie sich bitte an unser Kundendienstzentrum, Unsere Kontaktdaten stehen unten:

**DE**

 0049-0(40)-87408465

 service@aosom.de

ADRESSE DES IMPORTEURE/Hersteller/REP:  
MH Handel GmbH  
Wendenstraße 309  
D-20537 Hamburg  
Germany  
IN CHINA HERGESTELLT

Si vous avez la moindre question, veuillez contacter notre centre d'assistance à la clientèle, Nos coordonnées sont les suivantes:

**FR**

 0033-1-84166106

 aosom@mhfrance.fr

Importé par/Fabricant/REP:  
MH FRANCE  
2 Rue Maurice Hartmann  
92130 Issy Les Moulineaux  
France  
FABRIQUÉ EN CHINE



**FR**

**DONNEZ  
OU  
RECYCLEZ**



ASSOCIATION

OU



LIVRAISON

OU



DÉCHÈTERIE

Adresses sur [quefairedemesdechets.fr](http://quefairedemesdechets.fr)