

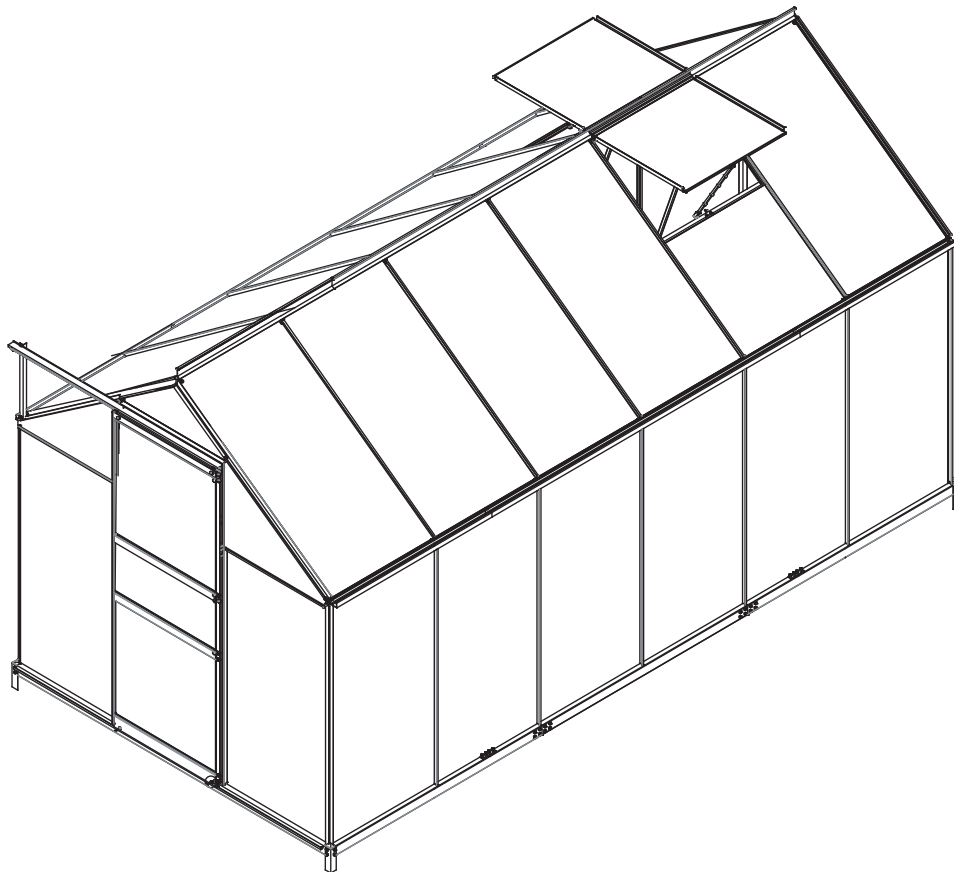

IN230400198V03

**845-540V02****21**  
STEPS

5 HR

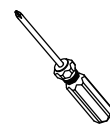
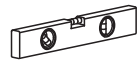
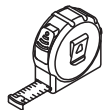
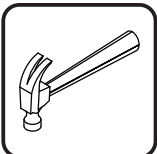
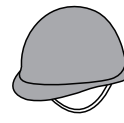

Tools Recommended

**EN\_ IMPORTANT, RETAIN FOR FUTURE REFERENCE: READ CAREFULLY.**

**FR\_ IMPORTANT: A LIRE ATTENTIVEMENT ET À CONSERVER POUR CONSULTATION ULTÉRIEURE.**

**ES\_ IMPORTANTE, LEA Y GUARDE PARA FUTURAS REFERENCIAS.**

**PT\_ IMPORTANTE: LEIA ATENTAMENTE E GUARDE PARA CONSULTA FUTURA.**

**DE\_ WICHTIG! SORGFÄLTIG LESEN UND FÜR SPÄTER NACHSCHLAGEN AUFBEWAHREN.**

**IT\_ IMPORTANTE! CONSERVARE IL PRESENTE MANUALE PER FUTURO RIFERIMENTO E LEGGERLO ATTENTAMENTE.**

**RO\_ IMPORTANT: CITIȚI CU ATENȚIE ȘI PĂSTRAȚI PENTRU CONSULTARE VIITOARE.**

**TO PREVENT INJURY, READ AND UNDERSTAND THE GREENHOUSE ASSEMBLY INSTRUCTIONS BEFORE USE.**

### **GENERAL SAFETY, WARNINGS AND PRECAUTIONS**

#### **KEEP WORK AREA CLEAN AND DRY.**

Cluttered, damp or wet work areas invite injuries.

**STAY ALERT.** Watch what you are doing at all times. Use common sense. Do not use the greenhouse when you are tired or distracted from the job at hand. It is recommended to use gloves for assembling the greenhouse.

#### **MAINTAIN THIS PRODUCT WITH CARE.**

Keep the greenhouse clean and dry for better performance: maintenance should be performed regularly.

#### **USE THE RIGHT PRODUCT FOR THE JOB.**

Do not attempt to force a small product to do the work of a larger industrial product. There are certain applications for which the greenhouse was designed. It will do the job better and more safely in the manner for which it was intended. Do not modify the greenhouse and do not use the greenhouse for a purpose for which it was not intended.

#### **MAINTAIN A SAFE WORKING ENVIRONMENT.**

Keep the work area tidy. Make sure there is adequate surrounding workspace. Avoid high traffic areas. Always keep the work area free of obstructions, grease, oil, trash and other debris.

#### **PROPER GREENHOUSE LOCATION.**

Make sure the greenhouse is located on a flat level surface.

**POUR ÉVITER LES RISQUES DE BLESSURES, VEILLEZ LIRE ET COMPRENDRE LES INSTRUCTIONS DE MONTAGE DE LA SERRE AVANT DE L'UTILISER.**

### **SÉCURITÉ GÉNÉRALE, AVERTISSEMENTS ET PRÉCAUTIONS**

#### **GARDER LA ZONE DE TRAVAIL PROPRE ET SÈCHE.**

Les zones de travail encombrées, humides ou mouillées sont propices aux blessures.

**RESTEZ VIGILANT.** Surveillez ce que vous faites à tout moment. Faites preuve de bon sens. N'utilisez pas la serre lorsque vous êtes fatigué ou distrait du travail en cours. Il est recommandé d'utiliser des gants pour le montage de la serre.

#### **ENTRETIENEZ CE PRODUIT AVEC SOIN.**

Gardez la serre propre et sèche pour un meilleur rendement : l'entretien doit être effectué régulièrement.

#### **UTILISEZ LE PRODUIT APPROPRIÉ POUR LE TRAVAIL À EFFECTUER.**

N'essayez pas de forcer un petit produit à faire le travail d'un produit industriel plus important. La serre a été conçue pour certaines applications. Elle fera mieux le travail pour lequel elle a été conçue et de manière plus sûre. Ne modifiez pas la serre et n'utilisez pas la serre à des fins pour lesquelles elle n'a pas été conçue.

#### **MAINTENIR UN ENVIRONNEMENT DE TRAVAIL SÛR.**

Maintenez l'espace de travail en ordre. Assurez-vous que l'espace de travail environnant est adéquat. Évitez les zones à forte circulation. Maintenez la zone de travail toujours libre de tout obstacle, graisse, huile, déchets et autres débris.

#### **EMPLACEMENT ADÉQUAT DE LA SERRE.**

Veillez à ce que la serre soit située sur une surface plane et de niveau.

**ES**

**PARA PREVENIR LESIONES, LEA Y COMPRENDA LAS INSTRUCCIONES DE MONTAJE DEL INVERNADERO ANTES DE USARLO.**

### **SEGURIDAD GENERAL, ADVERTENCIAS Y PRECAUCIONES**

#### **MANTENGA EL ÁREA DE TRABAJO LIMPIA Y SECA.**

Las áreas de trabajo desordenadas, húmedas o mojadas pueden provocar lesiones. **MANTÉNGASE ALERTA.** Vigile lo que está haciendo en todo momento con el conocimiento común. No use el invernadero cuando esté cansado o distraído del trabajo en cuestión. Se recomienda utilizar guantes para montar el invernadero.

#### **MANTENGA ESTE PRODUCTO CON CUIDADO.**

Mantenga el invernadero limpio y seco para un mejor rendimiento: el mantenimiento debe realizarse con regularidad.

#### **USE EL PRODUCTO ADECUADO PARA EL TRABAJO.**

No intente forzar a un producto pequeño a hacer el trabajo que debe hacerse por un producto industrial más grande. Existen determinadas aplicaciones para las que se ha diseñado el invernadero. Puede hacer el trabajo mejor y con más seguridad si se usa en la manera para la que fue diseñado. No modifique el invernadero y no lo utilice para fines para los que no fue diseñado.

#### **MANTENGA UN AMBIENTE DE TRABAJO SEGURO.**

Mantenga el área de trabajo ordenada. Asegúrese de que haya un espacio de trabajo circundante adecuado. No lo use en las áreas de mucho tráfico. Mantenga siempre el área de trabajo libre de obstrucciones, grasa, aceite, basura y otros desechos.

#### **UBICACIÓN APROPIADA DEL INVERNADERO.**

Asegúrese de que el invernadero esté ubicado en una superficie plana y nivelada.

**PT**

### **SEGURANÇA GERAL, AVISOS E PRECAUÇÕES**

#### **MANTER A ÁREA DE TRABALHO LIMPA E SECA.**

As áreas de trabalho desorganizadas, húmidas ou molhadas provocam lesões. **ATENÇÃO:** Esteja sempre atento ao que está a fazer. Use comum sentido. Não utilizar a estufa quando estiver esgotado ou distraído do trabalho em questão. Recomenda-se o uso de luvas para montar a estufa.

#### **MANTENHA ESTE PRODUTO COM PRUDÊNCIA.**

Mantenha a estufa limpa e seca para um melhor desempenho: a manutenção deve ser feita regularmente.

#### **UTILIZAR O PRODUTO CERTO PARA O FUNCIONAMENTO.**

Não tentar forçar um produto pequeno a fazer o funcionamento de um produto industrial maior. Existem certas aplicações para as quais o estufa foi concebida. Fará o trabalho de forma melhor e mais segura da forma a que foi concebido. Não modificar a estufa e não utilizar a estufa para um fim para o qual não foi concebida.

#### **MANTER UM AMBIENTE DE TRABALHO SEGURO.**

Manter a área de trabalho arrumada. Certificar-se de que existe um ambiente de trabalho adequado espaço o suficiente. Manter sempre a área de trabalho livre de obstruções, gorduras, óleo, lixo e outros detritos.

#### **LOCALIZAÇÃO ADEQUADA DA ESTUFA.**

Certifique-se de que a estufa está localizada numa superfície de nivelada.

**Um Verletzungen zu vermeiden, lesen und verstehen Sie bitte vor dem Gebrauch die Anweisungen zur Montage des Gewächshauses.**

### **Allgemeine Sicherheit, Warnhinweise und Vorsichtsmaßnahmen**

#### **Halten Sie Arbeitsbereich sauber und trocken .**

Überfüllte, feuchte oder nasse Arbeitsbereiche können zu Verletzungen führen. **WACHSAM BLEIBEN.** Beobachten Sie jederzeit, was Sie tun. Verwenden Sie gesunden Menschenverstand. Verwenden Sie das Gewächshaus nicht, wenn Sie müde oder von der anstehenden Aufgabe abgelenkt sind. Es wird empfohlen, für die Montage des Gewächshauses Handschuhe zu tragen.

#### **Behalten Sie dieses Produkt mit Pflege**

Halten Sie das Gewächshaus sauber und trocken, um eine bessere Leistung zu erzielen: Regelmäßige Wartungsarbeiten sollten durchgeführt werden.

#### **Verwenden Sie das richtige Produkt für den Job**

Versuchen Sie nicht, ein kleines Produkt zu zwingen, die Arbeit eines größeren Industrieprodukts zu erledigen. Es gibt bestimmte Anwendungen, für die das Gewächshaus konzipiert wurde. Es wird die Arbeit besser und sicherer in der Weise erledigen, für die es bestimmt war. Ändern Sie das Gewächshaus nicht und verwenden Sie es nicht für Zwecke, für die es nicht vorgesehen war.

#### **Sorgen Sie für ein sicheres Arbeitsumfeld.**

Halten Sie den Arbeitsbereich sauber und ordentlich. Stellen Sie sicher, dass Sie genügend Arbeitsfläche um sich haben. Vermeiden Sie stark frequentierte Bereiche. Halten Sie den Arbeitsbereich immer frei von Hindernissen, Fett, Öl, Müll und anderen Fremdkörpern.

#### **Richtige Gewächshauslage.**

Stellen Sie sicher, dass sich das Gewächshaus auf einer ebenen Fläche befindet.

**PER PREVENIRE LESIONI, LEGGETE E COMPRENDETE LE ISTRUZIONI DI ASSEMBLAGGIO DELLA SERRA PRIMA DELL'USO.**

### **SICUREZZA GENERALE, AVVERTENZE E PRECAUZIONI**

#### **MANTENETE L'AREA DI LAVORO PULITA E ASCIUTTA.**

Le aree di lavoro disordinate, umide o bagnate potrebbero provocare lesioni. **STAI ATTENTO.** Stai attento su cosa stai facendo in ogni momento. Usa il senso comune e non usare la serra quando sei stanco o distratto nel lavoro da svolgere. Si consiglia di utilizzare i guanti per l'assemblaggio della serra.

#### **MANTENETE QUESTO PRODOTTO CON CURA.**

Mantieni la serra pulita e asciutta per prestazioni migliori: la manutenzione deve essere eseguita regolarmente.

#### **UTILIZZATE IL PRODOTTO GIUSTO PER IL LAVORO.**

Non tentare di forzare un prodotto piccolo a svolgere un lavoro di un prodotto industriale più grande. Ci sono alcune applicazioni per le quali il prodotto è stato progettato. Il prodotto funzionerà meglio e più sicuro nel modo per cui è stato progettato. Non modificare la serra e non utilizzare la serra per scopi per i quali non è stata concepita.

#### **MANTENETE UN AMBIENTE DI LAVORO SICURO.**

Tieni in ordine l'area di lavoro. Assicurati che ci sia uno spazio di lavoro circostante adeguato. Evita le zone di molto traffico. Mantieni sempre l'area di lavoro libera da ostruzioni, grasso, olio, rifiuti e altri detriti.

#### **POSIZIONE ADEGUATA DELLA SERRA.**

Assicurati che la serra si trovi su una superficie piana e livellata.

**PENTRU A PREVENI ACCIDENTAREA, CITIȚI ȘI ÎNȚELEGEȚI INSTRUCȚIUNILE DE ASAMBLARE A SEREI ÎNAINTE DE UTILIZARE.**

### **SIGURANȚĂ GENERALĂ, AVERTISMENTE ȘI PRECAUȚII**

#### **MENȚINEȚI ZONA DE LUCRU CURATĂ ȘI USCATĂ.**

Zonele de lucru aglomerate, umede sau ude pot provoca accidentări.

**FIȚI ATENȚI.** Fiți atenți la ceea ce faceți în permanență. Folosiți-vă bunul simț. Nu utilizați sera atunci când sunteți obosiți sau distrași de la sarcina pe care o aveți de îndeplinit. Se recomandă utilizarea mănușilor pentru asamblarea serii.

#### **ÎNGRIJIȚI CU ATENȚIE ACEST PRODUS.**

Păstrați sera curată și uscată pentru o performanță mai bună: întreținerea trebuie efectuată regulat.

#### **UTILIZAȚI PRODUSUL POTRIVIT PENTRU LUCRARE.**

Nu încercați să forțați un produs mic să facă treaba unui produs industrial mai mare.

Există anumite aplicații pentru care a fost proiectată sera. Aceasta va îndeplini sarcina mai bine și mai sigur în modul pentru care a fost concepută. Nu modificați sera și nu o utilizați într-un scop pentru care nu a fost concepută.

#### **MENȚINEȚI UN MEDIU DE LUCRU SIGUR.**

Păstrați zona de lucru ordonată. Asigurați-vă că există un spațiu de lucru adecvat în jur.

Evitați zonele cu trafic intens. Păstrați întotdeauna zona de lucru liberă de obstacole, grăsimi, ulei, gunoi și alte resturi.

#### **AMPLASAREA CORECTĂ A SEREI.**

Asigurați-vă că sera este amplasată pe o suprafață plană și orizontală.

**EN\_BOLT INSERTION**  
**FR\_INSERTION DES BOULONS**  
**ES\_INSERTIÓN DE PERNOS**  
**PT\_INSERTÃO DE PARAFUSOS**  
**DE\_SCHRAUBE EINSETZEN**  
**IT\_INSERTIMENTO DEI BULLONI**  
**RO\_INTRODUCEREA ȘURUBULUI**

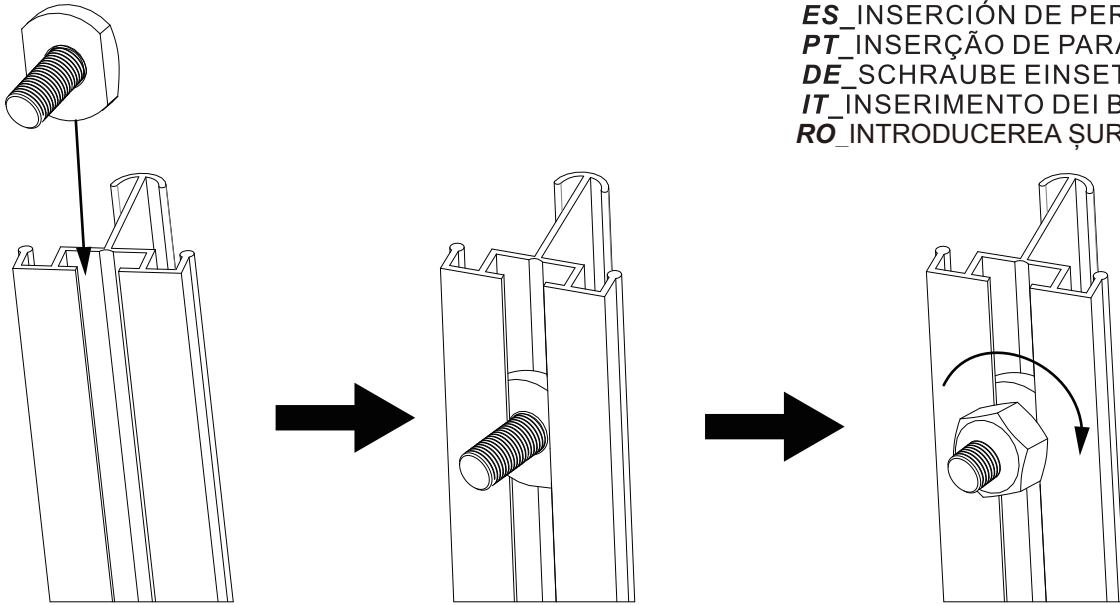

**EN** Several steps in this manual involve inserting F10 Bolts into the groove of Aluminum profiles as a preparation for further installation. Dia-grams above illustrate how to use such inserted bolts.

#### F10 BOLTS AND NUTS

Part No. F10 refers to both the bolt and the nut. In some steps only the bolt or the nut will be used and in other steps the whole set will be used. Check the specific Part List in each step.

**FR** Plusieurs étapes de ce manuel impliquent l'insertion de boulons F10 dans la rainure des profilés en aluminium afin de préparer l'installation ultérieure. Les diagrammes ci-dessus illustrent l'utilisation de ces boulons insérés.

#### BOULONS ET ÉCROUS F10

La référence F10 désigne à la fois le boulon et l'écrou. Dans certaines étapes, seul le boulon ou l'écrou sera utilisé, alors que dans d'autres étapes, l'ensemble sera utilisé. Consultez la liste des pièces spécifiques à chaque étape.

**ES** Varios pasos de este manual implican la inserción de pernos F10 en la ranura de los perfiles de aluminio como preparación para su posterior instalación. Los dia-gramas anteriores ilustran cómo utilizar dichos pernos insertados.

#### TORNILLOS Y TUERCAS F10

La referencia F10 se refiere tanto al tornillo como a la tuerca. En algunos pasos sólo se utilizará el tornillo o la tuerca y en otros pasos se utilizará todo el conjunto. Compruebe la lista de piezas específica de cada paso.

**PT** Vários passos deste manual envolvem a inserção de parafusos F10 na ranhura dos per s de alumínio como preparação para a instalação posterior. Os diagramas acima ilustram como utilizar esses parafusos inseridos.

#### PARAFUSOS E PORCAS F10

O número de peça F10 refere-se tanto ao parafuso como à porca. Em alguns passos, apenas o parafuso ou a porca serão utilizados e, noutros passos, será utilizado o conjunto completo. Verifique a lista de peças específica de cada passo.

**DE** Mehrere Schritte in diesem Handbuch beinhalten das Einsetzen von F10-Schrauben in die Nuten von Aluminiumprofilen als Vorbereitung für die weitere Montage. Die obigen Diagramme veranschaulichen die Verwendung solcher eingefügter Bolzen.

#### F10 SCHRAUBEN UND MUTTERN

Die Teile-Nr. F10 bezieht sich sowohl auf die Schraube als auch auf die Mutter. In einigen Schritten wird nur die Schraube oder die Mutter verwendet, in anderen Schritten wird der gesamte Satz verwendet. Überprüfen Sie die spezifische Teileliste in jedem Schritt.

**IT** Diverse fasi di questo manuale prevedono l'inserimento di bulloni F10 nella scanalatura dei profili di alluminio come preparazione per la successiva installazione. I diagrammi qui sopra illustrano come utilizzare i bulloni inseriti.

#### BULLONI E DADI F10

Il codice F10 si riferisce sia al bullone che al dado. In alcune fasi si utilizzerà solo il bullone o il dado, mentre in altre fasi si utilizzerà l'intero set. Controllare l'elenco dei componenti specifico di ogni fase.

**RO** Mai multe etape din acest manual implică introducerea șuruburilor F10 în canelura profilelor din aluminiu, ca pregătire pentru montarea ulterioară. Schemele de mai sus ilustrează modul de utilizare a acestor șuruburi introduse.

#### ȘURUBURI ȘI PIULIȚE F10

Numărul de piesă F10 se referă atât la șurub, cât și la piuliță. În unele etape se va folosi doar șurubul sau doar piulița, iar în alte etape se va folosi întregul set.

Verificați lista specifică de piese pentru fiecare etapă.

BOX 1/2					
Part No.	Part	Qty.	Part No.	Part	Qty.
01		2	36L		2
02		4	36R		2
03		4	36M		2
20-1		1	10		10
20-2		1	35L		1
24		1	35R		1
26		2	35M		1
27		1	11		10
33		2	15		2
30		4	14		1
32		2	19		1
16		1	B26		15
17		1	22		12
34L		2	B11		2
34R		2	B9		4
34M		2	B18		4
1		2	B15		2
29		2	B20		8
2		1	B21		2
3		1	B19		2
8		1	B2		18
9		1	39		1
23		4	50		1
31		1	49		1
4		1	S10		2
5		1	51		4
6		1	48		4
7		1	W4		2
12		1	S8		2
25		4	S9		2
			52		328

BOX 1/2		
Part No.	Part	Qty.
F3		32
F4		4
F5		80
F8		2
F9		2
F10		153
F13		16
F14		1

BOX 2/2		
Part No.	Part	Qty.
Q1		12
Q2		10
Q3		4
Q4		2
Q5		2
Q6		1
Q7		1
Q8		1
Q9		2
Q10		1
Q11		4

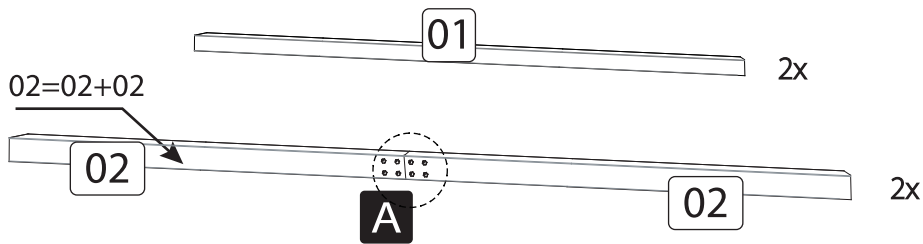
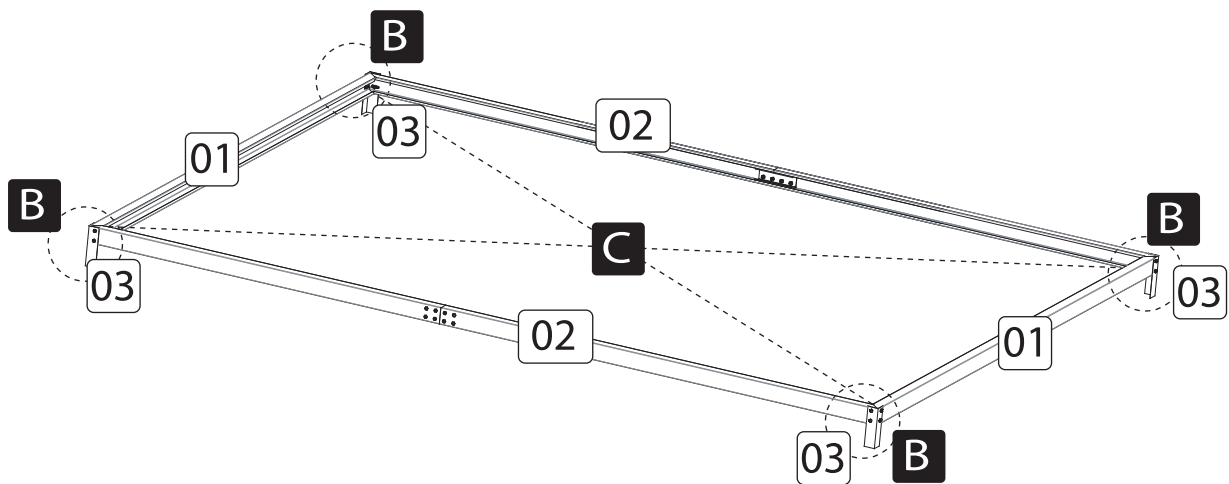

**OUTSIDE VIEW**

Teilenr.	Teil	Anz.
01		2
02		4
03		4
B11		2
F3		32

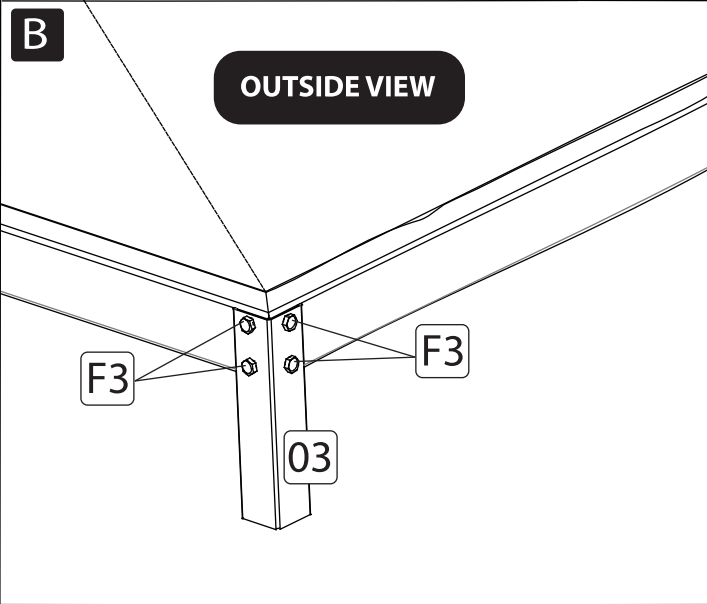
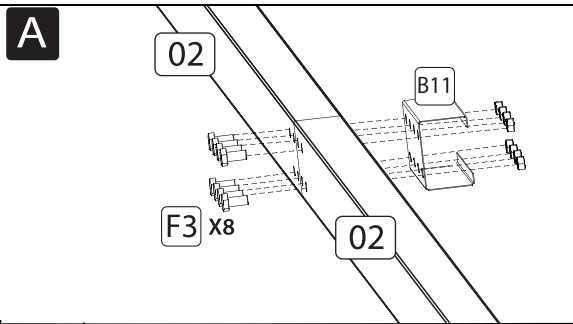



**EN\_** Take the fully assembled base to the chosen site and secure the base to the ground.

**TIP:** measure the length of the two diagonal of the base to make sure that the base is in a square shape.

Use a level to make sure the secured base is at.

**FR\_** Apportez la base entièrement assemblée sur le site choisi et fixez-la au sol.

**CONSEIL :** mesurez la longueur des deux diagonales de la base pour vous assurer qu'elle est bien carrée.

Utilisez un niveau pour vous assurer que la base fixée est à l'équerre.

**ES\_** Lleva la base completamente montada al lugar elegido y fijala al suelo.

**CONSEJO:** mide la longitud de las dos diagonales de la base para asegurarte de que la base tiene forma cuadrada.

Utilice un nivel para asegurarse de que la base fijada está a.

**PT\_** Leve a base completamente montada para o local escolhido e fixe-a ao solo.

**SUGESTÃO:** meça o comprimento das duas diagonais da base para se certificar de que a base tem uma forma quadrada.

Utilize um nível para se certificar de que a base fixada está no ponto.

**DE\_** Bringen Sie den fertig montierten Sockel an den gewählten Standort und befestigen Sie ihn auf dem Boden.

**TIPP:** Messen Sie die Länge der beiden Diagonalen des Sockels, um sicherzustellen, dass der Sockel eine quadratische Form hat.

Verwenden Sie eine Wasserwaage, um sicherzustellen, dass der befestigte Sockel waagrecht steht.

**IT\_** Portare la base completamente assemblata nel luogo prescelto e fissarla al terreno.

**CONSIGLIO:** misurate la lunghezza delle due diagonali della base per assicurarvi che la base sia di forma quadrata.

Utilizzare una livella per assicurarsi che la base fissata sia a livello.

**RO\_** Duceți baza complet asamblată la locul ales și fixați-o de sol.

**SFAT:** măsurați lungimea celor două diagonale ale bazei pentru a vă asigura că aceasta are formă pătrată.

Folosiți un nivel pentru a vă asigura că baza fixată este perfect orizontală.

**EN**\_Two foundation options with pre-fabricated Base  
**FR**\_Deux options de fondation avec base préfabriquée  
**ES**\_Dos opciones de cimentación con base prefabricada  
**PT**\_Duas opções de fundação com base pré-fabricada  
**DE**\_Zwei Fundamentoptionen mit vorgefertigtem Sockel  
**IT**\_Due opzioni di fondazione con base prefabbricata  
**RO**\_Două variante de fundație cu bază prefabricată

**EN**\_Option 1:Corner Stakes mounted into the soil  
**FR**\_Option 1:Piquets d'angle montés dans le sol  
**ES**\_Opción 1:Estacas de esquina instaladas en el suelo  
**PT**\_Opção 1:Estacas de canto montadas no solo  
**DE**\_Möglichkeit 1:In den Boden eingelassene Eckpfähle  
**IT**\_Opzione 1:Paletti angolari montati nel terreno  
**RO**\_Opțiunea 1: Țăruși de colț înfipti în pământ

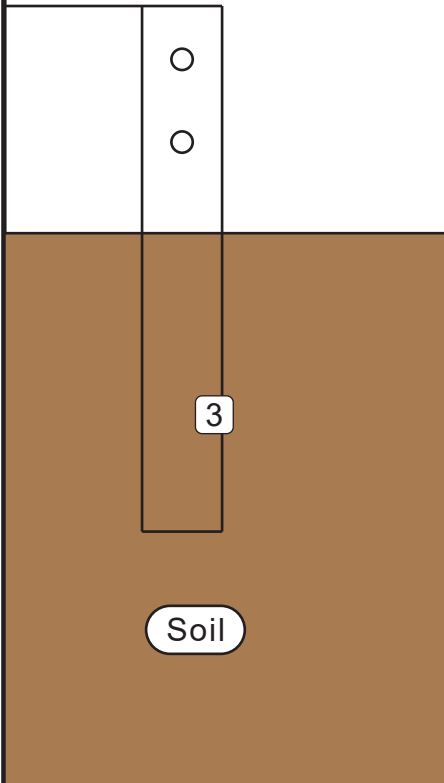

**EN**\_Option 2:Corner Stakes mounted into concrete  
**FR**\_Option 2:Piquets d'angle montés dans le béton  
**ES**\_Opción 2:Estacas de esquina montadas en hormigón  
**PT**\_Opção 2:Estacas de canto montadas em betão  
**DE**\_Möglichkeit 2:In Beton montierte Eckpfähle  
**IT**\_Opzione 2:Paletti d'angolo montati nel calcestruzzo  
**RO**\_Opțiunea 2: Țăruși de colț fixați în beton

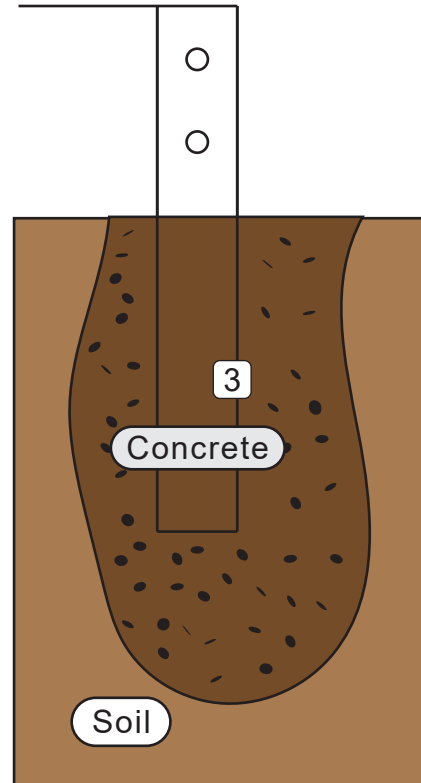

**EN**\_Easy and quick to install. Suitable to use in areas with less extreme weather

**FR**\_Facile et rapide à installer. Convient aux régions où les conditions météorologiques sont moins extrêmes.

**ES**\_Fácil y rápido de instalar. Adecuado para su uso en zonas con climas menos extremos

**PT**\_Fácil e rápido de instalar. Adequado para utilização em zonas com condições climáticas menos extremas

**DE**\_Einfach und schnell zu installieren. Geeignet für den Einsatz in Gebieten mit weniger extremen Wetterbedingungen

**IT**\_Facile e veloce da installare. Adatto all'uso in aree con clima meno estremo

**RO**\_Ușor și rapid de instalat. Potrivit pentru utilizarea în zone cu condiții meteorologice mai puțin extreme

**EN**\_Best option if you want your greenhouse fully secured.

**FR**\_La meilleure option si vous souhaitez que votre serre soit entièrement sécurisée.

**ES**\_La mejor opción si desea que su invernadero esté totalmente protegido.

**PT**\_A melhor opção se quiser que a sua estufa fique totalmente protegida.

**DE**\_Die beste Option, wenn Sie Ihr Gewächshaus vollständig sichern wollen.

**IT**\_L'opzione migliore se volete che la vostra serra sia completamente protetta.

**RO**\_Cea mai bună opțiune dacă doriți ca sera dumneavoastră să fie complet securizată.

### **EN\_Option 3**

For installation on hard surfaces (such as concrete floors), the corner posts should be stood up and fixed to the ground using expansion bolts.

If it's a wooden floor, self-tapping screws can be used for fastening (the fixing screws are not included and need to be purchased separately). Before fixing, prepare the appropriate drill bits for the screw size and drill holes at the corner post locations to facilitate the installation.

### **FR\_Option 3**

Pour une installation sur des surfaces dures (telles que des sols en béton), les poteaux d'angle doivent être dressés et fixés au sol à l'aide de boulons d'expansion.

S'il s'agit d'un sol en bois, des vis autotaraudeuses peuvent être utilisées pour la fixation (les vis de fixation ne sont pas incluses et doivent être achetées séparément). Avant de procéder à la fixation, préparez les mèches appropriées à la taille des vis et percez des trous aux emplacements des poteaux d'angle pour faciliter l'installation.

### **ES\_Opción 3**

Para la instalación en superficies duras (como suelos de hormigón), los postes esquineros deben levantarse y fijarse al suelo mediante pernos de expansión.

Si se trata de un suelo de madera, pueden utilizarse tornillos autorroscantes para la fijación (los tornillos de fijación no se incluyen y deben adquirirse por separado). Antes de la fijación, prepare las brocas adecuadas para el tamaño del tornillo y taladre agujeros en las ubicaciones de los postes esquineros para facilitar la instalación.

### **PT\_Opção 3**

Para instalação em superfícies duras (como pisos de betão), os postes de canto devem ser levantados e fixados ao chão com parafusos de expansão.

Se for um piso de madeira, podem ser utilizados parafusos auto-roscantes para a fixação (os parafusos de fixação não estão incluídos e têm de ser adquiridos separadamente). Antes de fixar, prepare as brocas adequadas para o tamanho do parafuso e faça furos nos locais dos postes de canto para facilitar a instalação.

### **DE\_Option 3**

Bei der Installation auf harten Oberflächen (z. B. Betonböden) sollten die Eckpfosten aufgerichtet und mit Spreizdübeln am Boden befestigt werden.

Handelt es sich um einen Holzboden, können selbstschneidende Schrauben zur Befestigung verwendet werden (die Befestigungsschrauben sind nicht im Lieferumfang enthalten und müssen separat erworben werden). Bereiten Sie vor der Befestigung die passenden Bohrer für die Schraubengröße vor und bohren Sie Löcher an den Stellen der Eckpfosten, um die Montage zu erleichtern.

### **IT\_Opzione 3**

Per l'installazione su superfici dure (come pavimenti in cemento), i montanti angolari devono essere alzati e fissati al suolo con tasselli a espansione.

Se si tratta di un pavimento in legno, è possibile utilizzare viti autofilettanti per il fissaggio (le viti di fissaggio non sono incluse e devono essere acquistate separatamente). Prima del fissaggio, preparare le punte adatte alle dimensioni delle viti e praticare i fori in corrispondenza dei montanti angolari per facilitare l'installazione.

### **RO\_Opțiunea 3**

Pentru montarea pe suprafețe dure (cum ar fi pardoselile din beton), stâlpii de colț trebuie așezați în poziție verticală și fixați de sol cu ajutorul unor șuruburi de expansiune.

În cazul unei pardoseli din lemn, pentru fixare se pot folosi șuruburi autofiletante (șuruburile de fixare nu sunt incluse și trebuie achiziționate separat). Înainte de fixare, pregătiți burghiele adecvate pentru dimensiunea șuruburilor și realizați găuri în locurile unde vor fi amplasați stâlpii de colț, pentru a facilita instalarea.

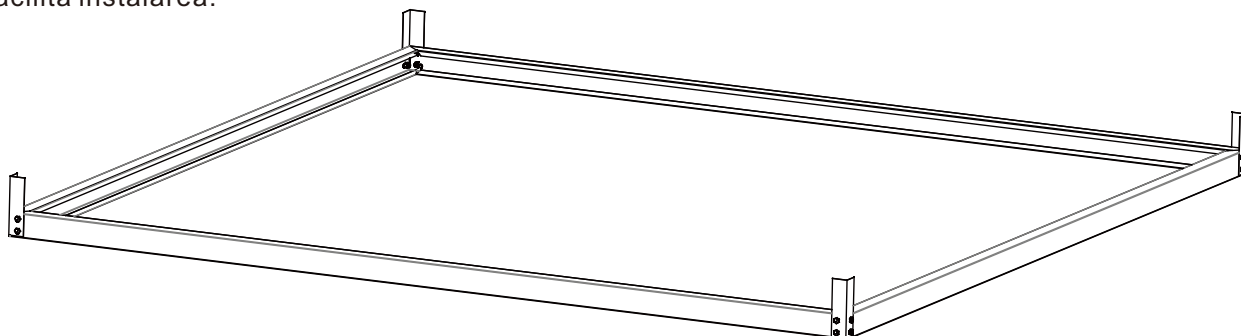

# Door

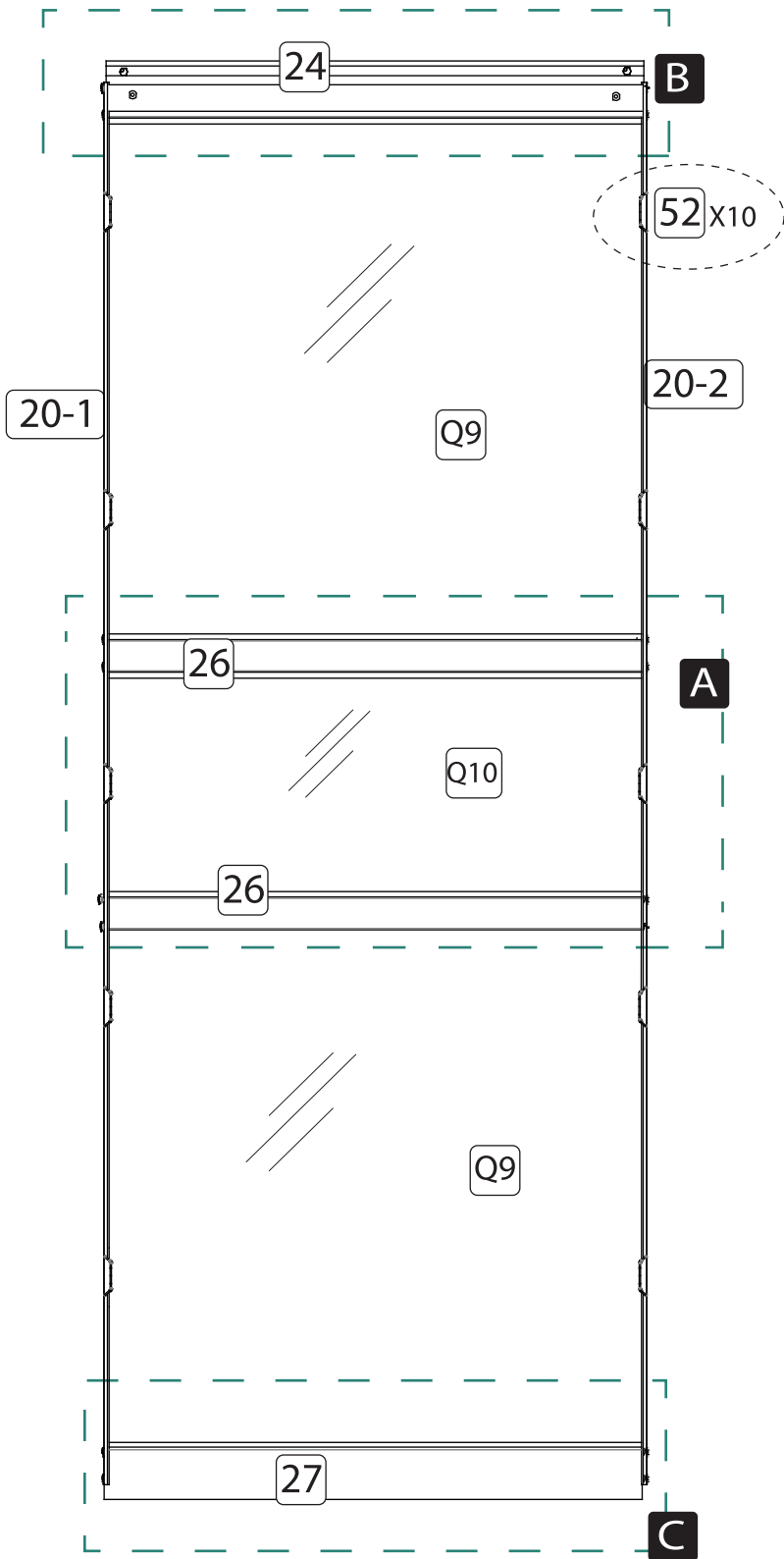

52x10

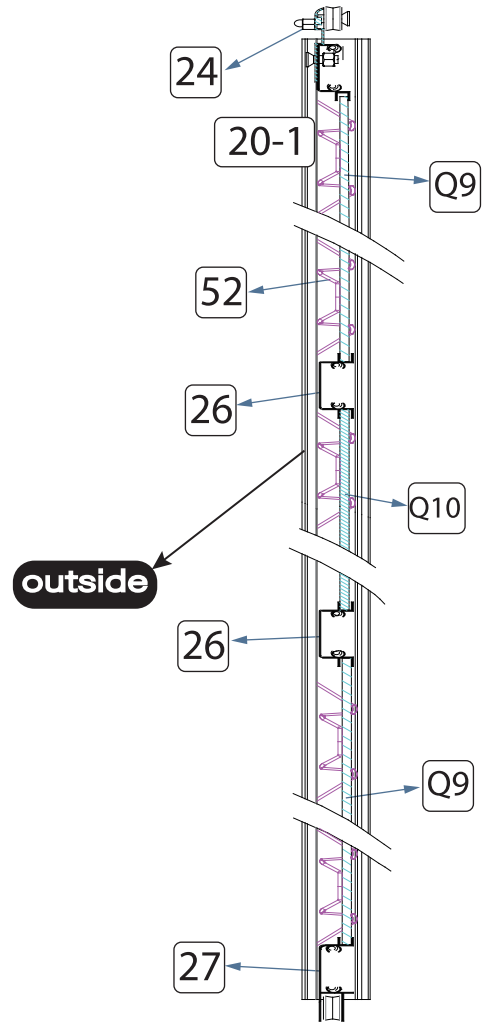

outside

Part No.	Part	Qty.
20-1		1
20-2		1
24		1
26		2
27		1
Q9		2
Q10		1
F13		16
52		10

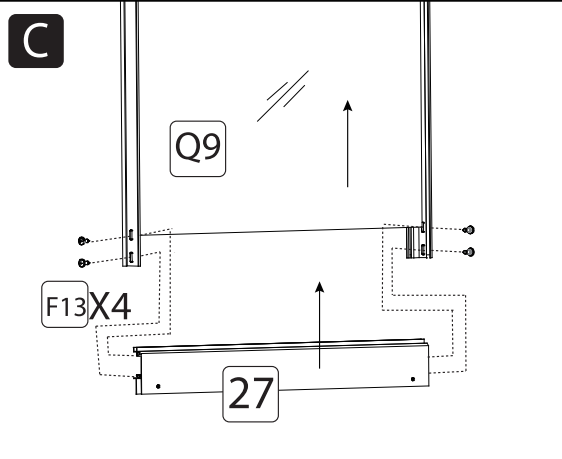
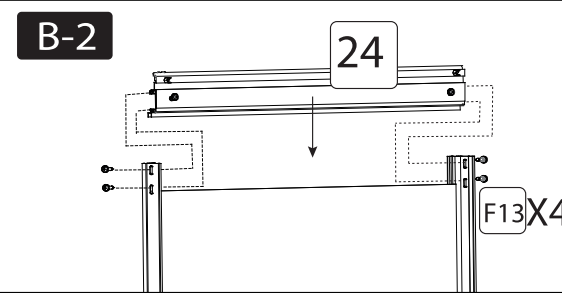
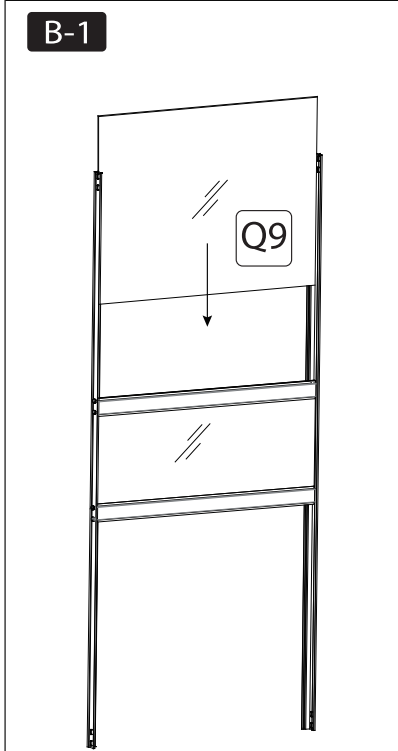
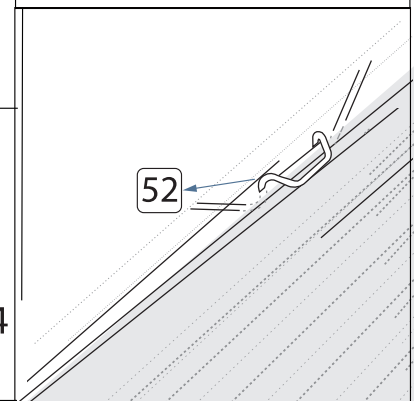
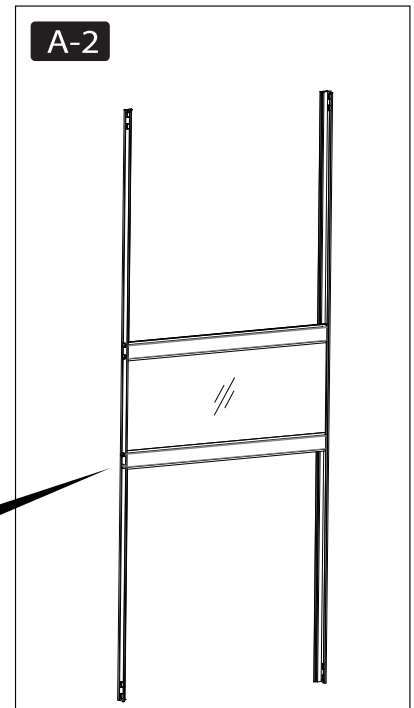
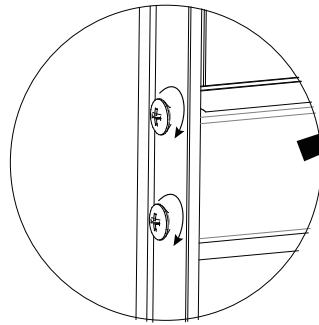
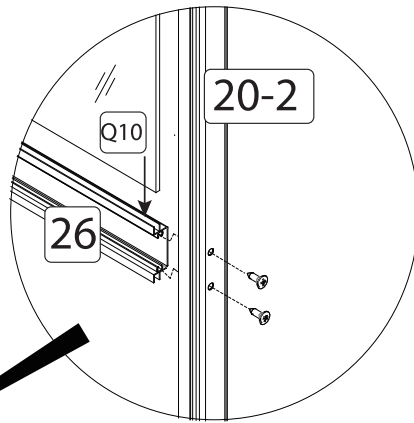
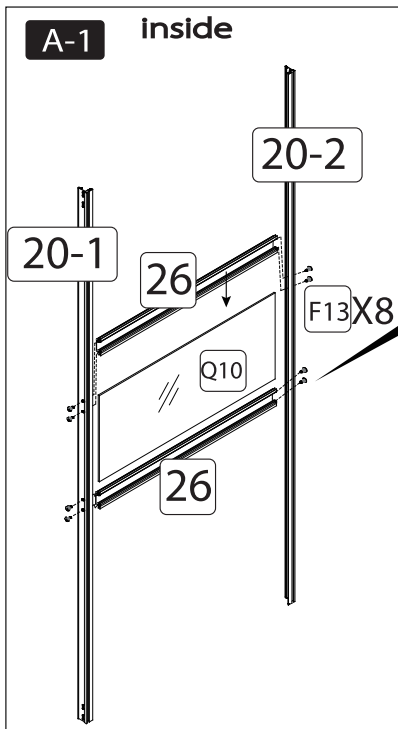

**EN\_1.** Place the two ends of the clip into the groove of the frame.  
2. Position the middle section of the clip against the hollow chamber panel.

Two edges of the clip are under the edge of the hollow chamber panel, and the middle edge holds the panel in place.

**FR\_1.** Placer les deux extrémités du clip dans la rainure du cadre.  
2. Placer la partie centrale du clip contre le panneau de la chambre creuse.

Les deux bords du clip se trouvent sous le bord du panneau de la chambre creuse, et le bord central maintient le panneau en place.

**ES\_1.** Coloque los dos extremos del clip en la ranura del marco.

2. Coloque la sección central del clip contra el panel de la cámara hueca.

Dos bordes del clip quedan por debajo del borde del panel de la cámara hueca, y el borde central sujeta el panel en su sitio.

**PT\_1.** Coloque as duas extremidades do clip na ranhura da estrutura.

2. Coloque a secção central do clipe contra o painel da câmara oca.

Dois extremidades do clip estão sob a extremidade do painel da câmara oca e a extremidade central mantém o painel no lugar.

**DE\_1.** Stecken Sie die beiden Enden des Clips in die Nut des Rahmens.

2. Legen Sie den mittleren Teil des Clips gegen die Hohlkammerplatte.

Zwei Kanten des Clips liegen unter der Kante der Hohlkammerplatte, die mittlere Kante hält die Platte fest.

**IT\_1.** Inserire le due estremità della clip nella scanalatura del telaio.

2. Posizionare la sezione centrale della clip contro il pannello della camera cava.

Due bordi della clip si trovano sotto il bordo del pannello della camera cava, mentre il bordo centrale tiene il pannello in posizione.

**RO\_1.** Introduceți cele două capete ale clemei în canelura cadrului.

2. Așezați partea centrală a clemei pe panoul cu cameră goală.

Cele două margini ale clemei se află sub marginea panoului cu cameră goală, iar marginea din mijloc menține panoul în poziție

# window

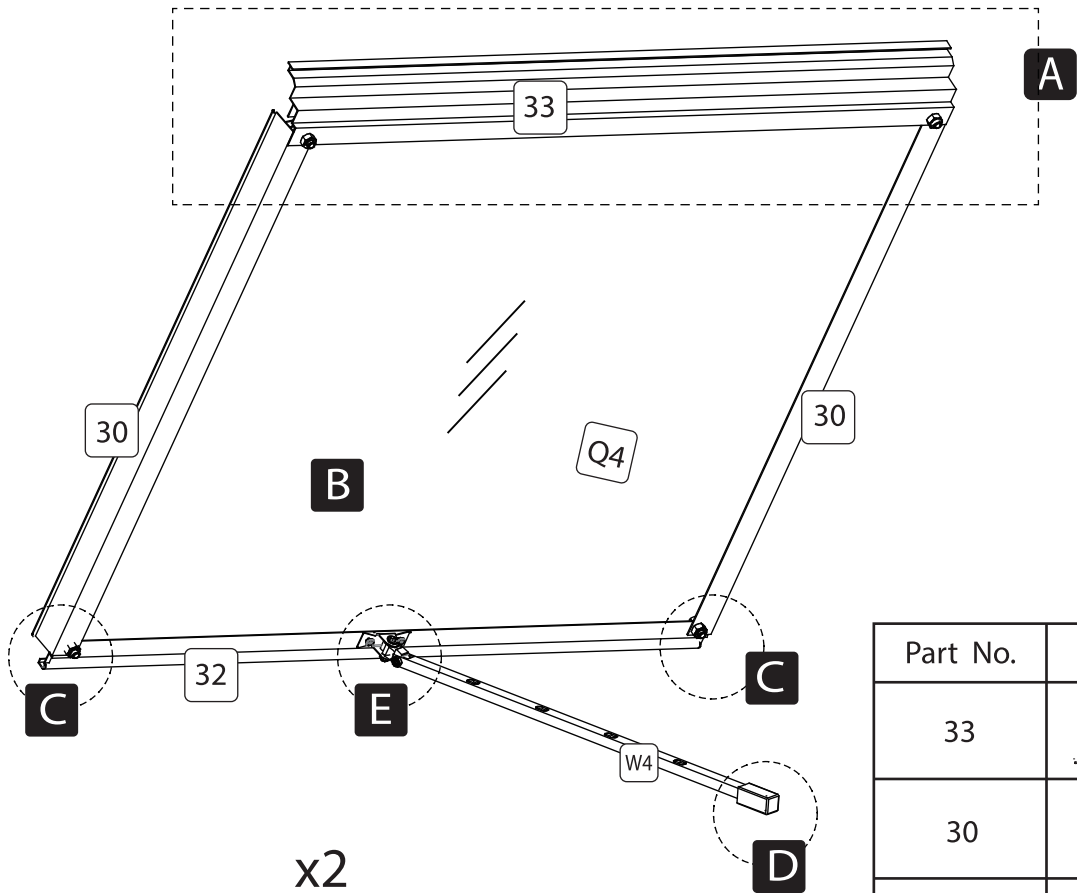

x2

Part No.	Part	Qty.
33		2
30		4
32		2
W4		2
S8		2
S9		2
F10		8
F8		2
F9		2
Q4		2

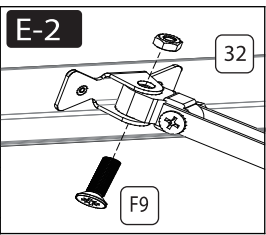
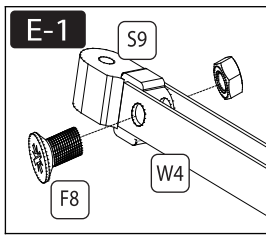
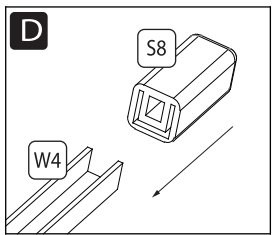

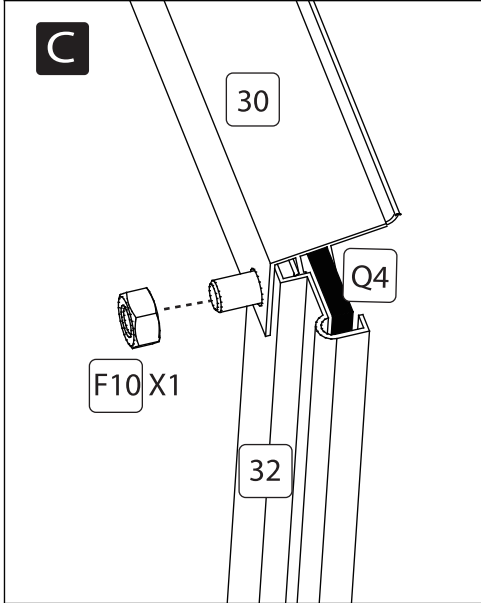
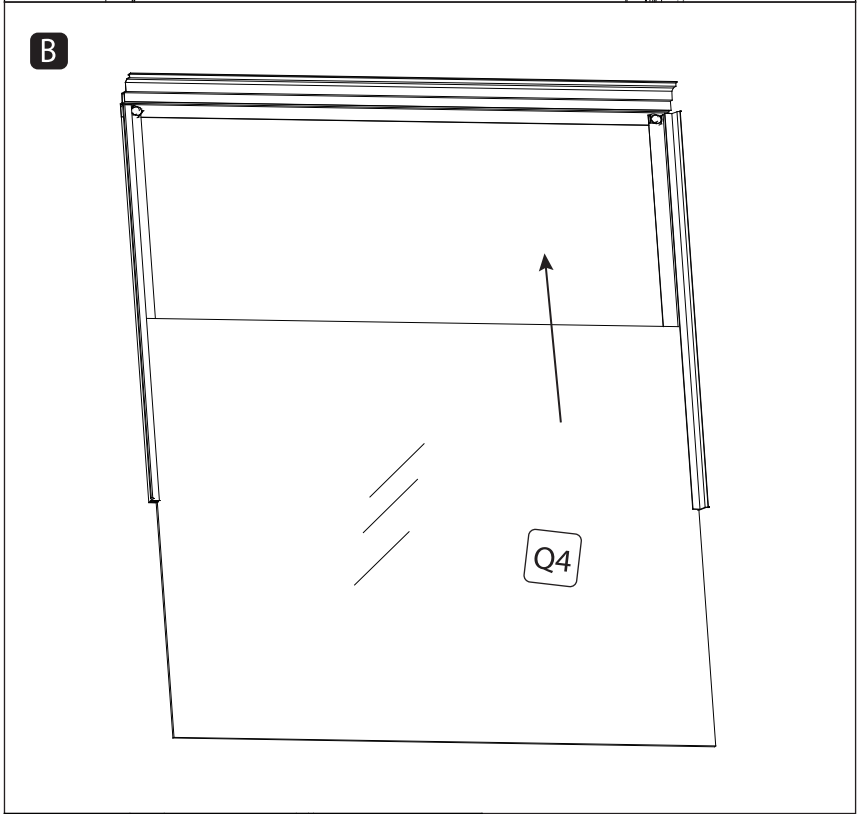
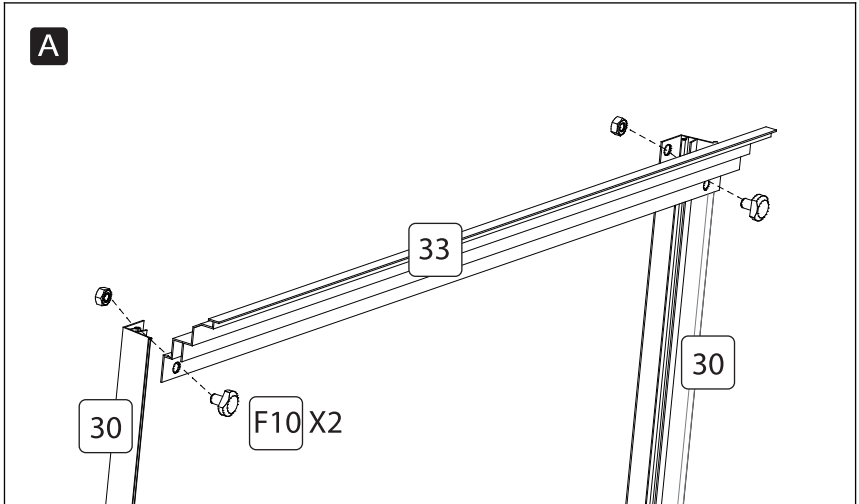

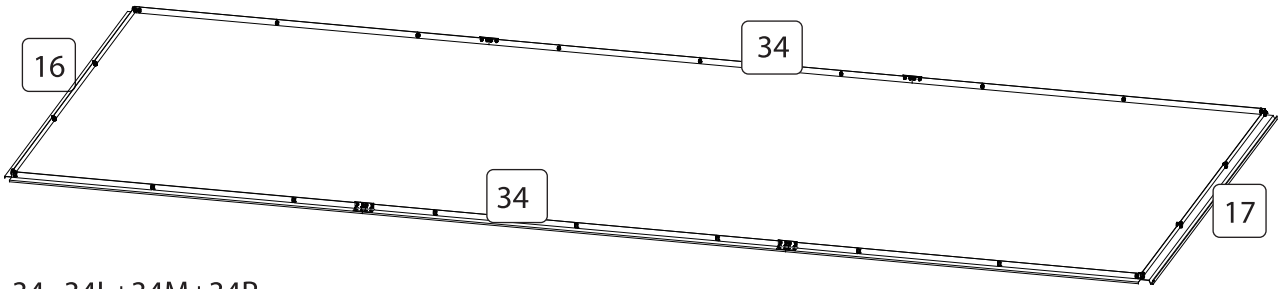

$34 = 34L + 34M + 34R$

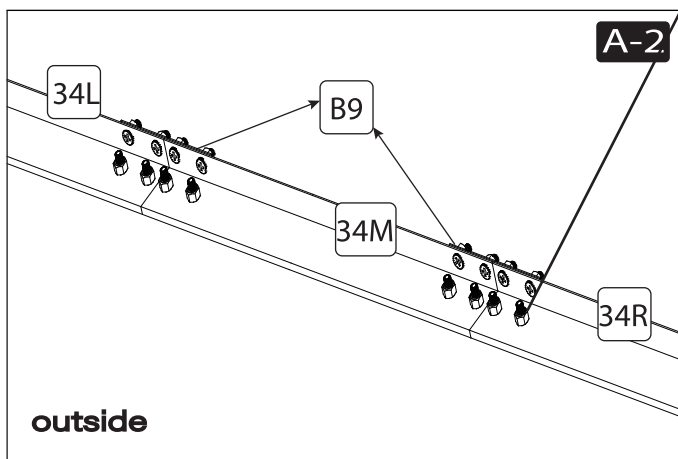
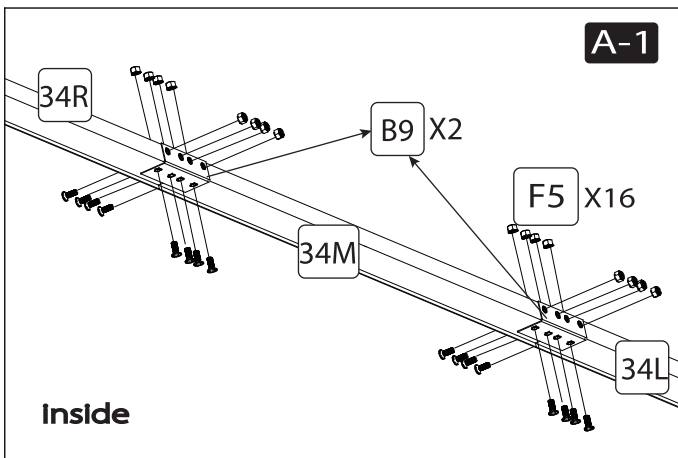
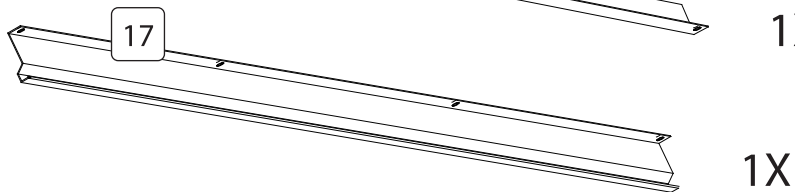
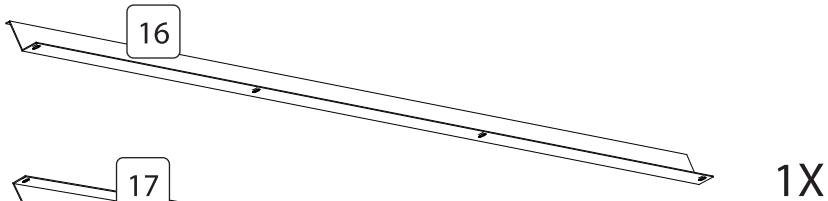
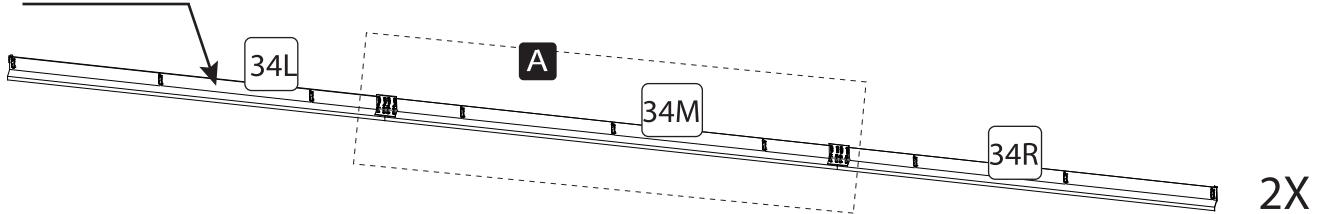

**EN** Pay attention to the nut installation direction  
**FR** Attention au sens d'installation de l'écrou  
**ES** Preste atención a la dirección de instalación de la tuerca  
**PT** Prestar atenção à direção de instalação da porca  
**DE** Achten Sie auf die Montagerichtung der Mutter  
**IT** Prestare attenzione alla direzione di installazione del dado  
**RO** Acordați atenție sensului de montare a piuliței a piuliței

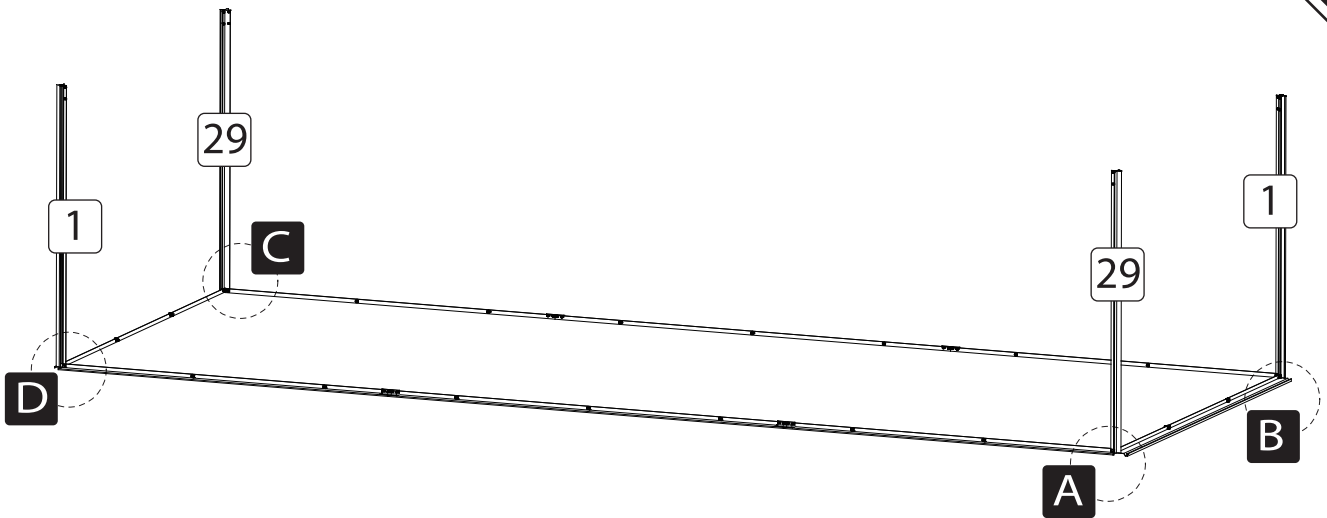

Part No.	Part	Qty.
16		1
17		1
34L		2
34R		2
34M		2
B9		4
F5		32



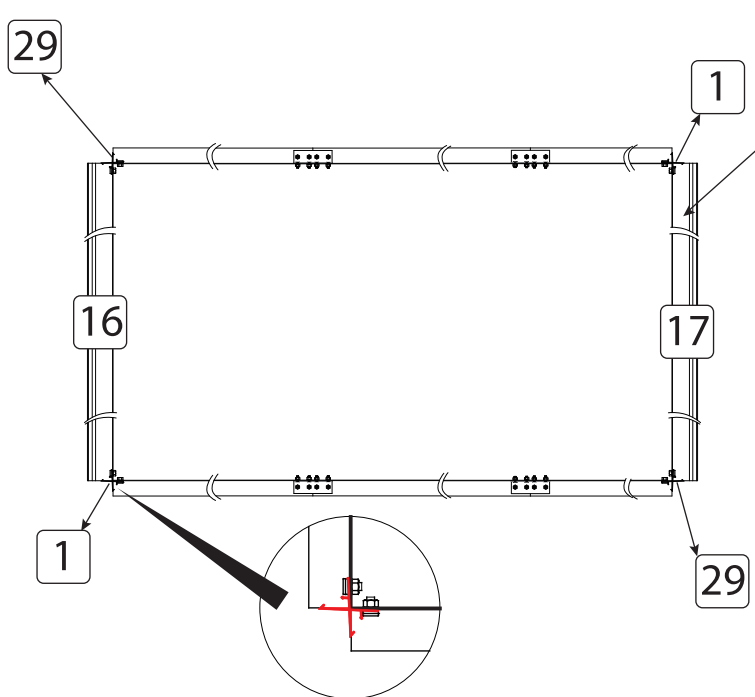
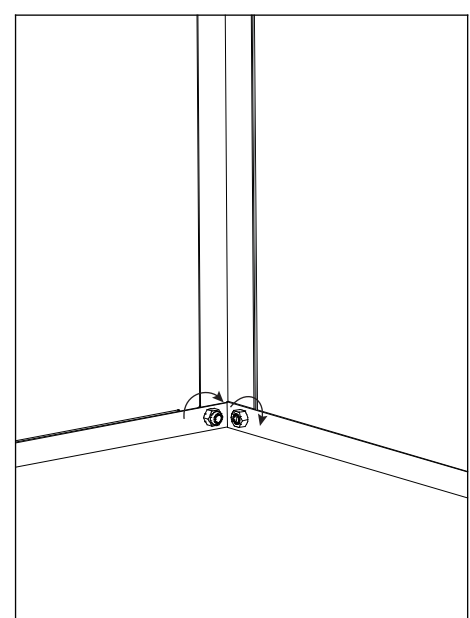
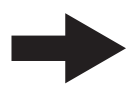
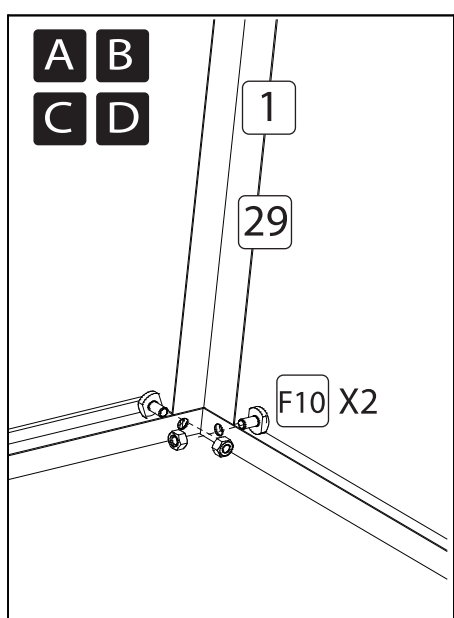



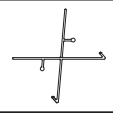



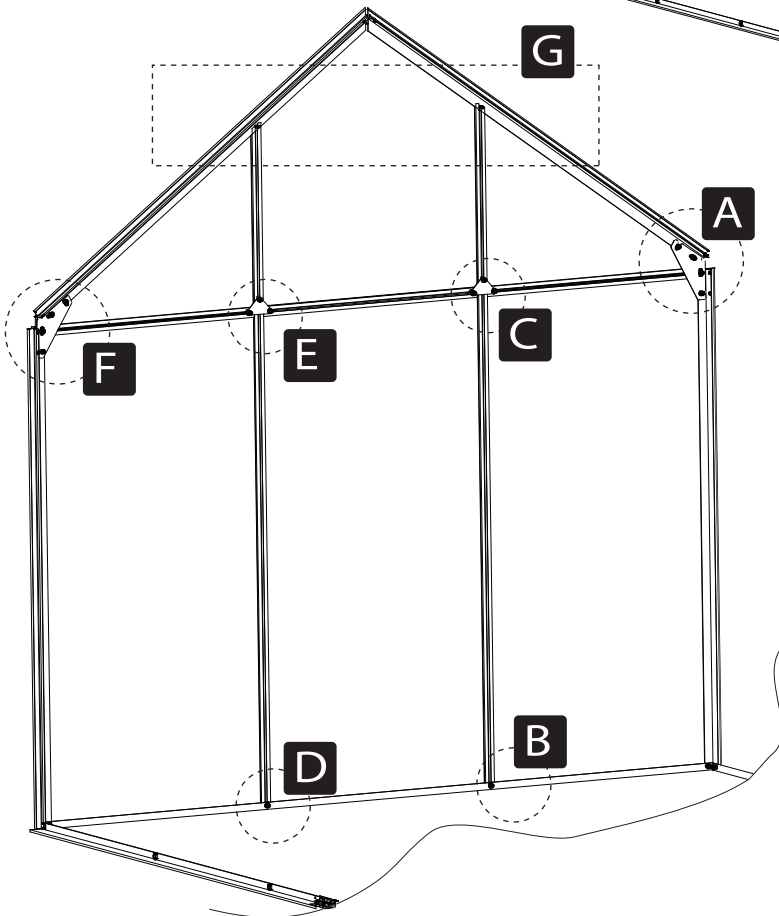
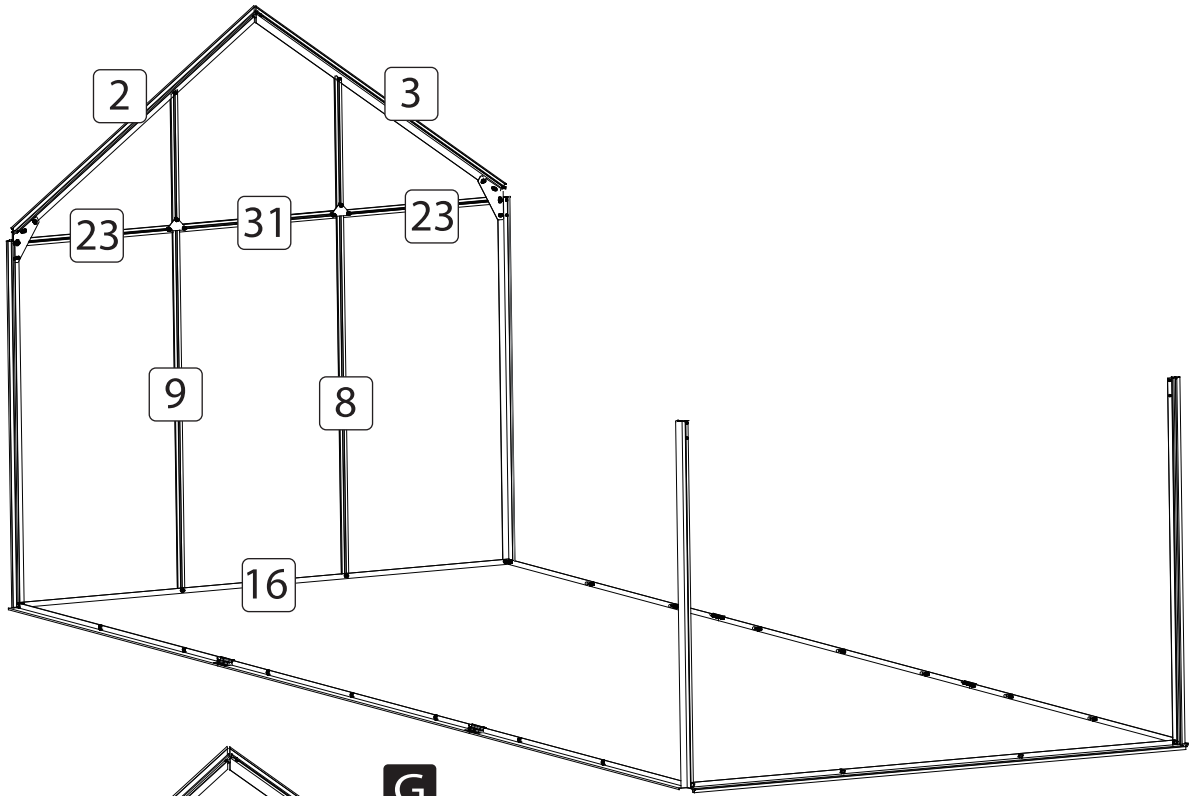

**inside**



**EN\_** The position of installing door  
**FR\_** La position d'installation de la porte  
**ES\_** La posición de instalación de la puerta  
**PT\_** A posição de instalação da porta  
**DE\_** Die Position des Einbaus der Tür  
**IT\_** La posizione di installazione della porta  
**RO\_** Poziția de montare a ușii

Part No.	Part	Qty.
1		2
29		2
F10		8



Part No.	Part	Qty.
2		1
3		1
8		1
9		1
23		2
31		1
B18		2
B15		2
F10		18

**A**

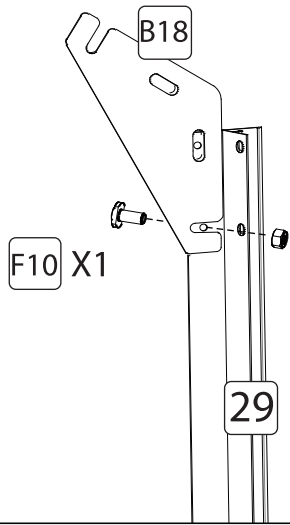

**B**

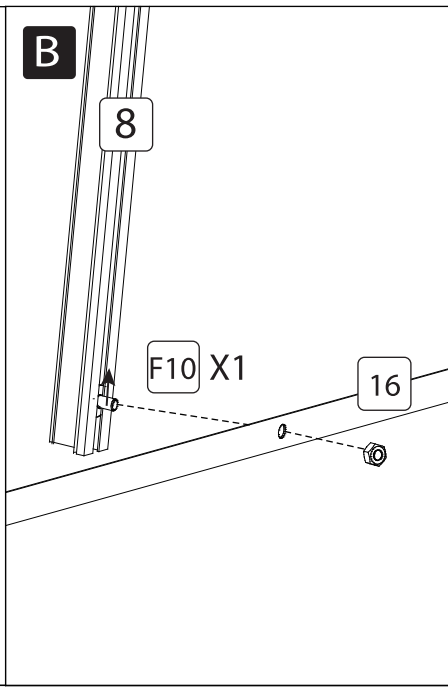

**C-1**

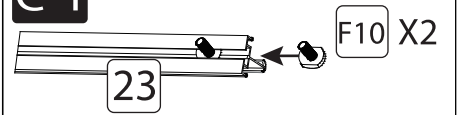

**C-2**

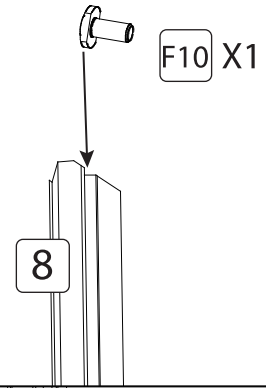

**C-3**

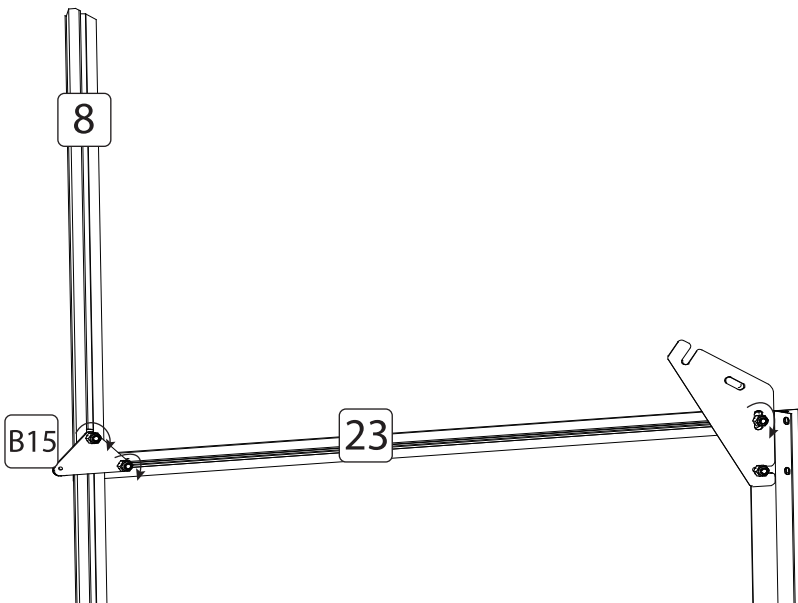

**D**

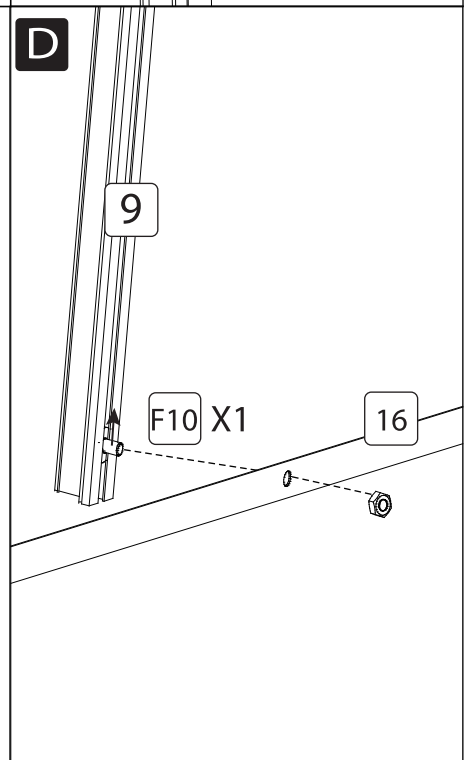

**E-1**

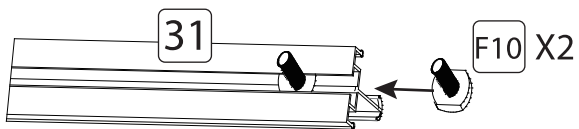

**E-2**

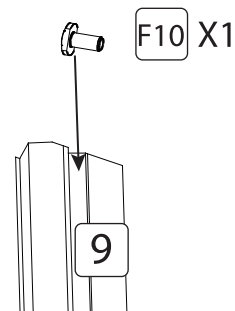

inside

E-3

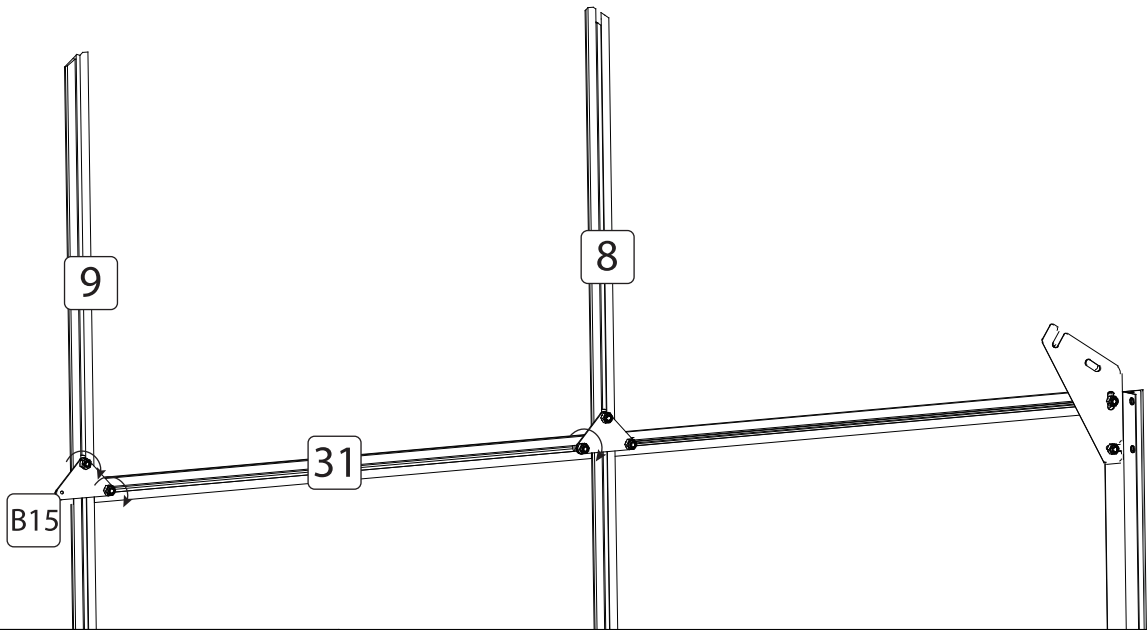

F-1

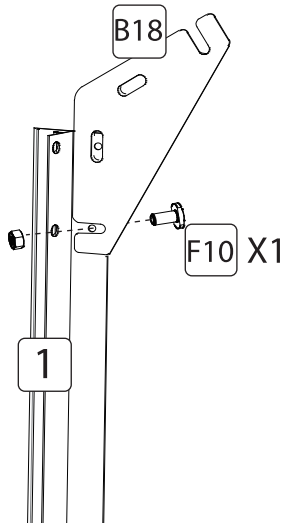

F-2

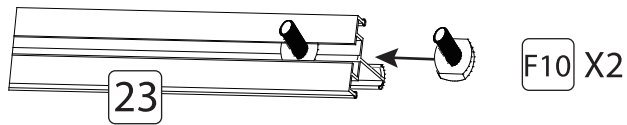

F-3

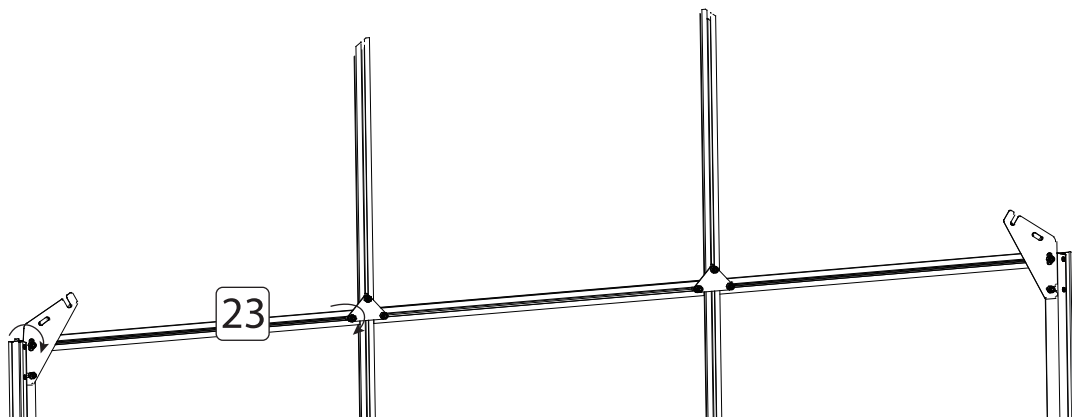

inside

G-1

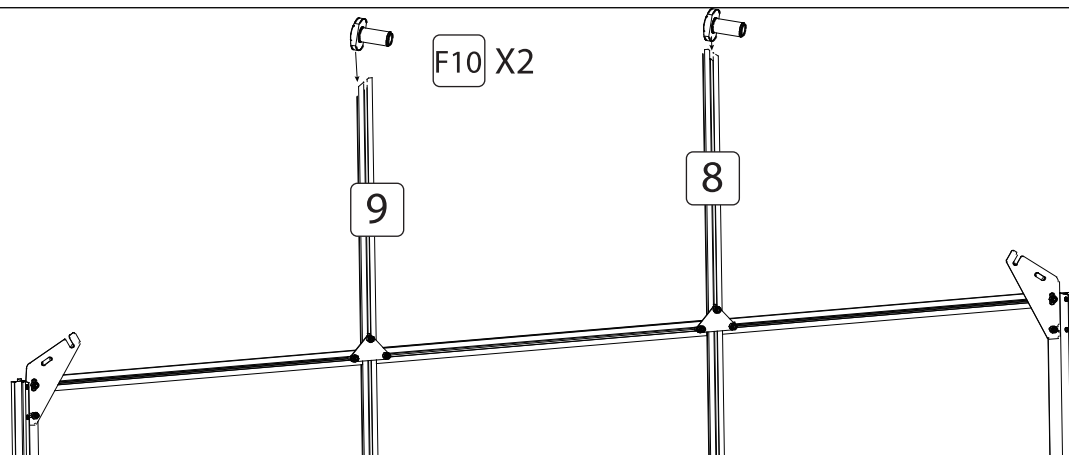

G-2

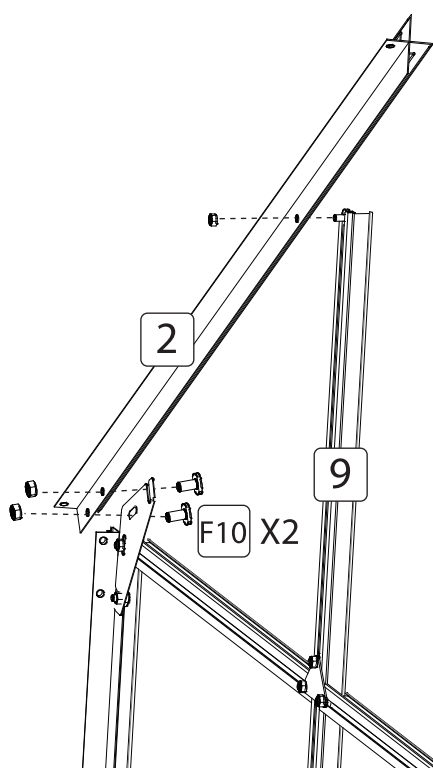

G-3

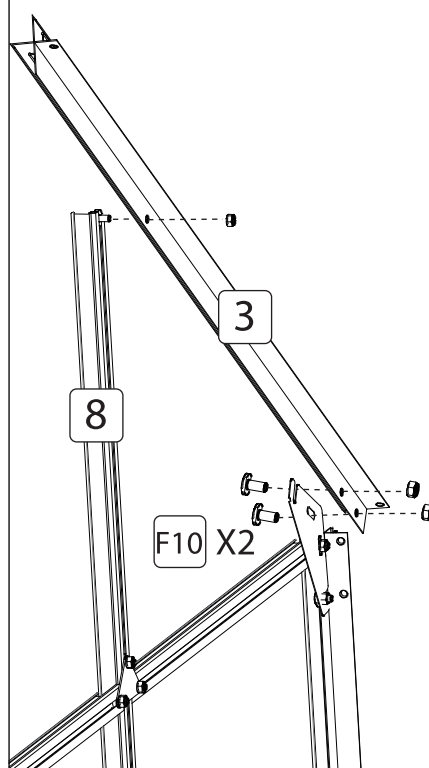

G-4

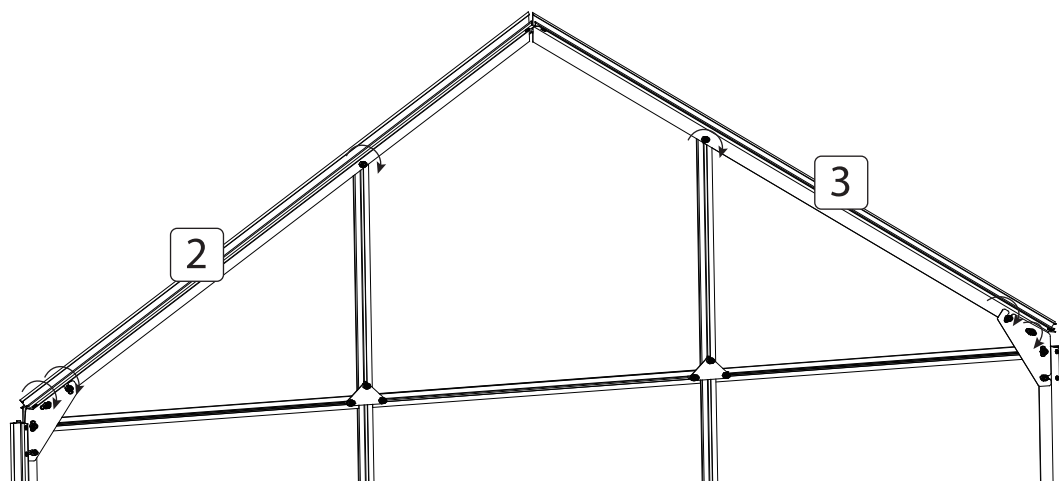

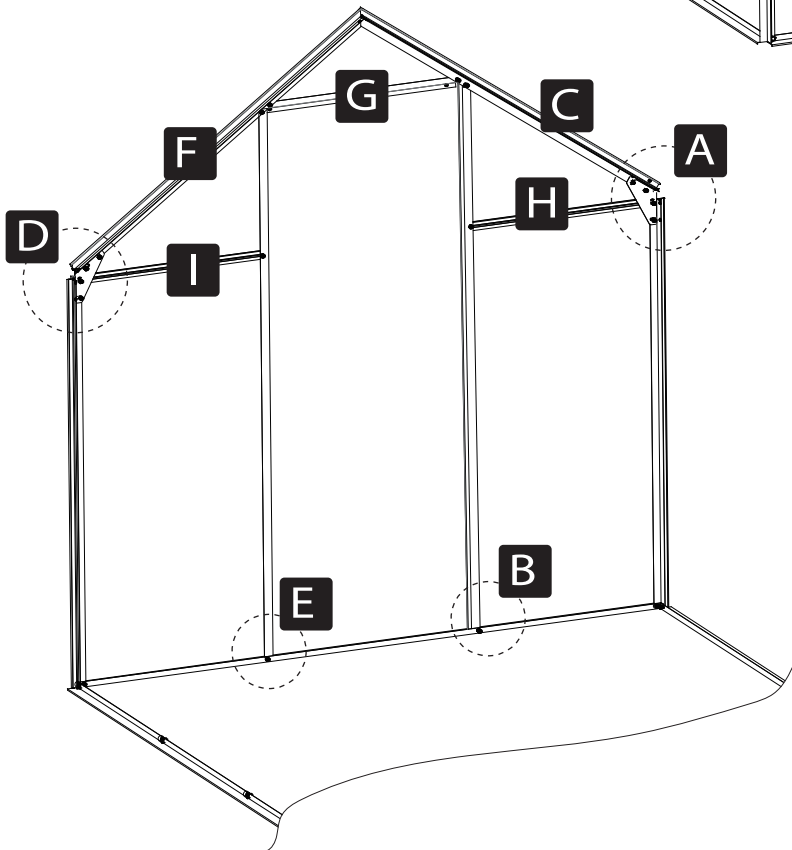
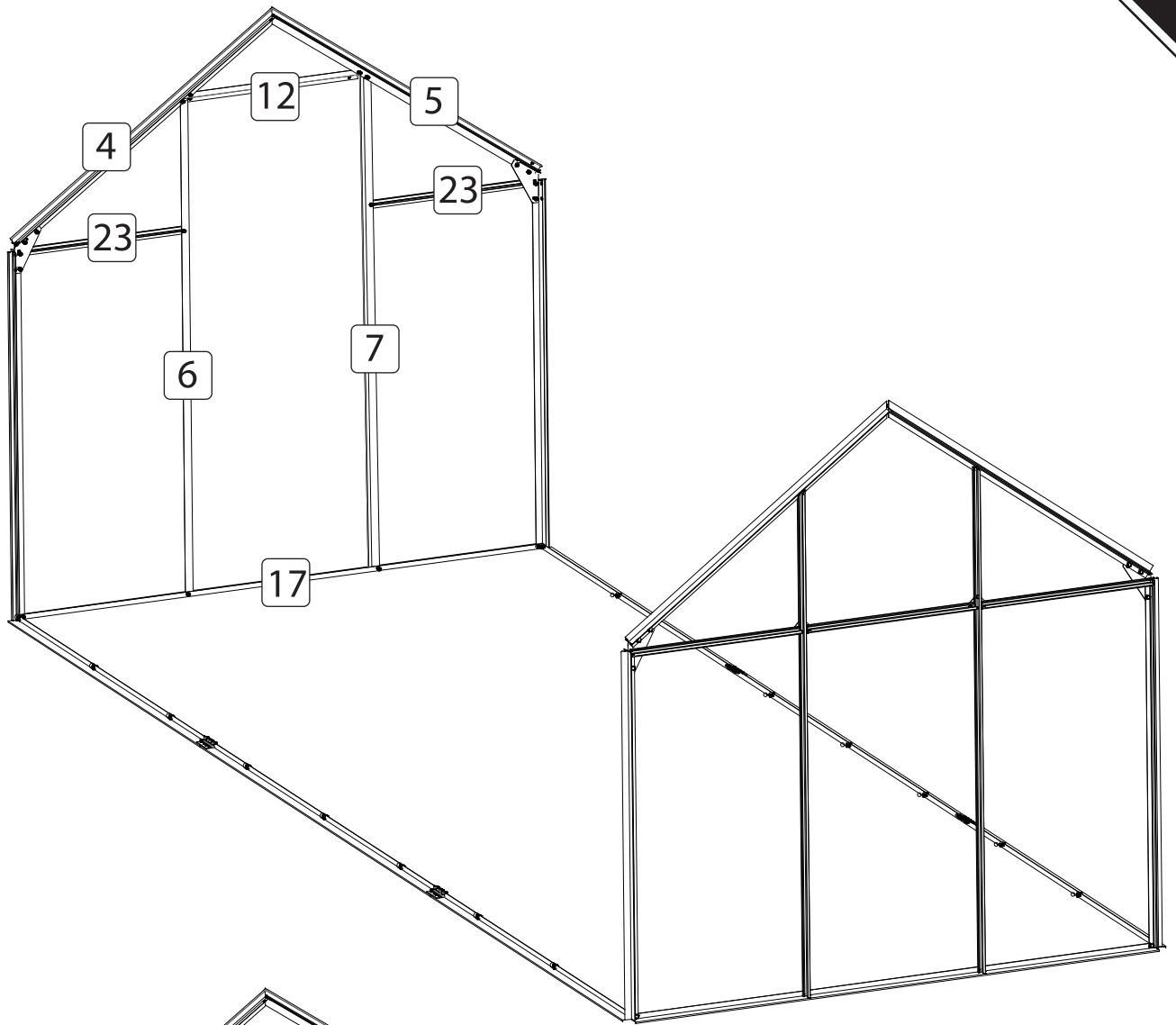

Part No.	Part	Qty.
4		1
5		1
6		1
7		1
12		1
23		2
B18		2
F10		16

**inside**

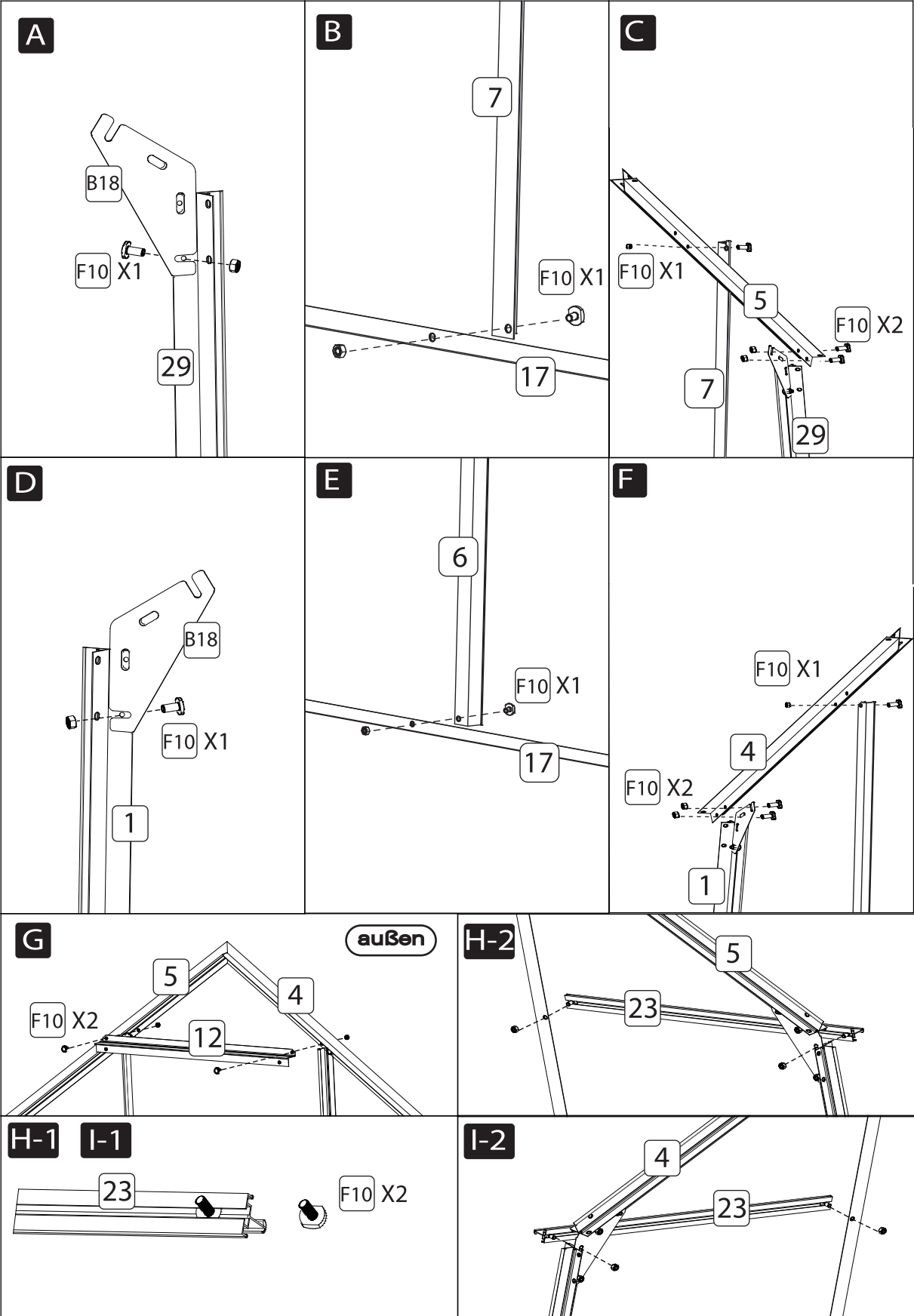

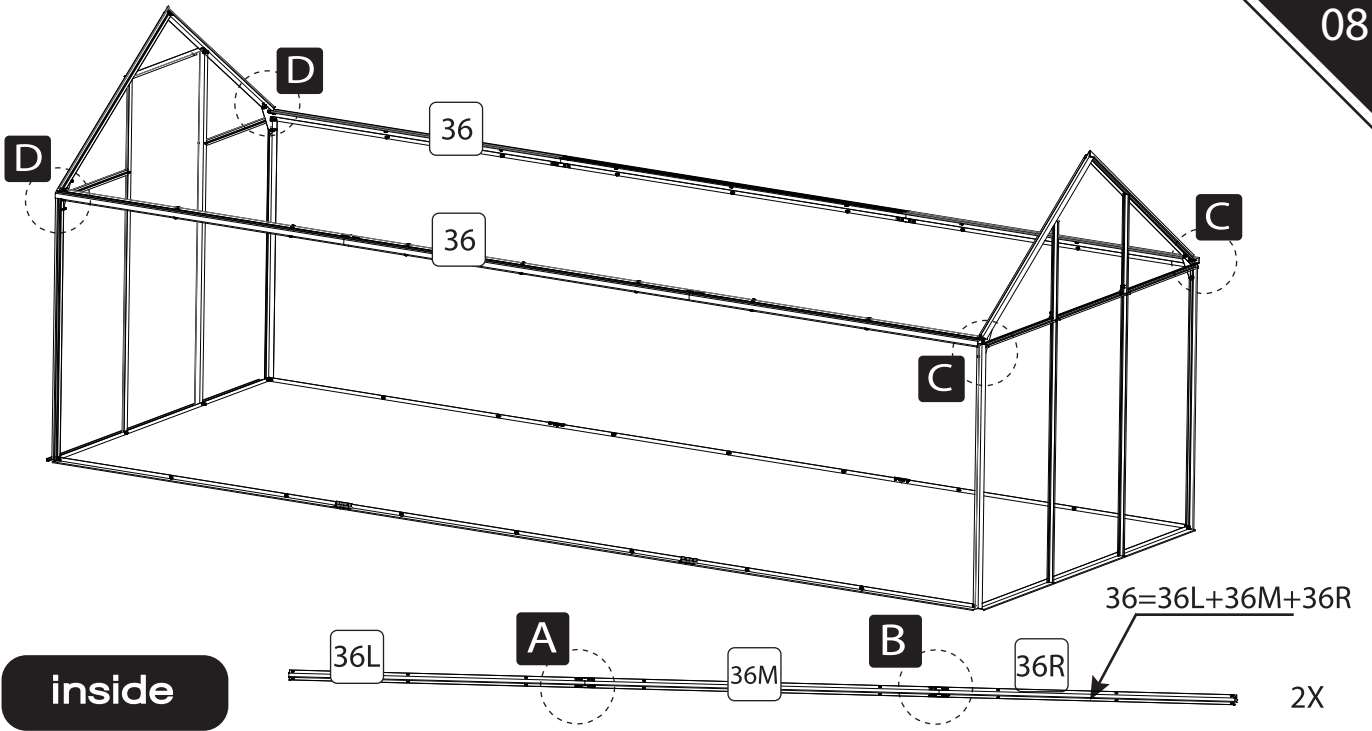



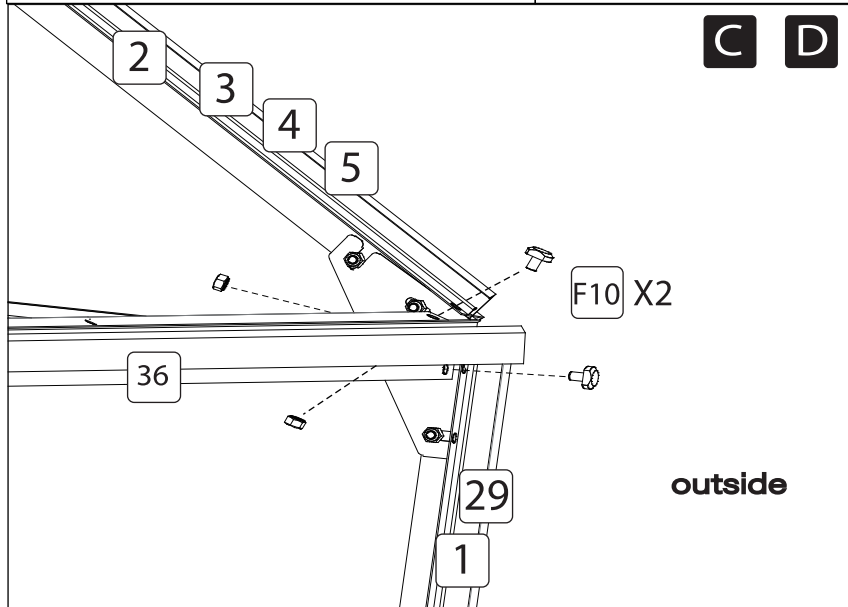
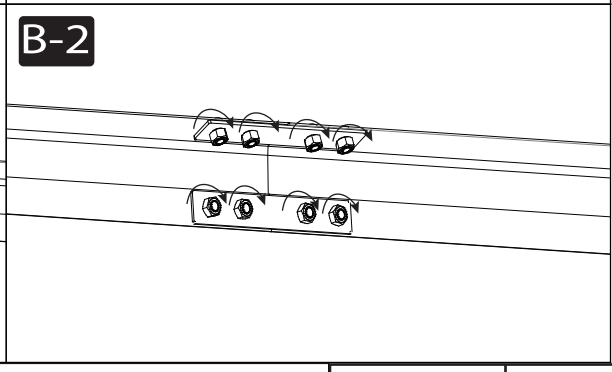
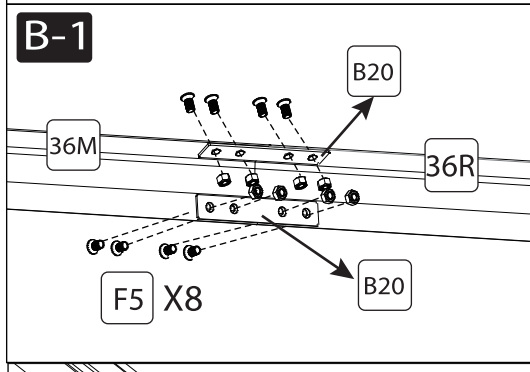
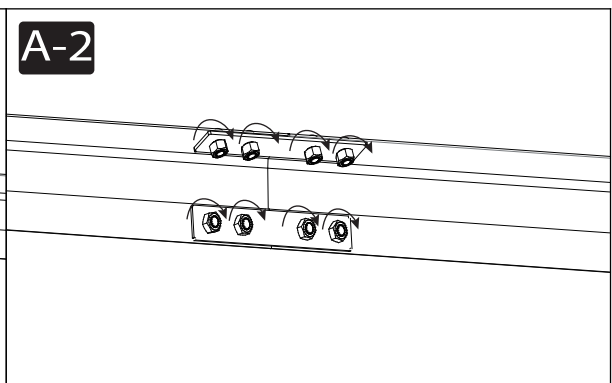
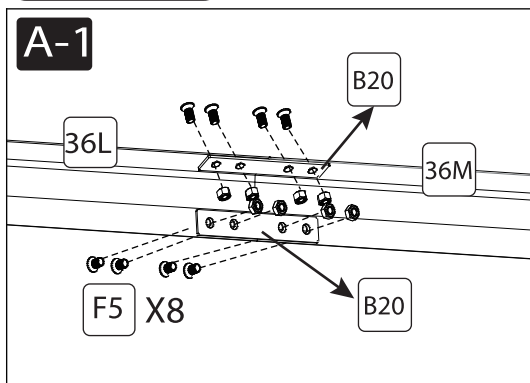

inside

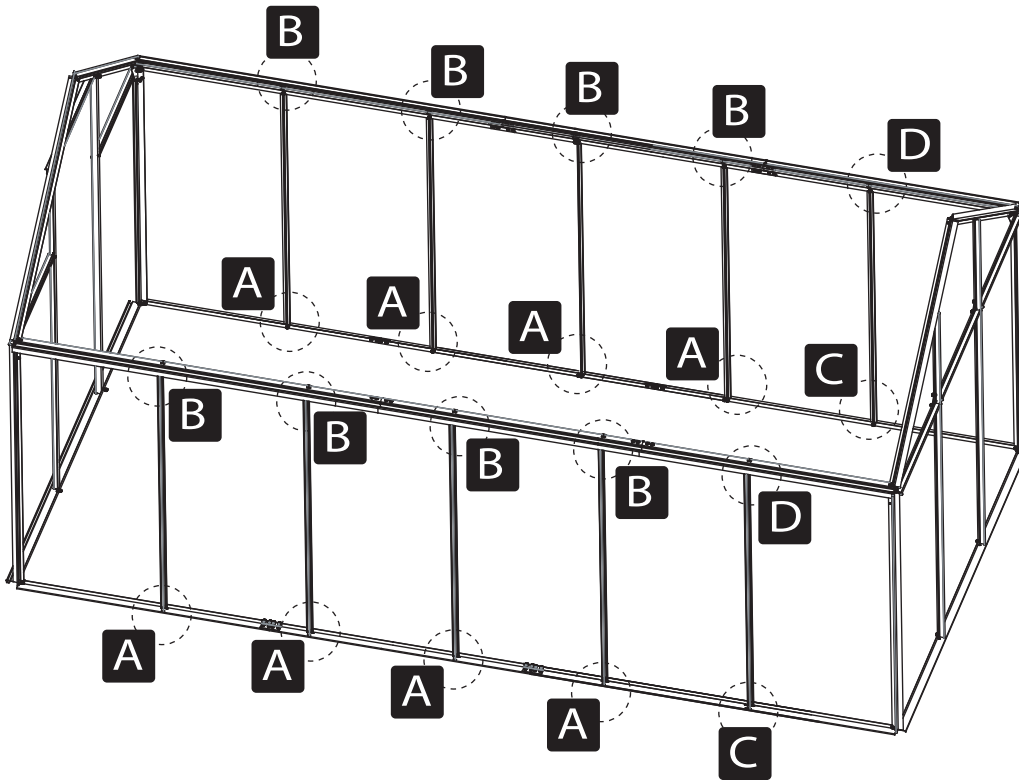
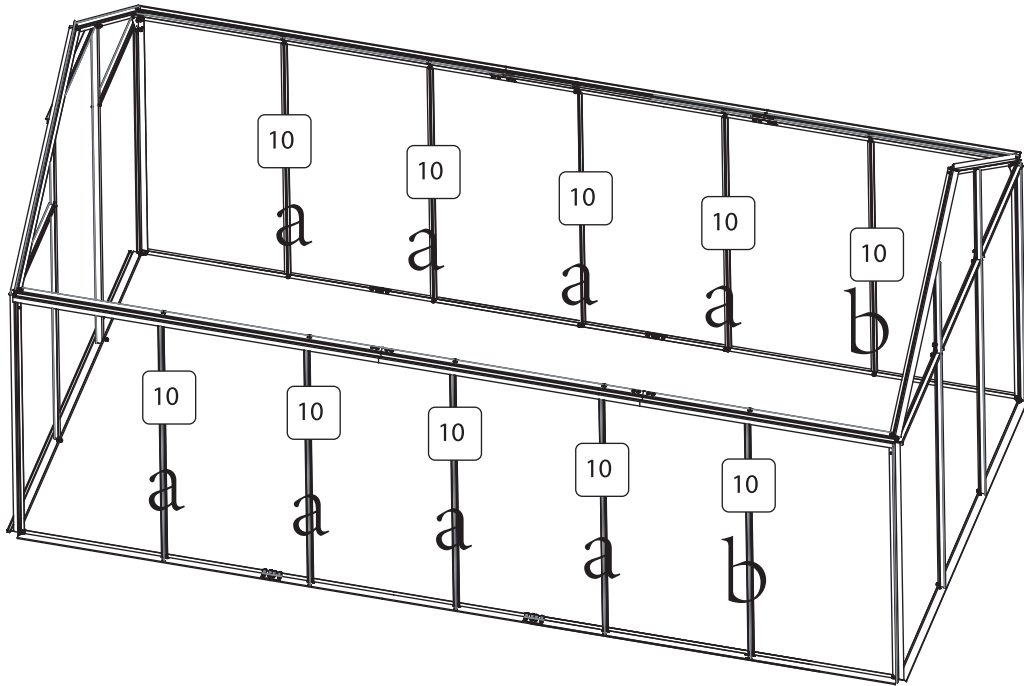

Part No.	Part	Qty.
36L		2
36R		2
36M		2
B20		8
F5		32
F10		8

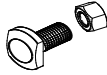

Part No.	Part	Qty.
10		10
F10		20
F10		18

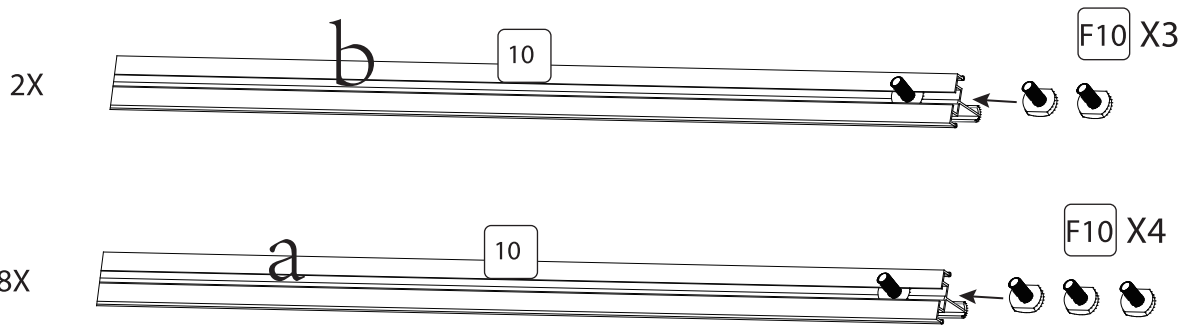

**Innen**

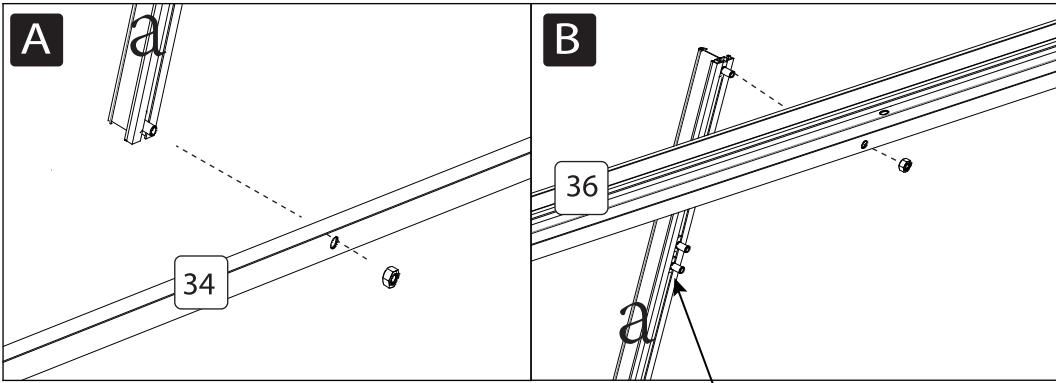

**EN**\_Reserve 2 pieces of F10 for installing 22 B26  
**FR**\_Réserver 2 pièces de F10 pour l'installation 22 B26  
**ES**\_Reservar 2 piezas de F10 para instalar 22 B26  
**PT**\_Reservar 2 peças de F10 para a instalação 22 B26  
**DE**\_Reservieren Sie 2 Stück F10 für den Einbau von 22 B26  
**IT**\_Riservare 2 pezzi di F10 per l'installazione di 22 B26  
**RO**\_Păstrați 2 bucăți de F10 pentru montarea a 22 de B26

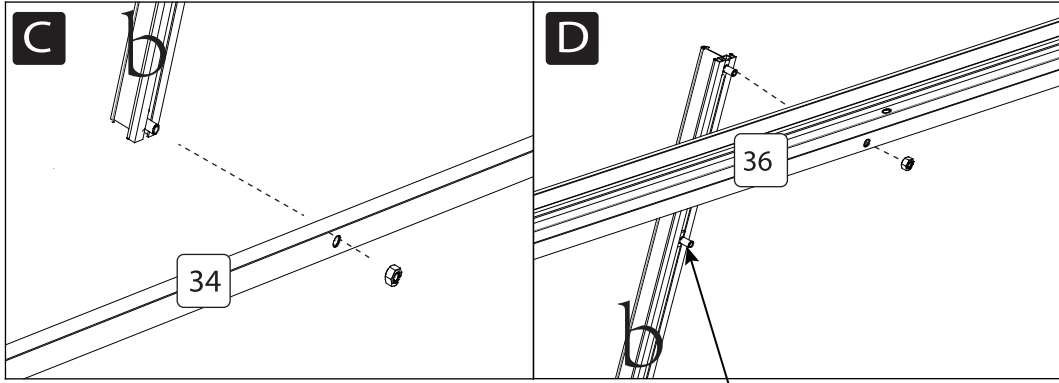



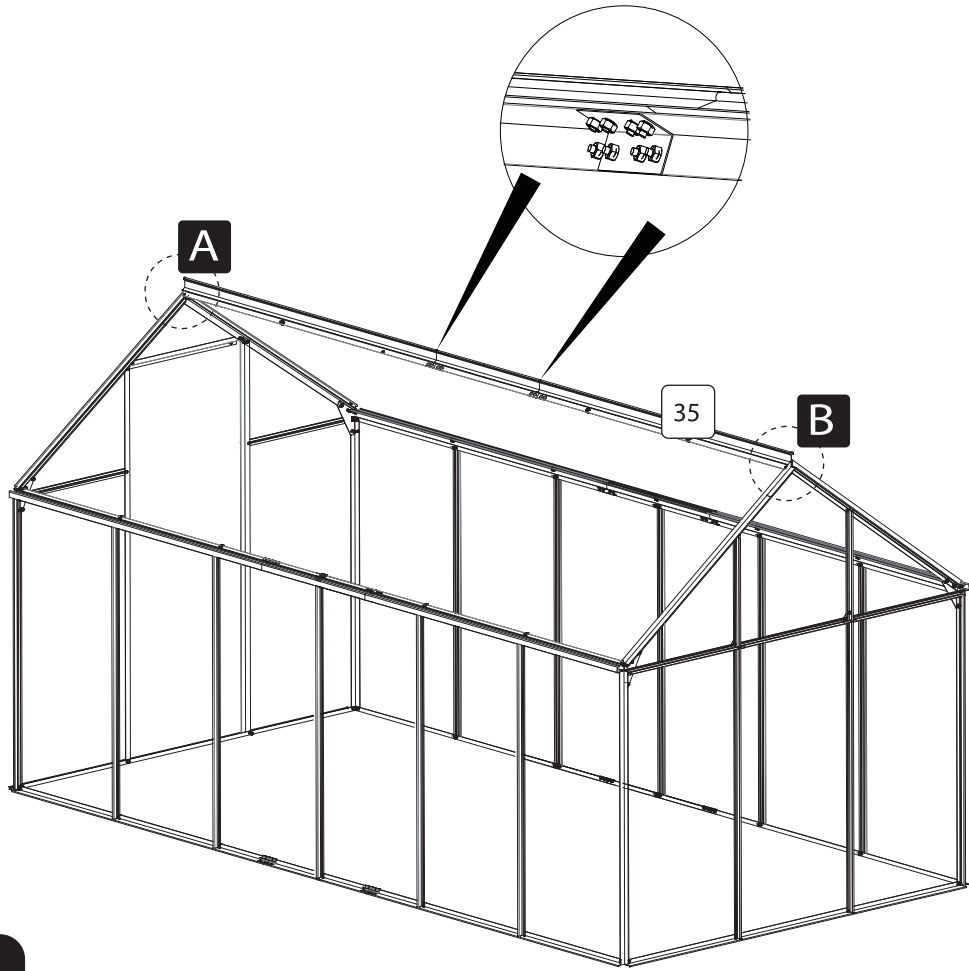

**EN**\_Reserve 1 pieces of F10 for installing B26  
**FR**\_Réserver 1 pièces de F10 pour l'installation B26  
**ES**\_Reservar 1 piezas de F10 para instalar B26  
**PT**\_Reservar 1 peças de F10 para a instalação B26  
**DE**\_Reservieren Sie 1 Stück F10 für den Einbau von B26  
**IT**\_Riservare 1 pezzi di F10 per l'installazione di B26  
**RO**\_Păstrați 1 bucată de F10 pentru montarea B26

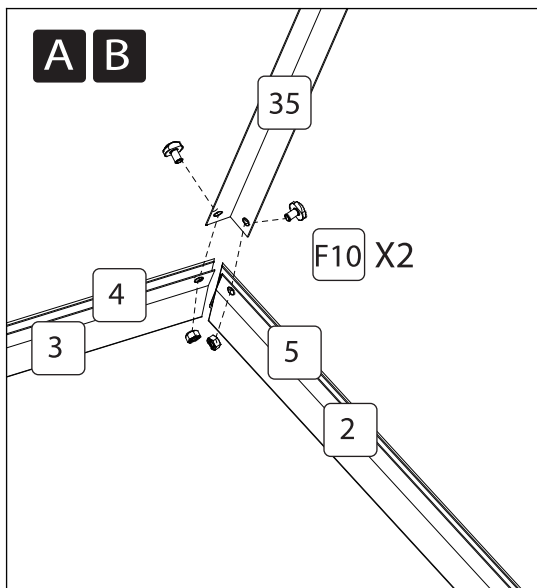
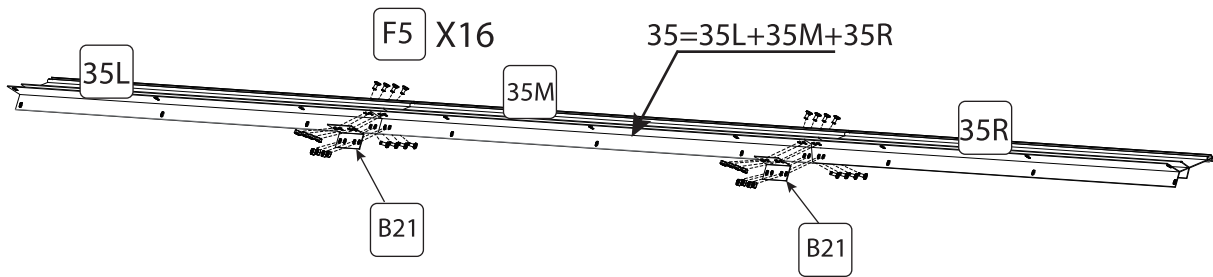

inside

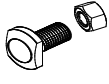
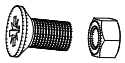

Part No.	Part	Qty.
35L		1
35R		1
35M		1
B21		2
F10		4
F5		16

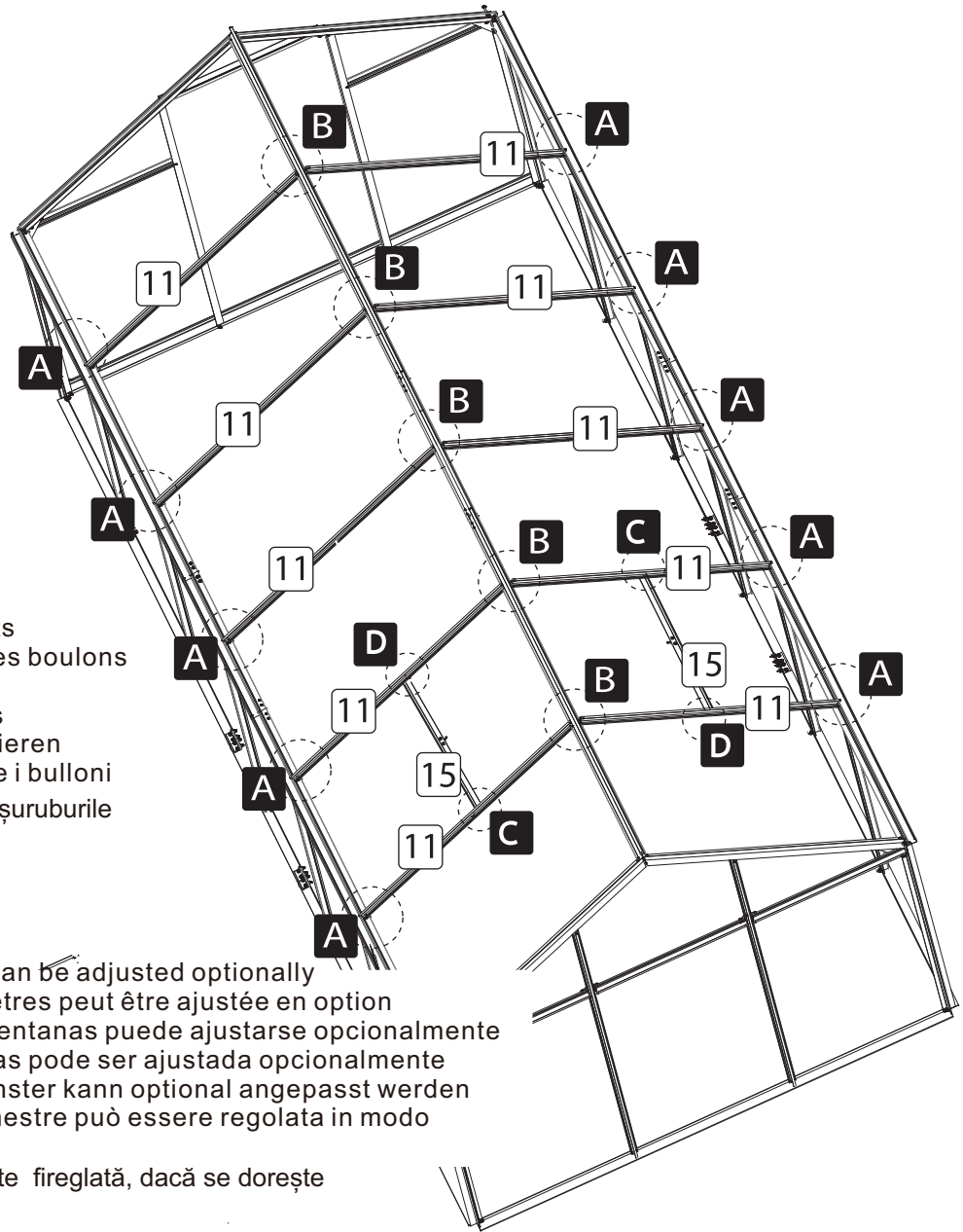





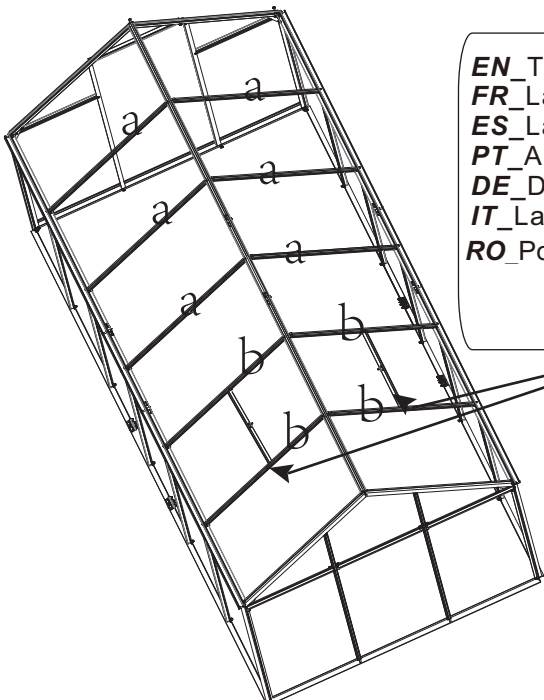

**EN\_** Please reserve bolts  
**FR\_** Veuillez réserver des boulons  
**ES\_** Reservar tornillos  
**PT\_** Reservar parafusos  
**DE\_** Bitte Bolzen reservieren  
**IT\_** Si prega di prenotare i bulloni  
**RO\_** Vă rugăm să păstrați șuruburile

**EN\_** Windows' position can be adjusted optionally  
**FR\_** La position des fenêtres peut être ajustée en option  
**ES\_** La posición de las ventanas puede ajustarse opcionalmente  
**PT\_** A posição das janelas pode ser ajustada opcionalmente  
**DE\_** Die Position der Fenster kann optional angepasst werden  
**IT\_** La posizione delle finestre può essere regolata in modo opzionale  
**RO\_** Poziția ferestrelor poate fi reglată, dacă se dorește

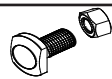

**EN\_** The position of window  
**FR\_** La position de la fenêtre  
**ES\_** La posición de la ventana  
**PT\_** A posição da janela  
**DE\_** Die Position des Fensters  
**IT\_** La posizione della finestra  
**RO\_** Poziția ferestrei

Part No.	Part	Qty.
11		10
15		2
B19		2
F4		4
F10		24
F10		20

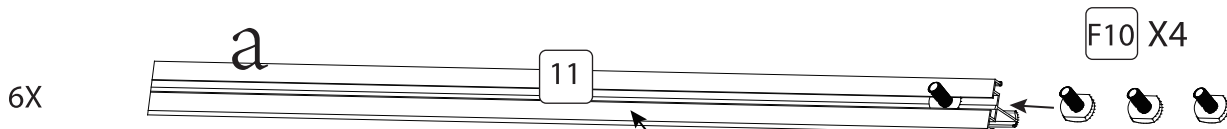

6X

**EN**\_Reserve 2 pieces of F10 for installing B26  
**FR**\_Réserver 2 pièces de F10 pour l'installation de B26  
**ES**\_Reserva 2 piezas de F10 para instalar B26  
**PT**\_Reservar 2 peças de F10 para a instalação de B26  
**DE**\_2 Stück F10 für den Einbau von B26 reservieren  
**IT**\_Riservare 2 pezzi di F10 per l'installazione di B26.  
**RO**\_Rezervați 2 bucăți de F10 pentru montarea modelului B26

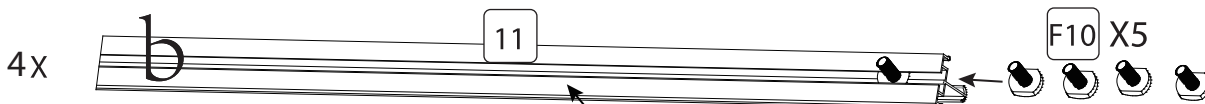

4X

**EN**\_Reserve 3 pieces of F10 for installing 15 B26  
**FR**\_Réserver 3 pièces de F10 pour l'installation de 15 B26  
**ES**\_Reserva 3 piezas de F10 para instalar 15 B26  
**PT**\_Reservar 3 peças de F10 para a instalação de 15 B26  
**DE**\_Reservieren Sie 3 Stück F10 für den Einbau von 15 B26  
**IT**\_Riserva di 3 pezzi di F10 per l'installazione di 15 B26  
**RO**\_Păstrați 3 bucăți de F10 pentru montarea a 15 bucăți de B26

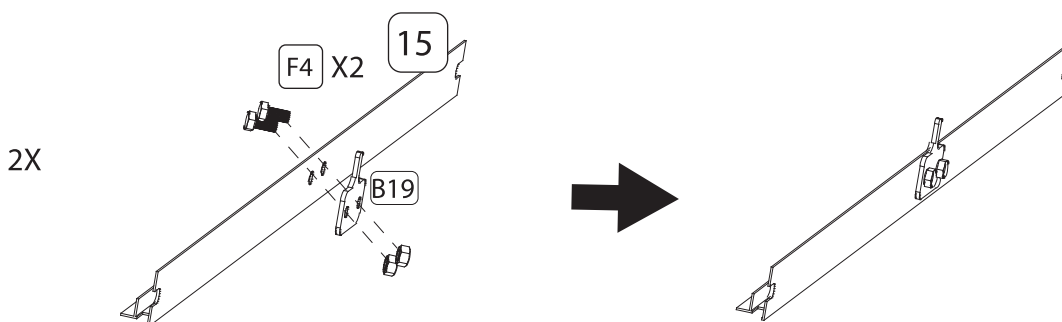

2X

**inside**

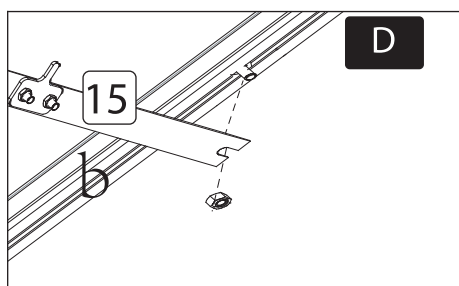
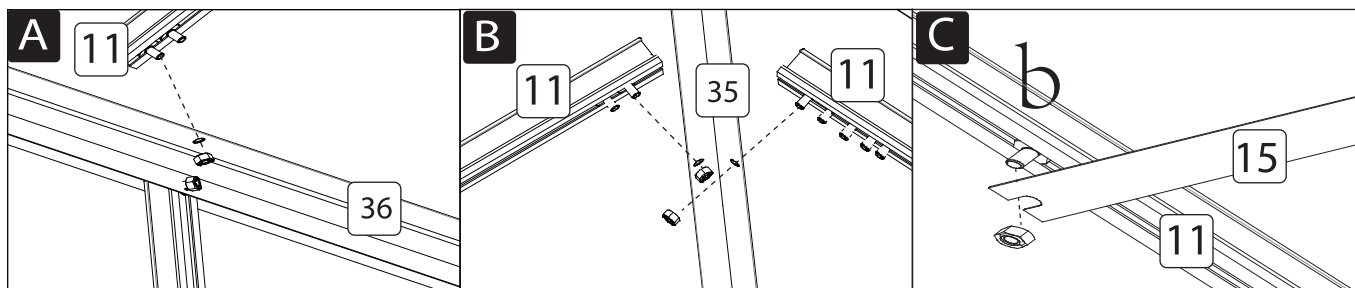

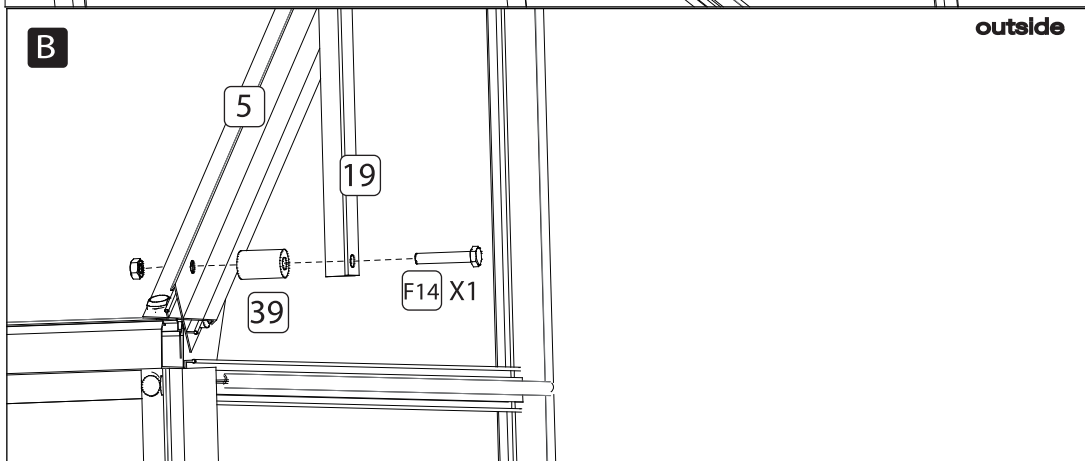
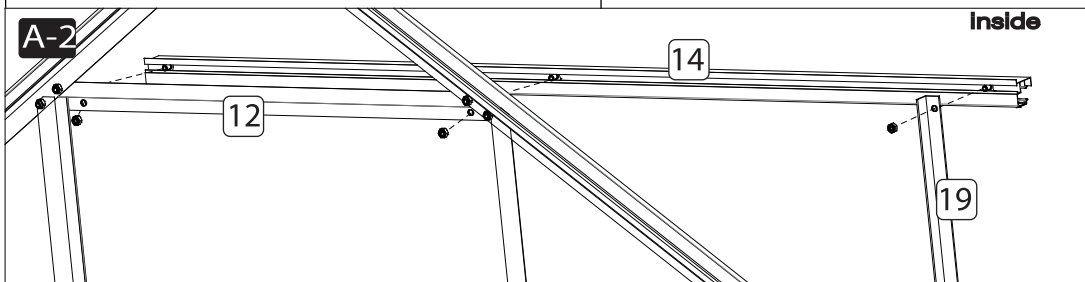
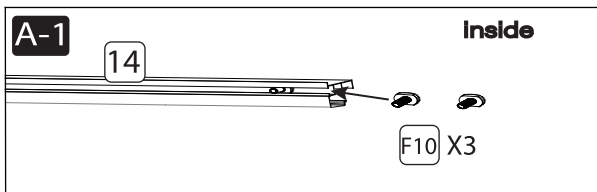
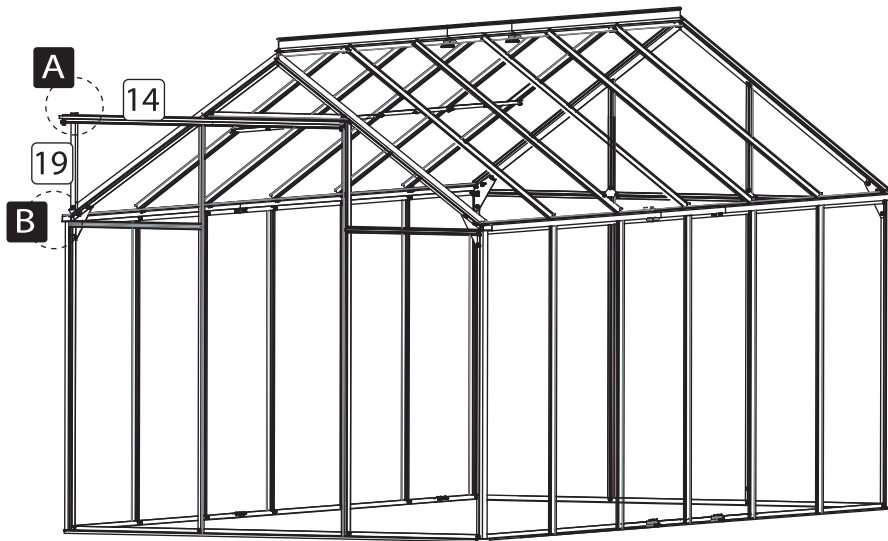

Part No.	Part	Qty.
14		1
19		1
39		1
F14		1
F10		3

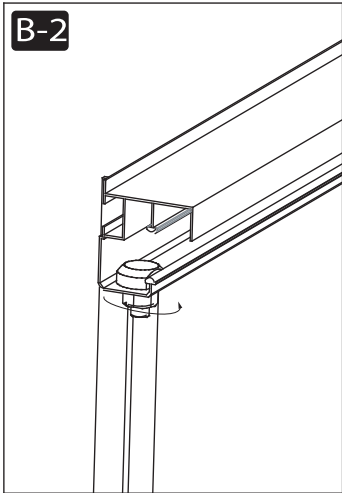
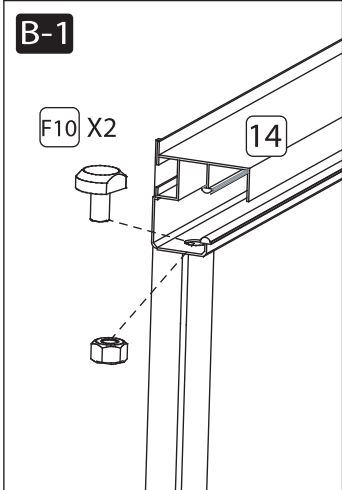
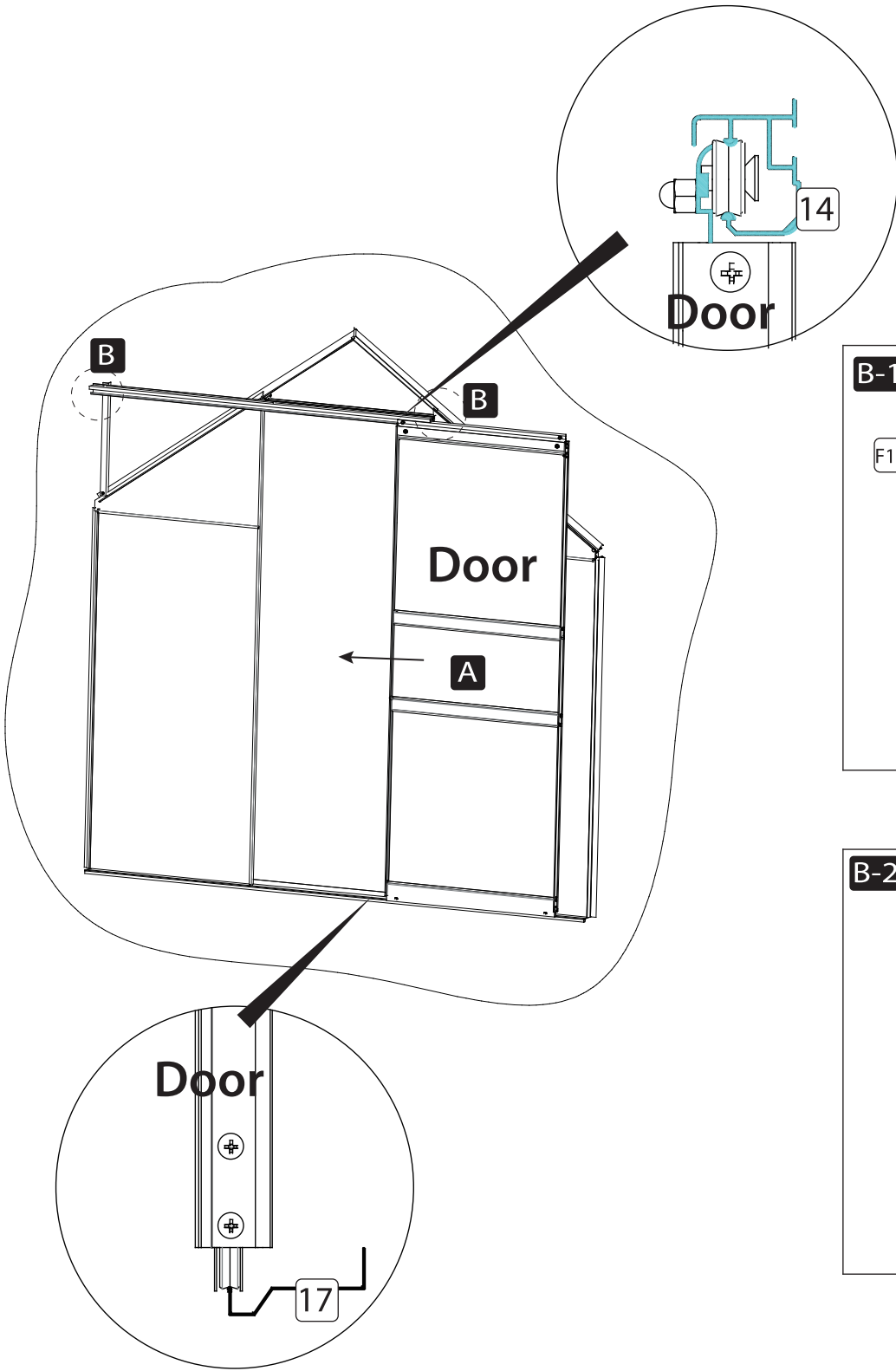

Part No.	Part	Qty.
F10		2

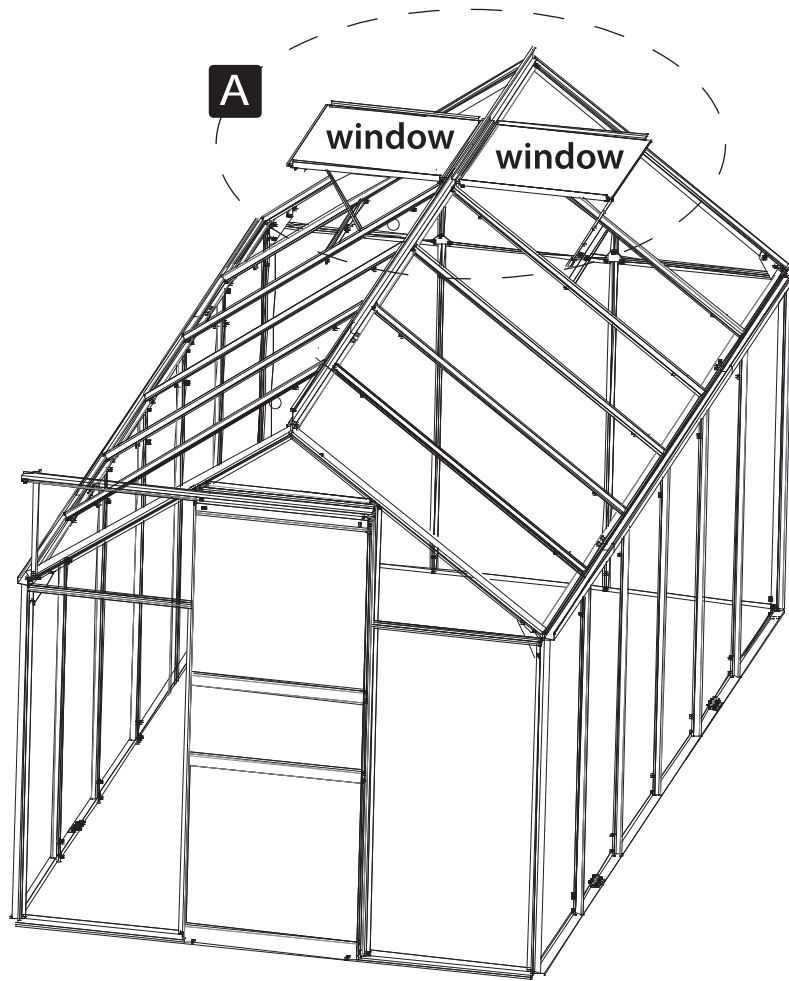
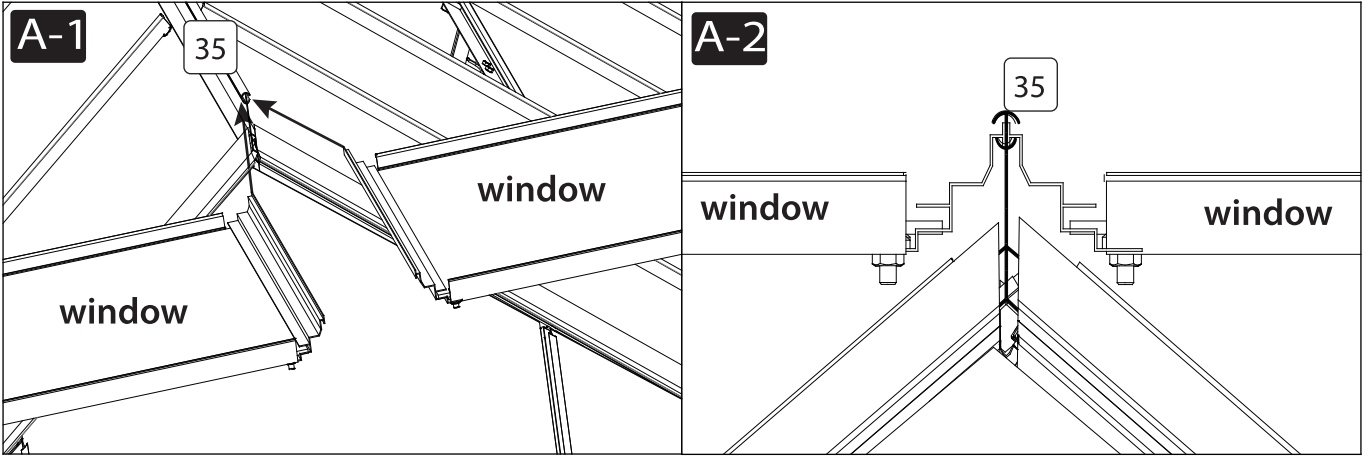

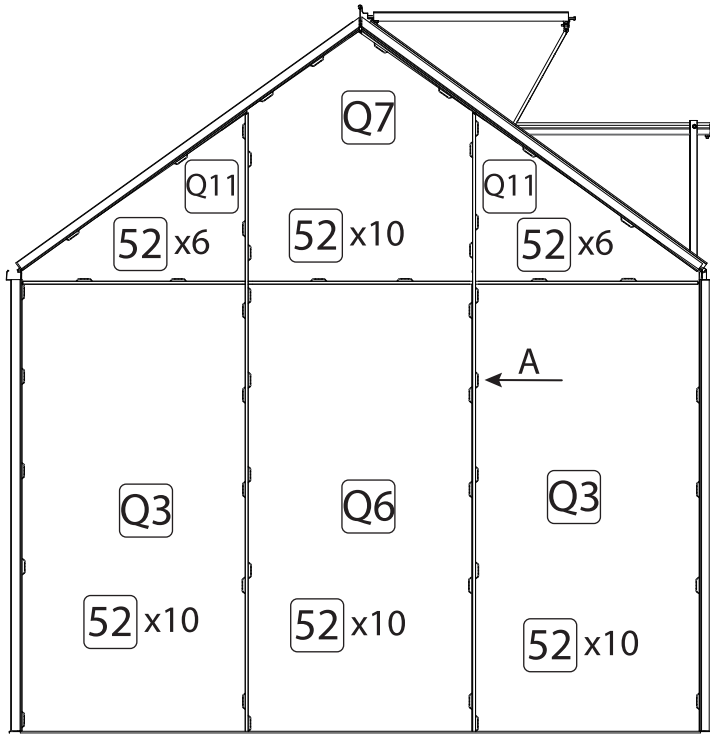

Rear

outside

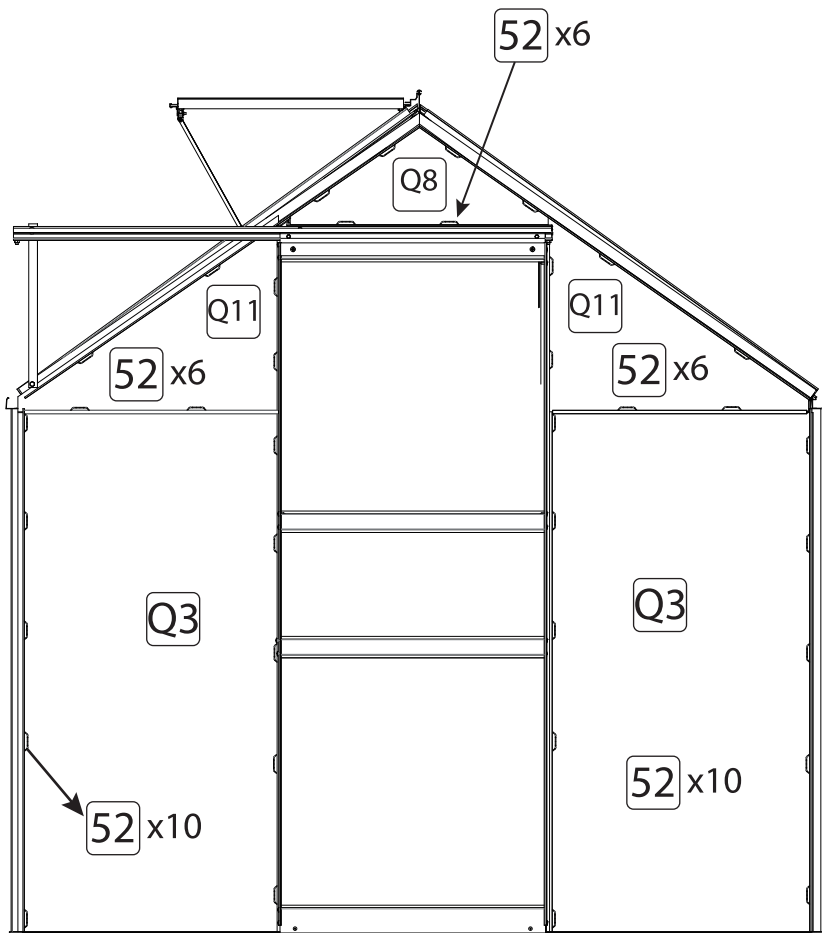
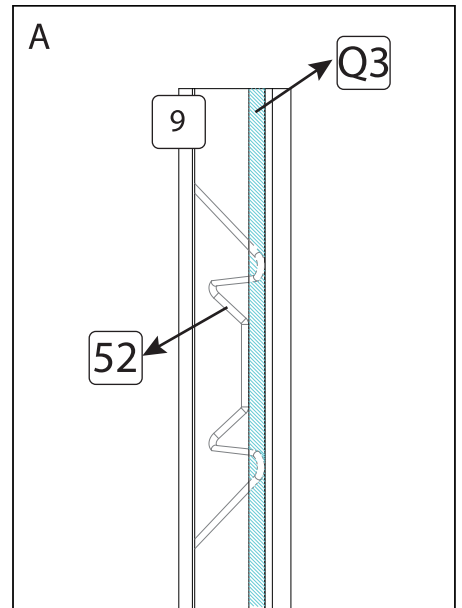

Front

Part No.	Part	Qty.
Q3		4
Q6		1
Q7		1
Q8		1
Q11		4
52		90

**outside**

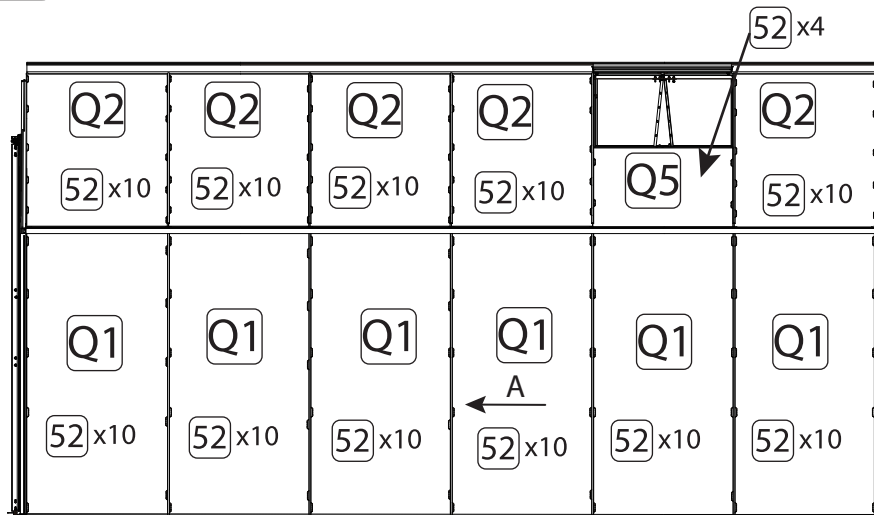

**Right**

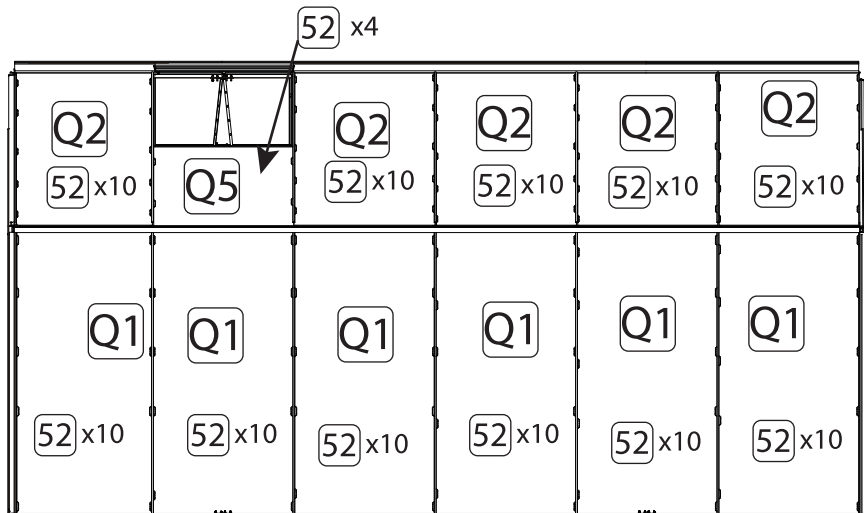

**Left**

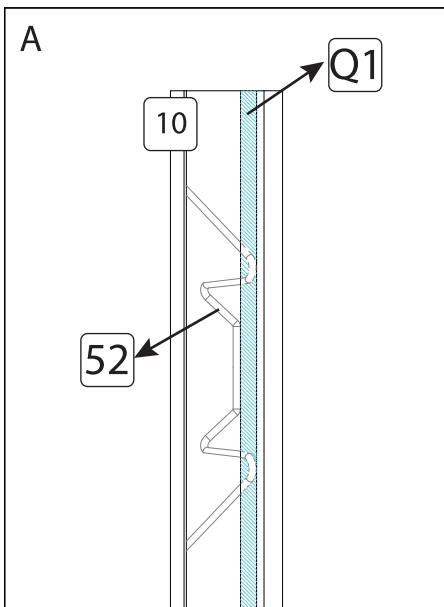

Part No.	Part	Qty.
Q1		12
Q2		8
Q5		4
52		228

inside

TOP

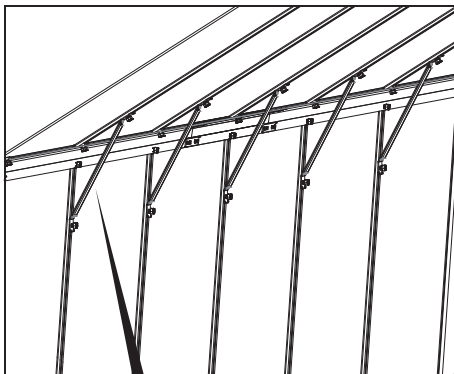
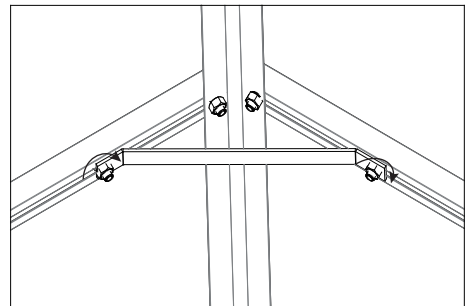
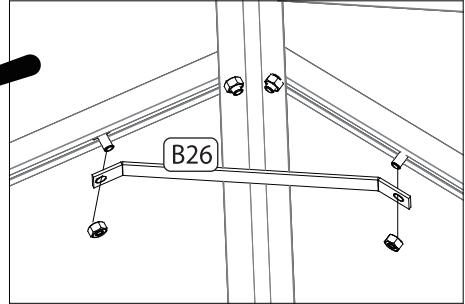
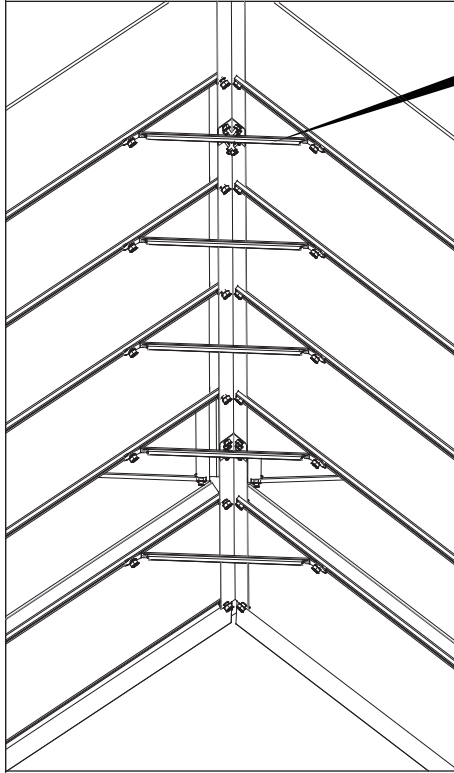

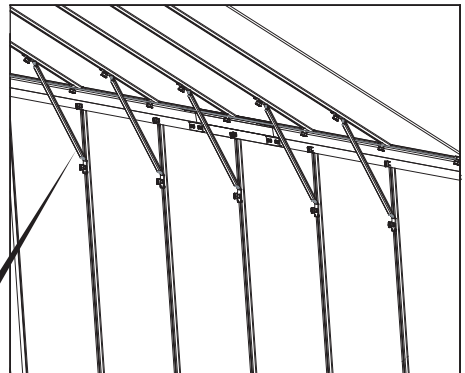

Left

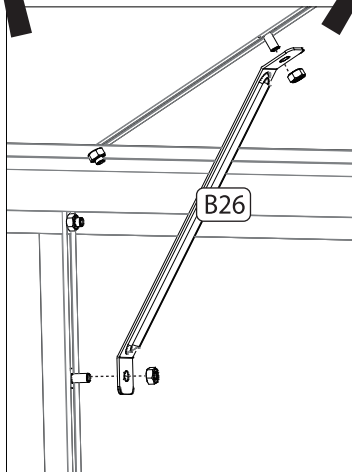

Right



Part No.	Part	Qty.
B26		15
F10		30

inside

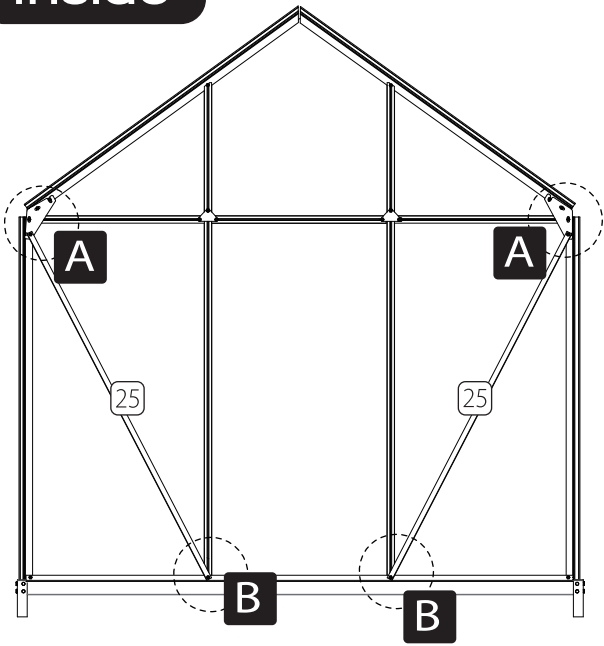

Rear

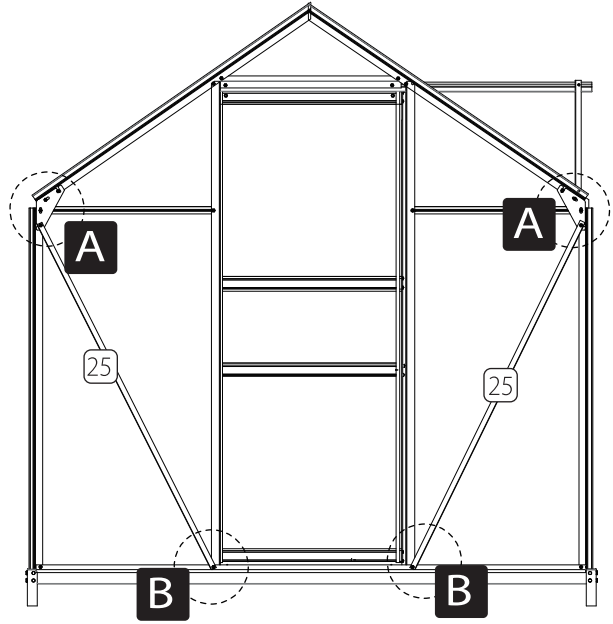

Front

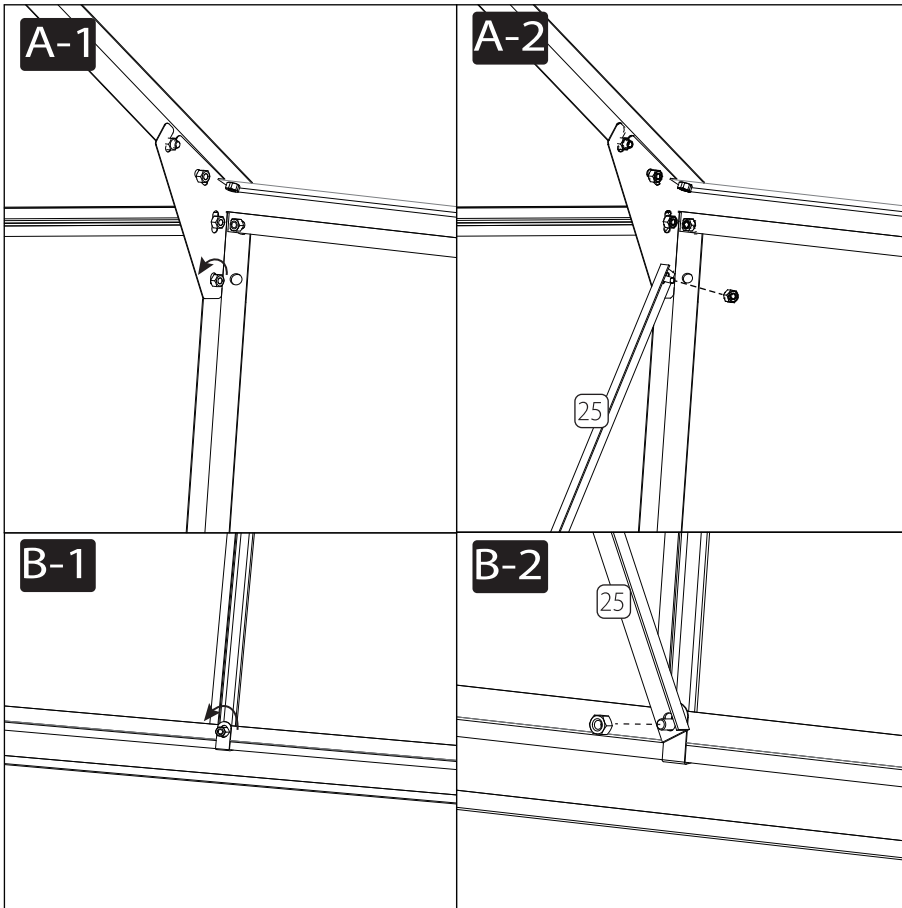





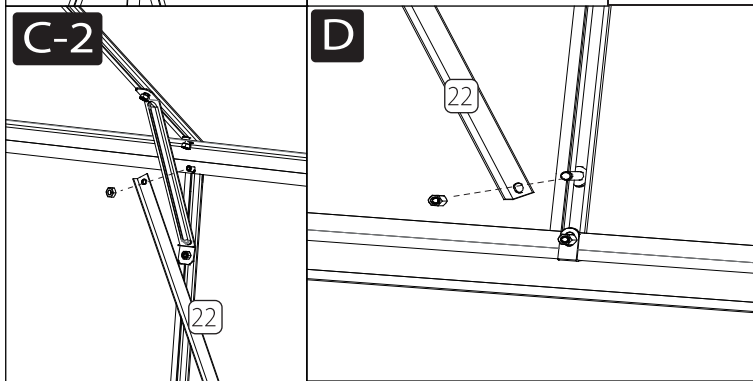
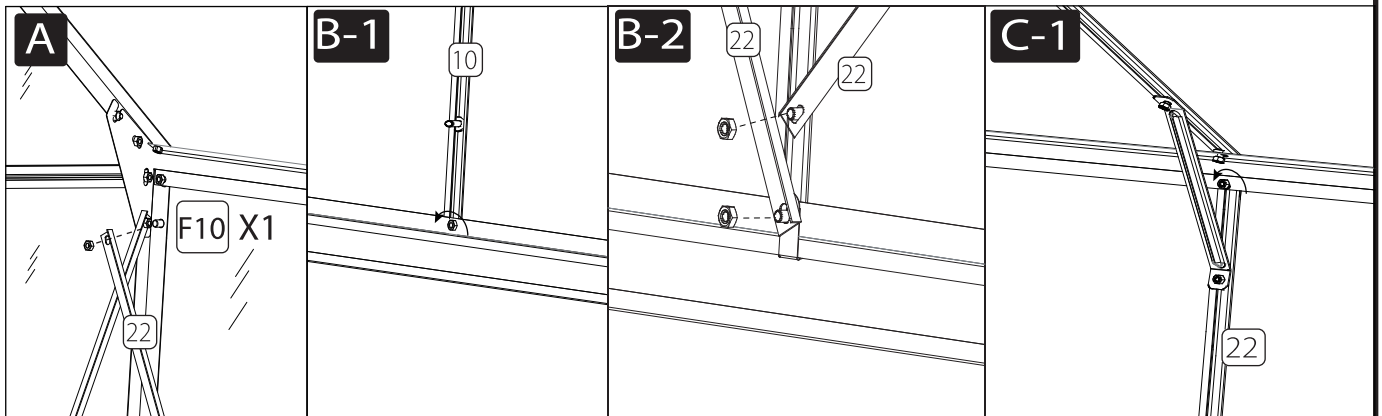
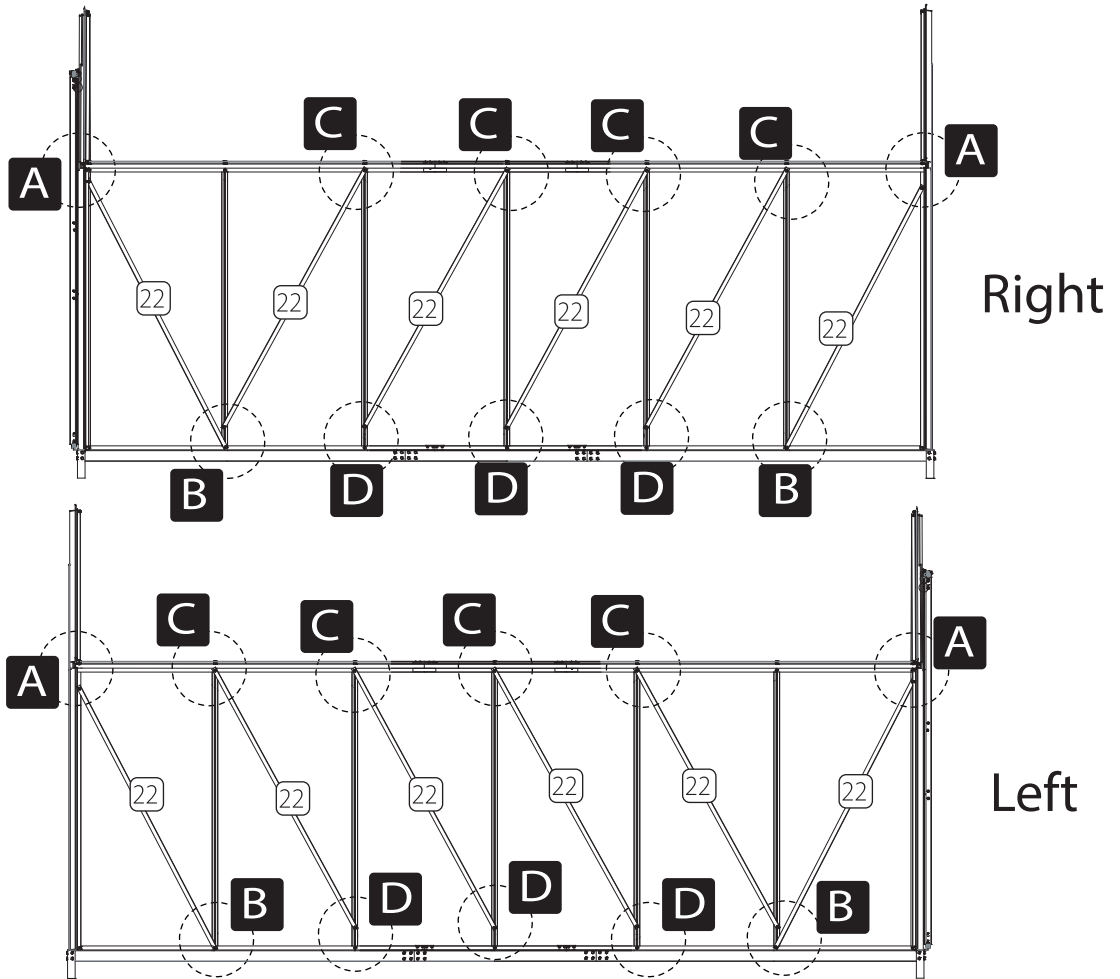

Part No.	Part	Qty.
25		4

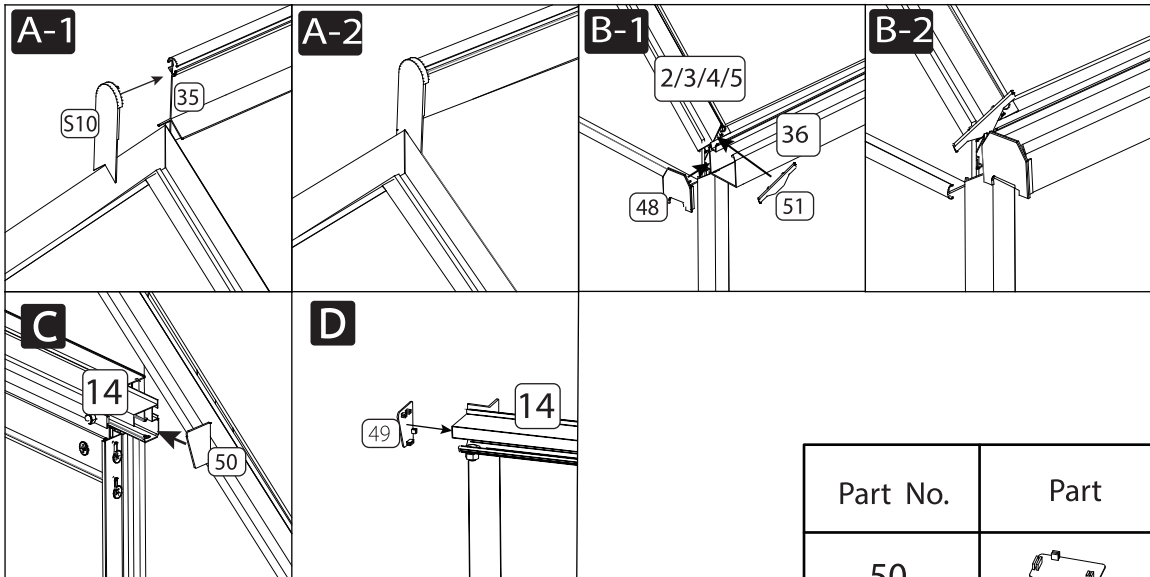
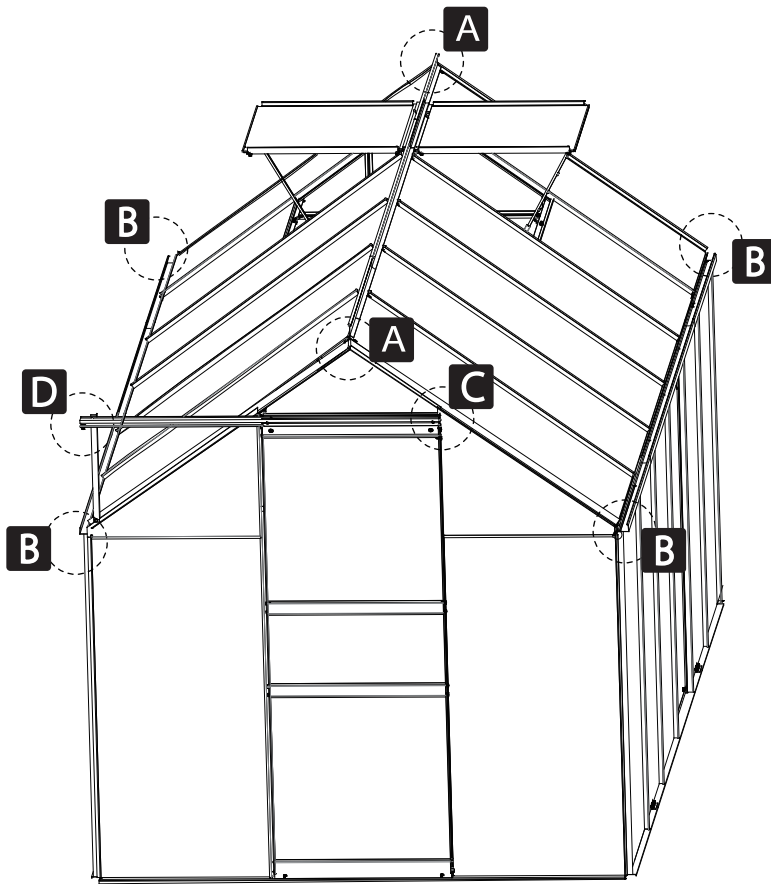
inside



Part No.	Part	Qty.
22		12
F10		4
F10		8



Part No.	Part	Qty.
50		1
49		1
S10		2
51		4
48		4

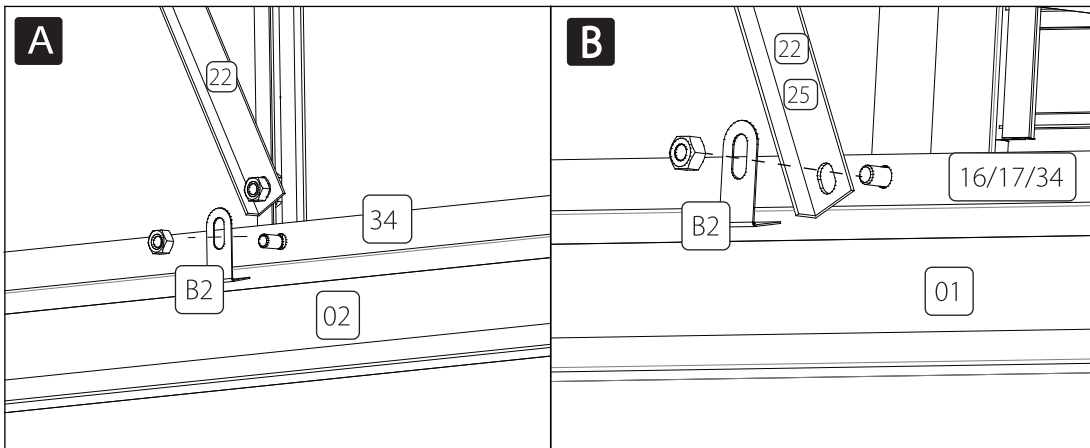
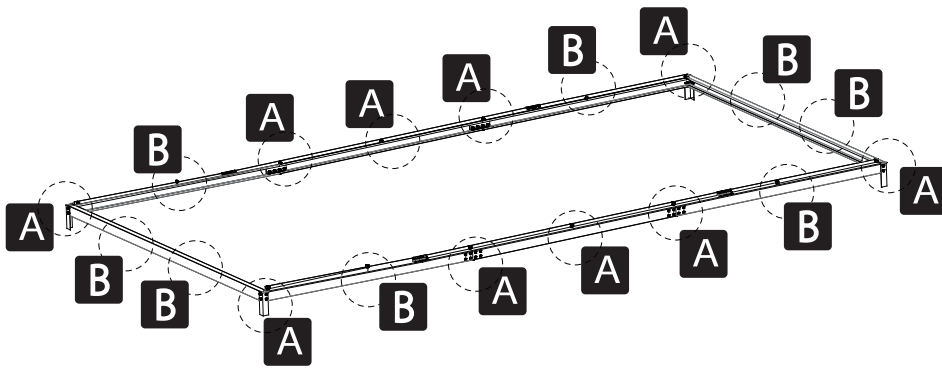
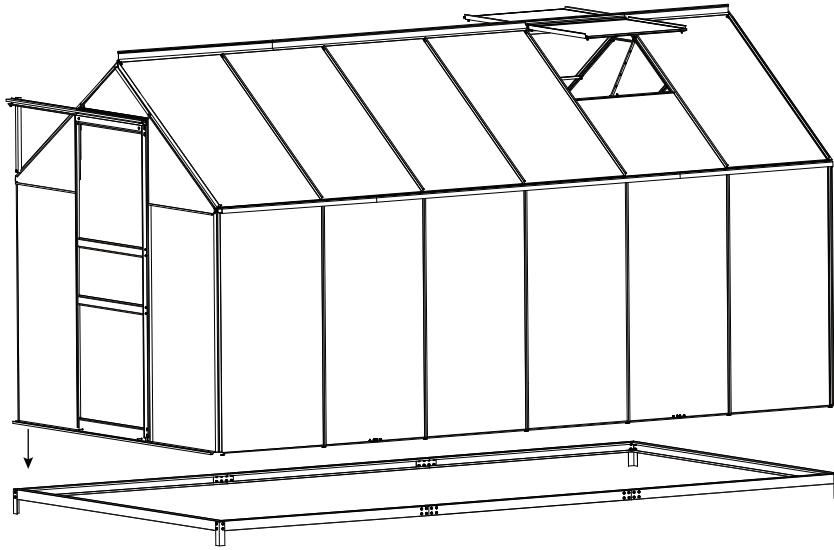

Part No.	Part	Qty.
B2		18

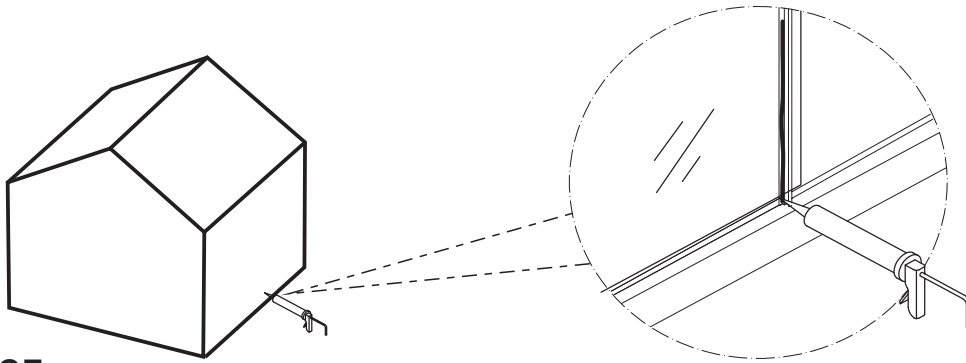

### **EN\_ADVICE**

It is not necessary but we would advise: For additional strength, you can also use some glue or tapes between the polycarbonate panel and the aluminium frame to enhance the stability.

Note: Silicone sealant and glue gun are not included in our tool kit. You can buy them locally. Only use silicone sealant suitable for aluminium

### **FR\_CONSEILS**

Ce n'est pas nécessaire mais nous vous conseillons:

Pour plus de solidité, vous pouvez également utiliser de la colle ou des rubans adhésifs entre le panneau en polycarbonate et le cadre en aluminium pour améliorer la stabilité.

Not : Le mastic silicone et le pistolet à colle ne sont pas inclus dans notre kit d'outils. Vous pouvez les acheter sur place. N'utilisez que du mastic silicone adapté à l'aluminium

### **ES\_CONSEJO**

No es necesario, pero le aconsejamos: Para mayor resistencia, también puede usar pegamento o cintas entre el panel de policarbonato y el marco de aluminio para mejorar la estabilidad.

Nota: El sellador de silicona y la pistola de pegamento no están incluidos en nuestro kit de herramientas. Puede comprarlos localmente. Sólo utilice el sellador de silicona adecuado para aluminio

### **PT\_ATENÇÃO**

Não é necessário, mas aconselhamos: Para uma resistência adicional, também se pode utilizar alguma cola ou fita adesiva entre o painel de policarbonato e a estrutura de alumínio para aumentar a estabilidade.

Nota: O selante de silicone e a pistola de cola não estão incluídos no nosso kit de ferramentas. Podem ser comprados localmente. Utilizar apenas selante de silicone adequado para alumínio

### **DE\_RAT**

Es ist nicht notwendig, aber wir würden vorschlagen: Um die Festigkeit zu erhöhen, können Sie auch etwas Kleber oder Klebeband zwischen der Polycarbonatplatte und dem Aluminiumrahmen verwenden, um die Stabilität zu verbessern.

Hinweis: Silikondichtmittel und Klebepistole sind nicht in unserem Werkzeugsatz enthalten. Sie können sie vor Ort kaufen. Verwenden Sie nur für Aluminium geeignetes Silikondichtmittel

### **IT\_SUGGERIMENTI**

Non è necessario ma consigliamo: Per una maggiore resistenza, puoi anche usare della colla o dei nastri tra il pannello in polycarbonato e la struttura in alluminio per migliorare la stabilità.

Nota: il sigillante siliconico e la pistola per colla non sono inclusi nel nostro kit di attrezzi.

Puoi acquistarli localmente. Utilizzare solo sigillante siliconico adatto per alluminio.

### **RO\_SFATURI**

Nu este obligatoriu, dar vă recomandăm: Pentru o rezistență sporită, puteți folosi și puțin adeziv sau bandă adezivă între panoul din policarbonat și cadrul din aluminiu, pentru a îmbunătăți stabilitatea.

Notă: Etanșantul siliconic și pistolul de lipit nu sunt incluse în trusa noastră de scule. Le puteți achiziționa de la magazinele locale. Folosiți numai etanșant siliconic adecvat pentru aluminiu

If you have any questions, please contact our customer care center, Our contact details are below:

**US**

 001-877-644-9366

 customerservice@aosom.com

Imported by Aosom LLC  
7777 Center Ave. Suite 430  
Huntington Beach, CA 92647-9998 USA  
MADE IN CHINA

Si tiene alguna pregunta, comuníquese con nuestro Centro de Atención al Cliente, Nuestros datos de contacto son los siguientes:

**ES**

 0034-931294512

 atencioncliente@aosom.es

IMPORTADOR/Fabricante/REP:  
SPANISH AOSOM, S.L.  
C/ROC GROS,Nº15.08550, ELS HOSTALETES DE  
BALENYÀ, SPAIN.  
B66295775  
HECHO EN CHINA

Se tiver alguma dúvida, por favor contacte o nosso Centro de Atendimento ao Cliente, Os nossos dados de contacto são os seguintes:

 0034-931294512

 info@aosom.pt.

IMPORTADOR/Fabricante/REP:  
SPANISH AOSOM, S.L.  
C.ROC GROS N.15, 08550. ELS HOSTALETES DE  
BALENYÀ  
FEITO NA CHINA

If you have any questions, please contact our customer care center, Our contact details are below:

**CA**

 416-792-6088

 customerservice@aosom.ca

Imported by Aosom Canada Inc.  
7270 Woodbine Avenue, Unit 307, Markham,  
Ontario Canada L3R 4B9  
MADE IN CHINA

Si vous avez la moindre question, veuillez contacter notre centre d'assistance à la clientèle, Nos coordonnées sont les suivantes:

 416-792-6088

 customerservice@aosom.ca

Importé par Aosom Canada Inc.  
7270 Woodbine Avenue, unité 307,  
Markham, Ontario Canada L3R 4B9  
FABRIQUÉ EN CHINE

In caso di dubbio, si prega di contattare il nostro centro assistenza clienti, I nostri dettagli di contatto sono di seguito:

**IT**

 0039-0249471447

 clienti@aosom.it

IMPORTATO DA/Produttore/REP:  
AOSOM Italy srl  
Centro Direzionale Milanofiori  
Strada 1 Palazzo F1  
20057 Assago (MI)  
P.I.: 08567220960  
FATTO IN CINA

If you have any questions, please contact our customer care center, Our contact details are below:

**UK**

 0044-800-240-4004

 enquiries@mhstar.co.uk

IMPORTER ADDRESS:  
MH STAR UK Ltd  
1 Northampton Cross Logistics Park  
Northampton Cross Road  
Northampton  
NN4 9FH  
MADE IN CHINA

Wenn Sie Fragen haben, wenden Sie sich bitte an unser Kundendienstzentrum, Unsere Kontaktdaten stehen unten:

**DE**

 0049-0(40)-87408465

 service@aosom.de

ADRESSE DES IMPORTEURE/Hersteller/REP:  
MH Handel GmbH  
Wendenstraße 309  
D-20537 Hamburg  
Germany  
IN CHINA HERGESTELLT

Si vous avez la moindre question, veuillez contacter notre centre d'assistance à la clientèle, Nos coordonnées sont les suivantes:

**FR**

 0033-1-84166106

 aosom@mhfrance.fr

Importé par/Fabricant/REP:  
MH FRANCE  
2 Rue Maurice Hartmann  
92130 Issy Les Moulineaux  
France  
FABRIQUÉ EN CHINE



**FR**

**DONNEZ  
OU  
RECYCLEZ**



ASSOCIATION

OU



LIVRAISON

OU



DÉCHÈTERIE

Adresses sur [quefairedemesdechets.fr](http://quefairedemesdechets.fr)