

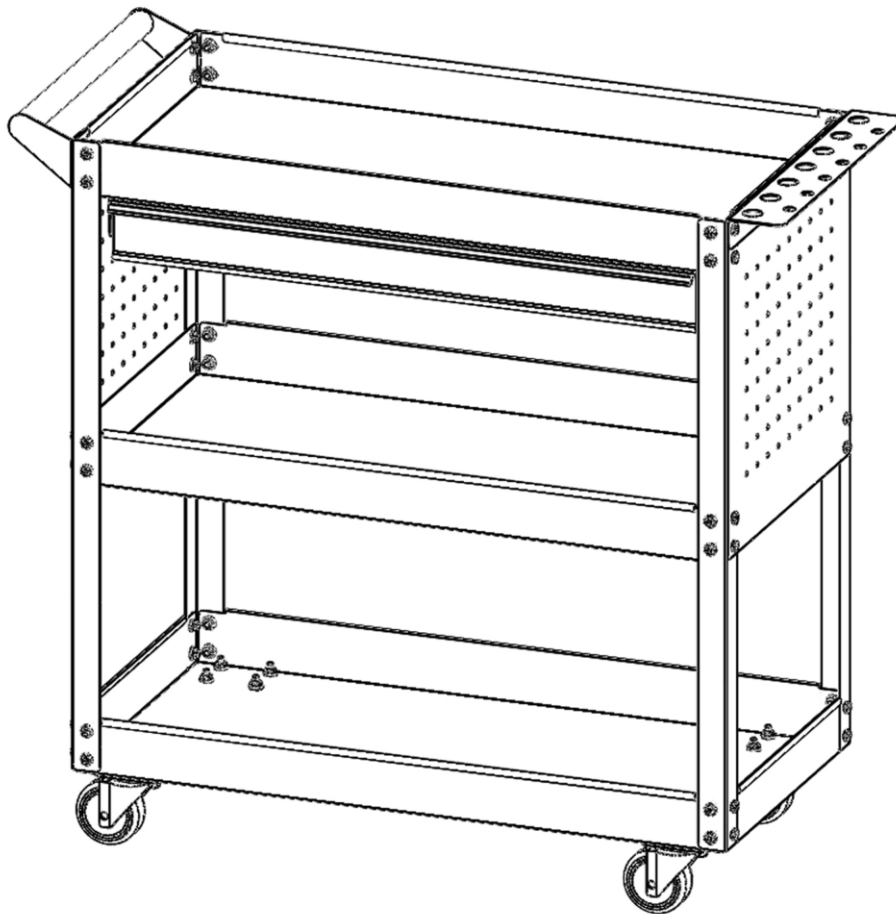

IN230300375V01

B20-065 _ B20-065V00

EN_ IMPORTANT, RETAIN FOR FUTURE REFERENCE: READ CAREFULLY.

FR_ IMPORTANT: A LIRE ATTENTIVEMENT ET À CONSERVER POUR CONSULTATION ULTÉRIEURE.

ES_ IMPORTANTE, LEA Y GUARDE PARA FUTURAS REFERENCIAS.

PT_ IMPORTANTE: LEIA ATENTAMENTE E GUARDE PARA CONSULTA FUTURA.

DE_ WICHTIG! SORGFÄLTIG LESEN UND FÜR SPÄTER NACHSCHLAGEN AUFBEWAHREN.

IT_ IMPORTANTE! CONSERVARE IL PRESENTE MANUALE PER FUTURO RIFERIMENTO E LEGGERLO ATTENTAMENTE.

RO_ IMPORTANT: CITIȚI CU ATENȚIE ȘI PĂSTRAȚI PENTRU CONSULTARE VIITOARE.

PARTS

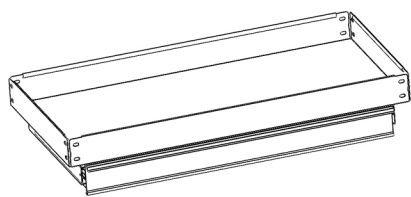

1 x 1



2 x 1

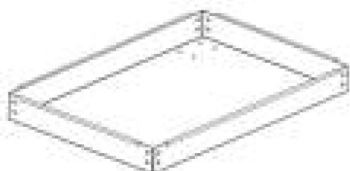

3 x 1

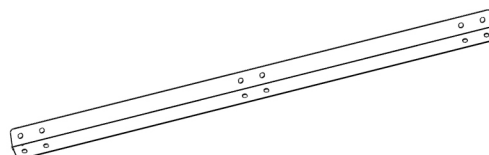

4 x 4

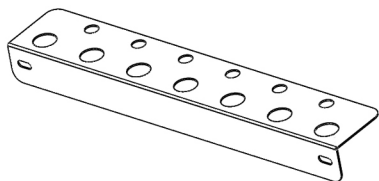

5 x 1

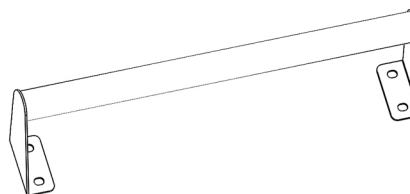

6 x 1

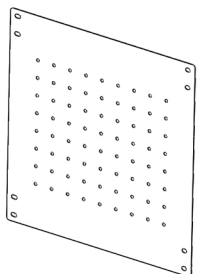

7 x 2

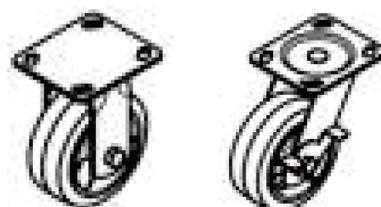

8 x 2

HARDWARE



A x48
+1(spare)



B x64
+1(spare)

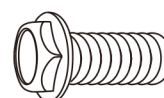

C x16
+1(spare)

Using four Carriage Bolts, four Washers for Caster, and four Hex Nuts for Caster, attach Swivel Caster to the next corner of the Bottom Shelf and last, follow the same directions for the final Swivel Caster. (Figure 1)

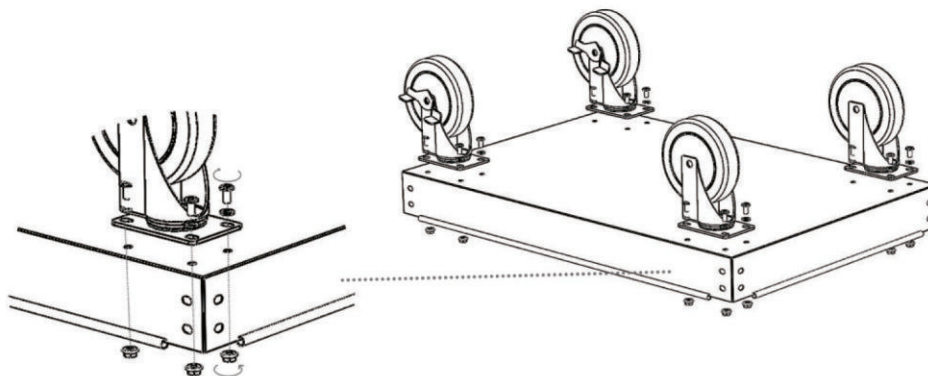

(Figure 1)

Note: "Like" Casters should be attached to each corner of the narrow sides of the Bottom Shelf. There are two Swivel Casters (free rolling), and two swivel Casters w/Brake. (Figure 1)

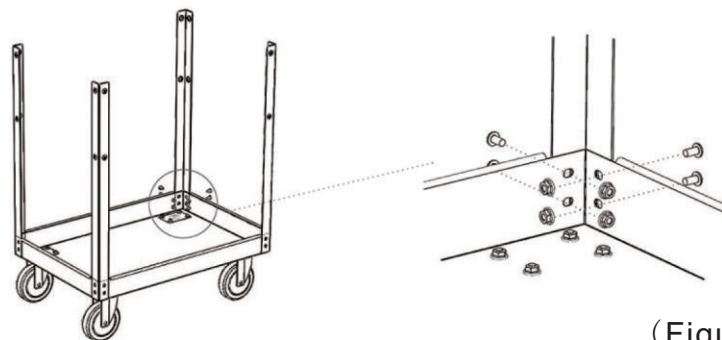

(Figure 2)

Using Carriage Bolts, and Hex Nut, attach the Corner Frame to each of the four corners of the Bottom Shelf. (Figure 2)

NOTE: Pay close attention to the assembly direction of the Corner Frames. It is possible to install them upside down. This would have to be corrected before the assembly could be completed. The first hole in the top/upside measures 1.38" from the end. The first hole in the downside/bottom measures 1.02" from its end. (Figure 2)

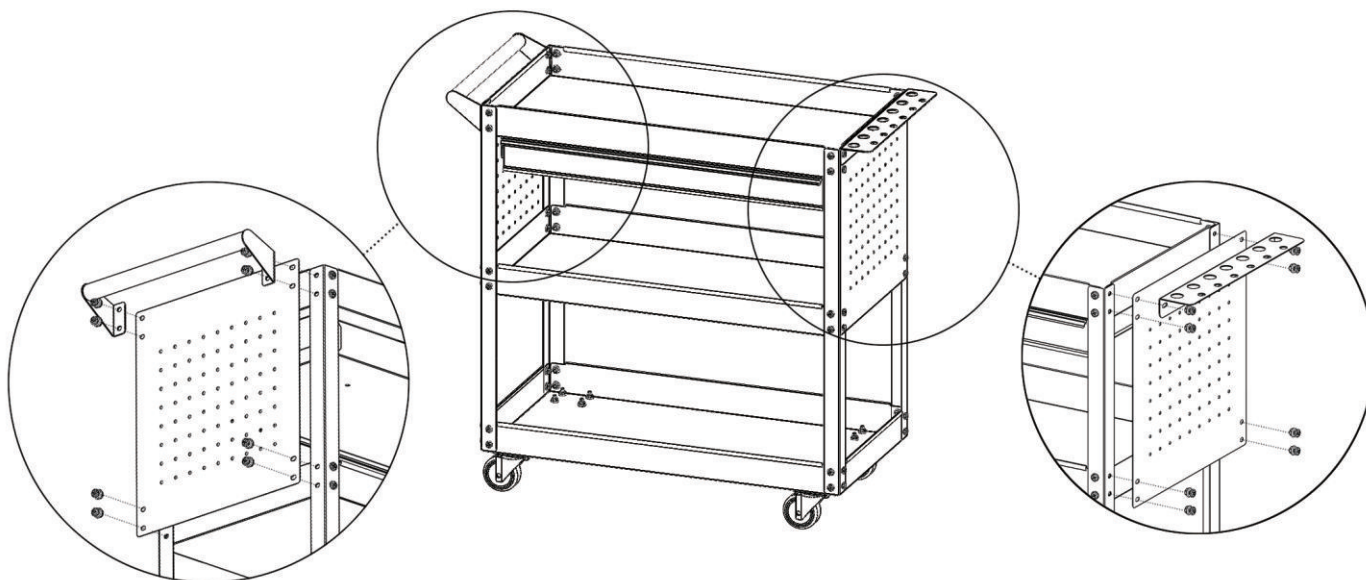

À l'aide de quatre boulons de carrosserie, de quatre rondelles pour la roulette et de quatre écrous hexagonaux pour la roulette, fixez la roulette pivotante à l'angle suivant de l'étagère inférieure et, enfin, suivez les mêmes instructions pour la dernière roulette pivotante (figure 1).

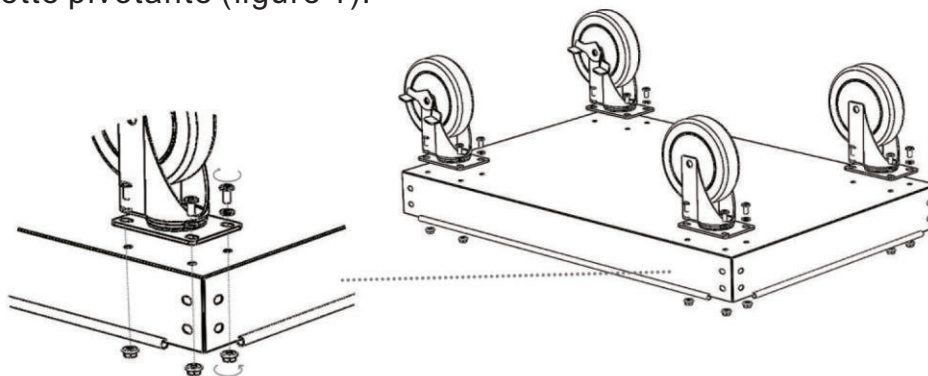

(Figure 1)

Remarque : des roulettes "similaires" doivent être fixées à chaque coin des côtés étroits de l'étagère inférieure. Il y a deux roulettes pivotantes (à roulement libre) et deux roulettes pivotantes avec frein (figure 1).

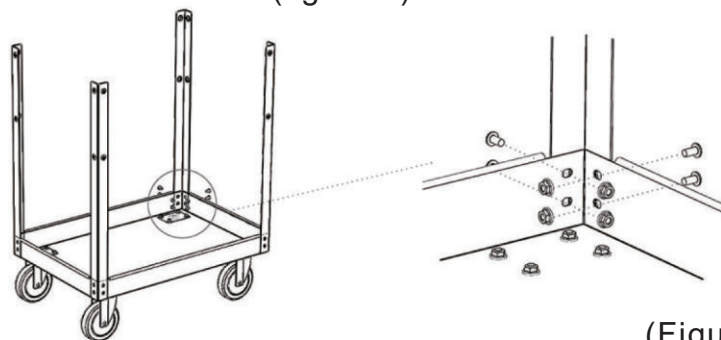

(Figure 2)

A l'aide de boulons de carrosserie et de vis hexagonales, fixez les cadres d'angle à chacun des quatre coins de l'étagère inférieure (figure 2).

REMARQUE : Faites très attention au sens d'assemblage des cadres d'angle, car il est possible de les installer à l'envers, ce qui devra être corrigé avant de terminer l'assemblage. Il est possible de les installer à l'envers, ce qui devra être corrigé avant que l'assemblage puisse être terminé. Le premier trou du côté inférieur mesure 1,02" à partir de l'extrémité (figure 2).

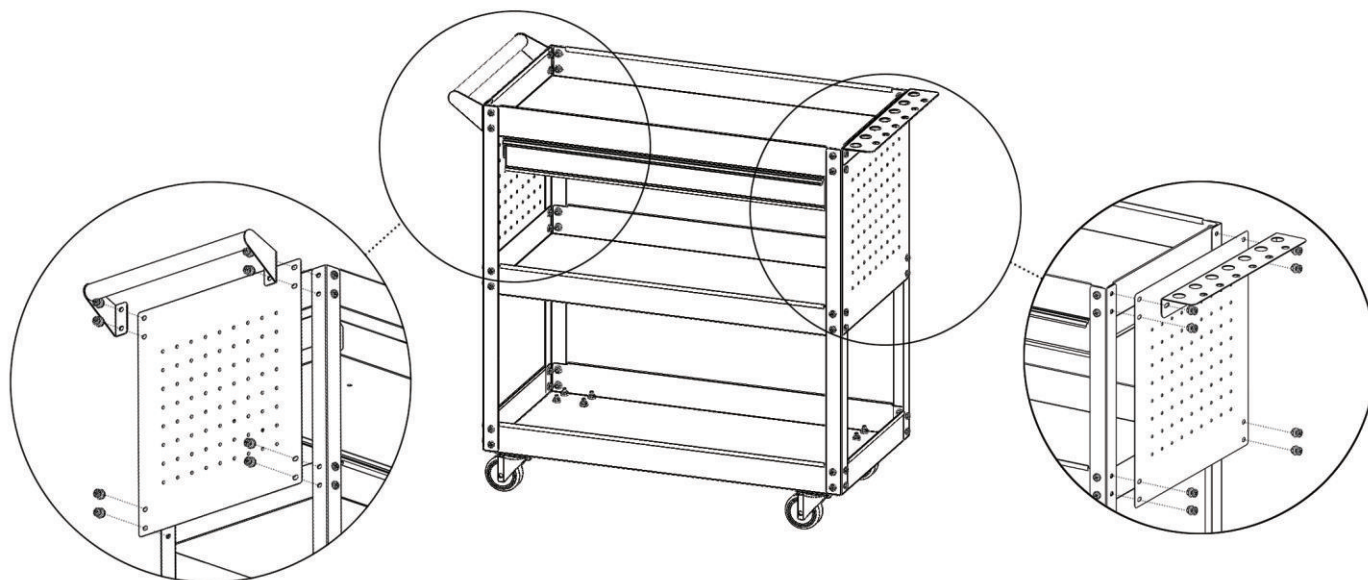

Usando cuatro tornillos de carruaje, cuatro arandelas y cuatro tuercas hexagonales, fije la rueda giratoria a la siguiente esquina del estante inferior y, por último, siga las mismas instrucciones para la rueda giratoria final (Figura 1).

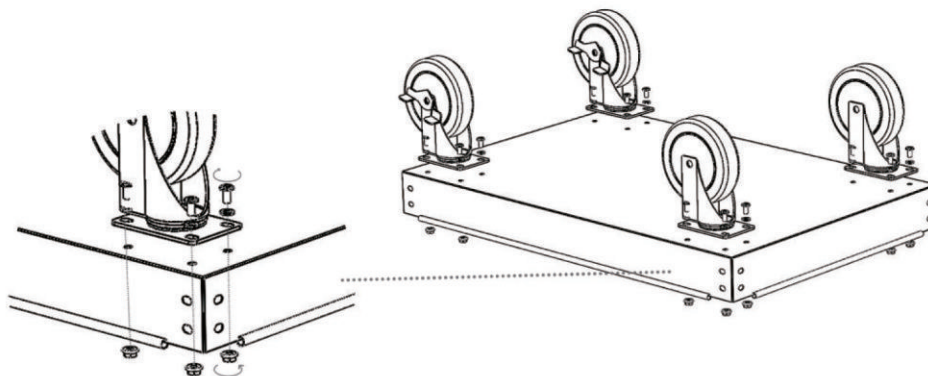

(Figura 1)

Nota: Las ruedas deben colocarse en cada esquina de los lados estrechos de la balda inferior. Hay dos ruedas giratorias (de giro libre) y dos ruedas giratorias con freno (Figura 1).

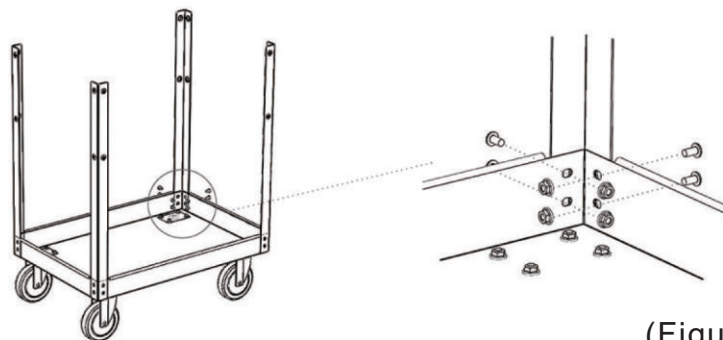

(Figura 2)

Fije los marcos esquineros a cada una de las cuatro esquinas de la balda inferior con pernos y tornillos hexagonales (figura 2).

NOTA: Preste mucha atención a la dirección de montaje de los marcos esquineros, ya que es posible que se instalen al revés. El primer agujero en la parte superior/arriba mide 1,38" desde el extremo. El primer orificio en la parte inferior mide 1,02" desde su extremo (figura 2).

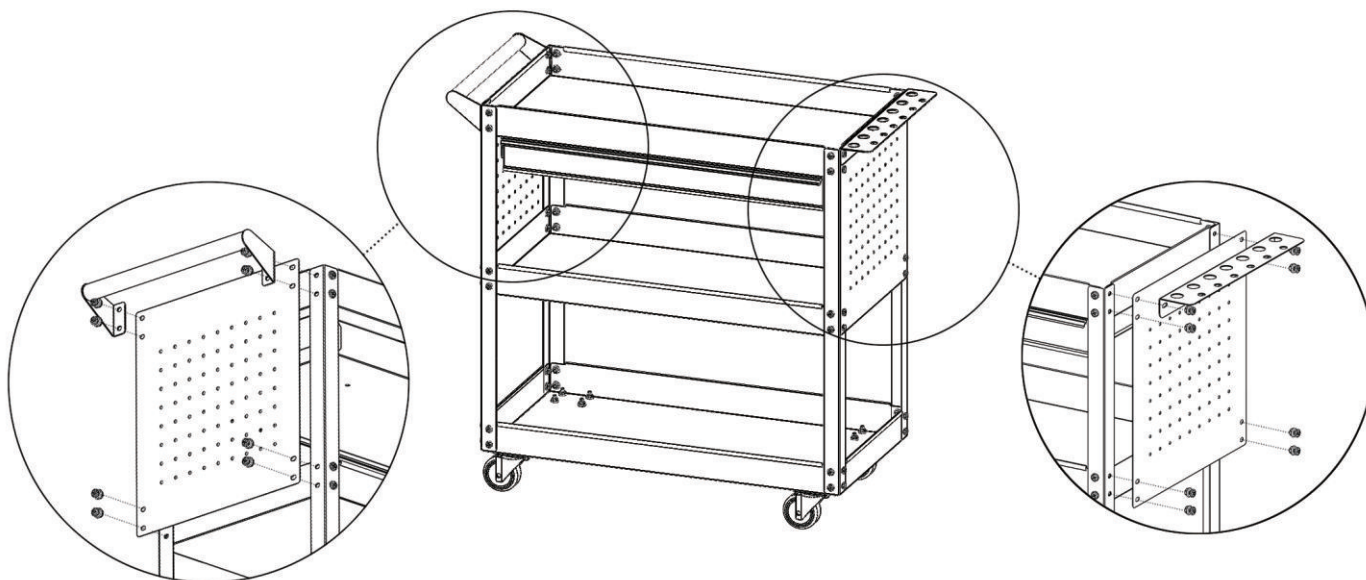

Utilizando quatro Parafusos de Transporte, quatro Anilhas para Rodízio, e quatro Porcas Sextavadas para Rodízio, prenda o Rodízio Giratório ao canto seguinte da Prateleira Inferior e por último, siga as mesmas direcções para o Rodízio Giratório final. (Figura 1)

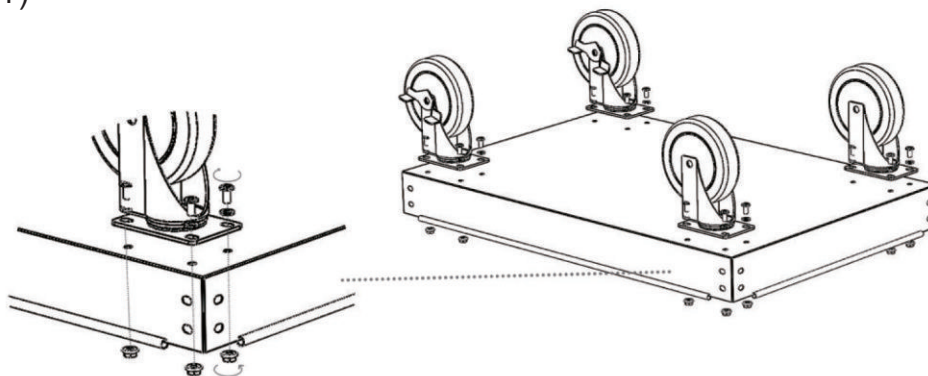

(Figura 1)

Nota: "Como" as rodas devem ser fixadas a cada canto dos lados estreitos da Prateleira inferior. Existem duas rodas giratórias (rolagem livre), e duas rodas giratórias c/ travão (Figura 1)

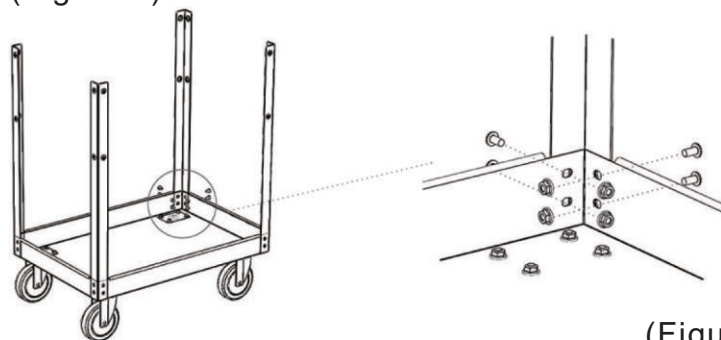

(Figura 2)

Usando parafusos de transporte, e Hex Nust, prenda a moldura de canto a cada um dos quatro cantos da prateleira inferior. (Figura 2)

NOTA: Preste muita atenção à direcção de montagem das armações dos cantos. É possível instalá-las de cabeça para baixo. Isto teria de ser corrigido antes que a montagem pudesse ser comoleted. o primeiro buraco no topo/cima-medida 1,38" a partir do fim. O primeiro furo na parte de baixo mede 1,02" a partir da sua extremidade. (Figura 2)

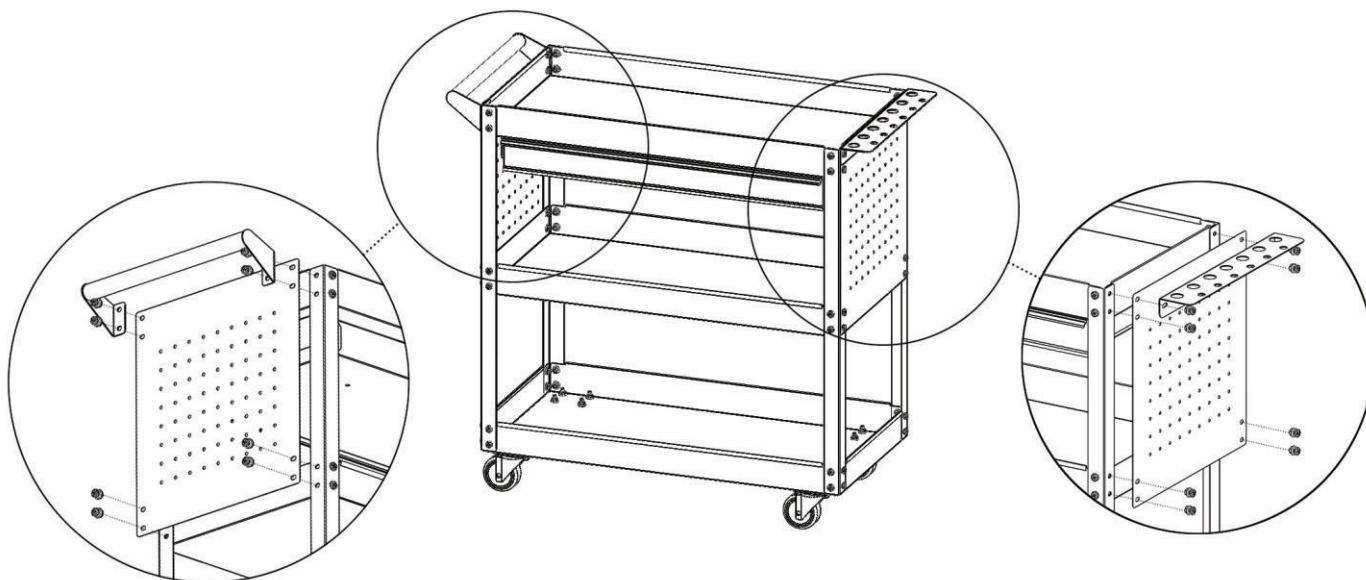

Befestigen Sie die Lenkrolle mit vier Schlossschrauben, vier Unterlegscheiben für die Lenkrolle und vier Sechskantmuttern für die Lenkrolle an der nächsten Ecke des unteren Regals und folgen Sie denselben Anweisungen für die letzte Lenkrolle (Abbildung 1).

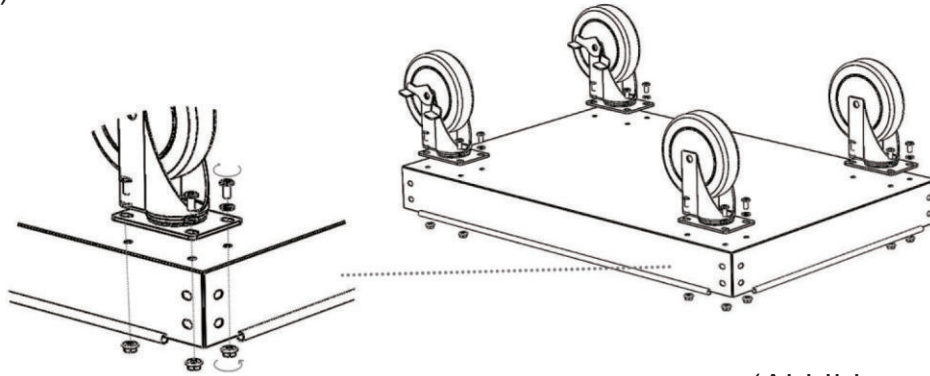

(Abbildung 1)

Hinweis: An jeder Ecke der schmalen Seiten des unteren Regals sollten "gleiche" Rollen angebracht werden: zwei Lenkrollen (frei rollend) und zwei Lenkrollen mit Bremse (Abbildung 1).

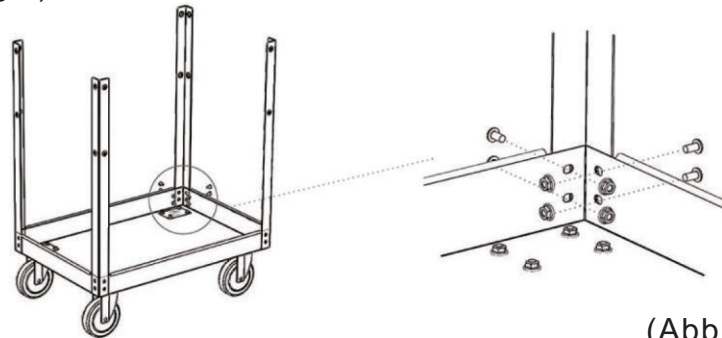

(Abbildung 2)

Befestigen Sie die Eckrahmen mit Schlossschrauben und Sechskantmuttern an jeder der vier Ecken des unteren Regals (Abbildung 2).

HINWEIS: Achten Sie genau auf die Montagerichtung der Eckrahmen, es ist möglich, dass sie verkehrt herum eingebaut werden. Das erste Loch in der oberen/oberen Seite misst 1,38" vom Ende. Das erste Loch auf der Unterseite/unten misst 1,02" von seinem Ende aus (Abbildung 2).

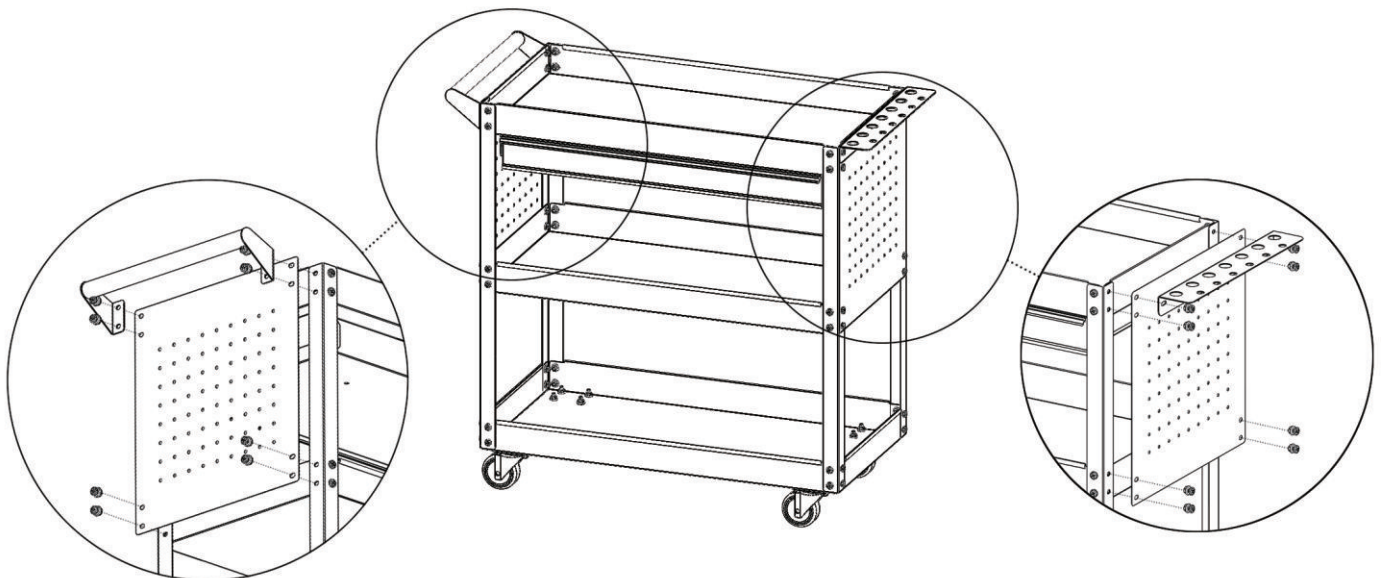

Utilizzando quattro bulloni a carrello, quattro rondelle per la rotella e quattro dadi esagonali per la rotella, fissare la rotella girevole all'angolo successivo del ripiano inferiore e, infine, seguire le stesse indicazioni per l'ultima rotella girevole (Figura 1).

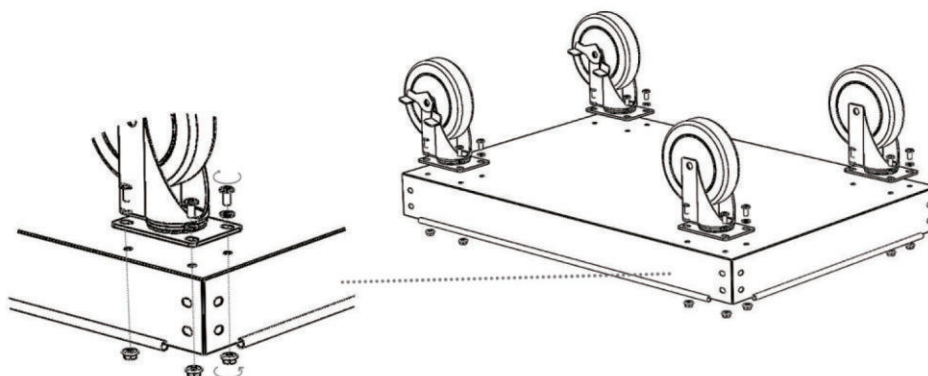

(Figura 1)

Nota: le rotelle "tipo" devono essere fissate a ciascun angolo dei lati stretti del ripiano inferiore. Sono disponibili due rotelle girevoli (a rotazione libera) e due rotelle girevoli con freno (Figura 1).

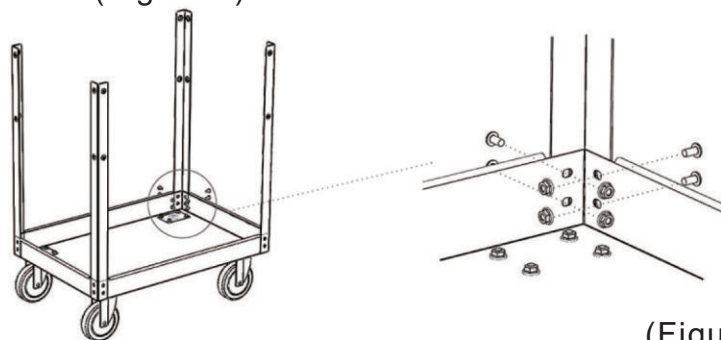

(Figura 2)

Utilizzando bulloni a carrello e brugole, fissare i telai d'angolo a ciascuno dei quattro angoli del ripiano inferiore (Figura 2).

NOTA: prestare molta attenzione alla direzione di montaggio dei telai d'angolo. È possibile che vengano installati al contrario. Il primo foro nella parte superiore/superiore misura 1,38" dall'estremità. Il primo foro nel lato inferiore misura 1,02" dall'estremità (Figura 2).

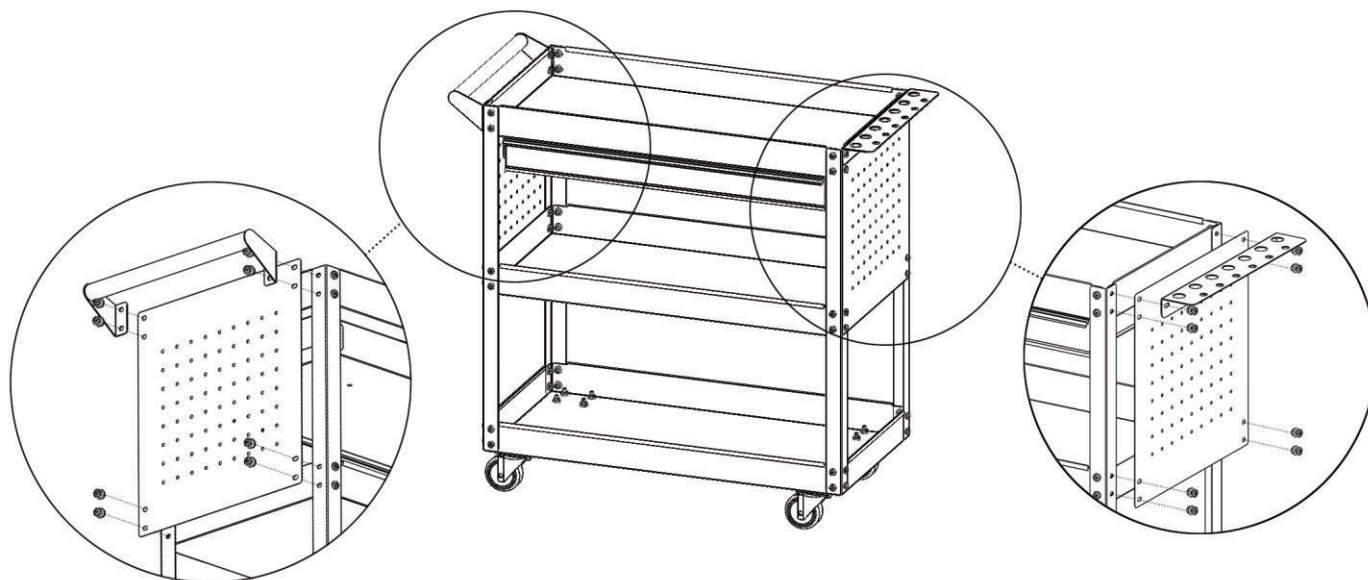

Za pomocą czterech śrub dwustronnych, czterech podkładek do kółek i czterech nakrętek sześciokątnych do kółek przymocuj kółko obrotowe do następnego rogu dolnej półki, a na koniec postępuj zgodnie z tymi samymi instrukcjami dla ostatniego kółka obrotowego. (Rys. 1)

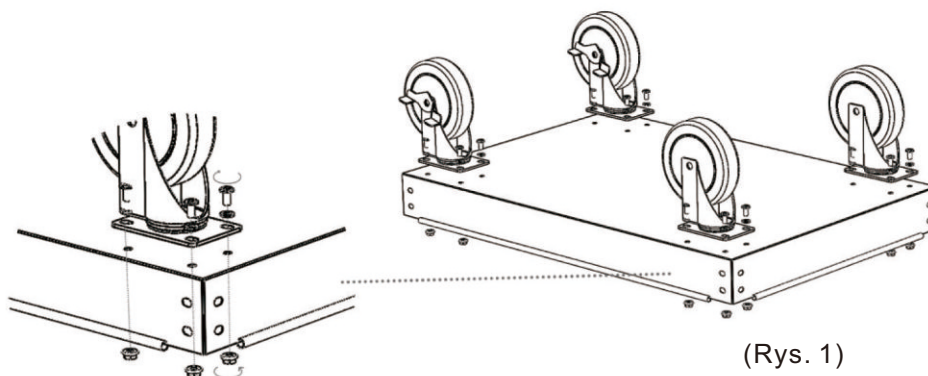

(Rys. 1)

Uwaga: Kółka typu „Like” należy zamocować w każdym rogu wąskich boków dolnej półki. Są dwa kółka obrotowe (swobodnie obracające się) i dwa kółka obrotowe z hamulcem (rys. 1).

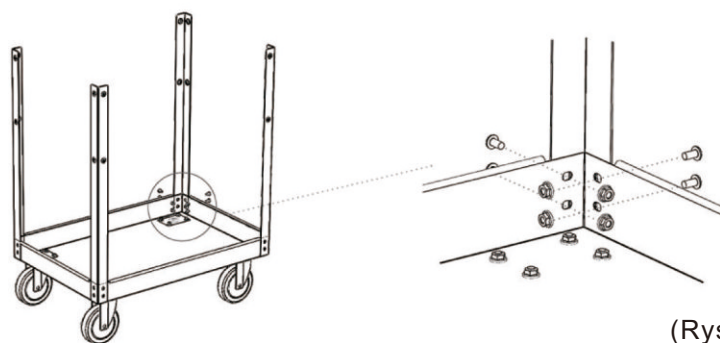

(Rys. 2)

Za pomocą śrub dwustronnych i nakrętek sześciokątnych przymocuj ramy narożne do każdego z czterech rogów dolnej półki. (Rys. 2)

UWAGA: Należy zwrócić szczególną uwagę na kierunek montażu ram narożnych. Istnieje możliwość zamontowania ich do góry nogami. Należy to skorygować przed zakończeniem montażu. Pierwszy otwór w górnej/górnej części znajduje się w odległości 1,38 cala od końca. Pierwszy otwór w dolnej/dolnej części znajduje się w odległości 1,02 cala od końca. (Rys. 2)

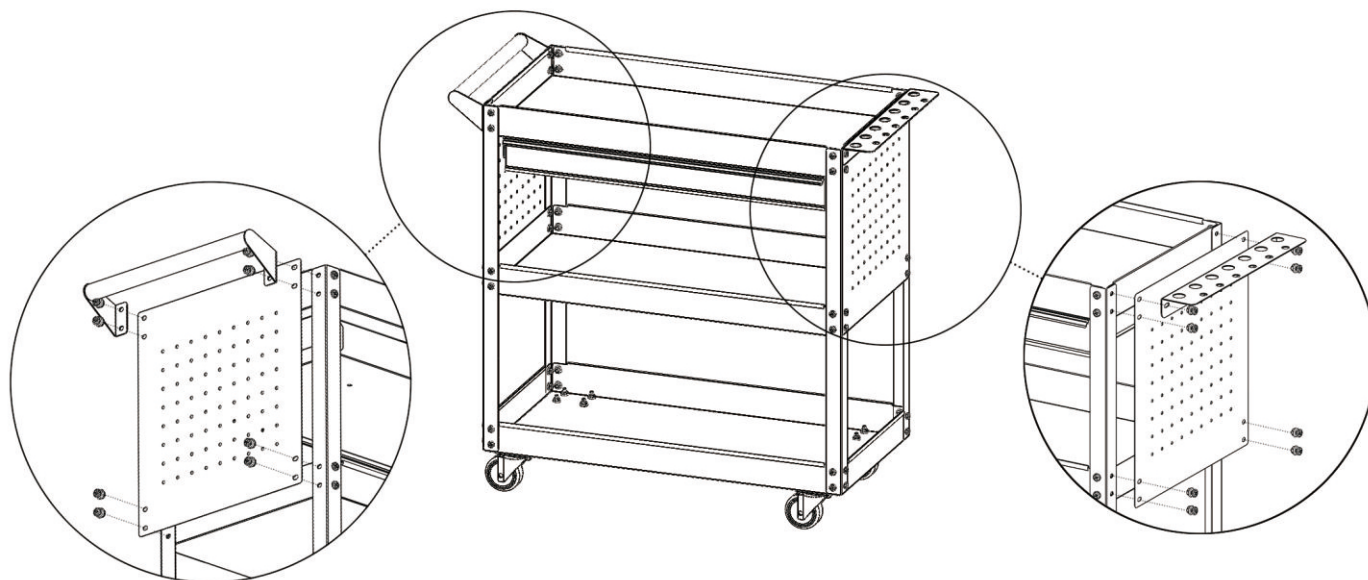

Folosind patru șuruburi cu cap bombat, patru șaibe pentru roțile și patru piulițe hexagonale pentru roțile, fixați roata pivotantă la colțul următor al raftului inferior și, în final, urmați aceleași instrucțiuni pentru ultima roată pivotantă. (Fig. 1)

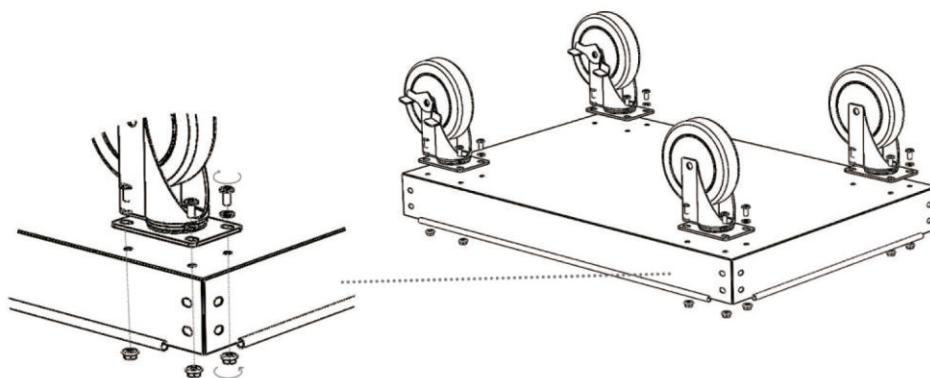

(Fig1)

Notă: Rolele „Like” trebuie fixate în fiecare colț al laturilor înguste ale raftului inferior. Există două role pivotante (cu rulare liberă) și două role pivotante cu frână. (Fig. 1)

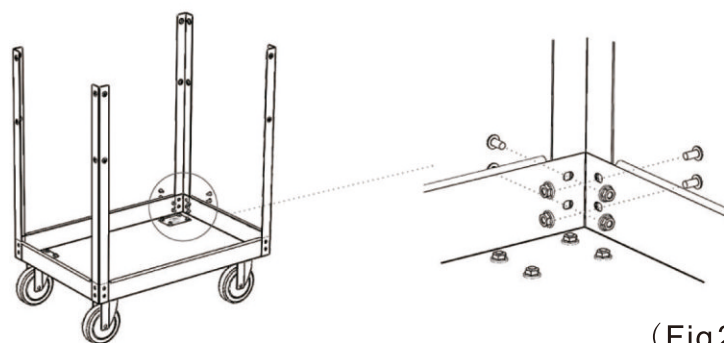

(Fig2)

Folosind șuruburi cu cap bombat și piulițe hexagonale, fixați cadrele de colț la fiecare dintre cele patru colțuri ale raftului inferior. (Fig. 2)

NOTĂ: Acordați o atenție deosebită direcției de asamblare a cadrelor de colț. Este posibil să le instalați cu susul în jos. Acest lucru trebuie corectat înainte de finalizarea asamblării. Primul orificiu din partea superioară/sus se află la 1,38„ de capăt. Primul orificiu din partea inferioară/jos se află la 1,02” de capăt. (Fig 2)

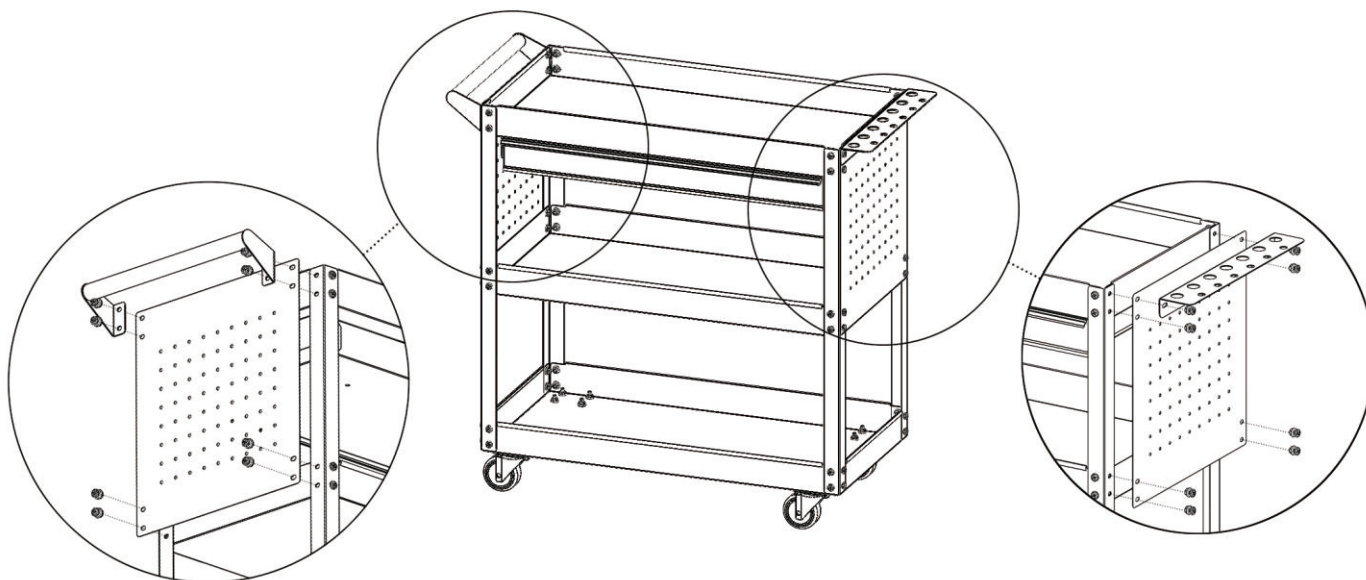

If you have any questions, please contact our customer care center, Our contact details are below:

US

 001-877-644-9366

 customerservice@aosom.com

Imported by Aosom LLC
7777 Center Ave. Suite 430
Huntington Beach, CA 92647-9998 USA
MADE IN CHINA

Si tiene alguna pregunta, comuníquese con nuestro Centro de Atención al Cliente, Nuestros datos de contacto son los siguientes:

ES

 0034-931294512

 atencioncliente@aosom.es

IMPORTADOR/Fabricante/REP:
SPANISH AOSOM, S.L.
C/ROC GROS,Nº15.08550, ELS HOSTALETES DE
BALENYÀ, SPAIN.
B66295775
HECHO EN CHINA

Se tiver alguma dúvida, por favor contacte o nosso Centro de Atendimento ao Cliente, Os nossos dados de contacto são os seguintes:

 0034-931294512

 info@aosom.pt.

IMPORTADOR/Fabricante/REP:
SPANISH AOSOM, S.L.
C.ROC GROS N.15, 08550. ELS HOSTALETES DE
BALENYÀ
FEITO NA CHINA

If you have any questions, please contact our customer care center, Our contact details are below:

CA

 416-792-6088

 customerservice@aosom.ca

Imported by Aosom Canada Inc.
7270 Woodbine Avenue, Unit 307, Markham,
Ontario Canada L3R 4B9
MADE IN CHINA

Si vous avez la moindre question, veuillez contacter notre centre d'assistance à la clientèle, Nos coordonnées sont les suivantes:

 416-792-6088

 customerservice@aosom.ca

Importé par Aosom Canada Inc.
7270 Woodbine Avenue, unité 307,
Markham, Ontario Canada L3R 4B9
FABRIQUÉ EN CHINE

In caso di dubbio, si prega di contattare il nostro centro assistenza clienti, I nostri dettagli di contatto sono di seguito:

IT

 0039-0249471447

 clienti@aosom.it

IMPORTATO DA/Produttore/REP:
AOSOM Italy srl
Centro Direzionale Milanofiori
Strada 1 Palazzo F1
20057 Assago (MI)
P.I.: 08567220960
FATTO IN CINA

If you have any questions, please contact our customer care center, Our contact details are below:

UK

 0044-800-240-4004

 enquiries@mhstar.co.uk

IMPORTER ADDRESS:
MH STAR UK Ltd
1 Northampton Cross Logistics Park
Northampton Cross Road
Northampton
NN4 9FH
MADE IN CHINA

Wenn Sie Fragen haben, wenden Sie sich bitte an unser Kundendienstzentrum, Unsere Kontaktdaten stehen unten:

DE

 0049-0(40)-87408465

 service@aosom.de

ADRESSE DES IMPORTEURE/Hersteller/REP:
MH Handel GmbH
Wendenstraße 309
D-20537 Hamburg
Germany
IN CHINA HERGESTELLT

Si vous avez la moindre question, veuillez contacter notre centre d'assistance à la clientèle, Nos coordonnées sont les suivantes:

FR

 0033-1-84166106

 aosom@mhfrance.fr

Importé par/Fabricant/REP:
MH FRANCE
2 Rue Maurice Hartmann
92130 Issy Les Moulineaux
France
FABRIQUÉ EN CHINE



FR

**DONNEZ
OU
RECYCLEZ**



ASSOCIATION

OU



LIVRAISON

OU



DÉCHÈTERIE

Adresses sur quefairedemesdechets.fr