

SPORTNOW

IN221000258V02_UK_FR_ES_PT_DE_IT

A61-039V00_A61-040V00

EN

Basketball Backboard

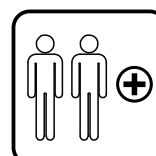
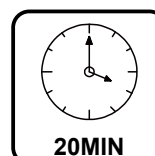
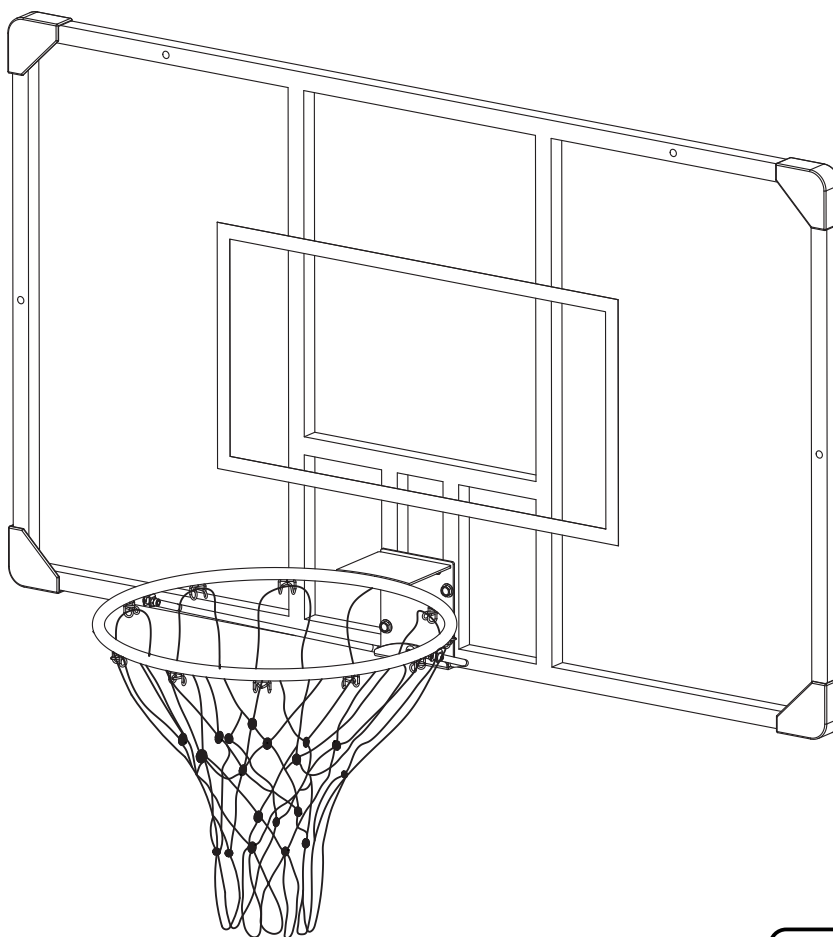

IMPORTANT, RETAIN FOR FUTURE REFERENCE: READ CAREFULLY

USER MANUAL

General Safety Instructions

- Two capable adults are required for this assembly.
- Read and understand the manual before assembling and using the unit.
- Failure to follow the instructions could result in injury or damage to the property.
- Select a safe place to install the backboard.
- Use extreme caution when using ladder.
- Make sure the backboard is firmly installed.
- Do not hang from the backboard and rim.
- Remove all contents from box and make sure this matches the parts list.
- Do not return the product in store, please contact customer service.

Maintenance

1. Regularly check if the backboard is firmly attached on the wall or mounting bracket. It is required to tighten if the screws are loose.
2. Check your basketball system frequently for loose hardware, excessive wear; and signs of corrosion.

For safety reasons, and to prolong the life of your basketball system, you must take the following preventative measures.

(1) Check all nuts and bolts. If any are loose, tighten them.

(2) Check all parts for excessive wear and tear. If necessary replace any parts that have been worn or damaged through usage. Contact our Customer Service Department for replacement parts.

Note: DO NOT HANG FROM RIM

Part List

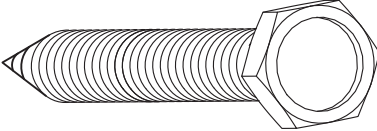
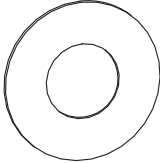
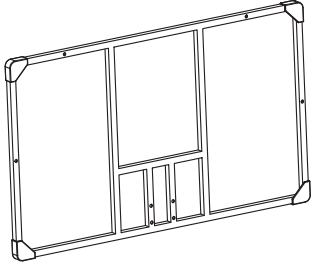
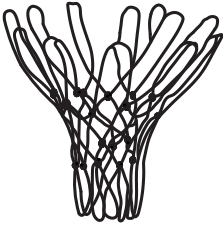
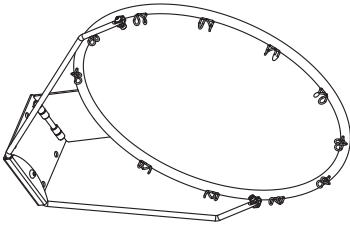
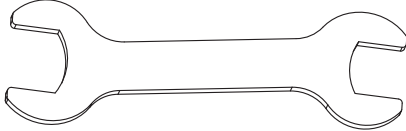
	DESCRIPTION	PART IMAGE	Qty
1	Wall plug		8
2	Bolts		8
3	Washer		8
4	Backboard		1
5	Net		1
6	Rim		1
7	Tools		1

Assembly

Step 1

Find a suitable wall/board for ball-shooting.

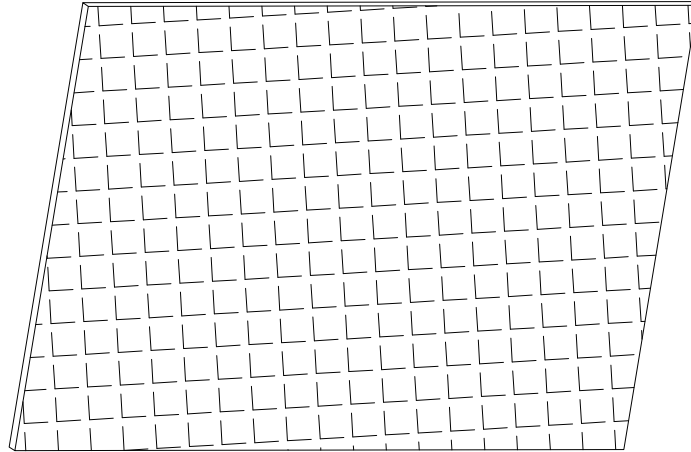

Step 2

Place the backboard(#4) on desired areas to navigate & prepare for drilling.

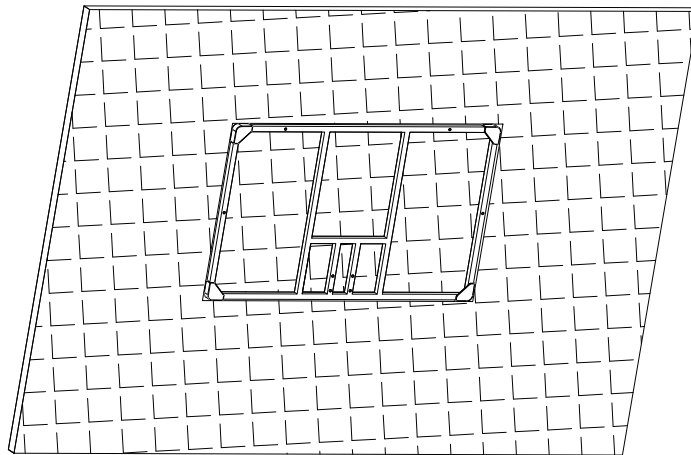

Step 3

Drill the wall/board according to the location of the backboard, and stuff the Wall plug (#1 * 8) into the holes.

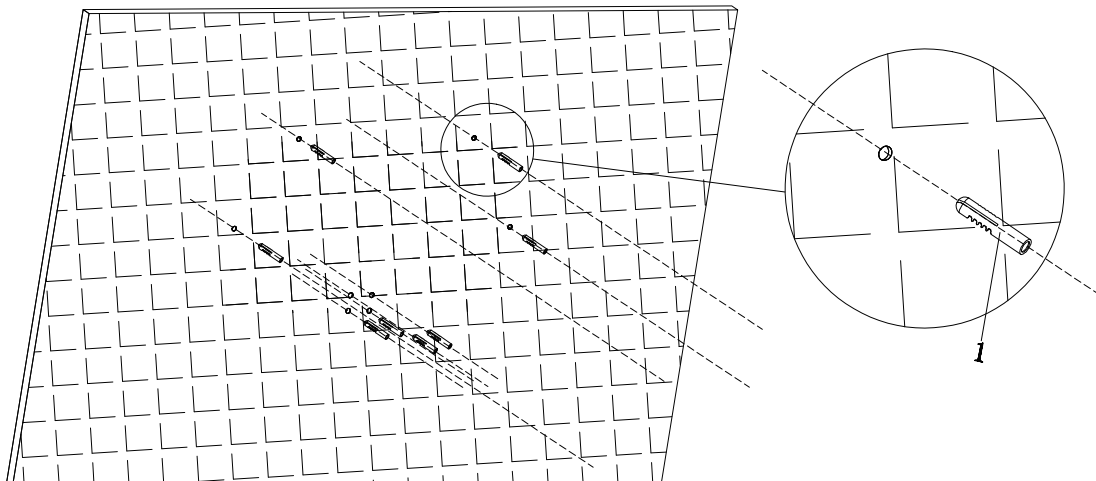

Step 4

Locking the basketball hoop.

- Align the backboard (#4) with the corresponding holes, and put in 4 sets of Bolts (#2) and washer (#3). Tighten the screws.
- Align the Rim (#6) with 4 holes located at the bottom of the backboard, and put in 4 sets of Bolts (#2) and washer (#3). Tighten the screws.
- Hang the basketball net (#5).
- Assembly Complete.

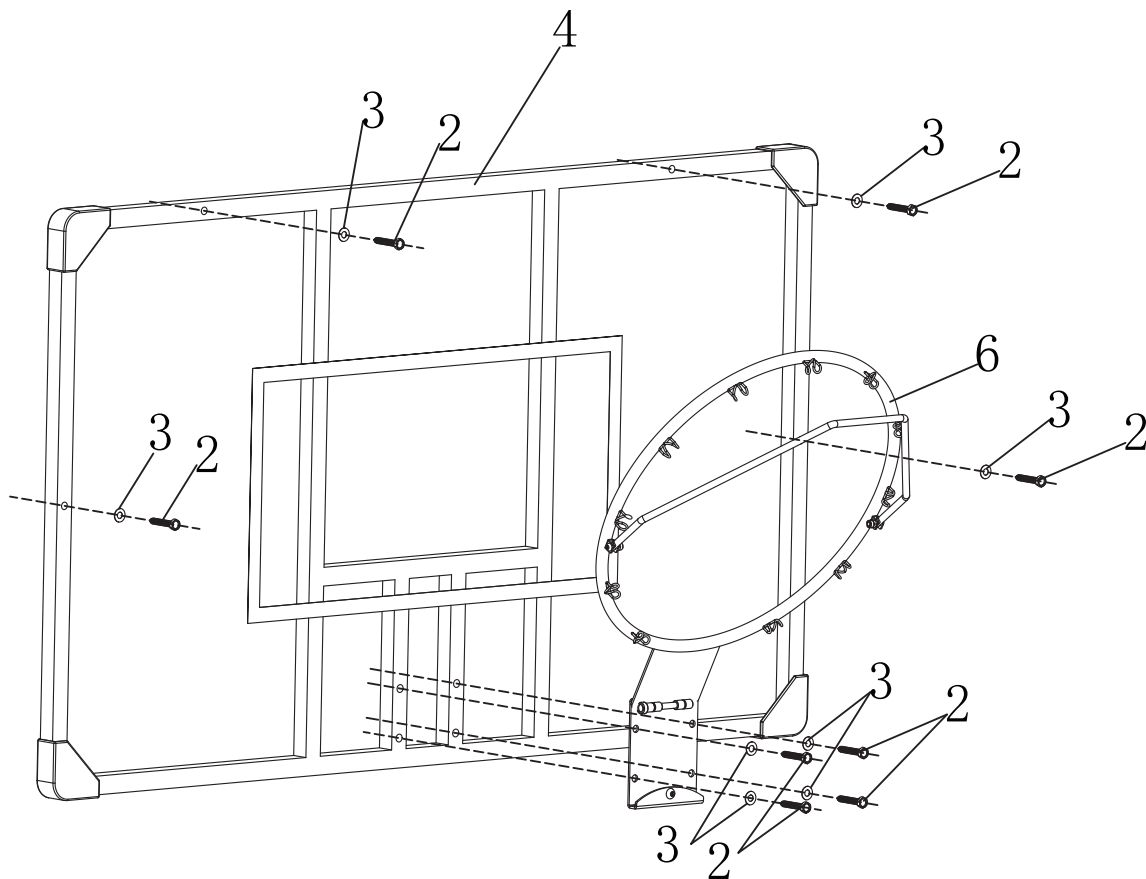

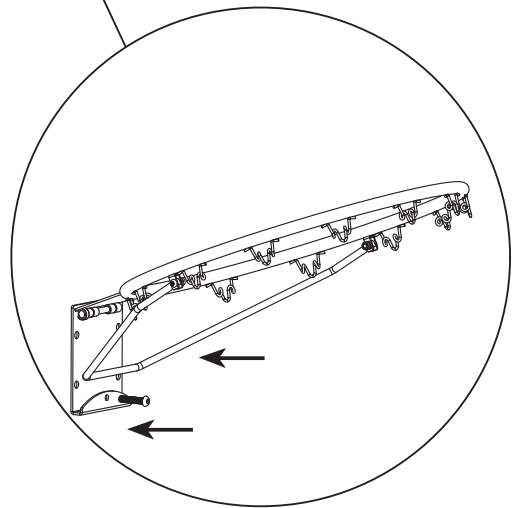
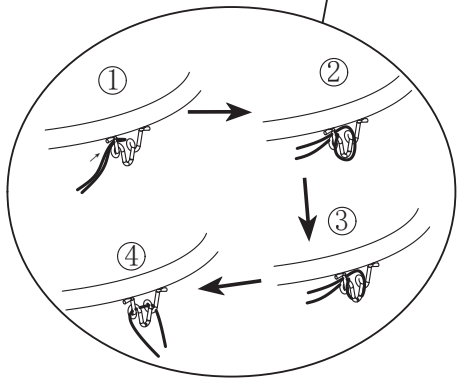
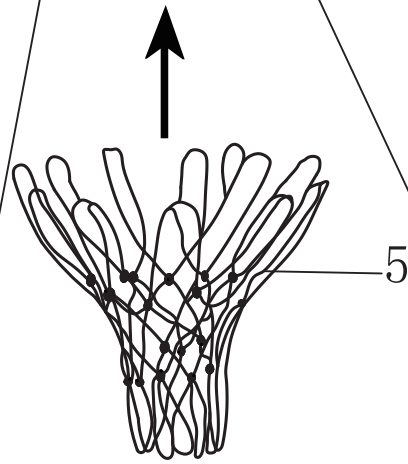
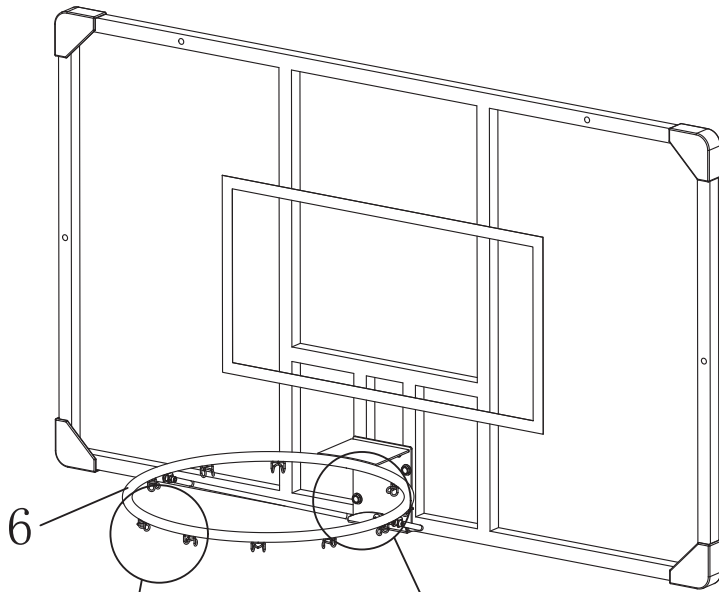

SPORTNOW

IN221000258V02_UK_FR_ES_PT_DE_IT

A61-039V00_A61-040V00

FR

Panneau de basketball

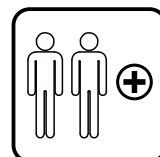
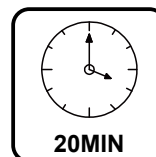
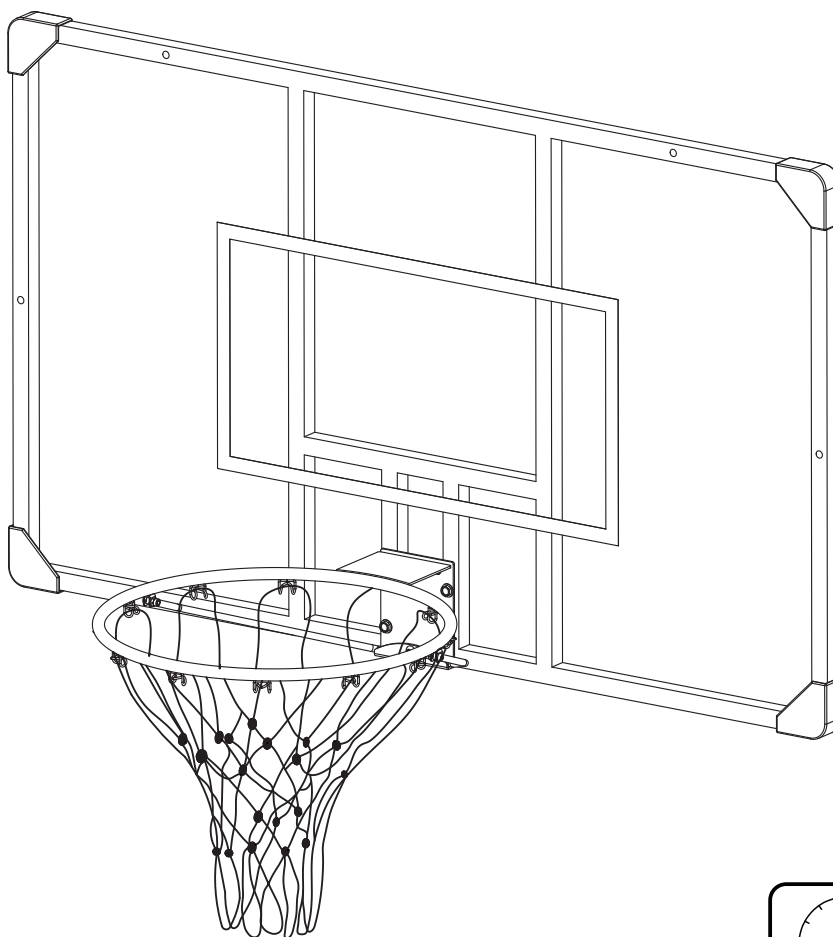

**IMPORTANT, CONSERVEZ LES INSTRUCTIONS
POUR RÉFÉRENCE ULTÉRIEURE : LISEZ ATTENTIVEMENT**

Manuel d'Instructions

Consignes de sécurité générales

- Deux adultes aptes sont requis pour cet assemblage.
- Lisez attentivement le manuel avant d'assembler et d'utiliser l'appareil.
- Le non-respect des instructions pourrait entraîner des blessures ou des dommages au matériel.
- Sélectionnez un endroit sûr pour installer le panneau arrière.
- Soyez extrêmement prudent lorsque vous utilisez une échelle.
- Assurez-vous que le panneau arrière est bien installé.
- Ne vous suspendez pas au panneau arrière et au cerceau.
- Retirez tout le contenu de la boîte et veillez à ce qu'il corresponde à la liste des pièces.
- Ne retournez pas le produit en magasin, veuillez contacter le service après-vente.

Entretien

1. Vérifiez régulièrement si le panneau arrière est fermement fixé au mur ou au support de montage. Il est nécessaire de serrer les vis s'ils sont desserrés.
2. Vérifiez fréquemment que votre système de basket-ball ne présente pas de pièces desserrées, d'usure excessive ou de signes de corrosion.

Pour des raisons de sécurité, et pour prolonger la durée de vie de votre système de basketball, vous devez prendre les mesures préventives suivantes.

- (1) Vérifiez tous les écrous et boulons. Si certains sont desserrés, serrez-les.
- (2) Vérifiez toutes les pièces pour détecter une usure excessive. Si nécessaire, remplacez toutes les pièces usées ou endommagées par l'utilisation. Contactez notre service clientèle pour obtenir des pièces de rechange.

Note : NE PAS SUSPENDRE AU CERCEAU

Liste des pièces

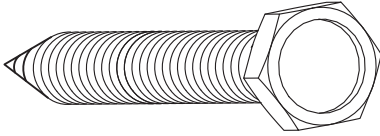
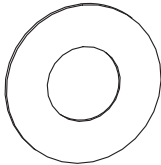
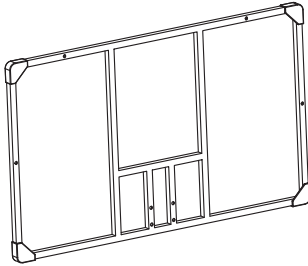
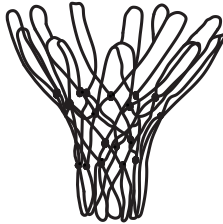
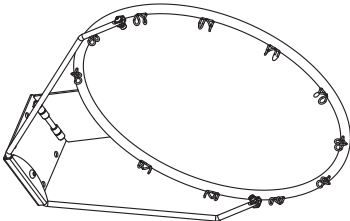
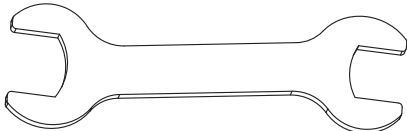
	DESCRIPTION	FIGURE DE LA PIÈCE	QTE
1	Prise		8
2	Boulon		8
3	Rondelle		8
4	Panneau		1
5	Filet		1
6	Cerceau		1
7	Outil		1

Assemblage

Étape 1

Trouvez un mur / tableau approprié pour le tir de balle.

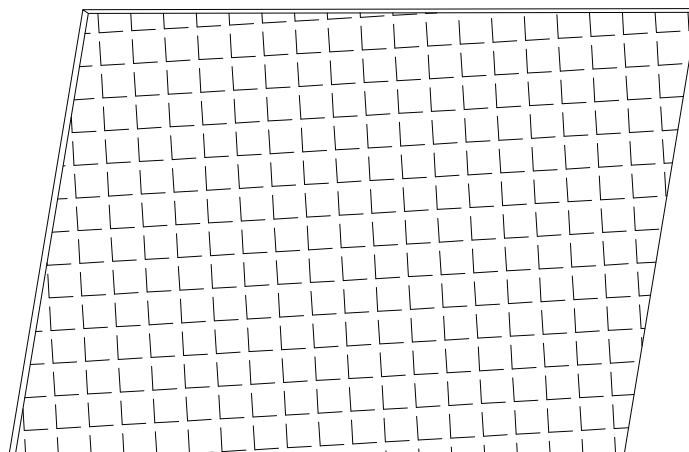

Étape 2

Placez le panneau arrière (# 4) sur les zones souhaitées pour naviguer et préparer le forage.

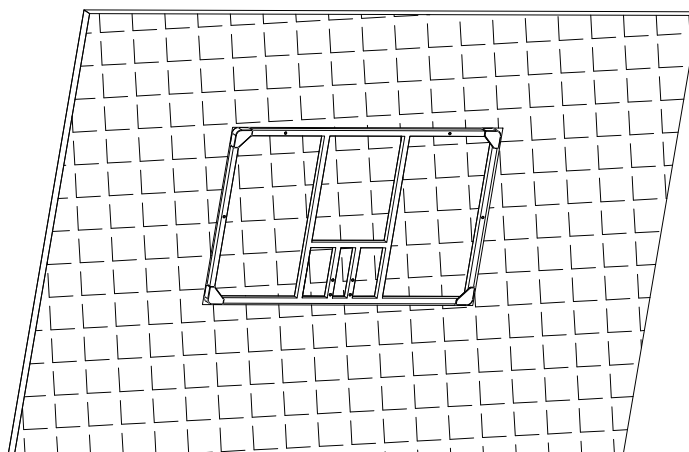

Étape 3

Percez le mur / planche en fonction de l'emplacement du panneau arrière et fourrez la prise murale (# 1 * 8) dans les trous.

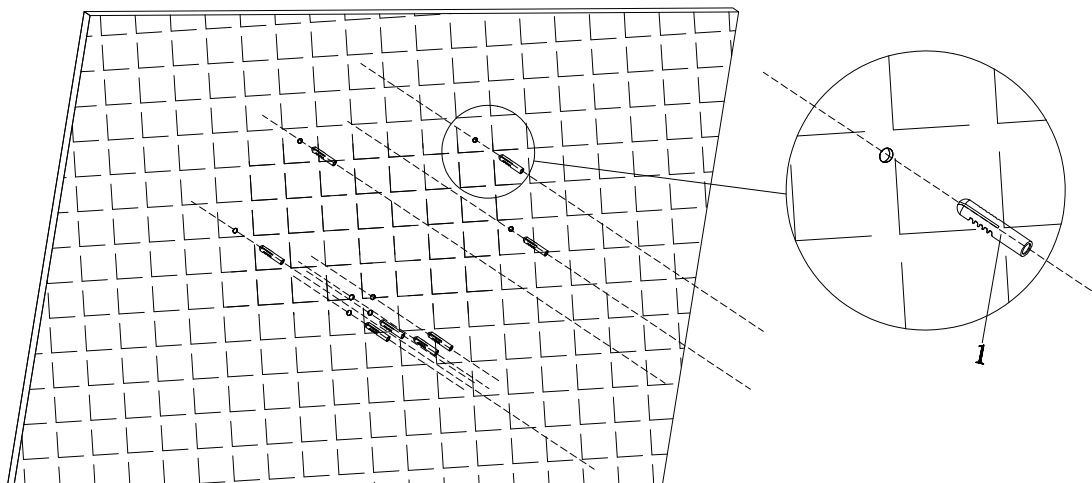

Étape 4

Verrouillez le panier de basketball.

- Alignez le panneau arrière (#4) avec les trous correspondants, et placez 4 jeux de boulons (#2) et une rondelle (#3). Serrez les vis.
- Alignez le cerceau (#6) avec 4 trous situés au bas du panneau arrière, et mettez en place 4 jeux de boulons (#2) et une rondelle (#3). Serrez les vis.
- Accrochez le filet de basket-ball (# 5).
- Assemblage terminé.

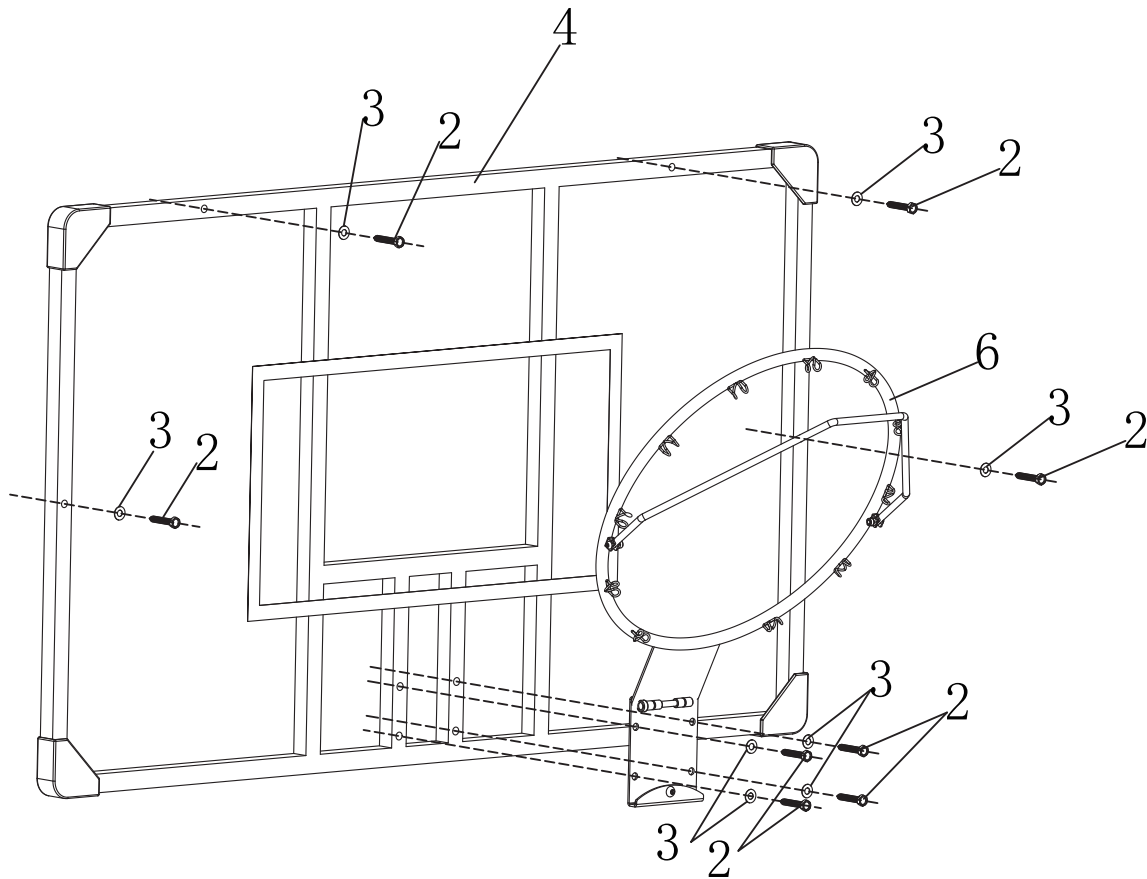

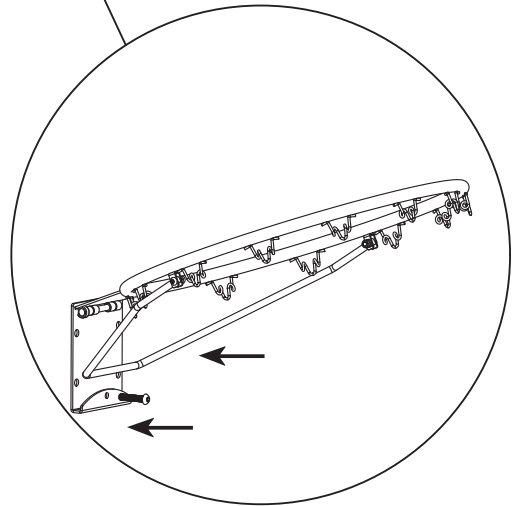
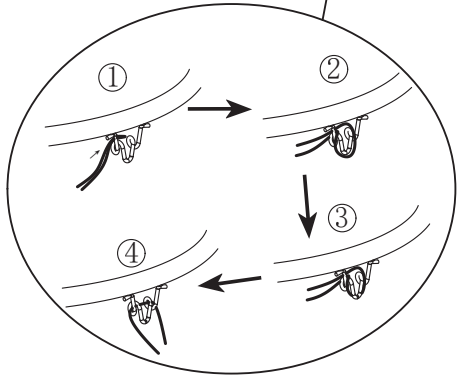
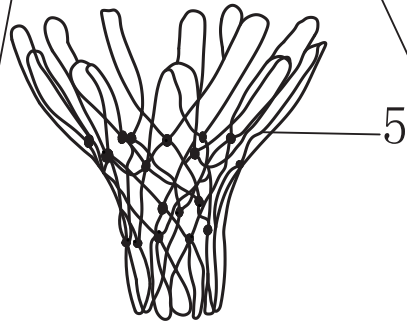
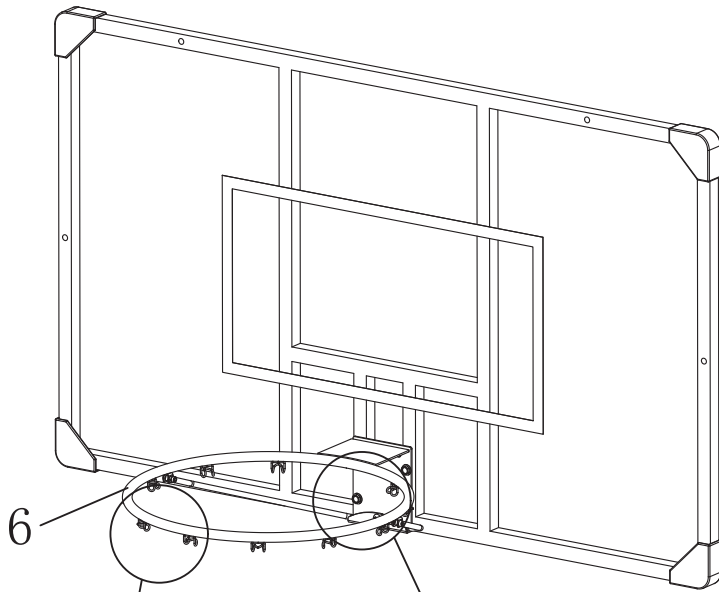

SPORTNOW

IN221000258V02_UK_FR_ES_PT_DE_IT

A61-039V00_A61-040V00

ES

Canasta de baloncesto

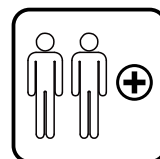
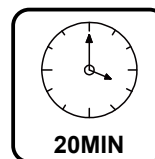
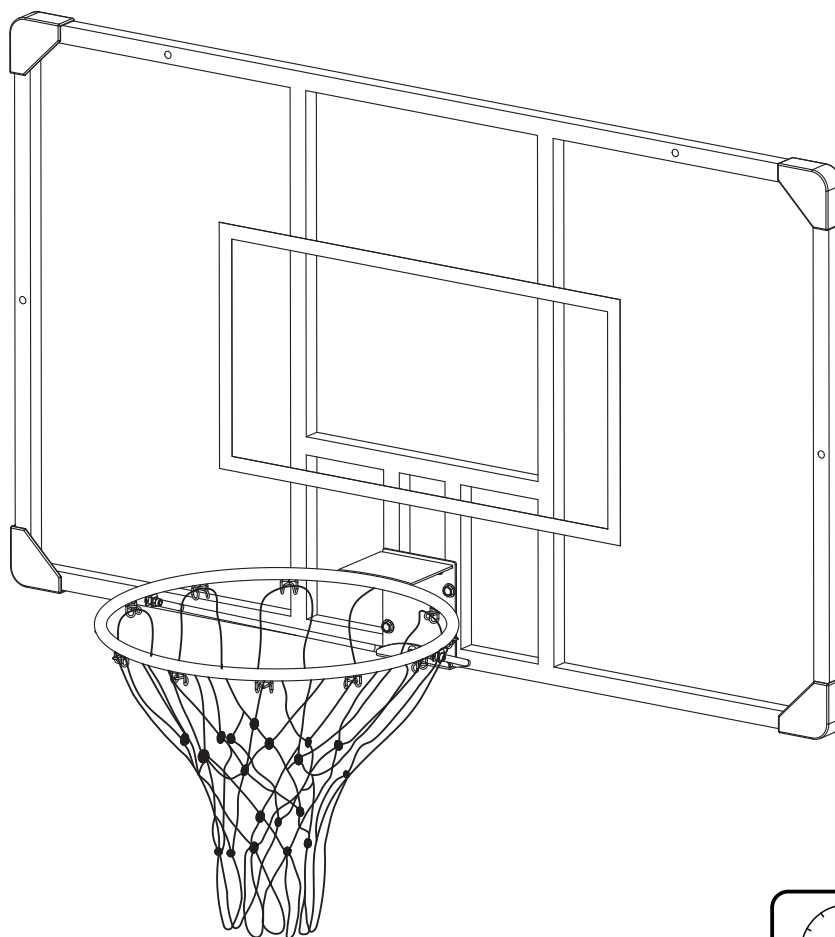

**IMPORTANTE - CONSERVE ESTA INFORMACIÓN
PARA SU CONSULTA POSTERIOR: LEER DETALLADAMENTE**

INSTRUCCIONES DE MONTAJE

Instrucciones generales de seguridad

- Para este montaje se requieren dos personas adultas capacitadas.
- Lea y comprenda el manual antes de montar y utilizar la unidad.
- El incumplimiento de las instrucciones puede provocar lesiones o daños materiales.
 - Seleccione un lugar seguro para instalar el tablero.
 - Vigile al utilizar la escalera.
 - Asegúrese de que el tablero esté firmemente instalado.
 - No se cuelgue del tablero ni del aro.
 - Saque todo el contenido de la caja y asegúrese de que coincide con la lista de piezas.
- No devuelva el producto sin antes ponerse en contacto con el servicio de atención al cliente.

Mantenimiento

1. Compruebe periódicamente si el tablero está firmemente sujeto a la pared o al soporte de montaje. Es necesario apretar si los tornillos están flojos.
2. Revise con frecuencia su canasta de baloncesto en busca de tornillería suelta, desgaste excesivo y signos de corrosión.

Por razones de seguridad, y para prolongar la vida de su canasta de baloncesto, debe tomar las siguientes medidas preventivas.

- (1) Compruebe todas las tuercas y tornillos. Si alguno está flojo, apriételo.
- (2) Compruebe que todas las piezas no estén excesivamente desgastadas . Si es necesario , sustituya las piezas desgastadas o dañadas por el uso. Póngase en contacto con nuestro Departamento de Atención al Cliente para solicitar piezas de repuesto.

Nota: NO COLGARSE DEL ARO

Lista de partes

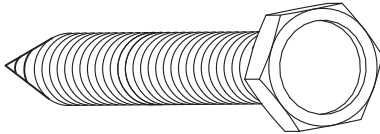
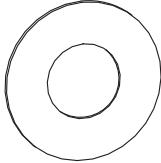
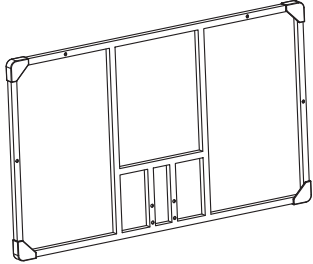
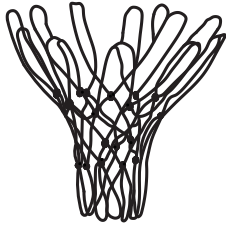
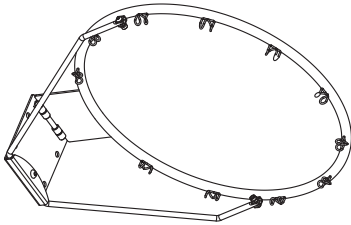
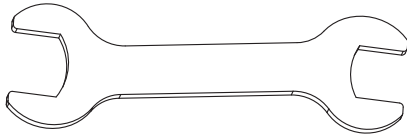
	DESCRIPCIÓN	IMAGEN	Cant.
1	Tacos		8
2	Tornillos		8
3	Arandela		8
4	Tablero trasero		1
5	Red		1
6	Aro		1
7	Llave		1

Montaje

Paso 1

Busca una pared/tablero adecuado para lanzar la pelota.

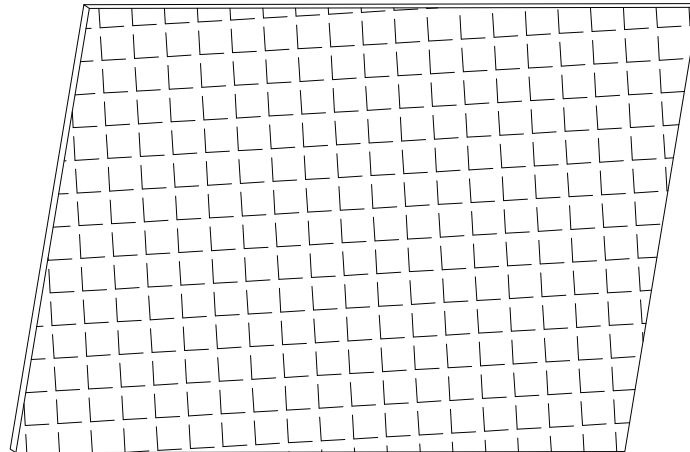

Paso 2

Coloque el tablero trasero (#4) en las áreas deseadas y preparar la perforación.

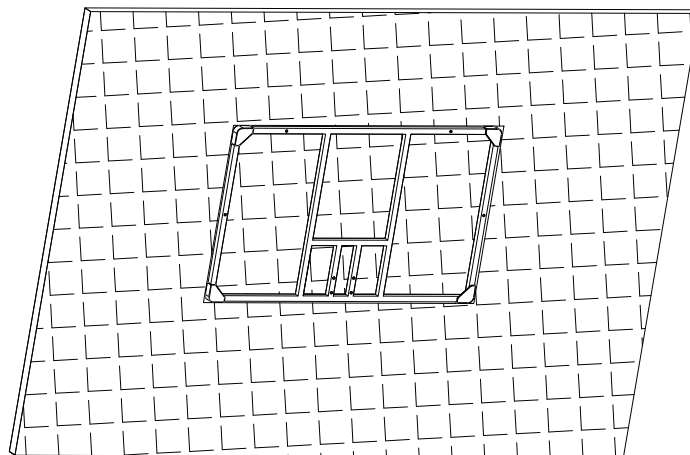

Paso 3

Taladre la pared/tablero de acuerdo con la ubicación del tablero y coloque los tacos de pared (#1 * 8) en los orificios.

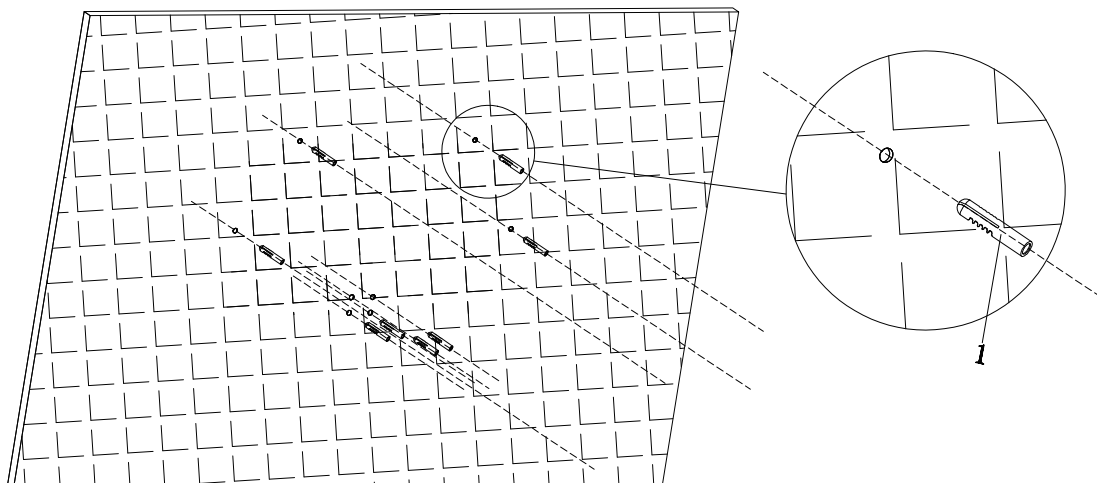

Paso 4

Bloqueo de la canasta de baloncesto.

- Alinee el tablero (#4) con los orificios correspondientes y coloque 4 juegos de tornillos (#2) y arandelas (#3). Apriete los tornillos.
- Alinee el aro (#6) con los 4 orificios situados en la parte inferior del tablero, y coloque 4 juegos de tornillos (#2) y arandelas (#3). Apriete los tornillos.
- Cuelgue la red en el aro (#5)
- Montaje terminado.

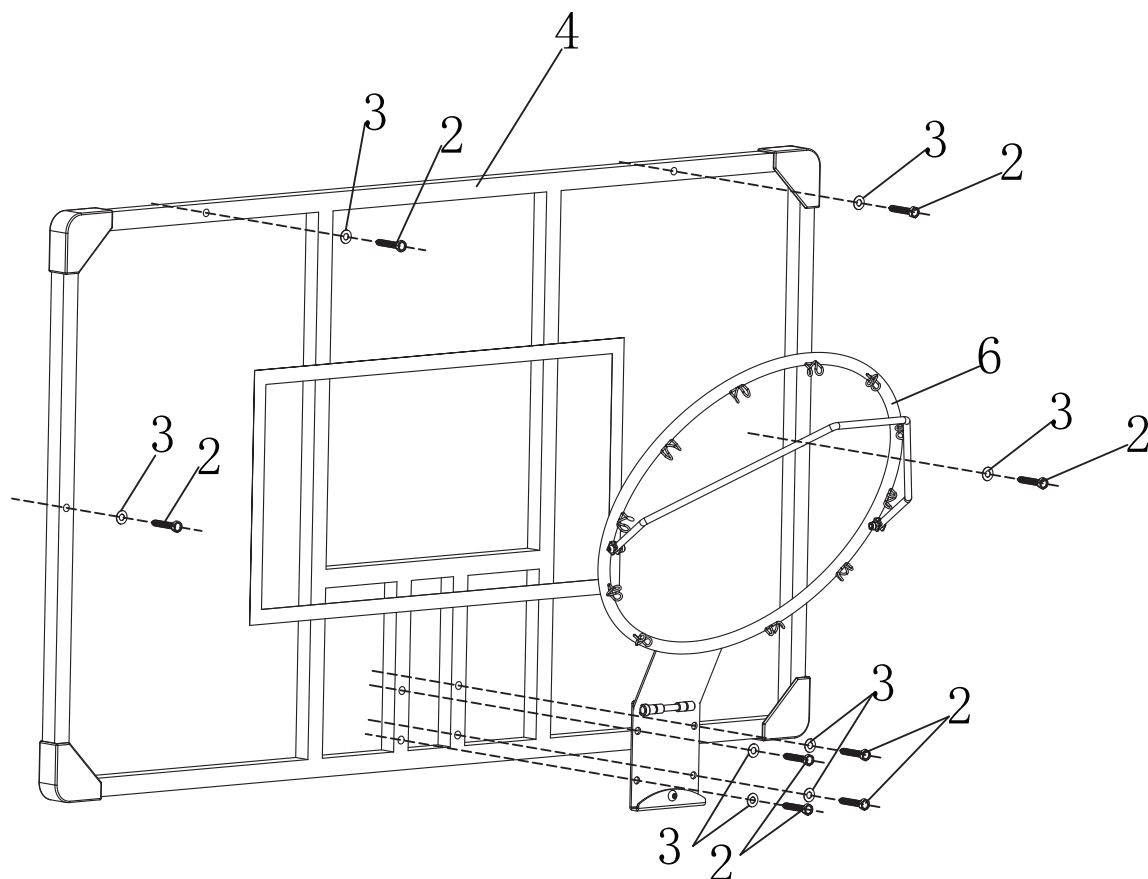

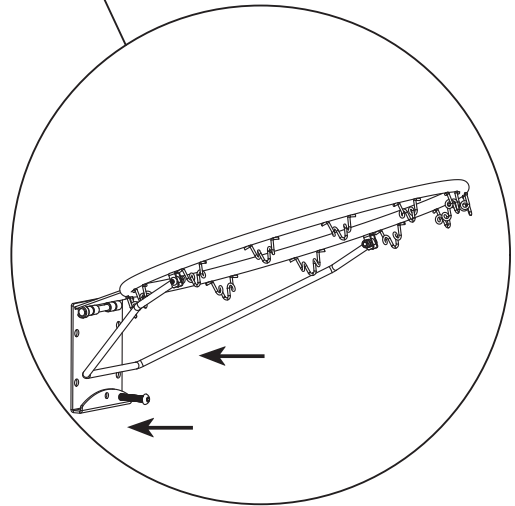
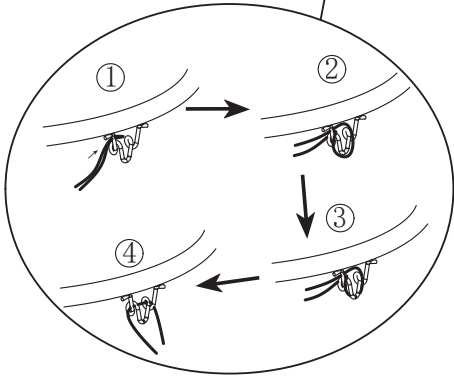
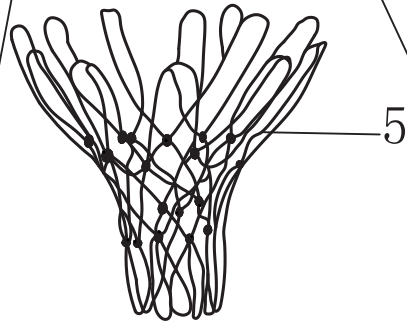
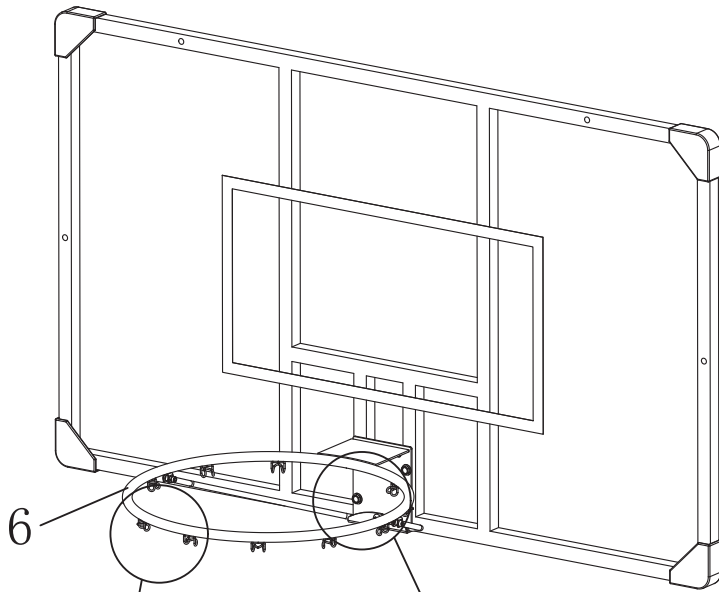

SPORTNOW

IN221000258V02_UK_FR_ES_PT_DE_IT

A61-039V00_A61-040V00

PT

Tabela de Basquetebol

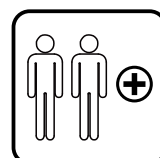
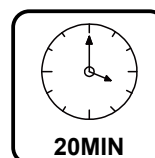
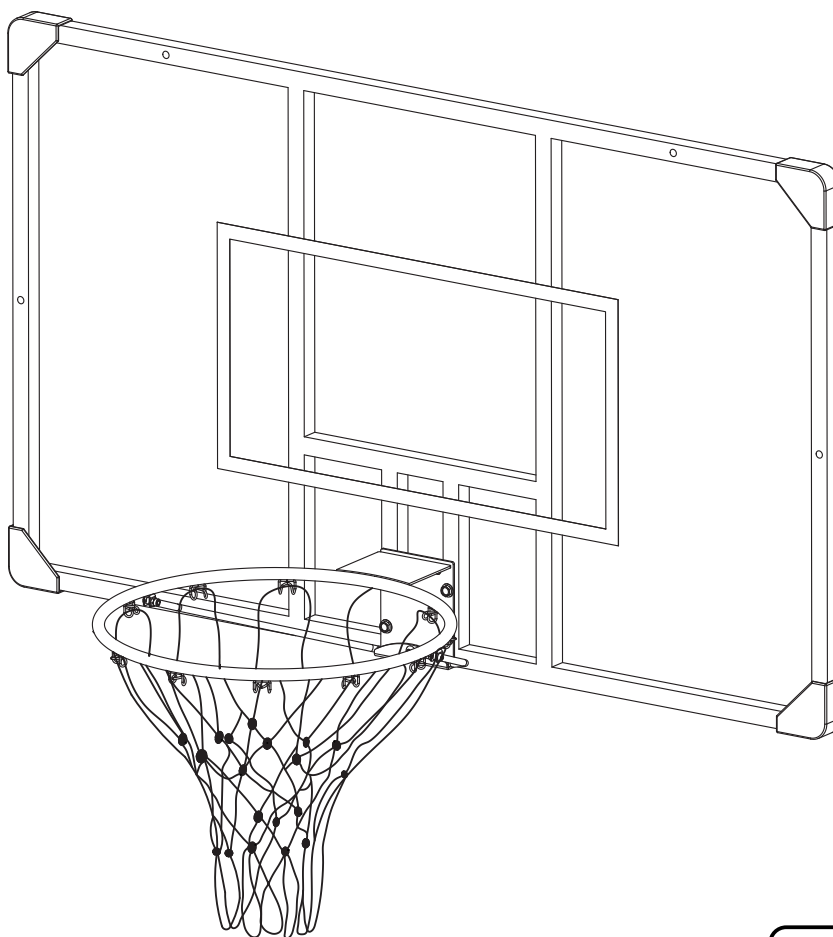

IMPORTANTE, GUARDE PARA FUTURAS REFERÊNCIAS: LEIA ATENTAMENTE

MANUAL DE INSTRUÇÕES

Instruções Gerais de Segurança

- São necessários dois adultos para esta realizar a montagem.
- Ler e compreender o manual antes de montar e utilizar a unidade.
- O não cumprimento das instruções pode resultar em ferimentos ou danos na unidade.
- Selecione um local seguro para instalar o painel traseiro.
- Tenha extremo cuidado ao utilizar a escada.
- Certifique-se de que o painel traseiro está firmemente instalado.
- Não pendurar-se no painel traseiro e no aro.
- Retirar todo o conteúdo da caixa e certificar-se de que este corresponde à lista de peças.
- Em caso de dúvidas, por favor contacte o serviço de atenção ao cliente.

Manutenção

1. Verificar regularmente se a placa traseira está firmemente fixada na parede ou no suporte de montagem. É necessário apertar se os parafusos estiverem soltos.
2. Verifique frequentemente se o sua tabela de basquetebol está solta, com desgaste excessivo ou sinais de corrosão.

Por razões de segurança, e para prolongar a vida útil da sua tabela de basquetebol, deve tomar as seguintes medidas preventivas.

- (1) Verificar todas as porcas e parafusos. Se alguns estiverem soltos, aperte-os.
- (2) Verificar todas as peças quanto a desgaste excessivo. Se necessário, substituir quaisquer peças que tenham sido desgastadas ou danificadas devido ao uso. Contacte o nosso Serviço de Atendimento ao Cliente para peças de substituição.

Nota: NÃO PENDURAR-SE NO ARO DA TABELA.

Lista de Partes

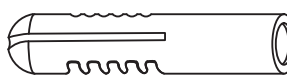
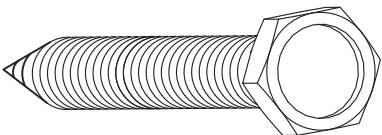
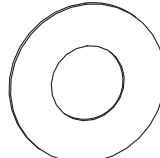
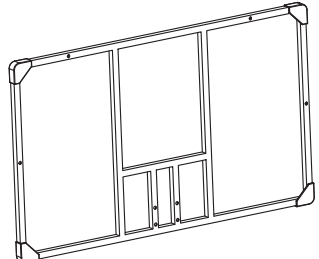
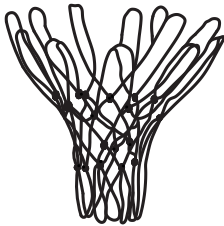
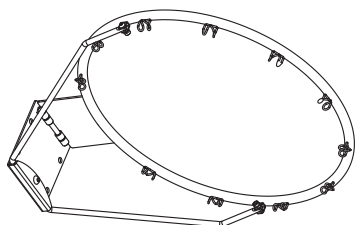
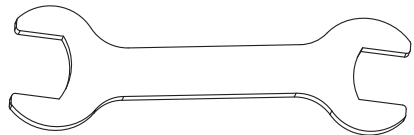
	DESCRIÇÃO	IMAGEM	QNT
1	Bucha de parede		8
2	Parafusos		8
3	Arruela		8
4	Tabela		1
5	Cesta		1
6	Aro		1
7	Ferramentas		1

Montagem

Passo 1

Encontrar uma parede/placa adequada para realizar a montagem da tabela de basquetebol.

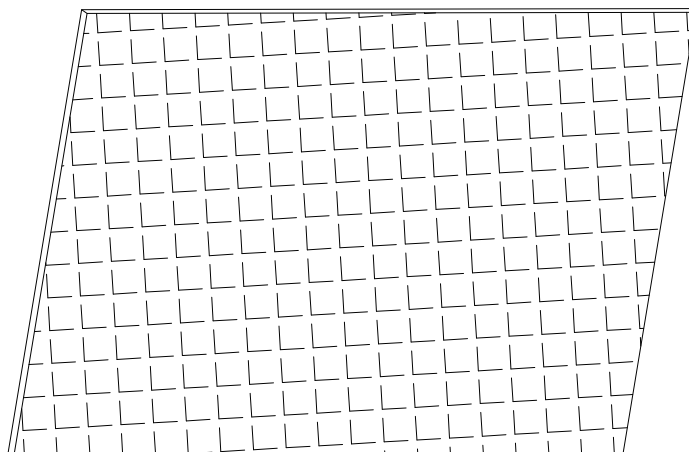

Passo 2

Colocar o a tabela (#4) na área desejada para e preparar-se para a perfuração.

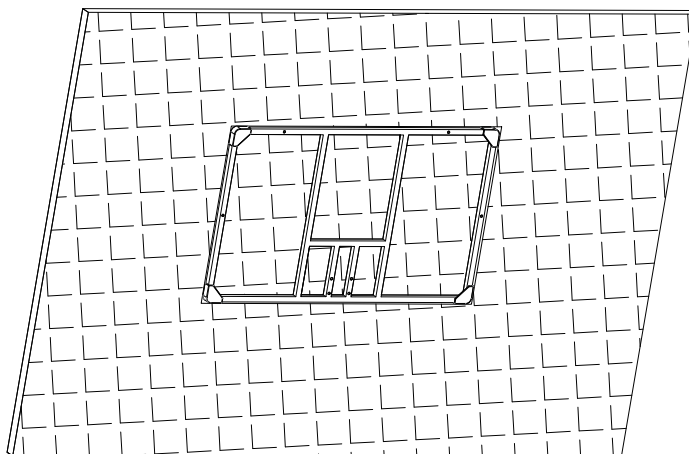

Passo 3

Perfurar a parede/placa de acordo com a localização da tabela, e colocar a bucha na parede (#1*8) nos orifícios.

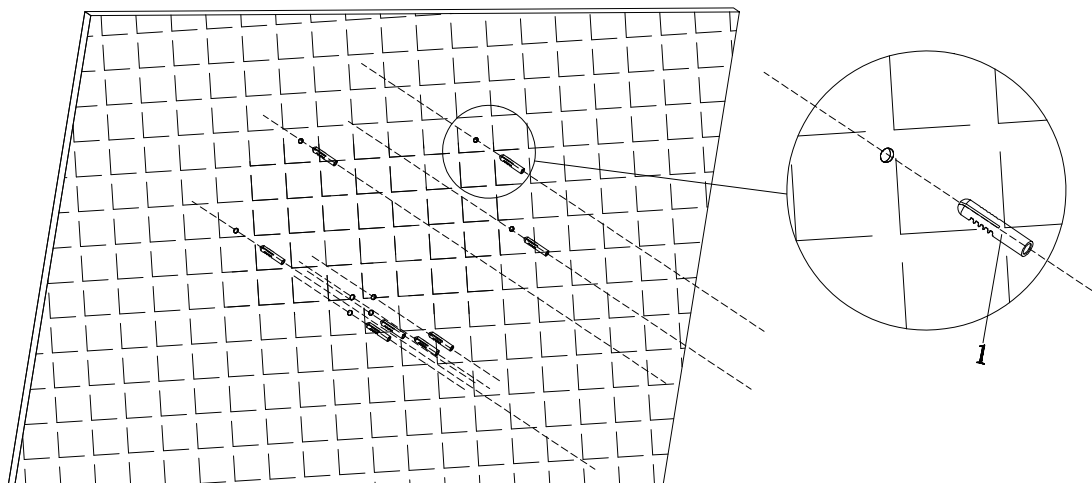

Passo 4

Colocar o aro de basquetebol.

- Alinhar o tabela (#4) com as respectivas buchas, e colocar os 4 conjuntos de parafusos (#2) e arruela (#3). Apertar os parafusos.
- Alinhar a aro (#6) com as 4 buchas localizadas na parte inferior da tabela, e colocar os 4 conjuntos de parafusos (#2) e arruela (#3). Apertar os parafusos.
- Pendurar a cesta de basquetebol (#5).
- Montagem completa.

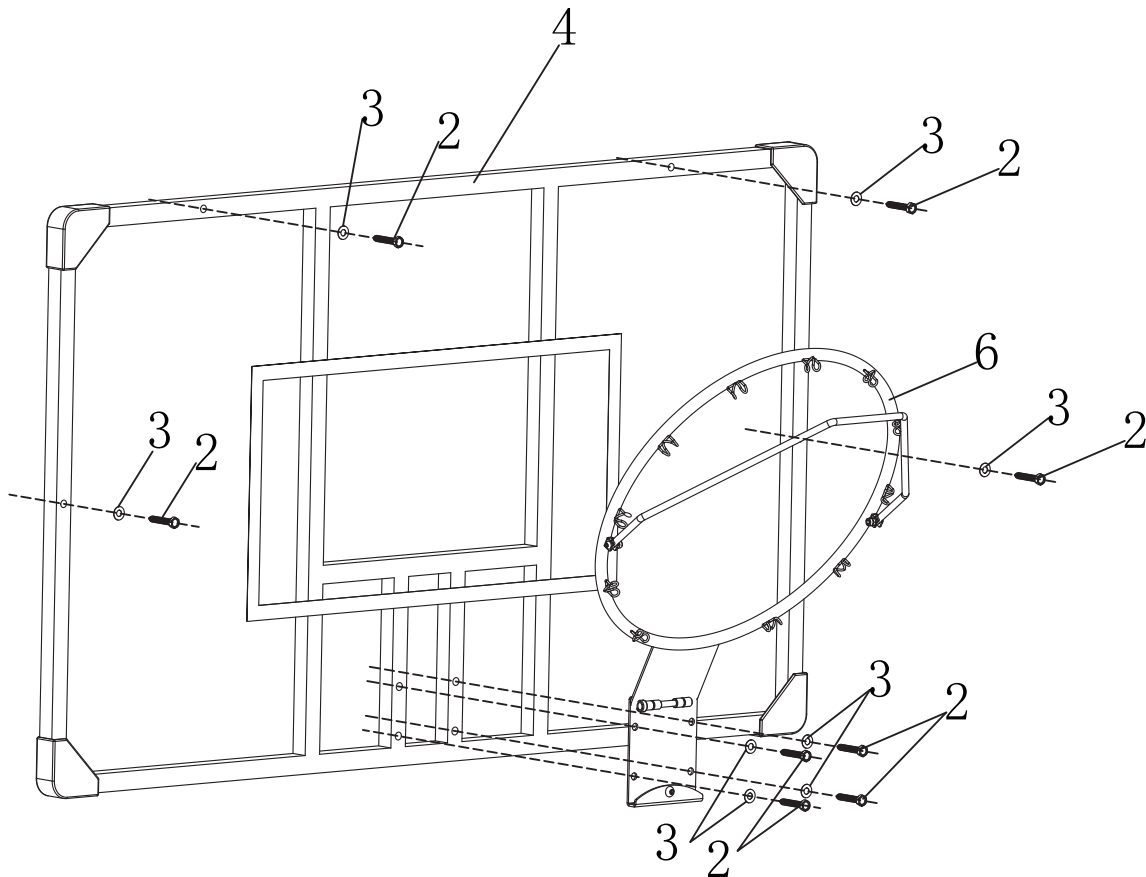

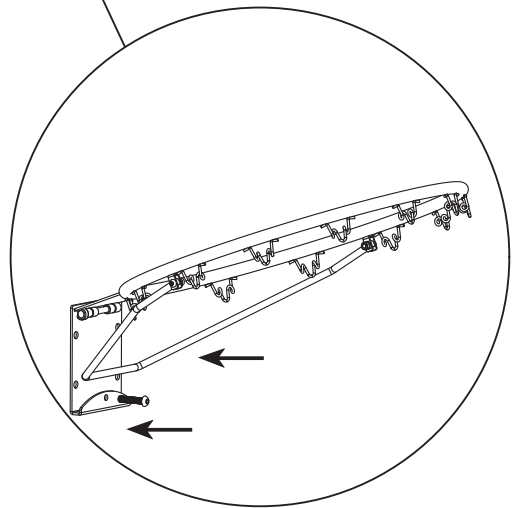
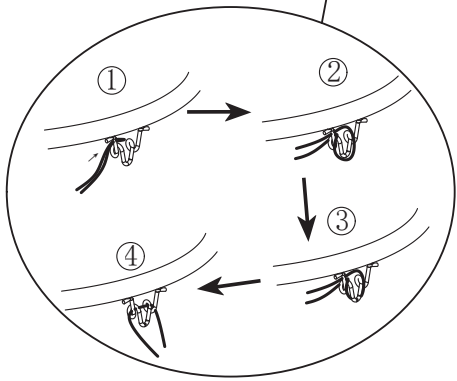
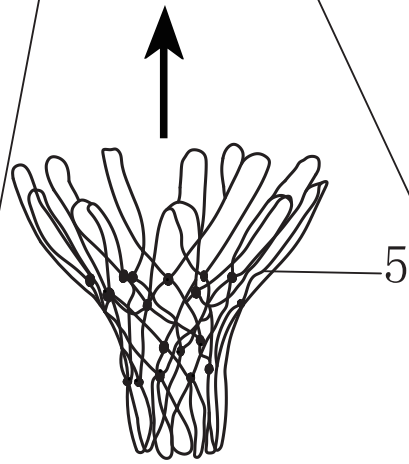
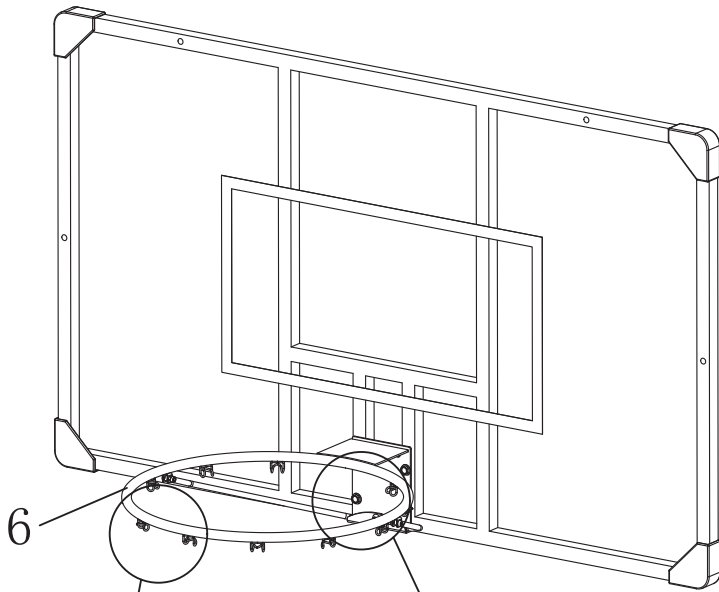

SPORTNOW

IN221000258V02_UK_FR_ES_PT_DE_IT

A61-039V00_A61-040V00

DE

Basketball Rückwand

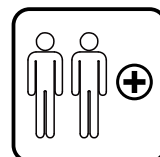
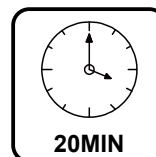
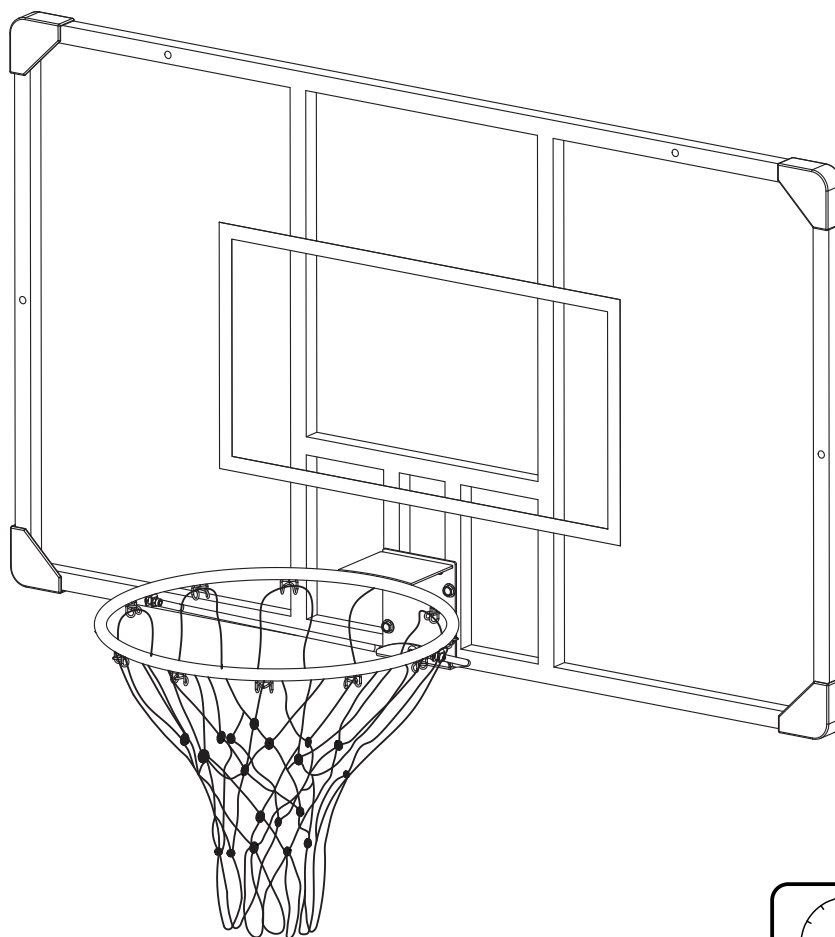

**WICHTIG, FÜR DIE SPÄTERE VERWENDUNG
AUFBEWAHREN: SORGFÄLTIG DURCHLESEN**

BENUTZERHANDBUCH

Allgemeine Sicherheitshinweise

- Für diesen Zusammenbau sind zwei kompetente Erwachsene erforderlich.
- Lesen und verstehen Sie das Handbuch, bevor Sie das Gerät zusammenbauen und verwenden.
- Eine Nichtbeachtung der Anweisungen kann zu Verletzungen oder Sachschäden führen.
- Wählen Sie einen sicheren Ort für den Einbau der Rückwand.
- Verwenden Sie die Leiter nur mit äußerster Vorsicht.
- Stellen Sie sicher, dass die Rückwand fest installiert ist.
- Hängen Sie sich nicht an die Rückwand und den Rand.
- Nehmen Sie den gesamten Inhalt aus dem Karton und stellen Sie sicher, dass er mit der Teileliste übereinstimmt.
- Geben Sie das Produkt nicht im Geschäft zurück, sondern wenden Sie sich bitte an den Kundendienst.

Wartung

- 1.Prüfen Sie regelmäßig, ob die Rückwand fest an der Wand oder der Befestigung angebracht ist. Wenn die Schrauben locker sind, müssen Sie sie festziehen.
- 2.Überprüfen Sie Ihre Basketballanlage regelmäßig auf lose Teile, übermäßige Abnutzung und Anzeichen von Korrosion.

Aus Sicherheitsgründen und um die Lebensdauer Ihrer Basketballanlage zu verlängern, müssen Sie die folgenden vorbeugenden Maßnahmen ergreifen.

(1)Überprüfen Sie alle Schrauben und Muttern. Falls welche locker sind, ziehen Sie sie fest.

(2)Überprüfen Sie alle Teile auf übermäßige Abnutzung und Verschleiß. Ersetzen Sie gegebenenfalls alle Teile, die durch die Verwendung abgenutzt oder beschädigt sind. Wenden Sie sich an unseren Kundendienst, um Ersatzteile zu ersetzen.

Hinweis: NICHT VOM RAND HÄNGEN

Stückliste

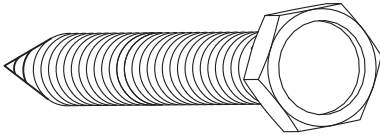
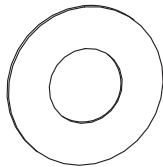
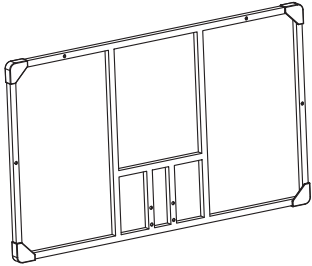
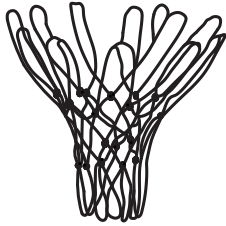
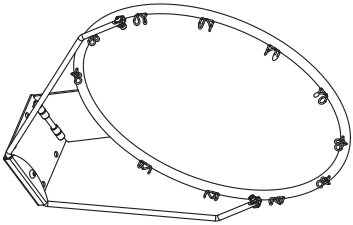
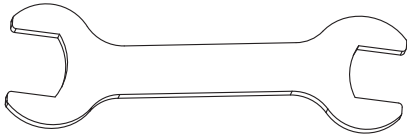
	BESCHREIBUNG	TEILABBILD	Menge
1	Dübel		8
2	Bolzen		8
3	Unterlegscheibe		8
4	Rückwand		1
5	Netz		1
6	Rand		1
7	Werkzeuge		1

Zusammenbau

Schritt 1

Suchen Sie eine geeignete Wand/Platte für das Ballspielen.

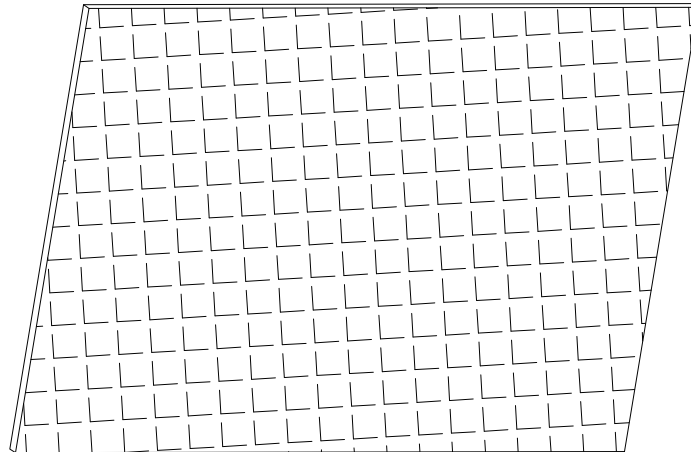

Schritt 2

Legen Sie die Rückwand (#4) auf die gewünschten Bereiche und bereiten Sie sie zum Bohren vor.

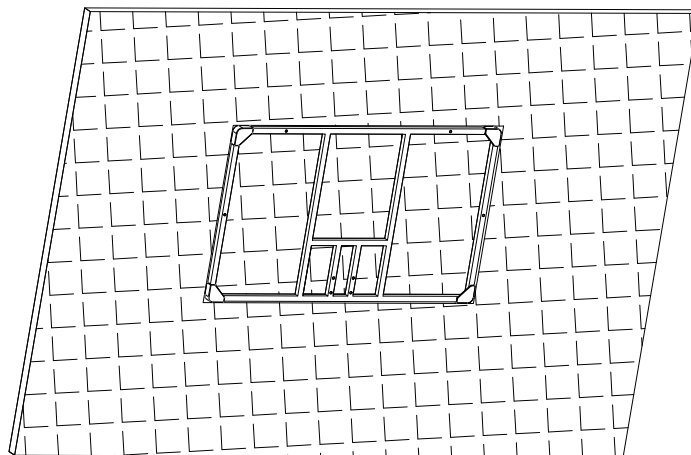

Schritt 3

Bohren Sie die Wand/Platte entsprechend der Position der Rückwand und stecken Sie den Dübel (#1 × 8) in die Bohrlöcher.

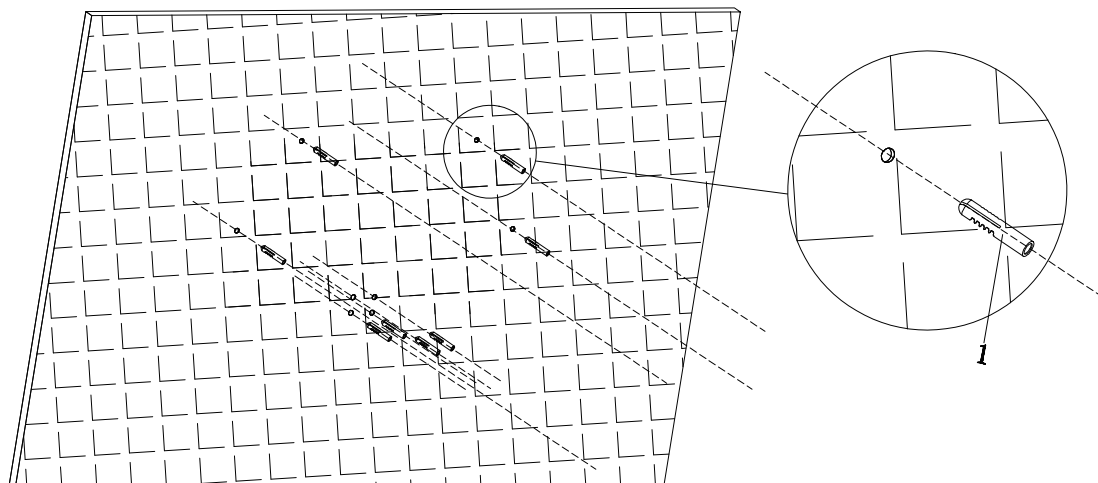

Schritt 4

Verriegeln Sie den Basketballkorb.

- Richten Sie die Rückwand (#4) mit den entsprechenden Löchern aus und setzen Sie 4 Sätze Bolzen (#2) und Unterlegscheiben (#3) ein. Ziehen Sie die Schrauben fest.
- Richten Sie den Rand (#6) mit den 4 Löchern an der Unterseite der Rückwand aus und setzen Sie 4 Sätze Bolzen (#2) und Unterlegscheiben (#3) ein. Ziehen Sie die Schrauben fest.
- Hängen Sie das Basketballnetz (#5) auf.
- Zusammenbau fertiggestellt.

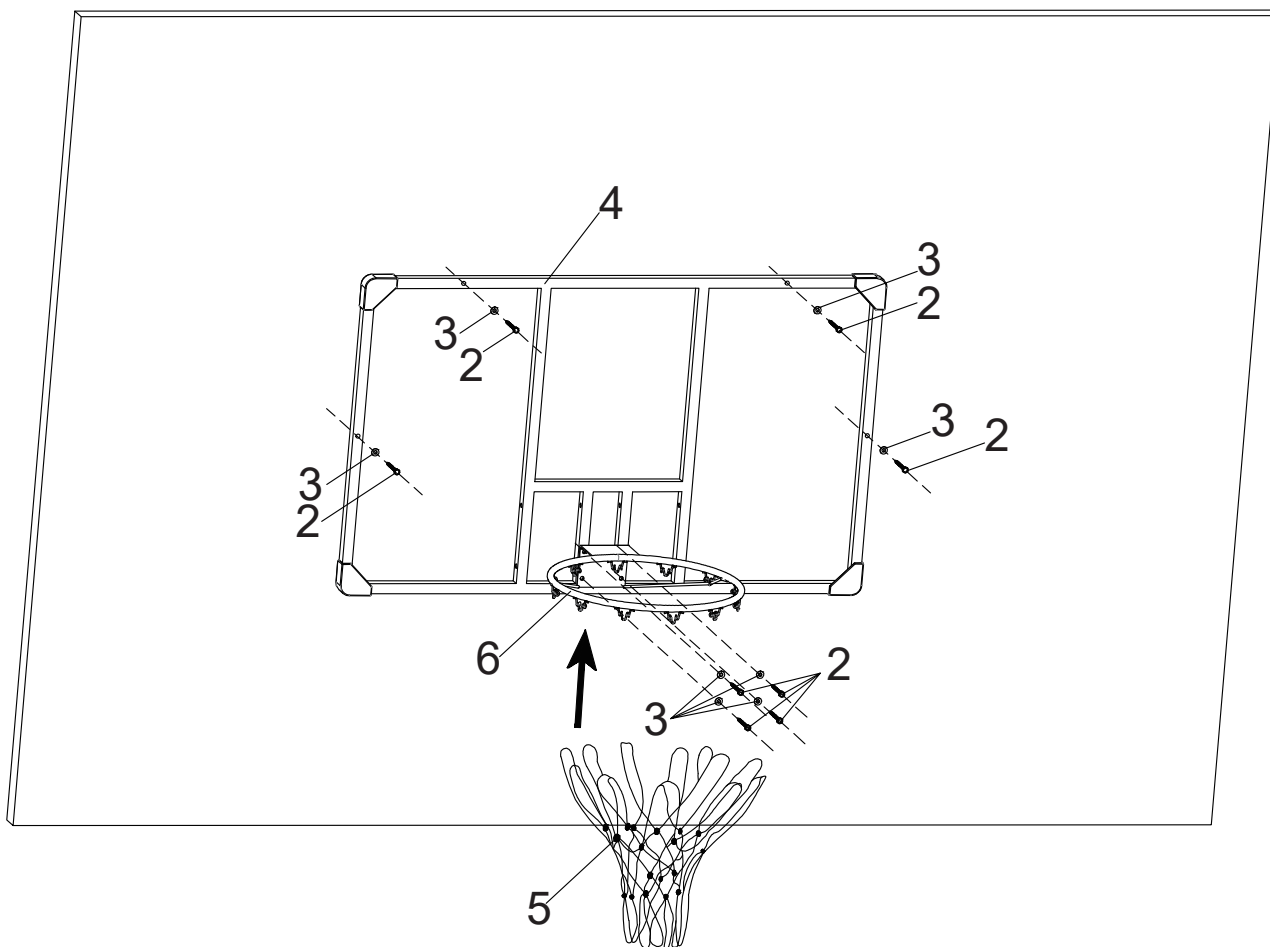

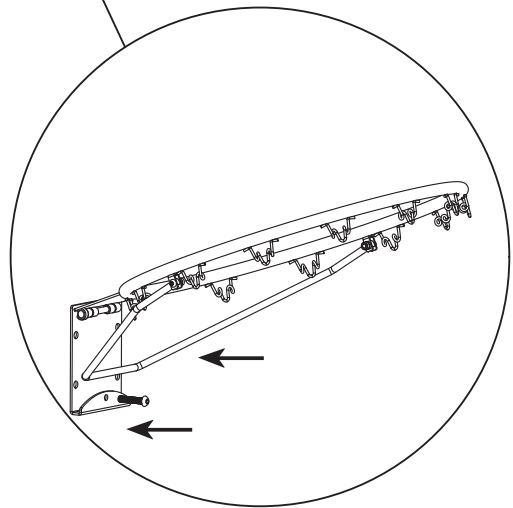
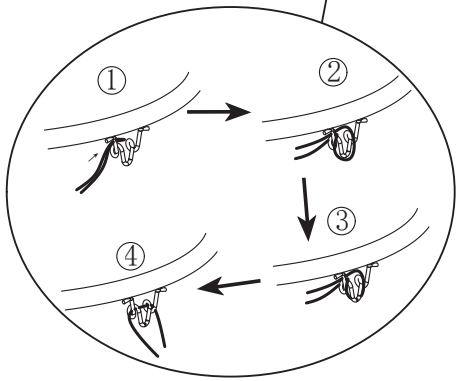
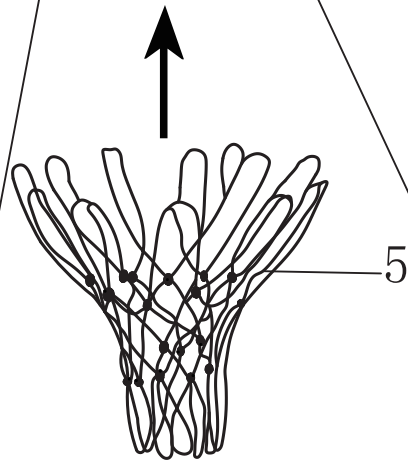
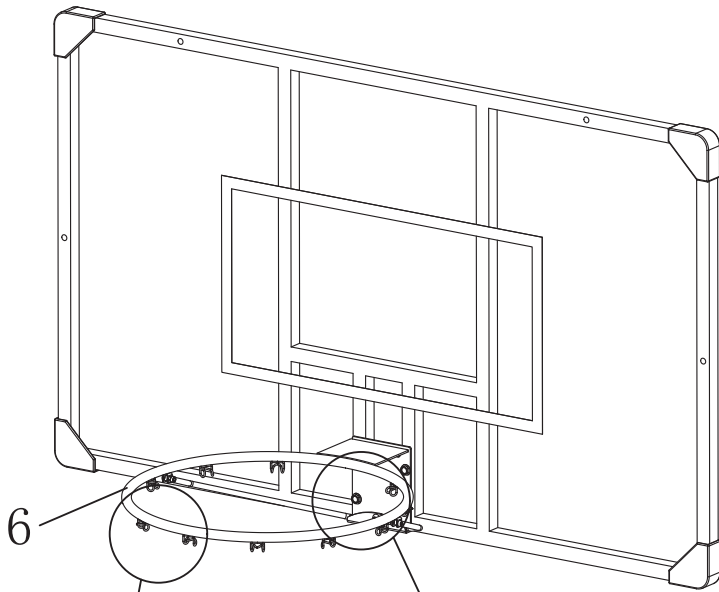

SPORTNOW

IN221000258V02_UK_FR_ES_PT_DE_IT

A61-039V00_A61-040V00

IT

Tabellone da basket

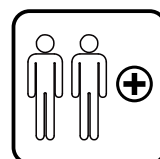
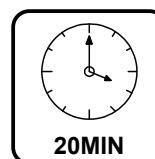
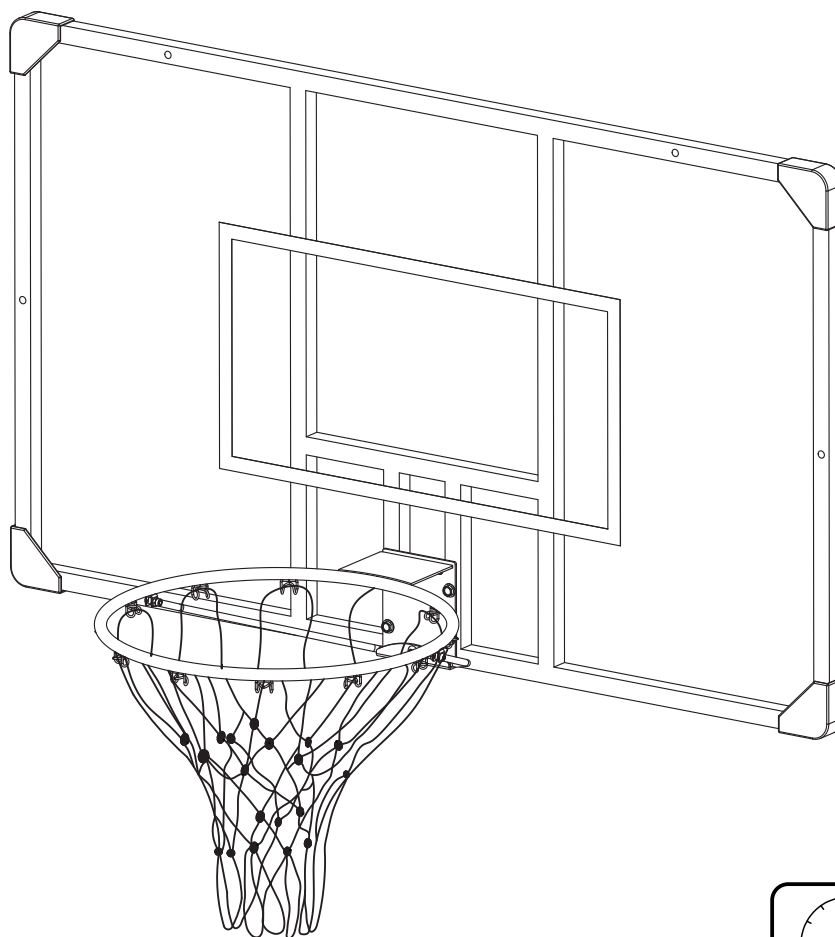

**IMPORTANTE - CONSERVARE QUESTE INFORMAZIONI
PER CONSULTARLE IN SEGUITO: LEGGERE ATTENTAMENTE**

ISTRUZIONI DI ASSEMBLAGGIO

Istruzioni di sicurezza generali

- Per questo montaggio sono necessarie due persone adulte in grado di farlo.
- Leggere e comprendere il manuale prima di montare e utilizzare l'unità.
- La mancata osservanza delle istruzioni potrebbe causare lesioni o danni alla proprietà.
- Scegliere un luogo sicuro per installare il tabellone.
- Usare estrema cautela quando si utilizza una scala.
- Assicurarsi che il tabellone sia saldamente installato.
- Non appendersi al tabellone e al cerchio.
- Rimuovere tutto il contenuto dalla scatola e verificare che corrisponda all'elenco delle parti.
- Non restituire il prodotto al negozio, contattare il servizio clienti.

Manutenzione

1. Controllare regolarmente se il tabellone è saldamente fissato al muro o al supporto di montaggio. È necessario stringere le viti se sono allentate.
2. Controllare frequentemente il sistema da basket per hardware allentato, usura eccessiva e segni di corrosione.

Per motivi di sicurezza e per prolungare la durata del sistema da basket, è necessario adottare le seguenti misure preventive.

- (1) Controllare tutte le dadi e le viti. Se qualcuno è allentato, stringerlo.
- (2) Controllare tutte le parti per usura eccessiva. Se necessario, sostituire eventuali parti usurate o danneggiate a causa dell'uso. Contattare il nostro servizio clienti per ricambi.

Nota: NON APPENDERSI AL CERCHIO

Stückliste

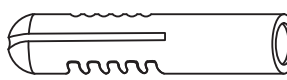
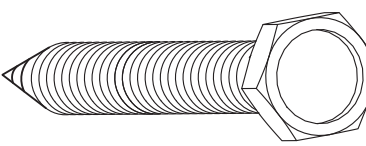
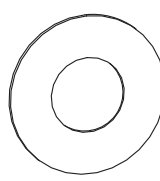
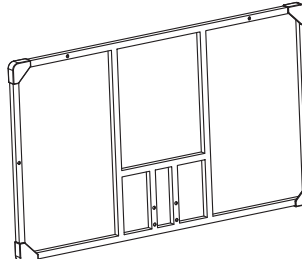
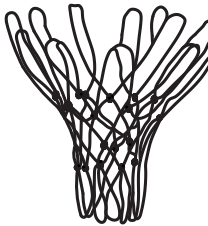
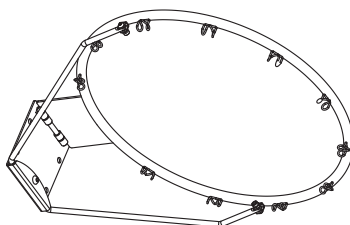
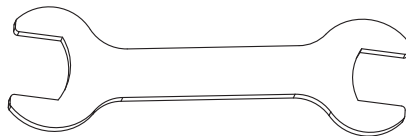
	BESCHREIBUNG	TEILABBILD	Menge
1	Dübel		8
2	Bolzen		8
3	Unterlegscheibe		8
4	Rückwand		1
5	Netz		1
6	Rand		1
7	Werkzeuge		1

Montaggio

Passo 1

Trova un muro/superficie adatta per il tiro a canestro.

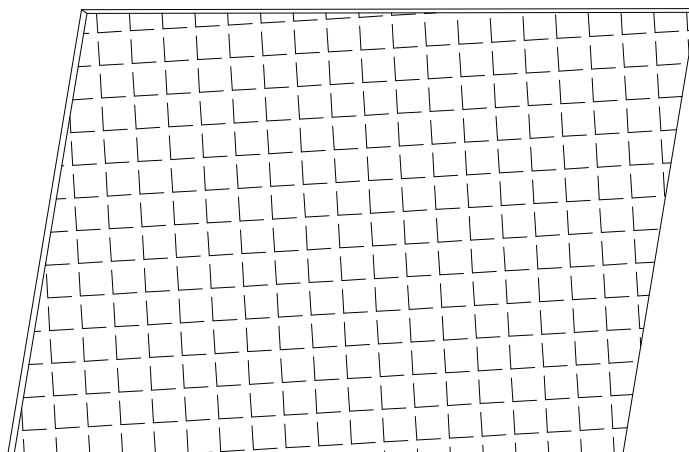

Passo 2

Posizionare il tabellone (#4) nelle aree desiderate per la perforazione.

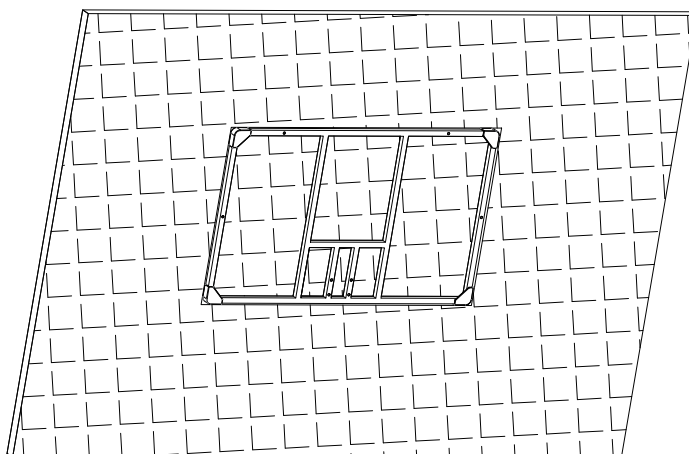

Passo 3

Fare dei fori nel muro/superficie secondo la posizione del tabellone e inserire i tasselli (#1 * 8) nei fori.

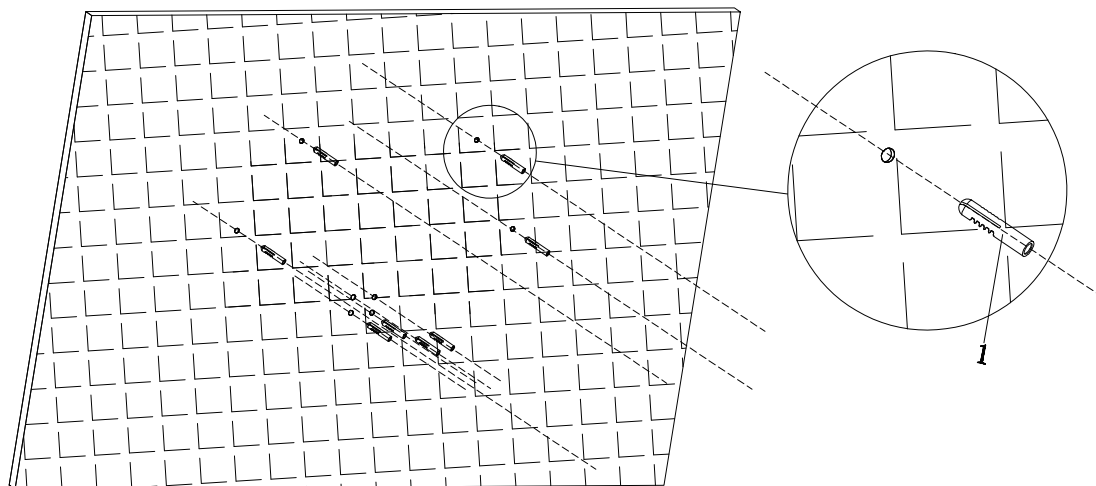

Passo 4

Bloccare il canestro da basket.

- Allineare il tabellone (#4) con i fori corrispondenti e inserire 4 set di viti (#2) e rondelle (#3). Stringere le viti.
- Allineare il cerchio (#6) con i 4 fori situati nella parte inferiore del tabellone e inserire 4 set di viti (#2) e rondelle (#3). Stringere le viti.
- Appendere la rete da basket (#5).
- Montaggio completato.

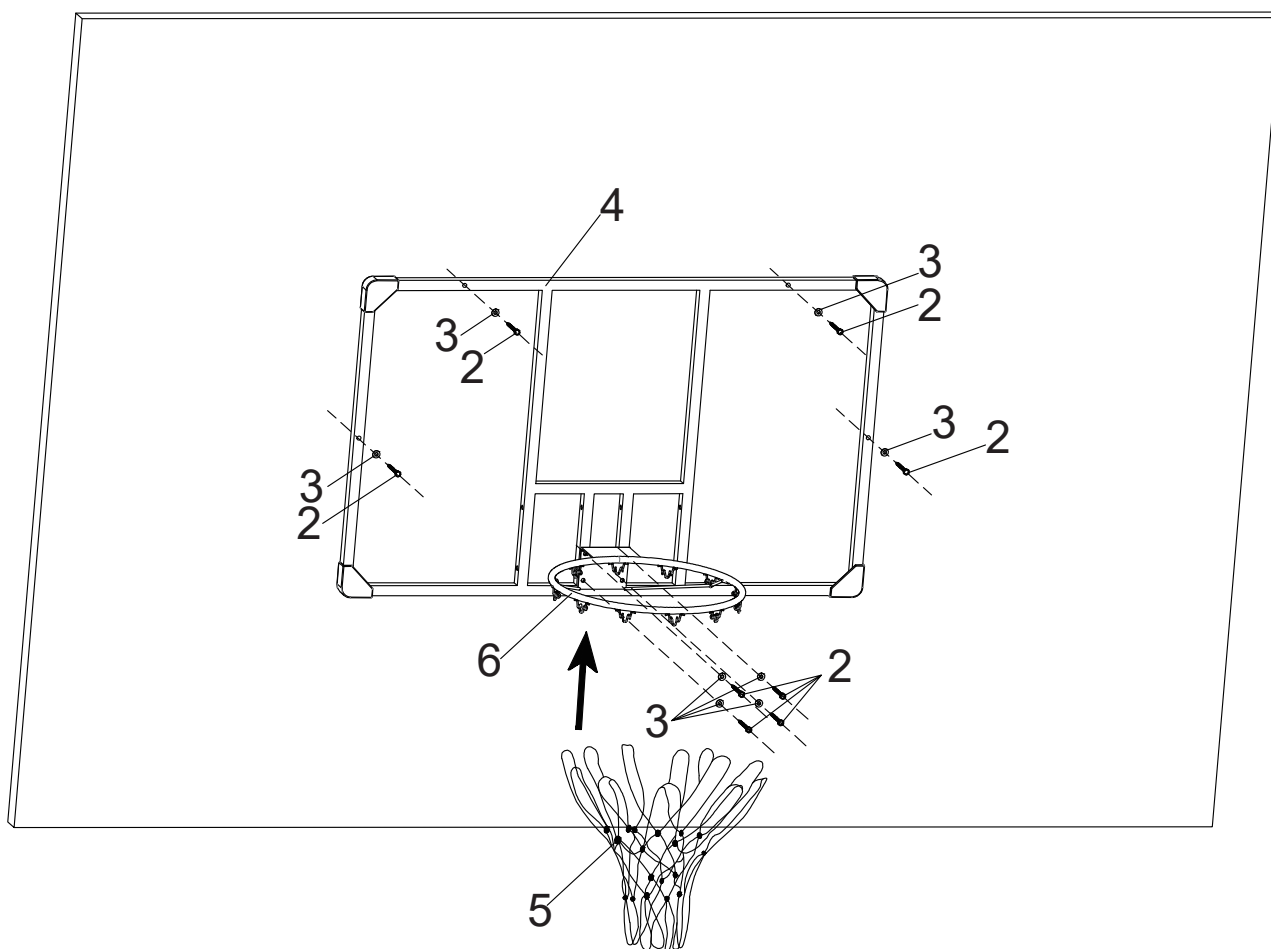

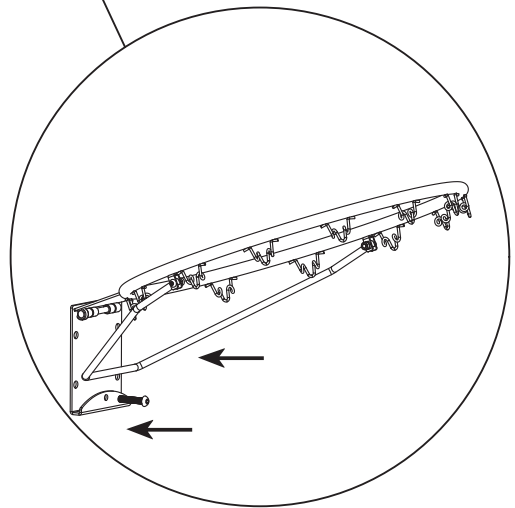
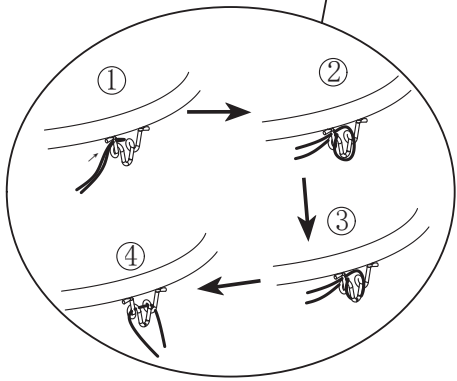
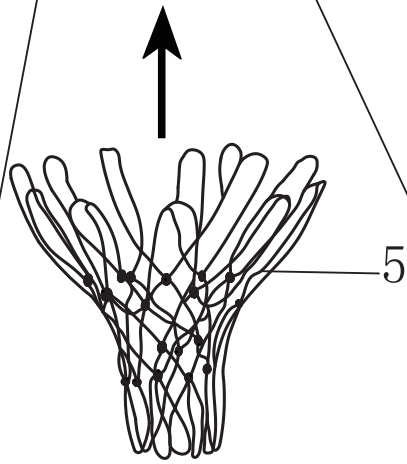
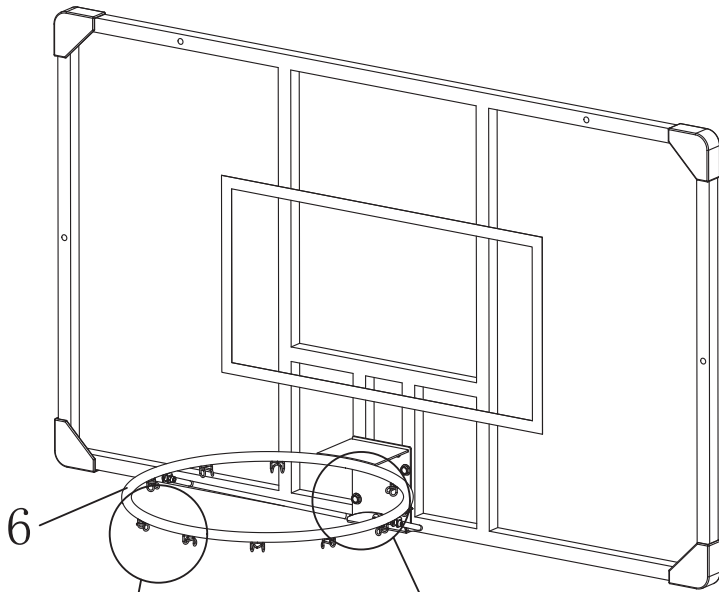

UK

If you have any questions, please contact our customer care centre.

Our contact details are below:



0044-800-240-4004



enquiries@mhstar.co.uk

IMPORTER ADDRESS:

MH STAR UK Ltd
1 Northampton Cross Logistics Park
Northampton Cross Road
Northampton
NN4 9FH
MADE IN CHINA

ES

Si tiene alguna pregunta, comuníquese con nuestro Centro de Atención al Cliente. Nuestros datos de contacto son los siguientes:



0034-931294512



atencioncliente@aosom.es

Importador/Fabricante/REP:

Spanish Aosom, S.L.
C/ Roc Gros, nº 15. 08550, Els Hostalets de Balenyà, Spain.
B66295775
atencioncliente@aosom.es
TEL: 931294512
HECHO EN CHINA

FR

Si vous avez la moindre question, veuillez contacter notre centre d'assistance à la clientèle.

Nos coordonnées sont les suivantes:



0033-1-84166106



aosom@mhfrance.fr

Importé par/Fabricant/REP:

MH France
2, rue Maurice Hartmann
92130 Issy-les-Moulineaux
France
FABRIQUÉ EN CHINE

PT

Se tiver alguma dúvida, por favor contacte o nosso Centro de Atendimento ao Cliente. Os nossos dados de contacto são os seguintes:



0034-931294512



info@aosom.pt.

IMPORTADOR:

SPANISH AOSOM, S.L
C.ROC GROS N.15, 08550. ELS HOSTALETES DE BALENYÀ
TEL: 931294512 (SEG-SEX DAS 7:30H ÀS 16:30H)
INFO@AOSOM.PT
WWW.AOSOM.PT

DE

Wenn Sie Fragen haben, wenden Sie sich bitte an unser Kundendienstzentrum.

Unsere Kontaktdaten stehen unten:



0049-0(40)-87408465



service@aosom.de

Importeur/Hersteller/REP:

MH Handel GmbH
Wendenstraße 309
D-20537 Hamburg
Germany
IN CHINA HERGESTELLT

IT

In caso di dubbio, si prega di contattare il nostro centro assistenza clienti. I nostri dettagli di contatto sono di seguito:



0039-0249471447



clienti@aosom.it

IMPORTATO DA/Produttore/REP:

AOSOM Italy srl
Centro Direzionale Milanofiori
Strada 1 Palazzo F1
20057 Assago (MI)
P.I.: 08567220960
FATTO IN CINA