

Soozier

IN220800272V03_US_CA

A91-116_A91-116V01

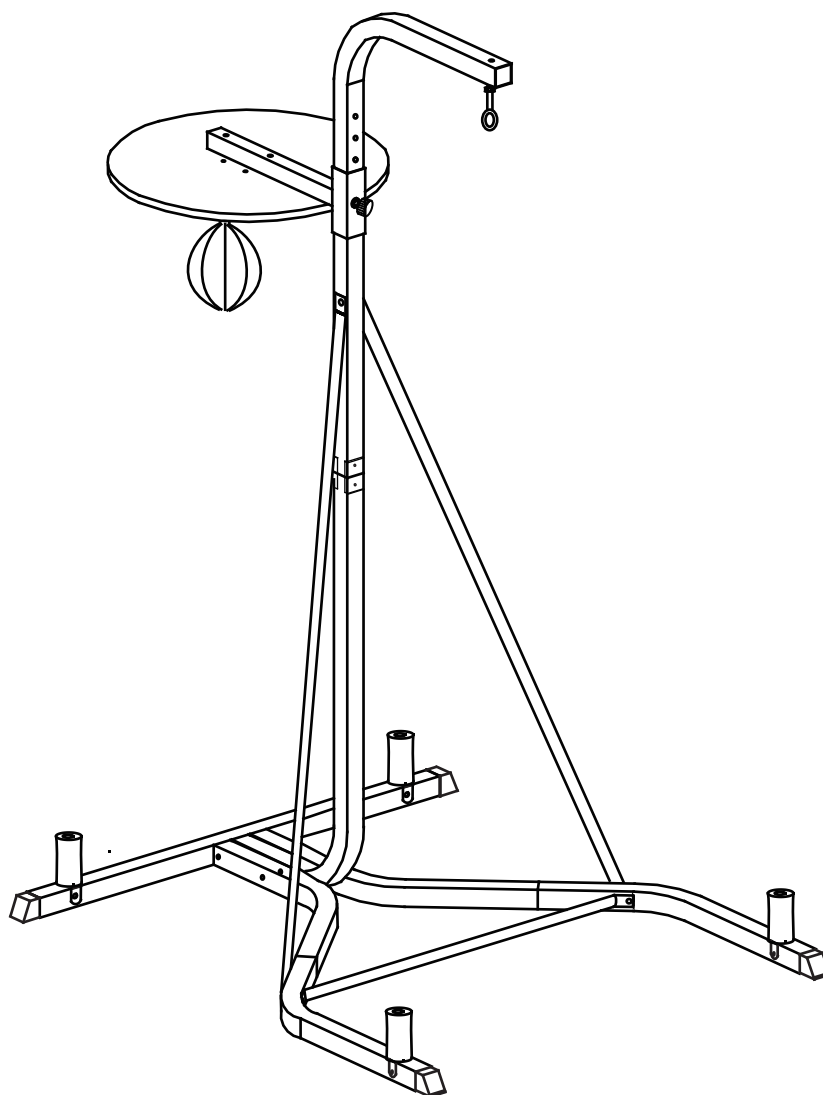

Max 150kg

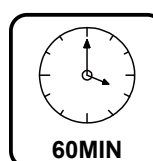

60MIN

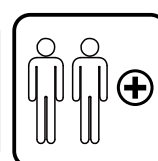

EN_IMPORTANT, RETAIN FOR FUTURE REFERENCE: READ CAREFULLY.

FR_IMPORTANT: A LIRE ATTENTIVEMENT ET A CONSERVER POUR VOUS Y REFRERER ULTERIEUREMENT

WARNING:

- Before using your freestanding boxing ball, you are urged to contact a physician to be sure that your hands, wrists, elbows, shoulders and back are suitably conditioned to withstand the rigors of punching this equipment.
- When using this equipment be sure that you are in good physical condition and under expert supervision. Before each and every use be sure that the equipment is in good condition and properly fastened.
- It is recommended that you use well-padded leather bag gloves together with hand wraps. They provide a degree of protection but it is not warranted that this will avoid any injury.
- Don't always hit the same one point. So that the boxing stand will not tilt to one side. For safety reasons, we recommend that sand be used instead of water to fill the Base. If a leak develops, water could run out unnoticed, allowing the system to fall over, resulting in serious personal injuries, or property damage.
- If using Water, check the Base carefully for leaks. If a leak is found, lay the system down on the ground and call Customer Service. Do not use, stand up, or play on a leaking system.

MAINTENANCE AND CARE











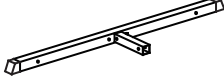



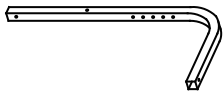
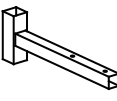

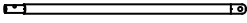
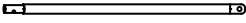
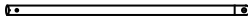

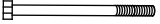





- Keep all instructions and parts relating to this product for future reference.
- Inspect the boxing stand before each use and replace any worn, defective or missing parts.
- Avoid high temperature, moisture or direct sunlight, please place in a well-ventilated place.
- When you accidentally wet the product, use a dry cloth to avoid skidding.
- Neutral detergent can be used to dilute the water to wipe the cloth carefully wipe the oil, and then dry with a dry cloth.

AVERTISSEMENT:

- Avant d'utiliser votre ballon de boxe autoportant, nous vous conseillons vivement de contacter un médecin afin de vous assurer que vos mains, vos poignets, vos coudes, vos épaules et votre dos sont convenablement conditionnés pour supporter les rigueurs de la frappe de cet équipement.
- Lorsque vous utilisez cet équipement, assurez-vous d'être en bonne condition physique et sous la surveillance d'un expert. Avant chaque utilisation, assurez-vous que l'équipement est en bon état et correctement fixé.
- Il est recommandé d'utiliser des gants en cuir bien rembourrés ainsi que des enveloppes pour les mains. Ils offrent un certain degré de protection mais il n'est pas garanti que cela évite toute blessure.
- Ne frappez pas toujours le même point. Afin que le support de boxe ne bascule pas d'un côté. Pour des raisons de sécurité, nous recommandons d'utiliser du sable plutôt que de l'eau pour remplir le socle. En cas de fuite, l'eau pourrait s'écouler sans qu'on s'en aperçoive, ce qui entraînerait la chute du système et provoquerait des blessures graves, ou des dommages matériels.
- Si vous utilisez de l'eau, vérifiez soigneusement que la Base ne présente pas de fuites. Si vous constatez une fuite, posez le système sur le sol et appelez le service clientèle. N'utilisez pas, ne redressez pas et ne jouez pas sur un système qui fuit.

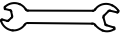
MAINTENANCE ET ENTRETIEN

- Conservez toutes les instructions et pièces relatives à ce produit pour vous y référer ultérieurement.
- Inspectez le support de boîte avant chaque utilisation et remplacez toute pièce usée, défectueuse ou manquante.
- Veillez à éviter une exposition aux températures élevées, à l'humidité ou à la lumière directe du soleil, veuillez le placer dans un endroit bien ventilé.
- Lorsque le produit a été accidentellement mouillé, utilisez un chiffon sec pour prévenir tout dérapage.
- Un détergent neutre peut être utilisé pour diluer l'eau pour essuyer le chiffon soigneusement l'huile, puis séchez avec un chiffon sec.

| | | | |
|---|---|--|---|
| <p>1</p>  <p>x 2</p> | <p>2</p>  <p>x 1</p> | <p>3</p>  <p>x 1</p> | <p>4</p>  <p>x 2</p> |
| <p>5</p>  <p>x 4</p> | <p>6</p>  <p>x 1</p> | <p>7</p>  <p>x 1</p> | <p>8</p>  <p>x 1</p> |
| <p>9</p>  <p>x 1</p> | <p>10</p>  <p>x 1</p> | <p>11</p>  <p>x 2</p> | <p>12</p>  <p>x 1</p> |
| <p>13</p>  <p>x 4</p> | <p>14</p>  <p>x 2 M10x150mm</p> | <p>15</p>  <p>x 2 M10x80mm</p> | <p>16</p>  <p>x 11 M10x65mm</p> |
| <p>18</p>  <p>x 4 M6x40mm</p> | <p>19</p>  <p>x 1 M10 thicker</p> | <p>20</p>  <p>x 32 M10</p> | <p>21</p>  <p>x 4 M6</p> |
| <p>23</p>  <p>x 1 M10 nut</p> | <p>24</p>  <p>x 4 M6</p> | <p>25</p>  <p>x 1</p> | <p>26</p>  <p>x 1</p> |
| <p>28</p>  <p>x 2</p> | <p>29</p>  <p>x 1</p> | <p>30</p>  <p>x 2</p> | <p>31</p>  <p>x 1</p> |
| <p>33</p>  <p>x 1</p> | <p>32</p>  <p>x 1</p> | | |

01

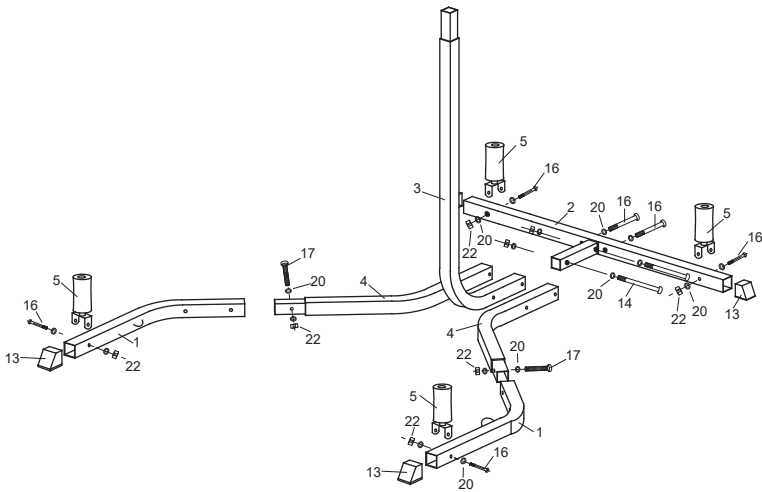

02

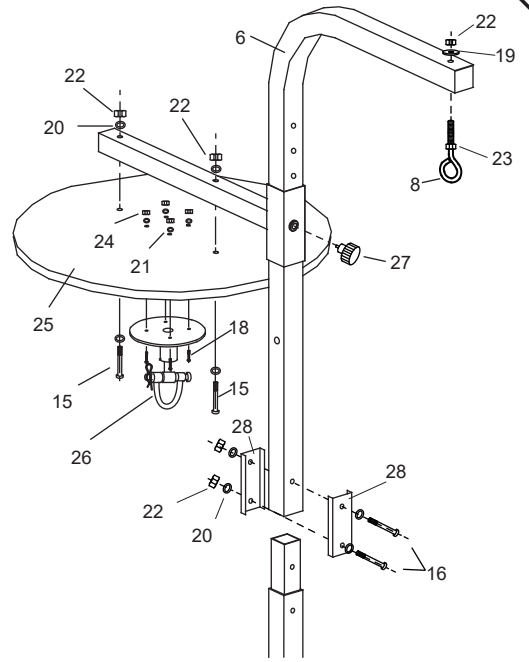

03

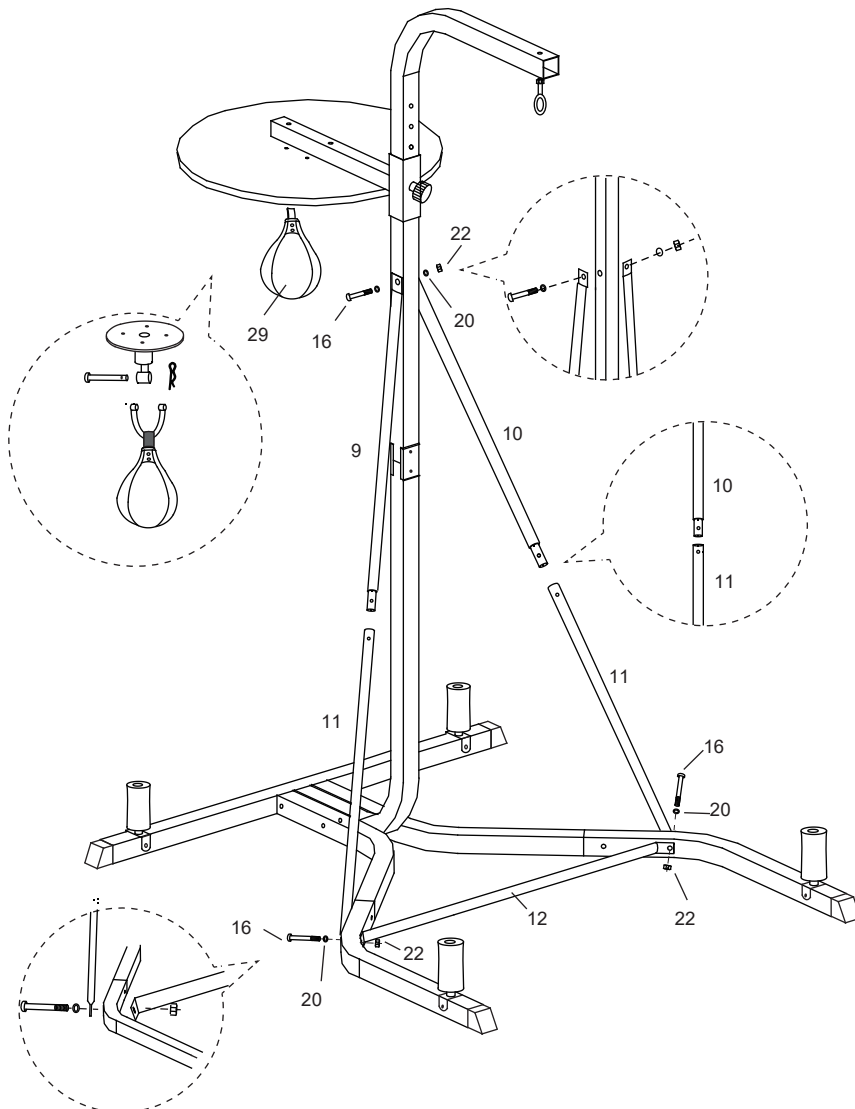

Done

US

If you have any questions, please contact our customer care center.
Our contact details are below:



001-877-644-9366



customerservice@aosom.com

Imported by Aosom LLC
7777 Center Ave. Suite 430
Huntington Beach, CA 92647-9998 USA
MADE IN CHINA

CA

If you have any questions, please contact our customer care center.
Our contact details are below:

Si vous avez la moindre question, veuillez contacter notre centre d'assistance à la clientèle.
Nos coordonnées sont les suivantes:



416-792-6088



customerservice@aosom.ca

Imported by Aosom Canada Inc.
Unit 33-1 Sparks Avenue, North York, Ontario, Canada
M2H 2W1
MADE IN CHINA

Importé par Aosom Canada Inc.
Unité 33-1 Sparks Avenue, North York, Ontario, Canada
M2H 2W1
FABRIQUÉ EN CHINE