

IMPORTANT, RETAIN FOR FUTURE REFERENCE: READ CAREFULLY

ASSEMBLY INSTRUCTION

Important Safety Information

Please keep this manual in a safe place for reference.





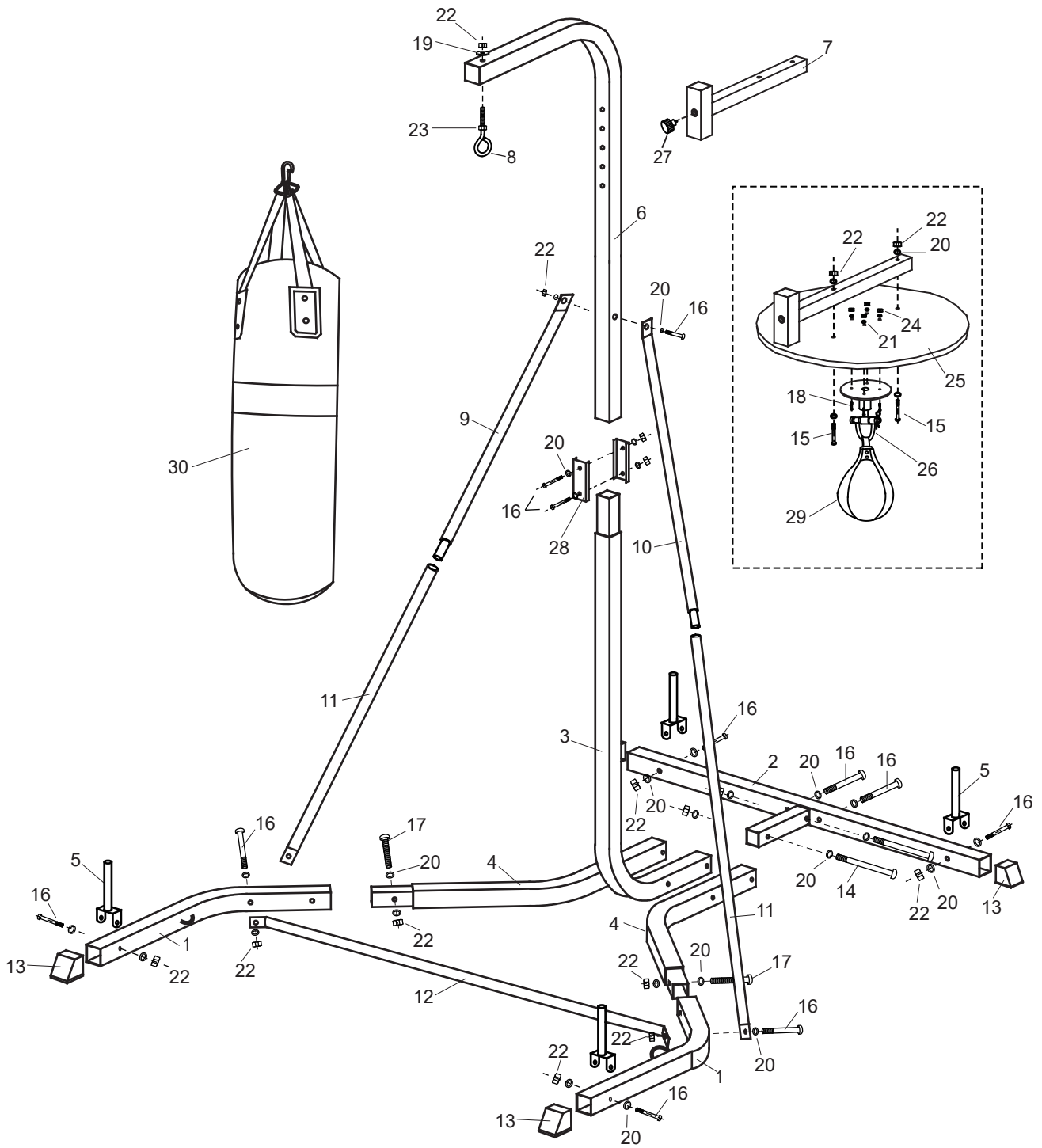





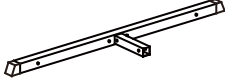



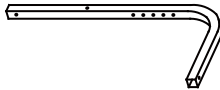
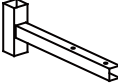

1. It is important to read this entire manual before assembling and using the equipment. Safe and efficient use can only be achieved if the equipment is assembled, maintained and used properly. It is your responsibility to ensure that all users of the equipment are informed of all warnings and precautions.
2. Before starting any exercise program you should consult your doctor to determine if you have any physical or health conditions that could create a risk to your health and safety, or prevent you from using the equipment properly. Your doctor's advice is essential if you are taking medication that affects your heart rate, blood pressure or cholesterol level.
3. Be aware of your body's signals. Incorrect or excessive exercise can damage your health. Stop exercising if you experience any of the following symptoms: Pain, tightness in your chest, irregular heartbeat, extreme shortness of breath, feeling light headed, dizzy or nauseous. If you do experience any of these conditions you should consult your doctor before continuing with your exercise program.
4. Keep children and pets away from the equipment. The equipment is designed for adult use only.
5. Use the equipment on a solid, flat level surface with a protective cover for your floor or carpet. For safety, the equipment should have at least 0.5 meter of free space all around it.
6. Before using the equipment, check the nuts and bolts are securely tightened.
7. The safety level of the equipment can only be maintained if it is regularly examined for damage and/or wear and tear.
8. Always use the equipment as indicated. If you find any defective components whilst assembling or checking the equipment, or if you hear any unusual noise coming from the equipment during use, stop. Do not use the equipment until the problem has been rectified.
9. Wear suitable clothing whilst using the equipment. Avoid wearing loose clothing which may get caught in the equipment or that may restrict or prevent movement.
10. The equipment is not suitable for therapeutic use.
11. Care must be taken when lifting or moving the equipment so as not to injure your back. Always use proper lifting techniques and/or use assistance.

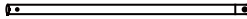
EXPLODED-VIEW ASSEMBLY DRAWING















PACKING DETAILS: TOTAL 2 BOXES

BOX-1/2

1  x 2	2  x 1	3  x 1	4  x 2
5  x 4	6  x 1	7  x 1	8  x 1
9  x 1	10  x 1	11  x 2	12  x 1
13  x 4	25  x 1	26  x 1	27  x 1
29  x 1	34  x 1	28  x 2	

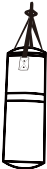
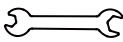
BOX-2/2

14  M10x150mm x 2	15  M10x70mm x 2	16  M10x65mm x 11	17  M10x60mm x 2	18  M6x30mm x 4
19  M10 thicker x 1	20  M10 x 32	21  M6 x 4	22  M10 nylon nut x 16	23  M10 nut x 1
24  M6 x 4	30  x 1	31  x 2	32  x 1	33  x 1

ASSEMBLY DRAWING

Step 1

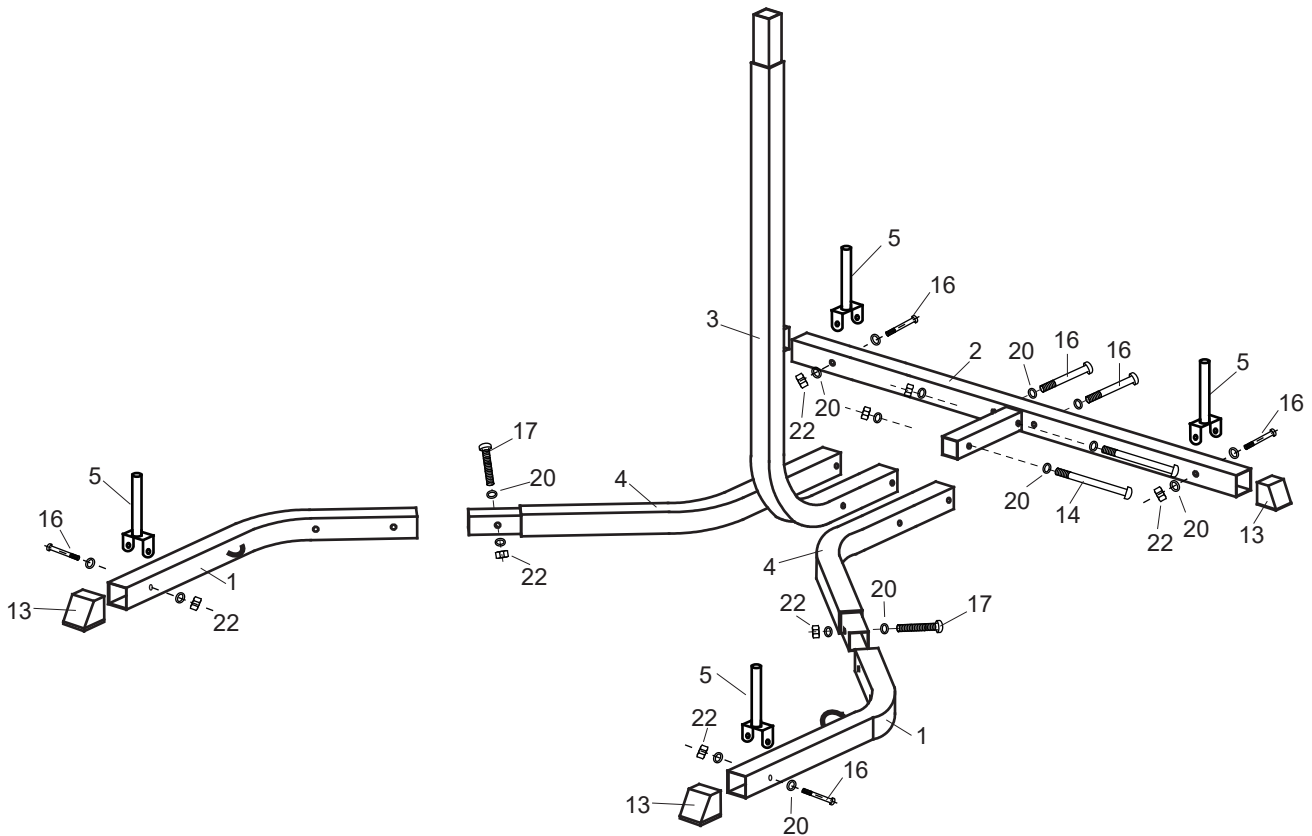

Assembly of the base frame

- 1) Assemble the foot cap (13) to the front base tube(1) and back base tube (2).
- 2)Screw together the base pipe (4) and front base tube (1), secured with M10x60 hex bolt (17-2pcs), M10 washer (20-4pcs) and M10 Nylon Nut (22- 2pcs).
- 3)Screw together the base tube (4) and lower stand tube(3) to the back base tube (2), secured with M10x150 hex bolt (14-2pcs), M10x 65 hex bolt (16-2pcs), M10 washer (20-6pcs) and M10 nylon nut (22-2pcs).
- 4)Screw together the weight plate tube (5) to the back base tube (2) and front base tube (1), secured with M10x65 hex bolt (16-4pcs), M10 washer (20-8pcs) and M10 nylon nut (22-4pcs).

Step 2

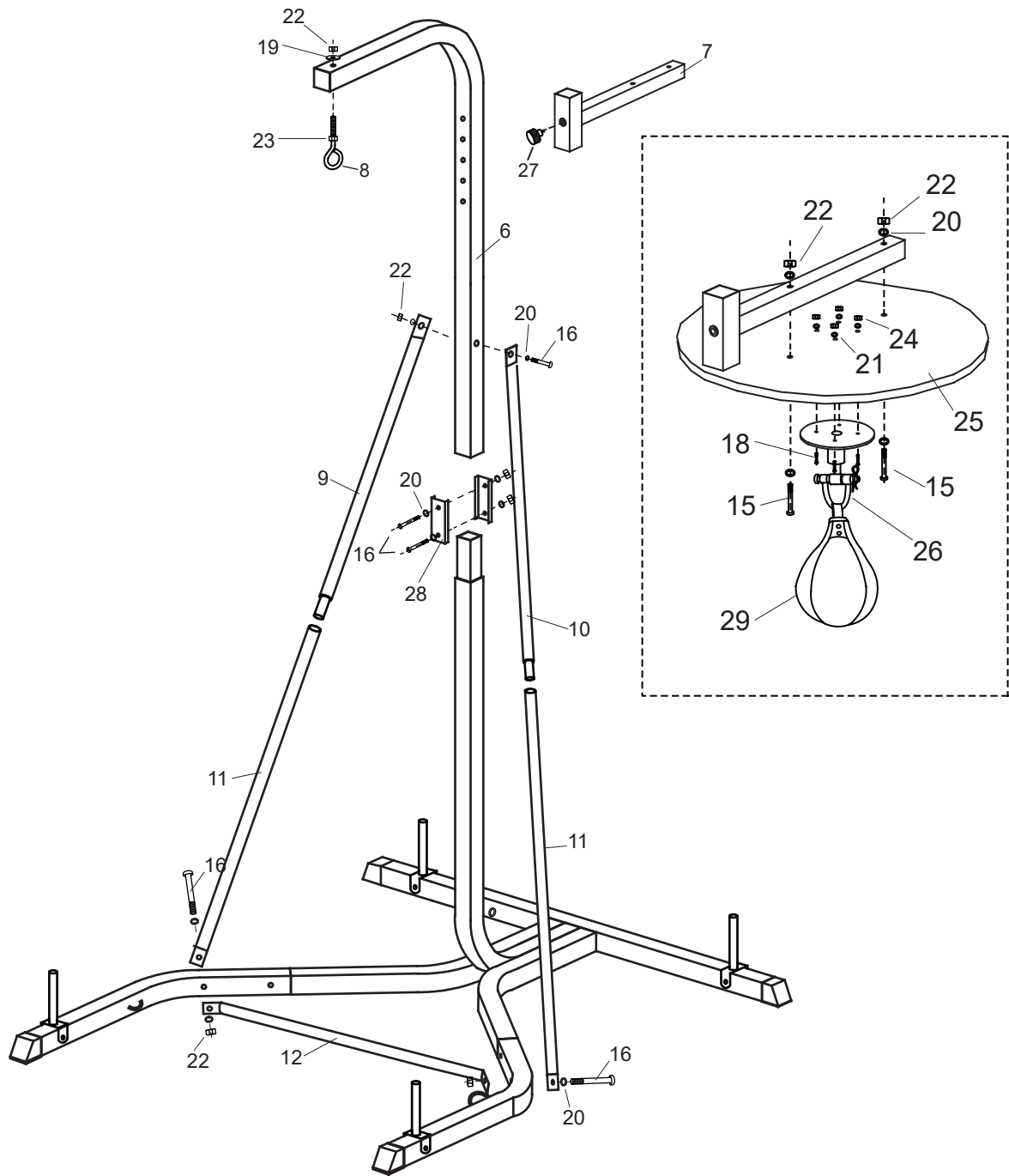

Assembly of the stand tube

- 1) Attach the speedball hook (26) and platform (25) to the adjustable tube (7), secured with M 10x 70 bolt (15-2pcs), M6x 40 bolt (18-4pcs), M10 washer (20-4pcs), M10 nylon nut (22-2pcs), M6 washer (21-4pcs) and M6 nylon nut (24-4pcs).
- 2) Insert the adjustable tube (7) to the upper stand tube (6), locked with quick pin (27).

- 3) Screw together the upper stand tube (6) to lower stand tube (3), secured with support plate(28-2pcs), hex bolt M10x65 hex bolt (16-2pcs), M10 washer (20-4pcs) and M10 nylon nut (22-2pcs).
- 4) Attach the upper brace tube left (9) and upper brace tube right (10) to lower brace tube (11).
- 5) Screw together the brace tube to base tube (1) and upper stand tube (6), secured with M10x65 hex bolt (16-3pcs), M10 washer (20-6pcs) and M10 nylon nut (22-3pcs).
- 6) Screw together the hook (8) to upper stand tube (6), secured with M10 washer (19-1pc), M10 nylon nut (22-1pc) and M10 nut (23-1pc).

EXERCISE INSTRUCTIONS

Using the equipment will provide you with several benefits, it will improve your physical fitness, tone muscle and in conjunction with a calorie controlled diet help you lose weight.

1. The Warm Up Phase

This stage helps get the blood flowing around the body and the muscles working properly. It will also reduce the risk of cramp and muscle injury. It is advisable to do a few stretching exercises as shown below. Each stretch should be held for approximately 30 seconds, do not force or jerk your muscles into a stretch - if it hurts, **STOP**.

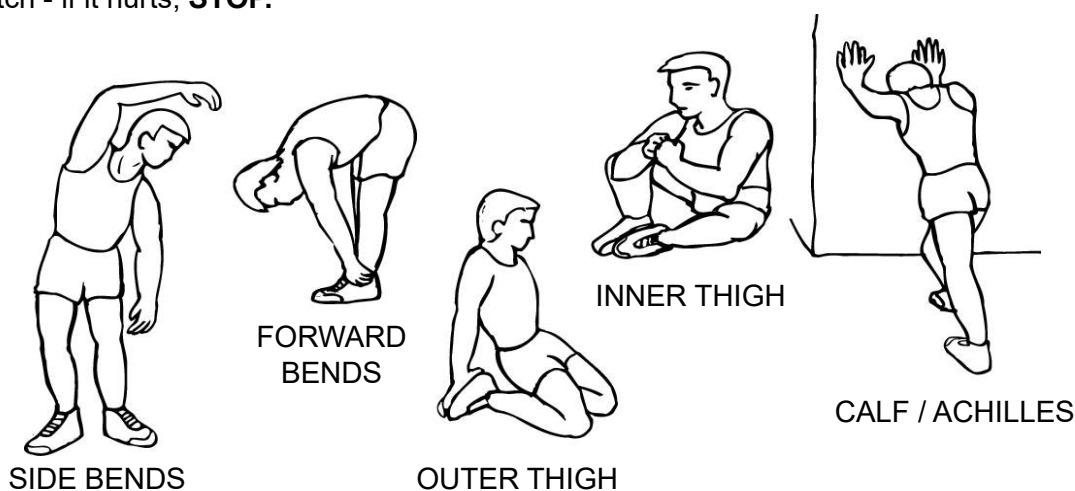

2. The Cool Down Phase

This stage is to let your Cardio-vascular System and muscles wind down. This is a repeat of the warm up exercise e.g. reduce your tempo, continue for approximately 5 minutes. The stretching exercises should now be repeated, again remembering not to force or jerk your muscles into the stretch.

As you get fitter you may need to train longer and harder. It is advisable to train at least three times a week, and if possible space your workouts evenly throughout the week.

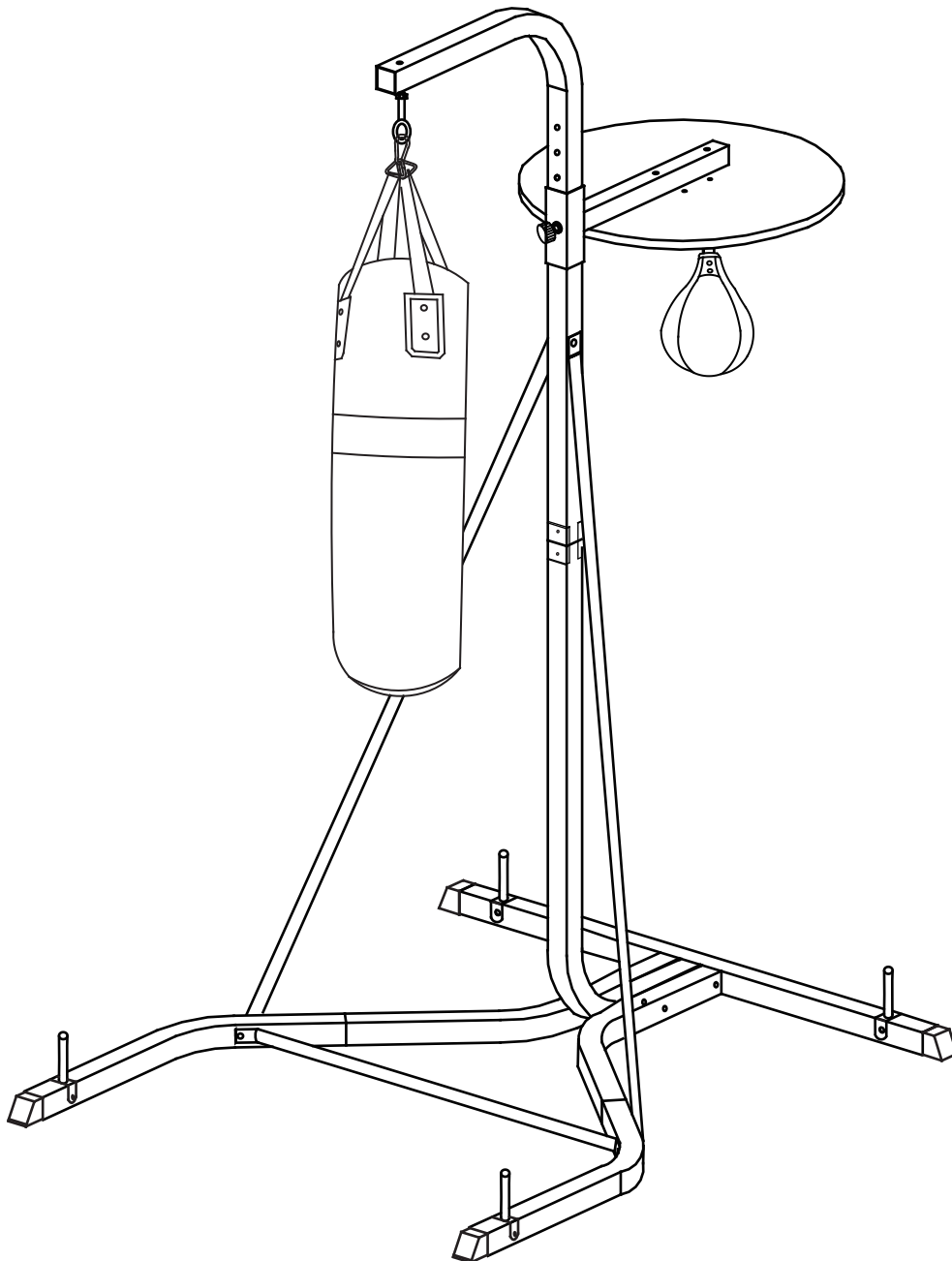

IMPORTANT - CONSERVEZ CES INFORMATIONS
POUR VOTRE CONSULTATION ULTÉRIEURE: LISEZ ATTENTIVEMENT

INSTRUCTIONS D'ASSEMBLAGE

Importantes Consignes de sécurité

Veillez conserver ce manuel dans un endroit sûr pour pouvoir vous y référer ultérieurement.





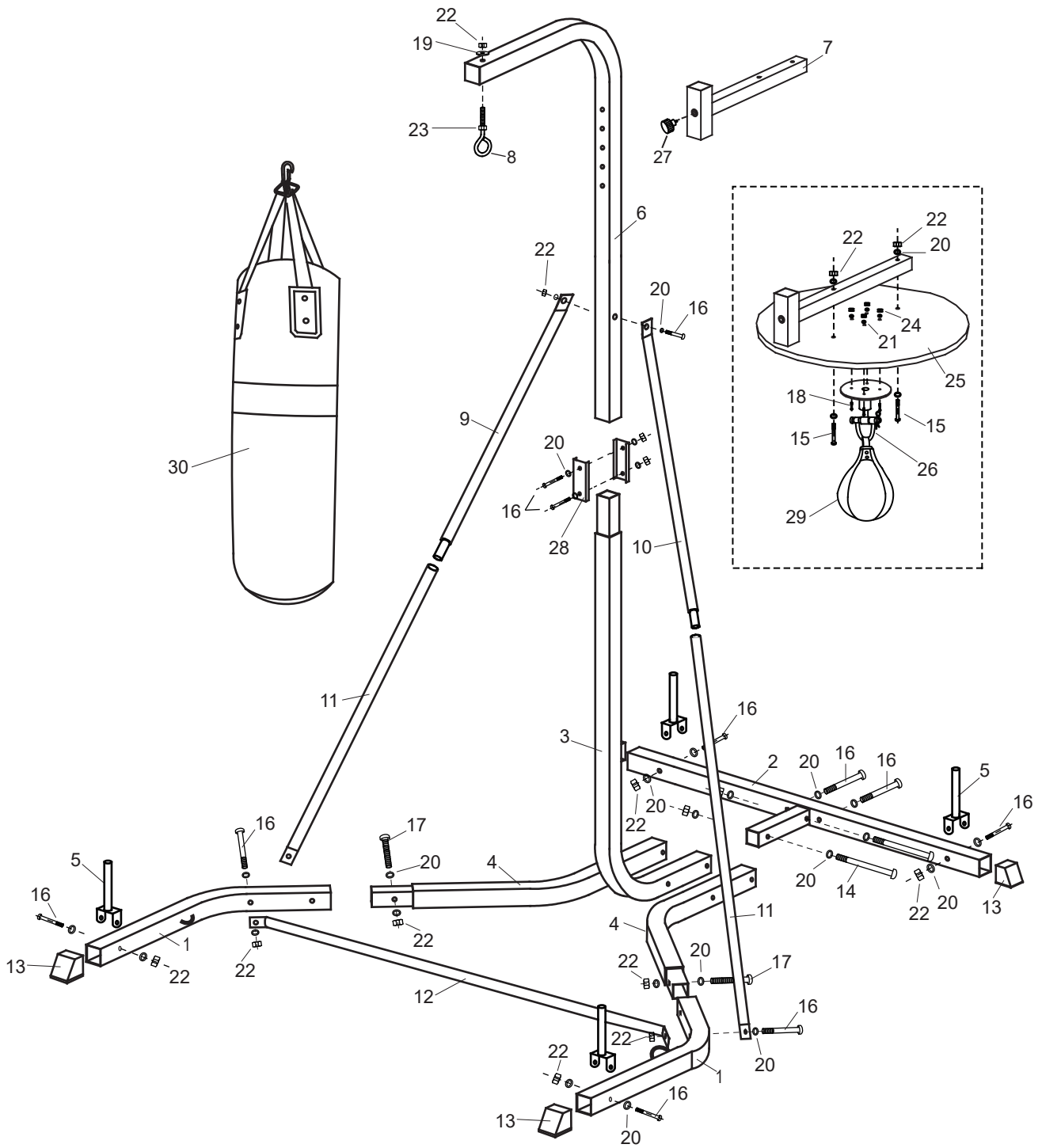





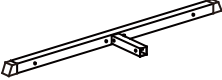



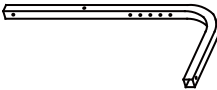
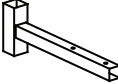

1. Il est important de lire ce manuel dans son intégralité avant d'assembler et d'utiliser l'équipement.
Une utilisation sûre et efficace ne peut être obtenue que si l'équipement est assemblé, entretenu et utilisé correctement. Il est de votre responsabilité de vous assurer que tous les utilisateurs de l'équipement sont informés de tous les avertissements et précautions.
2. Avant de commencer un programme d'exercice physique, vous devez consulter votre médecin pour déterminer si vous avez des problèmes physiques ou de santé qui pourraient créer un risque pour votre santé et votre sécurité, ou vous empêcher d'utiliser l'équipement correctement. L'avis de votre médecin est essentiel si vous prenez des médicaments qui affectent votre rythme cardiaque, votre tension artérielle ou votre taux de cholestérol.
3. Soyez attentif aux signaux de votre corps. Un exercice physique incorrect ou excessif peut nuire à votre santé. Cessez de faire de l'exercice si vous présentez l'un des symptômes suivants : Douleur, serrement de poitrine, rythme cardiaque irrégulier, essoufflement extrême, sensation de tête légère, vertiges ou nausées. Si vous ressentez l'un de ces symptômes, vous devez consulter votre médecin avant de poursuivre votre programme d'exercice.
4. Tenez les enfants et les animaux domestiques éloignés de l'équipement. L'équipement est conçu pour une utilisation par des adultes uniquement.
5. Utilisez l'équipement sur une surface plane et solide, avec une protection pour votre sol ou votre tapis. Pour des raisons de sécurité, l'équipement doit avoir au moins 0,5 mètre d'espace libre tout autour.
6. Avant d'utiliser l'équipement, vérifiez que les écrous et les boulons sont bien serrés.
7. Le niveau de sécurité de l'équipement ne peut être maintenu que s'il est régulièrement examiné pour détecter les dommages et/ou l'usure.
8. Utilisez toujours l'équipement comme indiqué. Si vous trouvez des composants défectueux lors du montage ou de la vérification de l'équipement, ou si vous entendez un bruit inhabituel provenant de l'équipement pendant son utilisation, arrêtez-vous. N'utilisez pas l'équipement tant que le problème n'a pas été corrigé.
9. Portez des vêtements appropriés pendant l'utilisation de l'équipement. Évitez de porter des vêtements amples qui pourraient se prendre dans l'équipement ou qui pourraient restreindre ou empêcher les mouvements.
10. L'équipement n'est pas adapté à un usage thérapeutique.
11. Il faut veiller à ne pas se blesser le dos en soulevant ou en déplaçant l'équipement. Utilisez toujours les techniques de levage et/ou d'assistance appropriées.

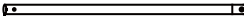
DESSIN D'ASSEMBLAGE EN VUE ÉCLATÉE

















PACKING DETAILS: TOTAL 2 BOXES

BOX-1/2

1  x 2	2  x 1	3  x 1	4  x 2
5  x 4	6  x 1	7  x 1	8  x 1
9  x 1	10  x 1	11  x 2	12  x 1
13  x 4	25  x 1	26  x 1	27  x 1
28  x 2	29  x 1	34  x 1	

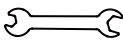
BOX-2/2

14  M10x150mm x 2	15  M10x70mm x 2	16  M10x65mm x 11	17  M10x60mm x 2	18  M6x30mm x 4
19  Sac de frappe M10 x 1	20  M10 x 32	21  M6 x 4	22  Écrou en nylon M10 x 16	23  M10 nut x 1
24  M6 x 4	30  x 1	31  x 2	32  x 1	33  x 1

DESSIN DE MONTAGE

Étape 1

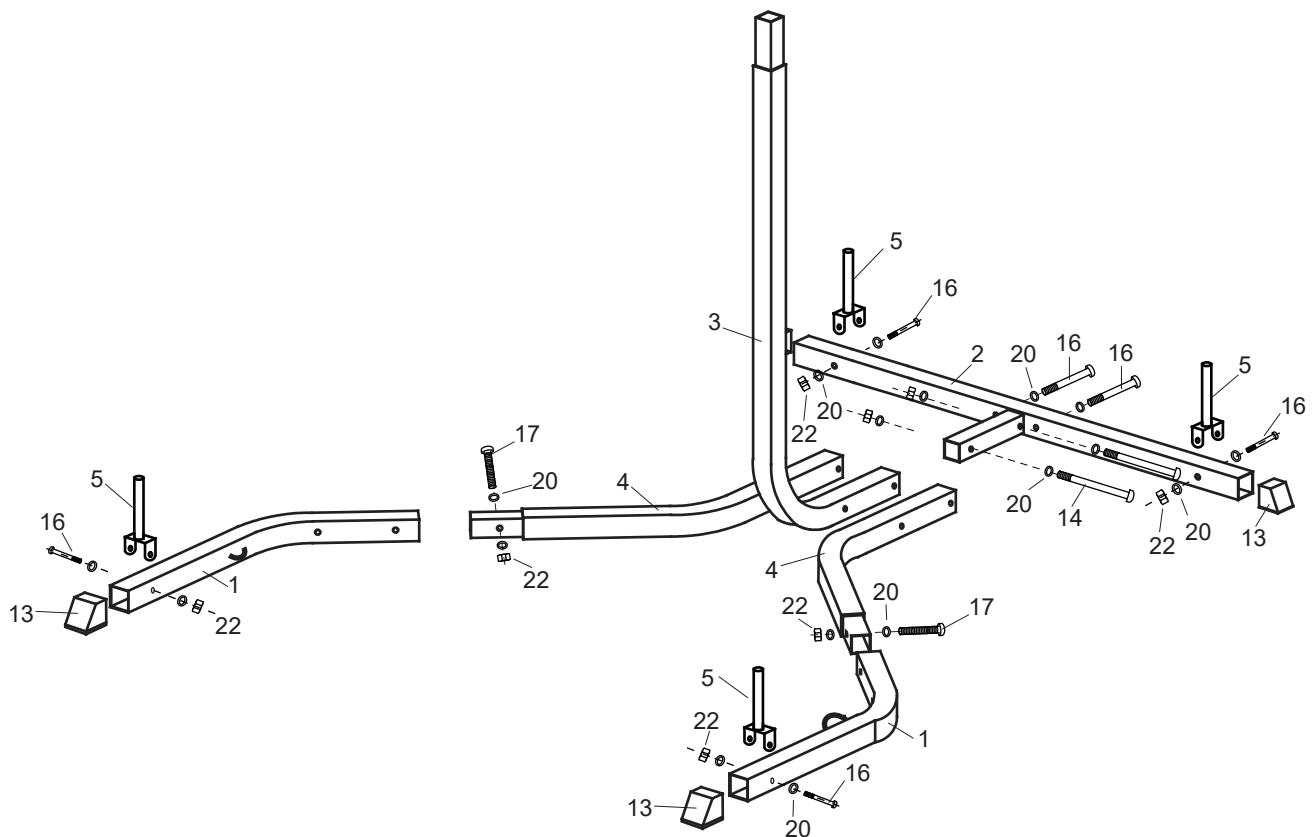

Montage du cadre de base

- 1) Montez l'embout de pied (13) sur le tube de base avant (1) et le tube de base arrière (2).
- 2) Vissez ensemble le tube de base (4) et le tube de base avant (1), en les fixant avec un boulon hexagonal M10x60 (17-2pcs), une rondelle M10 (20-4pcs) et un écrou en nylon M10 (22- 2pcs).
- 3) Vissez le tube de base (4) et le tube du pied inférieur (3) au tube de base arrière (2), fixé avec un boulon hexagonal M10x150 (14-2pcs), un boulon hexagonal M10x65 (16-2pcs), une rondelle M10 (20-6pcs) et un écrou en nylon M10 (22-2pcs).
- 4) Vissez le tube de la plaque de poids (5) au tube de base arrière (2) et au tube de base avant (1), fixé par un boulon hexagonal M10x65 (16-4pcs), une rondelle M10 (20-8pcs) et un écrou en nylon M10 (22-4pcs).

Étape 2

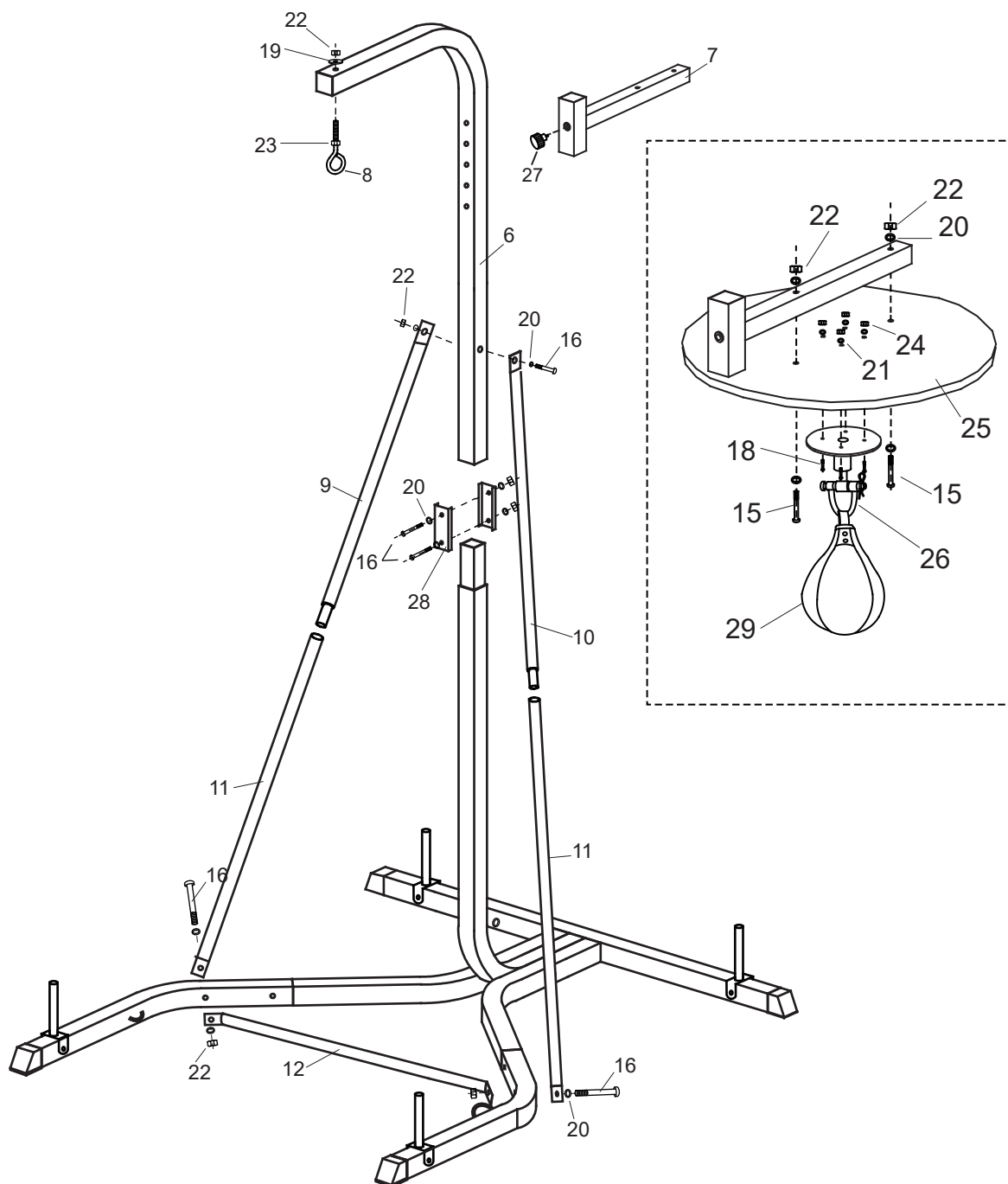

Montage du tube de support

1) Fixez le crochet de la balle de réflexe (26) et la plate-forme (25) au tube réglable (7), fixé avec un boulon M 10x 70 (15-2pcs), un boulon M6x 40 (18-4pcs), une rondelle M10 (20-4pcs), un écrou en nylon M10 (22-2pcs), une rondelle M6 (21-4pcs) et un écrou en nylon M6 (24-4pcs).

2) Insérez le tube réglable (7) dans le tube supérieur du support (6), verrouillé par la goupille rapide (27).

- 3) Vissez le tube supérieur du pied (6) au tube inférieur du pied (3), fixé par une plaque de support (28-2pcs), un boulon hexagonal M10x65 (16-2pcs), une rondelle M10 (20-4pcs) et un écrou en nylon M10 (22-2pcs).
- 4) Fixez le tube de renfort supérieur gauche (9) et le tube de renfort supérieur droit (10) au tube de renfort inférieur (11).
- 5) Vissez le tube de renfort au tube de base (1) et au tube supérieur du pied (6), en le fixant avec un boulon hexagonal M10x65 (16-3 pièces), une rondelle M10 (20-6 pièces) et un écrou en nylon M10 (22-3 pièces).
- 6) Vissez le crochet (8) au tube supérieur du support (6), fixé avec une rondelle M10 (19-1pc), un écrou en nylon M10 (22-1pc) et un écrou M10 (23-1pc).

INSTRUCTIONS D'EXERCICE

L'utilisation de l'équipement vous apportera plusieurs avantages, il améliorera votre condition physique, tonifiera vos muscles et, en conjonction avec un régime alimentaire à calories contrôlées, vous aidera à perdre du poids.

1. La phase d'échauffement

Cette étape permet de faire circuler le sang dans le corps et de faire fonctionner les muscles correctement. Elle réduit également le risque de crampes et de lésions musculaires. Il est conseillé de faire quelques exercices d'étirement comme indiqué ci-dessous. Chaque étirement doit être maintenu pendant environ 30 secondes. Ne forcez pas et ne secouez pas vos muscles pour les étirer - si vous avez mal, **ARRÊTEZ**.

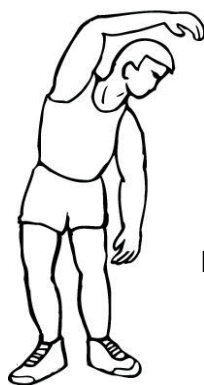

FLEXION LATÉRAL DU BUSTE



FLEXIONS EN AVANT



EXTÉRIEUR DES CUISSSES



INTÉRIEUR DES CUISSSES

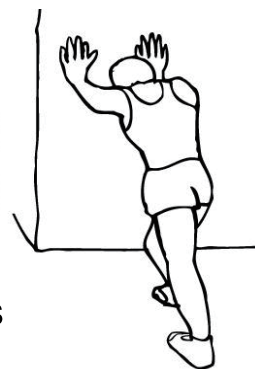

TALONS/ACHILLES

2. La phase de récupération

Cette étape consiste à laisser votre système cardio-vasculaire et vos muscles se détendre. Il s'agit d'une répétition de l'exercice d'échauffement, par exemple en réduisant votre rythme, puis en continuant pendant environ 5 minutes. Les exercices d'étirement doivent maintenant être répétés, en se rappelant encore une fois de ne pas forcer ou secouer vos muscles dans l'étirement.

Au fur et à mesure que vous vous améliorez, vous devrez peut-être vous entraîner plus longtemps et plus durement. Il est conseillé de s'entraîner au moins trois fois par semaine et, si possible, d'espacer vos séances d'entraînement de façon régulière tout au long de la semaine.

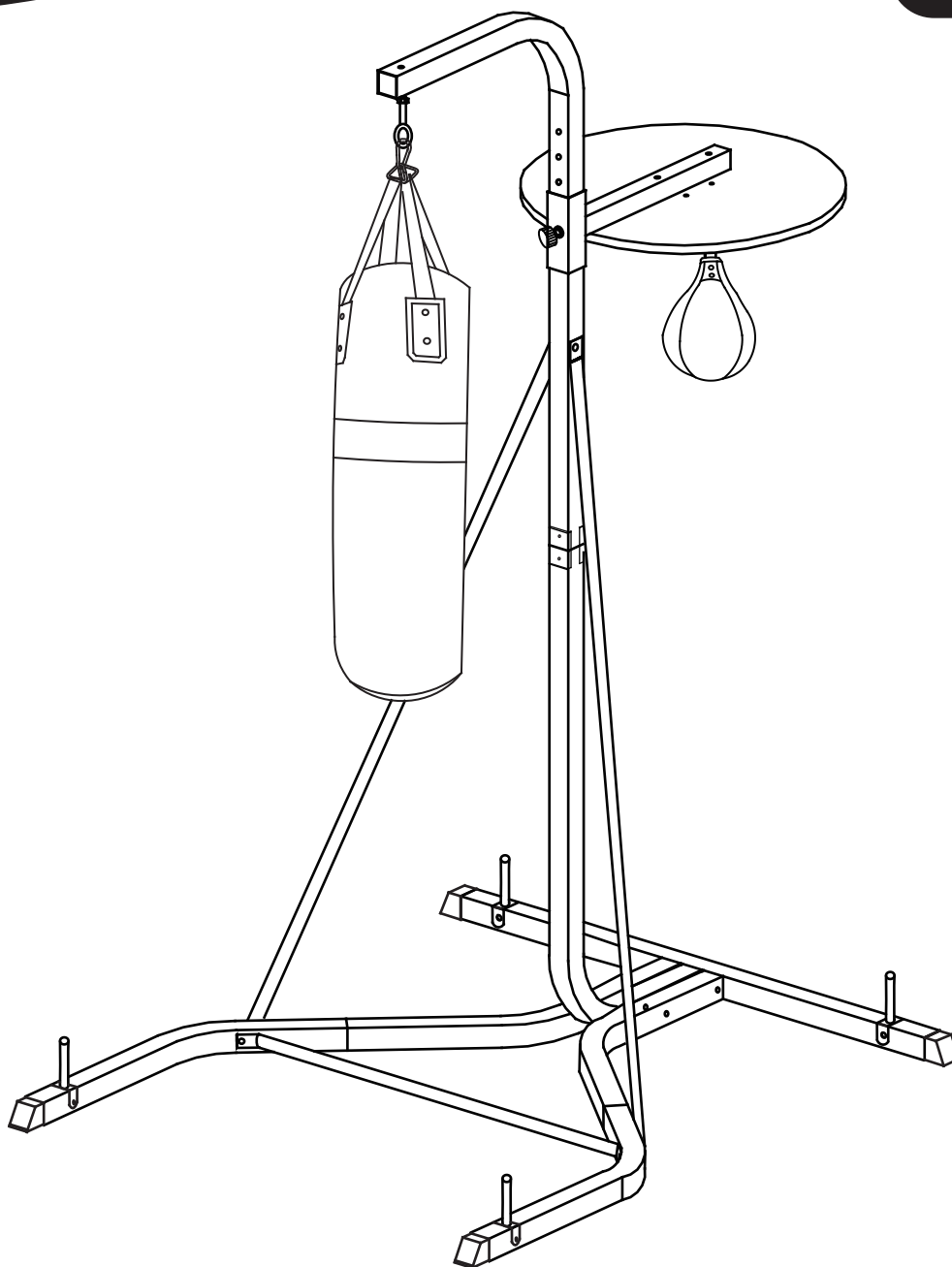

**IMPORTANTE, CONSERVAR PARA FUTURAS CONSULTAS: LEER
DETENIDAMENTE**

INSTRUCCIONES DE MONTAJE











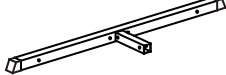



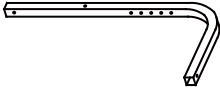
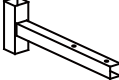

Información de Seguridad Importante

Guarde este manual bien para las futuras referencias.







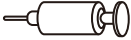





1. Es importante leer este manual por completo antes de montar y utilizar este equipo. El uso seguro y eficiente solo se puede lograr si el equipo se monta, se mantiene y se utiliza de manera correcta. Es su responsabilidad asegurarse de que todos los usuarios de este equipo estén informados de todas las advertencias y precauciones.
2. Antes de empezar cualquier entrenamiento de ejercicios, debe consultar a su médico para determinar si tiene alguna condición física o de salud que pueda provocar un riesgo para su salud y seguridad, o impedirle utilizar este equipo de manera correcta. El consejo de su médico es esencial si usted está tomando medicamentos que afectan su frecuencia cardíaca, presión arterial o nivel de colesterol.
3. Preste mucha atención de las señales de su cuerpo. El ejercicio incorrecto o inadecuado o excesivo puede dañar su salud. Deje de hacer ejercicio si experimenta alguno de los síntomas a continuación: Dolor, opresión en el pecho, latidos cardíacos irregulares, falta de aire extrema, desvanecimiento, mareos o náuseas. Si experimenta alguna de dichas condiciones, debe consultar a su médico antes de seguir su programa de entrenamiento de ejercicios.
4. Mantenga a los niños y las mascotas fuera de alcance del equipo. Este equipo solo está diseñado para el uso exclusivo de adultos.
5. Utilice este equipo sobre una superficie estable y plana con una cubierta protectora para el piso o la alfombra. Considerando la seguridad, el equipo debe tener al menos 0,5 metros de espacio libre a su alrededor.
6. Antes de utilizar este equipo, inspeccione si todas las tuercas y los tornillos estén apretados firmemente.
7. El nivel de seguridad de este equipo solo se puede mantener si usted lo examina de manera regular para detectar daños y / o desgastes.
8. Siempre utilice el equipo como lo que se indica en este manual. Si encuentra algún componente defectuoso durante realizar el montaje o verificar el equipo, o si escucha algún ruido anormal proveniente de este equipo al utilizarlo, deje de utilizarlo inmediatamente. No lo utilice hasta que se haya sido solucionado el problema.
9. Use ropa adecuada al utilizar este equipo. Evite usar ropa holgada que pueda quedar atrapada o que pueda restringir o prevenir hacer ejercicio.
10. El equipo no es adecuado para uso terapéutico.
11. Tenga mucho cuidado al levantar o desplazar el equipo por motivo de no lastimar su espalda.
Siempre utilice las técnicas apropiadas y/o pida ayuda con el fin de levantar objetos.

PACKING DETAILS: TOTAL 2 BOXES

BOX-1/2

1  x 2	2  x 1	3  x 1	4  x 2
5  x 4	6  x 1	7  x 1	8  x 1
9  x 1	10  x 1	11  x 2	12  x 1
13  x 4	25  x 1	26  x 1	27  x 1
28  x 2	29  x 1	34  x 1	

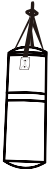
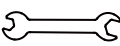
BOX-2/2

14  M10x150mm x 2	15  M10x70mm x 2	16  M10x65mm x 11	17  M10x60mm x 2	18  M6x30mm x 4
19  M10 Arandela gruesa x 1	20  M10 x 32	21  M6 x 4	22  M10 Tuerca de nailon x 16	23  M10 nut x 1
24  M6 x 4	30  x 1	31  x 2	32  x 1	33  x 1

PLANO DE MONTAJE

Paso 1

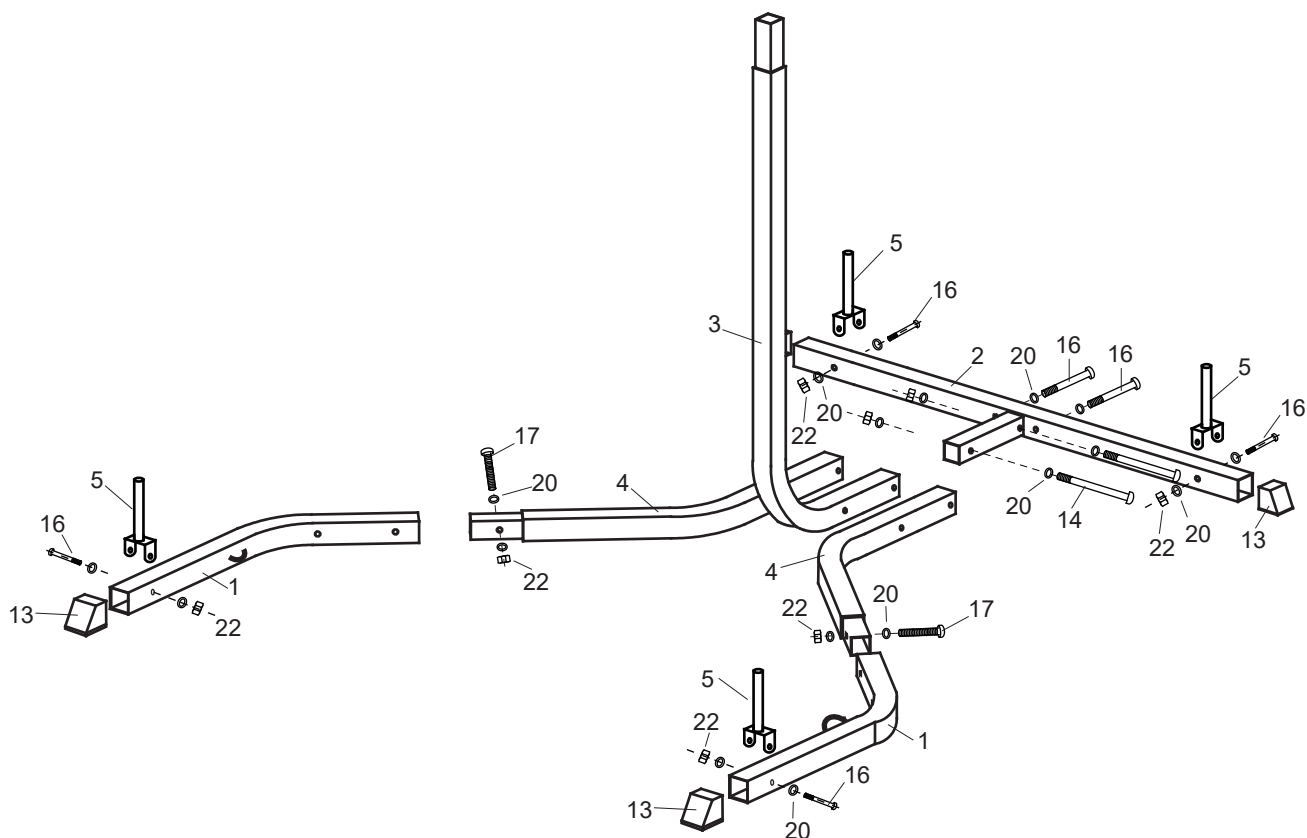

Montaje del marco base

(1) Inserte el tapón de pata (13) en el tubo de la base frontal (1) y el tubo de la base trasera (2).

(2) Fije el tubo de base (4) en el tubo base frontal (1) con un perno hexagonal M10x60 (17-2 piezas), una arandela M10 (20-4 piezas) y una tuerca de nylon M10 (22-2 piezas).

(3) Fije el tubo de base (4) y el tubo de soporte inferior (3) en el tubo de base trasero (2) con un perno hexagonal M10x150 (14-2 piezas), perno hexagonal M10x 65 (16-2 piezas), arandela M10 (20-6 piezas) y tuerca de nylon M10 (22-2 piezas).

(4) Fije el tubo de la placa de peso (5) al tubo de la base trasera (2) y al tubo de la base frontal (1) con un perno hexagonal M10x65 (16-4 piezas), una arandela M10 (20-8 piezas) y una tuerca de nylon M10 (22 piezas-4 piezas).

Paso 2

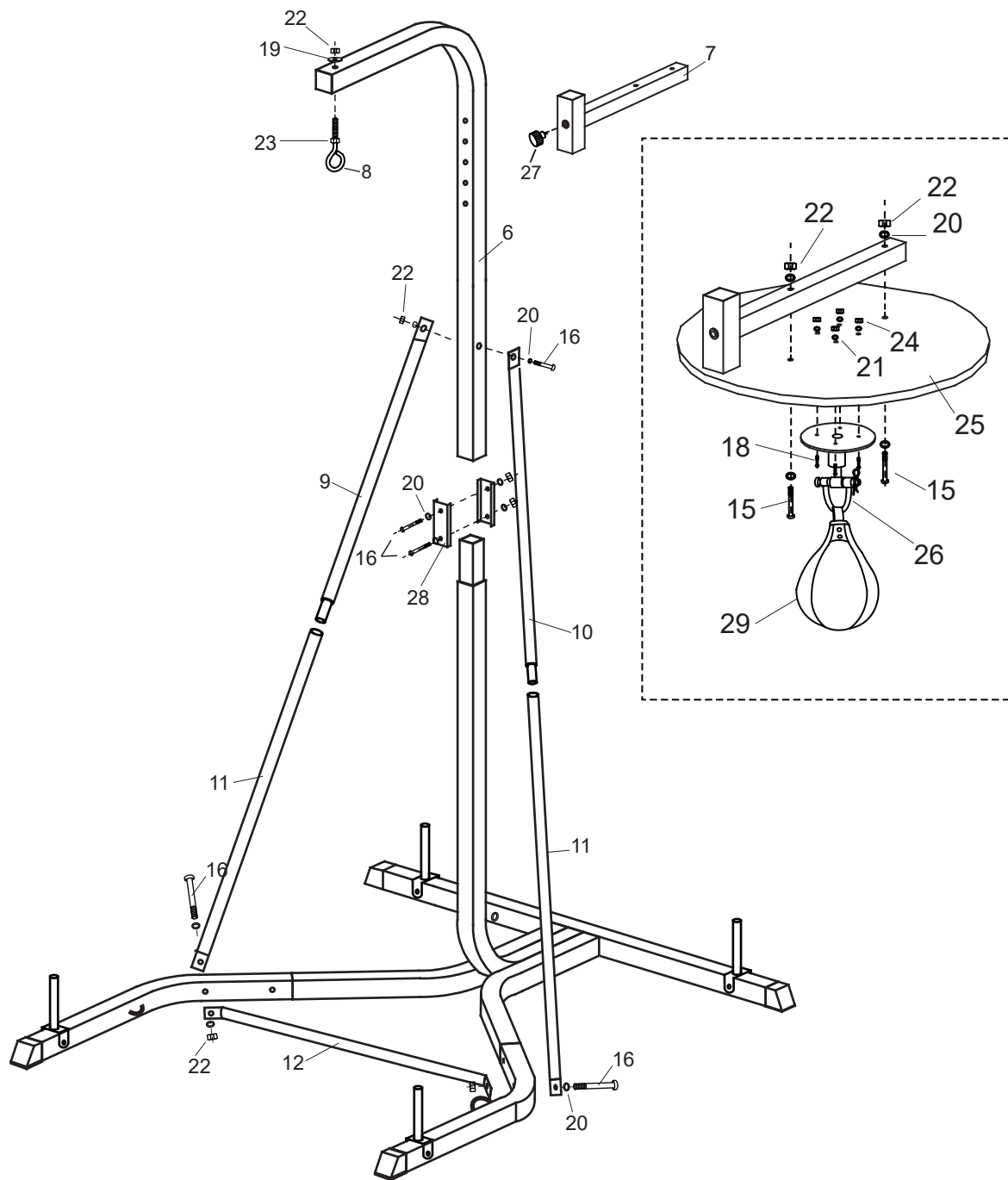

Montaje del tubo de soporte

1) Fije el gancho de bola de velocidad (26) y la plataforma (25) al tubo ajustable (7) con un perno M 10x 70 (15-2 piezas), un perno M6x 40 (18-4 piezas), una arandela M10 (20-4 piezas) , un tuerca de nylon M10 (22-2 piezas), arandela M6 (21-4 piezas) y tuerca de nylon M6 (24-4 piezas).

2) Inserte el tubo ajustable (7) en el tubo del soporte superior (6), blóqueelos con el pasador rápido (27).

- 3) Fije el tubo de soporte superior (6) al tubo de soporte inferior (3) con la placa de soporte (28-2 piezas), perno hexagonal M10x65 (16-2 piezas), arandela M10 (20-4 piezas) y tuerca de nailon M10 (22-2 piezas).
- 4) Conecte el tubo de sustento superior izquierdo (9) y el tubo de sustento superior derecho (10) al tubo de sustento inferior (11).
- 5) Fije el tubo de sustento al tubo de base (1) y al tubo de soporte superior (6) con un perno hexagonal M10x65 (16-3 piezas), una arandela M10 (20-6 piezas) y una tuerca de nailon M10 (22-3 piezas).
- 6) Fije el gancho (8) en el tubo del soporte superior (6) con una arandela M10 (19-1 pieza), una tuerca de nailon M10 (22-1 pieza) y una tuerca M10 (23-1 pieza).

INSTRUCCIONES DE EJERCICIO

Utilizar este equipo le brindará varios beneficios, mejorará su condición física, tonificará los músculos, y si toma una dieta controlada en calorías, le ayudará a perder peso.

1. Fase de calentamiento

Esta fase ayuda a que la sangre fluya por el cuerpo y a que los músculos funcionen de manera correcta. También reducirá el riesgo de calambres y lesiones musculares. Se recomienda hacer algunos ejercicios de estiramiento como lo que se muestra en la siguiente imagen. Cada estiramiento debe mantenerse durante 30 segundos más o menos, no fuerce ni sacuda los músculos en un estiramiento; si le duele, DETÉNGASE hacerlo inmediatamente.



2. Fase de relajación

Esta fase es para dejar que su sistema cardiovascular y sus músculos se relajen, p. Ej. se puede repetir el ejercicio de calentamiento para la fase de relajación, pero reduzca su ritmo, siga haciéndolo durante aproximadamente 5 minutos. Puede repetir los ejercicios de estiramiento ahora, recuerde no forzar ni sacudir los músculos en esta fase tampoco.

A medida que se pone en forma, deba entrenar más y más duro. Se recomienda entrenar al menos 3 veces por cada semana, y si es posible, espacie sus entrenamientos uniformemente a lo largo de la semana.

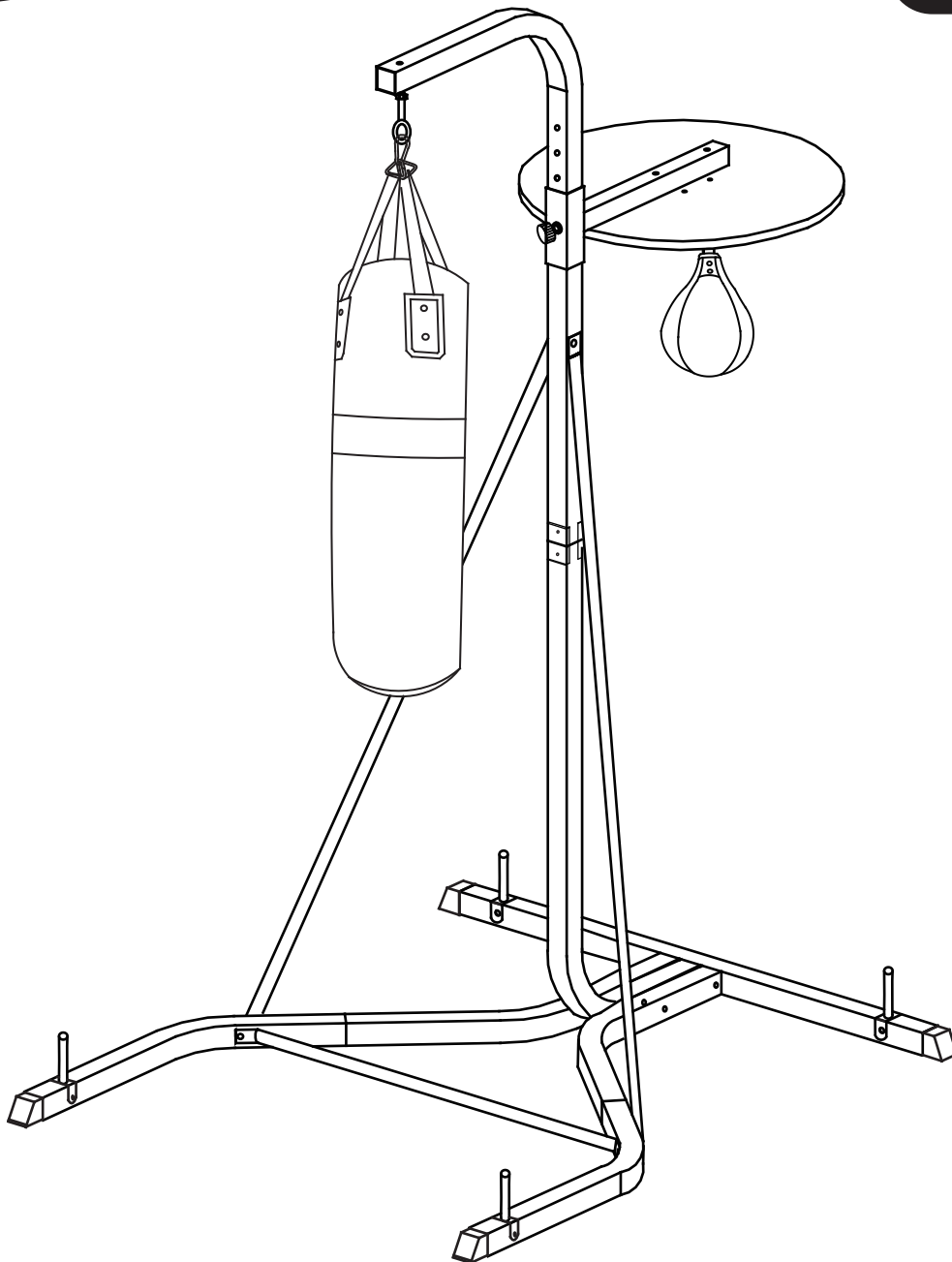

IMPORTANTE, RETER PARA REFERÊNCIA FUTURA: LEIA ATENTAMENTE

MANUAL DE INSTRUÇÕES

Informações Importantes de Segurança

Guarde bem este manual para referência futura.

1.É importante ler completamente este manual antes de montar e utilizar este equipamento.

A utilização segura e eficiente só pode ser alcançada se o equipamento for devidamente montado, mantido e operado. É da sua responsabilidade assegurar que todos os utilizadores deste equipamento sejam informados de todos os avisos e precauções.

2.Antes de iniciar qualquer treino de exercício, deve consultar o seu médico para determinar se tem algum problema físico ou de saúde que possa causar um risco para a sua saúde e segurança, ou impedi-lo de utilizar correctamente este equipamento. O conselho do seu médico é essencial se estiver a tomar medicamentos que afectam o seu ritmo cardíaco, pressão sanguínea ou nível de colesterol.

3.Preste muita atenção aos sinais do seu corpo. O exercício incorrecto, inadequado ou excessivo pode prejudicar a sua saúde. Pare de fazer exercício se sentir algum dos seguintes sintomas: dor, aperto no peito, batimento cardíaco irregular, falta de ar extrema, desmaios, tonturas ou náuseas. Se sofrer alguma destas condições, deve consultar o seu médico antes de continuar o seu programa de treino de exercício.

4.Manter as crianças e os animais de estimação fora do alcance do equipamento. Este equipamento destina-se apenas para uso adulto.

5.Utilizar este equipamento sobre uma superfície estável e plana com um revestimento protector do chão ou tapete. No interesse da segurança, o equipamento deve ter pelo menos 0,5 metros de espaço livre à sua volta.

6.Antes de utilizar este equipamento, verifique se todas as porcas e parafusos estão bem apertados.

7.O nível de segurança deste equipamento só pode ser mantido se o mesmo for inspeccionado regularmente quanto a danos e/ou desgaste.

8.Utilizar sempre o equipamento conforme as instruções deste manual. Se encontrar quaisquer componentes defeituosos durante a montagem ou verificação do equipamento, ou se ouvir qualquer ruído anormal proveniente deste equipamento quando o utilizar, pare imediatamente de o utilizar. Não utilizar o equipamento até que o problema tenha sido corrigido.

9.Usar roupa apropriada ao usar este equipamento. Evitar usar roupa solta que possa ficar presa ou que possa restringir ou impedir o exercício.

10.O equipamento não é adequado para uso terapêutico.





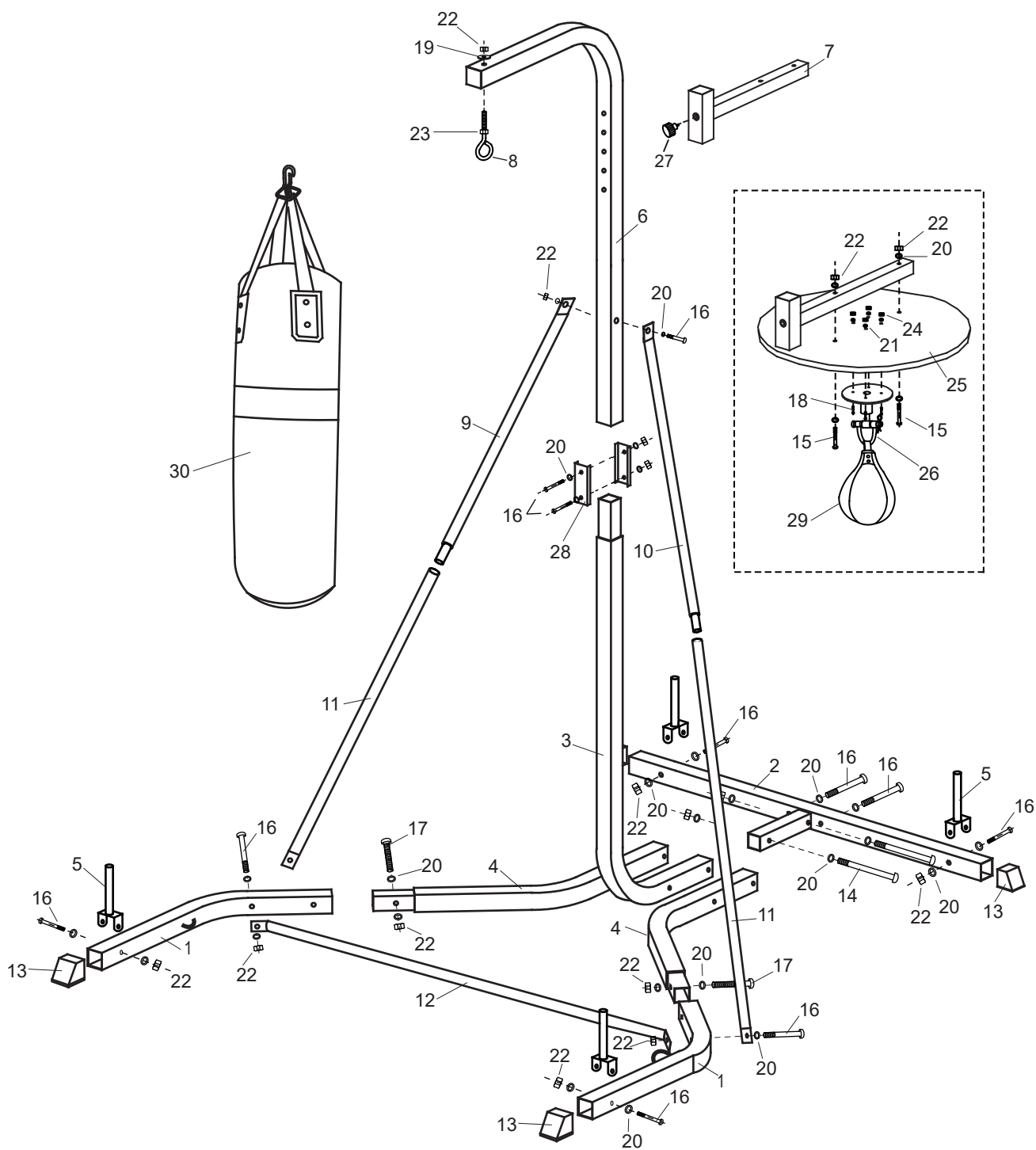





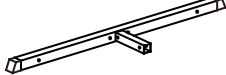



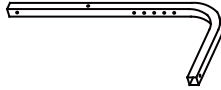
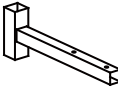

11.Usar de extremo cuidado ao levantar ou mover o equipamento de modo a não ferir as suas costas. Utilizar sempre técnicas adequadas e/ou pedir assistência para levantar objectos.

DESENHO DE MONTAGEM















PACKING DETAILS: TOTAL 2 BOXES

BOX-1/2

1  x 2	2  x 1	3  x 1	4  x 2
5  x 4	6  x 1	7  x 1	8  x 1
9  x 1	10  x 1	11  x 2	12  x 1
13  x 4	25  x 1	26  x 1	27  x 1
28  x 2	29  x 1	34  x 1	

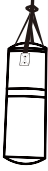
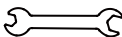
BOX-2/2

14  M10x150mm x 2	15  M10x70mm x 2	16  M10x65mm x 11	17  M10x60mm x 2	18  M6x30mm x 4
19  M10 Arruela gruesa x 1	20  M10 x 32	21  M6 x 4	22  M10 Porca de nylon x 16	23  M10 Porca x 1
24  M6 x 4	30  x 1	31  x 2	32  x 1	33  x 1

PLANO DE MONTAGEM

Passo 1

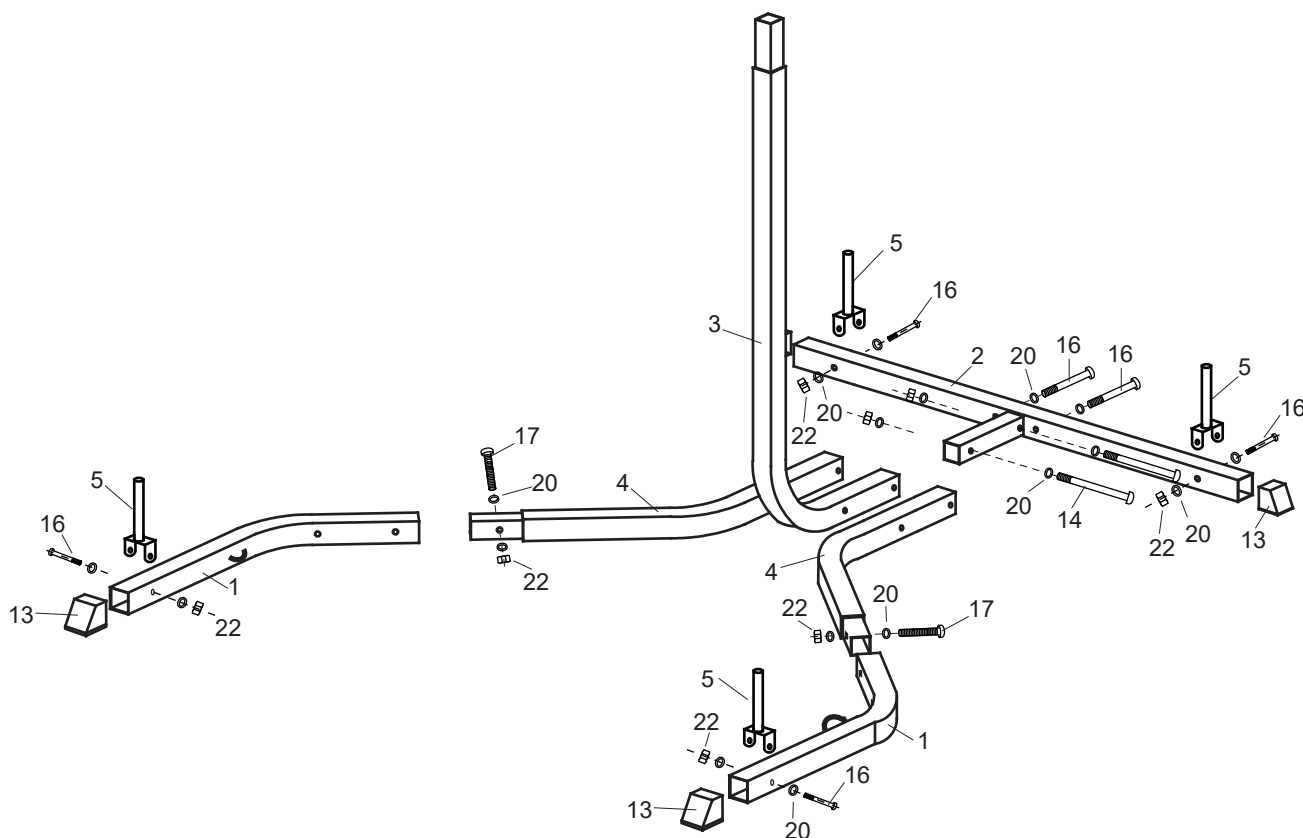

Montagem da estrutura de base

- (1) Inserir o tampão da perna (13) no tubo base dianteiro (1) e no tubo base traseiro (2).
- (2) Fixar o tubo base (4) ao tubo base dianteiro (1) com um parafuso hexagonal M10x60 (17-2 peças), uma arruela M10 (20-4 peças) e uma porca de nylon M10 (22-2 peças).
- (3) Fixar o tubo base (4) e o tubo suporte inferior (3) no tubo base traseiro (2) com um parafuso hexagonal M10x150 (14-2 pcs.), parafuso hexagonal M10x65 (16-2 pcs.), arruela M10 (20-6 pcs.) e porca de nylon M10 (22-2 pcs.).
- (4) Fixar o tubo da placa de peso (5) ao tubo da base traseira (2) e ao tubo da base dianteira (1) com um parafuso hexagonal M10x65 (16-4 pcs.), arruela M10 (20-8 pcs.) e porca de nylon M10 (22 pcs. -4 pcs.).

Passo 2

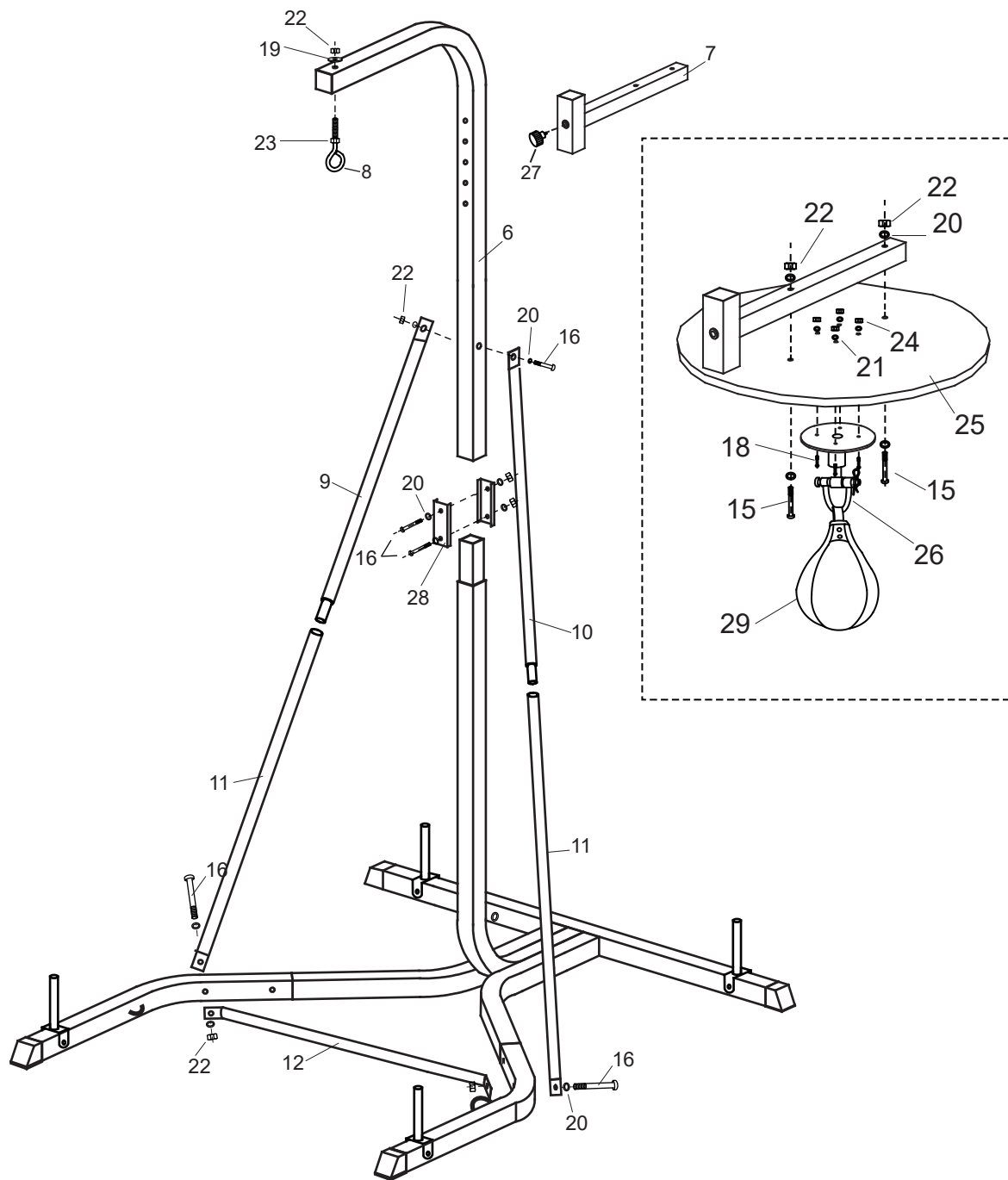

Montagem do tubo de suporte

- 1) Fixar o gancho da bola de velocidade (26) e a plataforma (25) ao tubo ajustável (7) com um parafuso M 10x 70 (15-2 pcs.), um parafuso M6x 40 (18-4 pcs.), uma arruela M10 (20-4 pcs.), porca de nylon M10 (22-2 pcs.), arruela M6 (21-4 pcs.) e porca de nylon M6 (24-4 pcs.).
- 2) Inserir o tubo ajustável (7) no tubo de suporte superior (6), fechá-los com o pino rápido (27).

- 3) Fixar o tubo de suporte superior (6) ao tubo de suporte inferior (3) com a placa de suporte (28-2 peças), parafuso hexagonal M10x65 (16-2 peças), arruela M10 (20-4 peças) e porca de nylon M10 (22-2 peças).
- 4) Ligar o tubo superior esquerdo de suporte (9) e o tubo superior direito de suporte (10) ao tubo inferior de suporte (11).
- 5) Fixar o tubo de suporte ao tubo base (1) e ao tubo de suporte superior (6) com parafuso hexagonal M10x65 (16-3 peças), arruela M10 (20-6 peças) e porca de nylon M10 (22-3 peças).
- 6) Fixar o gancho (8) no tubo de suporte superior (6) com uma arruela M10 (19-1 pcs.), uma porca de nylon M10 (22-1 pcs.) e uma porca M10 (23-1 pcs.).

INSTRUÇÕES DE EXERCÍCIOS

A utilização deste equipamento dar-lhe-á vários benefícios, melhorará a sua forma física, tonificará os seus músculos, e se estiver numa dieta com controlo calórico, ajudará a perder peso.

1. Fase de aquecimento

Esta fase ajuda o sangue a fluir através do corpo e ajuda os músculos a funcionar correctamente. Também irá reduzir o risco de câibras musculares e lesões. Recomenda-se a realização de alguns exercícios de alongamento, como se mostra na figura abaixo. Cada estiramento deve ser realizado durante cerca de 30 segundos, não forçar ou sacudir os músculos num estiramento; se doer, parar de o fazer imediatamente.



2. Fase de relaxação

Esta fase é para deixar o seu sistema cardiovascular e músculos relaxarem, ou seja, pode repetir o exercício de aquecimento para a fase de relaxamento, mas abrande o seu ritmo, continue a fazê-lo durante cerca de 5 minutos. Pode repetir os exercícios de alongamento agora, não se esqueça de não esticar ou de não mexer os músculos também nesta fase.

À medida que se vai ficando mais apto, deve treinar cada vez mais. Recomenda-se treinar pelo menos 3 vezes por semana, e se possível, espaçar os treinos uniformemente ao longo da semana.

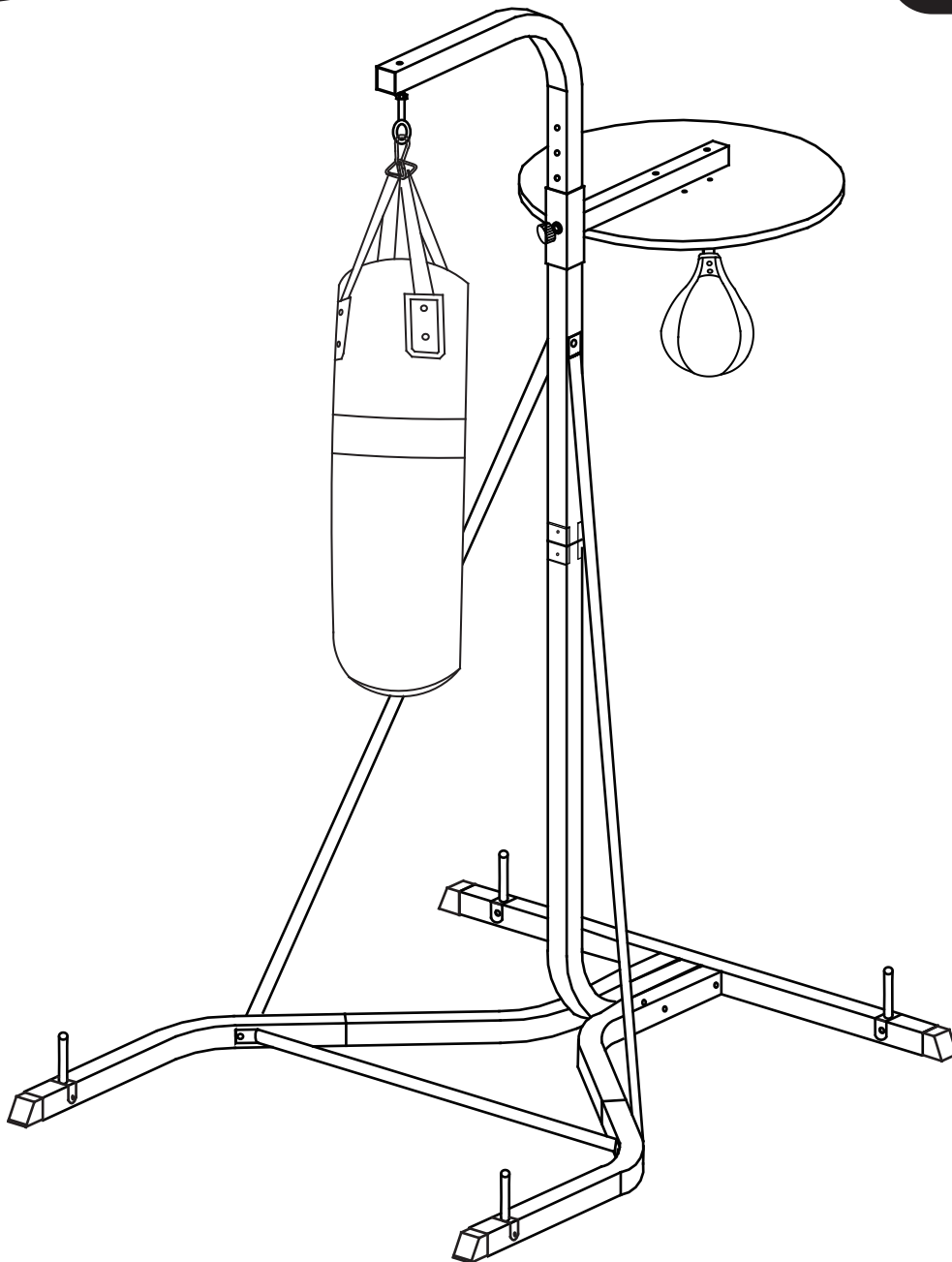

WICHTIG - BITTE HEBEN SIE DIESE ANLEITUNG FÜR
EINE SPÄTERE BEZUGNAHME AUF: SORGFÄLTIG DURCHLESEN

MONTAGEANLEITUNG

Wichtige Sicherheitsinformationen

Bitte bewahren Sie dieses Handbuch zum Nachschlagen an einem sicheren Ort auf.





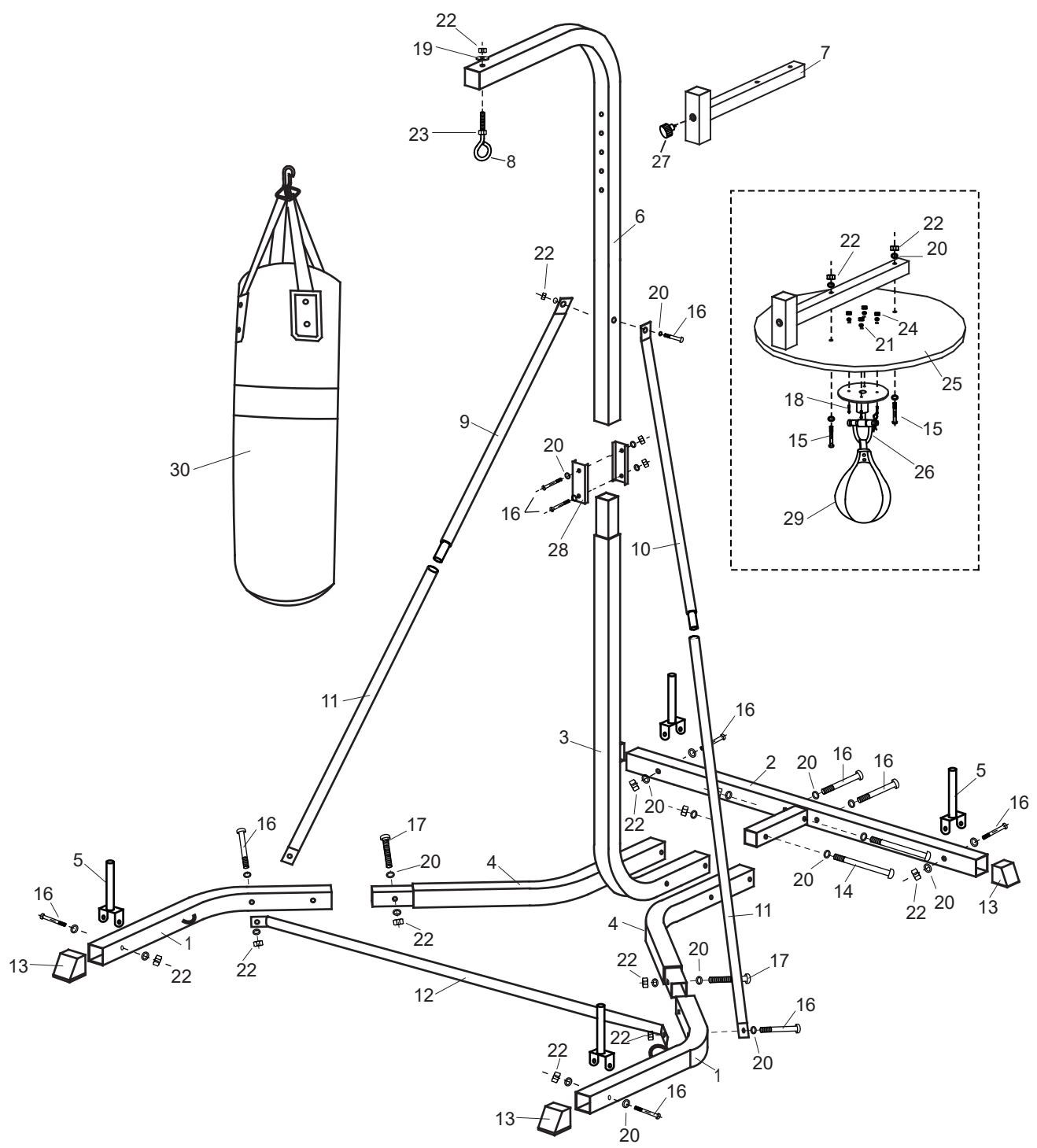





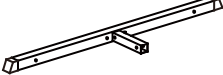



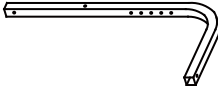
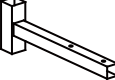

1. Es ist wichtig, dass Sie dieses Handbuch vor der Montage und der Inbetriebnahme des Geräts vollständig lesen.
Eine sichere und effiziente Verwendung kann nur erzielt werden, wenn das Gerät ordnungsgemäß montiert, gewartet und verwendet wird. Sie sind dafür verantwortlich, sicherzustellen, dass alle Anwender des Geräts über alle Warnhinweise und Vorsichtsmaßnahmen informiert sind.
2. Bevor Sie ein Trainingsprogramm beginnen, sollten Sie sich mit Ihrem Arzt beraten, um festzustellen, ob an körperlichen oder gesundheitlichen Beschwerden leiden, die ein Risiko für Ihre Gesundheit und Sicherheit darstellen oder Sie daran hindern könnten, das Gerät richtig anzuwenden. Der Rat Ihres Arztes ist unerlässlich, wenn Sie Medikamente einnehmen, die Ihre Herzfrequenz, Ihren Blutdruck oder Ihren Cholesterinspiegel beeinflussen.
3. Achten Sie auf Ihre Körpersignale. Falsches oder übermäßiges Training kann Ihre Gesundheit schädigen. Stellen Sie das Training ein, wenn Sie eines der folgenden Symptome verspüren: Schmerzen, Engegefühl in der Brust, unregelmäßiger Herzschlag, extreme Kurzatmigkeit, Benommenheit, Schwindel oder Übelkeit. Wenn Sie einem dieser Probleme leiden, sollten Sie sich mit Ihrem Arzt beraten, bevor Sie Ihr Trainingsprogramm fortsetzen.
4. Halten Sie Kinder und Haustiere von dem Gerät fern. Das Gerät ist ausschließlich für den Gebrauch durch Erwachsene vorgesehen.
5. Verwenden Sie das Gerät auf einer festen, ebenen Fläche mit einer Schutzabdeckung für Ihren Fußboden oder Teppich. Aus Sicherheitsgründen sollte um das Gerät herum ein Freiraum von mindestens 0,5 Metern vorhanden sein.
6. Prüfen Sie vor der Verwendung des Geräts, ob die Muttern und Schrauben fest angezogen sind.
7. Das Sicherheitsniveau des Geräts kann nur aufrechterhalten werden, wenn es regelmäßig auf Schäden und/oder Verschleiß überprüft wird.
8. Verwenden Sie das Gerät immer wie angegeben. Wenn Sie bei der Montage oder Überprüfung des Geräts defekte Komponenten feststellen oder während des Betriebs das Gerät ungewöhnliche Geräusche erzeugt, stellen Sie das Training ein. Verwenden Sie das Gerät erst wieder, sobald das Problem behoben wurde.
9. Tragen Sie bei der Verwendung des Geräts die geeignete Kleidung. Vermeiden Sie das Tragen loser Kleidung, das sich im Gerät verfangen oder die Bewegungen einschränken oder verhindern könnte.
10. Das Gerät ist nicht für die therapeutische Verwendung geeignet.
11. Seien Sie vorsichtig beim Anheben oder Bewegen des Geräts, um Rückenverletzungen zu vermeiden.
Wenden Sie stets die richtigen Hebetekniken und/oder nehmen Sie Hilfe in Anspruch.

MONTAGEZEICHNUNG MIT EXPLOSIONSDARSTELLUNG

















PACKING DETAILS: TOTAL 2 BOXES

BOX-1/2

1  x 2	2  x 1	3  x 1	4  x 2
5  x 4	6  x 1	7  x 1	8  x 1
9  x 1	10  x 1	11  x 2	12  x 1
13  x 4	25  x 1	26  x 1	27  x 1
28  x 2	29  x 1	34  x 1	

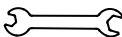
BOX-2/2

14  M10x150mm x 2	15  M10x70mm x 2	16  M10x65mm x 11	17  M10x60mm x 2	18  M6x30mm x 4
19  M10 dicker x 1	20  M10 x 32	21  M6 x 4	22  Nylonmutter M10 x 16	23  mutter M10 x 1
24  M6 x 4	30  x 1	31  x 2	32  x 1	33  x 1

MONTAGEZEICHNUNG

Schritt 1

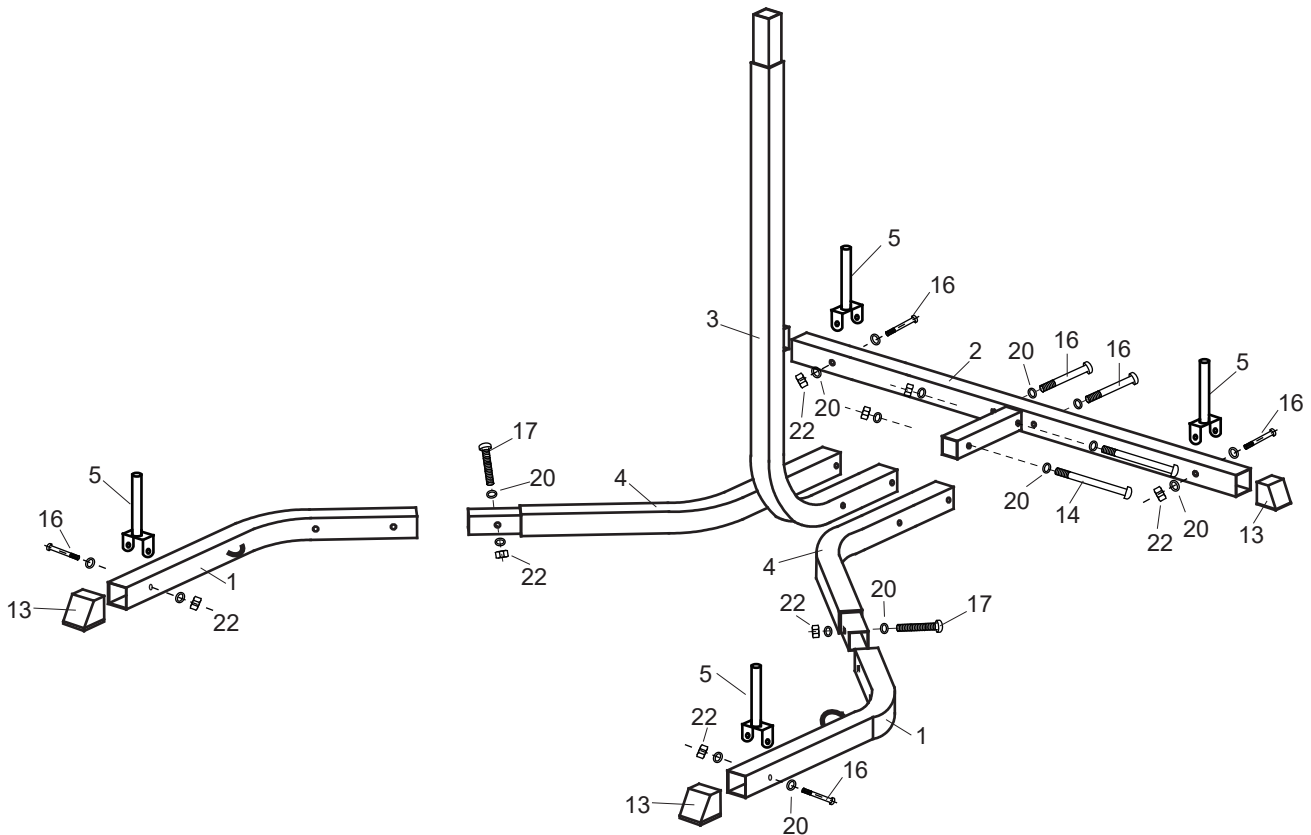

Montage des Grundrahmens

- (1) Montieren Sie die Fußkappe (13) an das vordere Grundrohr (1) und an das hintere Grundrohr (2).
- (2) Schrauben Sie das Grundrohr (4) und das vordere Grundrohr (1) zusammen, gesichert mit der Sechskantschraube M10x60 (17-2 Stck.), der Unterlegscheibe M10 (20-4 Stck.) und der Nylonmutter M10 (22- 2 Stck.).
- (3) Verschrauben Sie das Grundrohr (4) und das untere Stativrohr (3) mit dem hinteren Basisrohr (2), gesichert mit der Sechskantschraube M10x150 (14-2 Stck), der Sechskantschraube M10x 65 (16-2 Stck), der Unterlegscheibe M10 (20-6 Stck) und der Nylonmutter M10 (22-2 Stck).
- (4) Verschrauben Sie das Gewichtsplattenrohr (5) mit dem hinteren Grundrohr (2) und dem vorderen Grundrohr (1), gesichert mit der Sechskantschraube M10x65 (16-4 Stck), der Unterlegscheibe M10 (20-8 Stck) und der Nylonmutter M10 (22-4 Stck).

Schritt 2

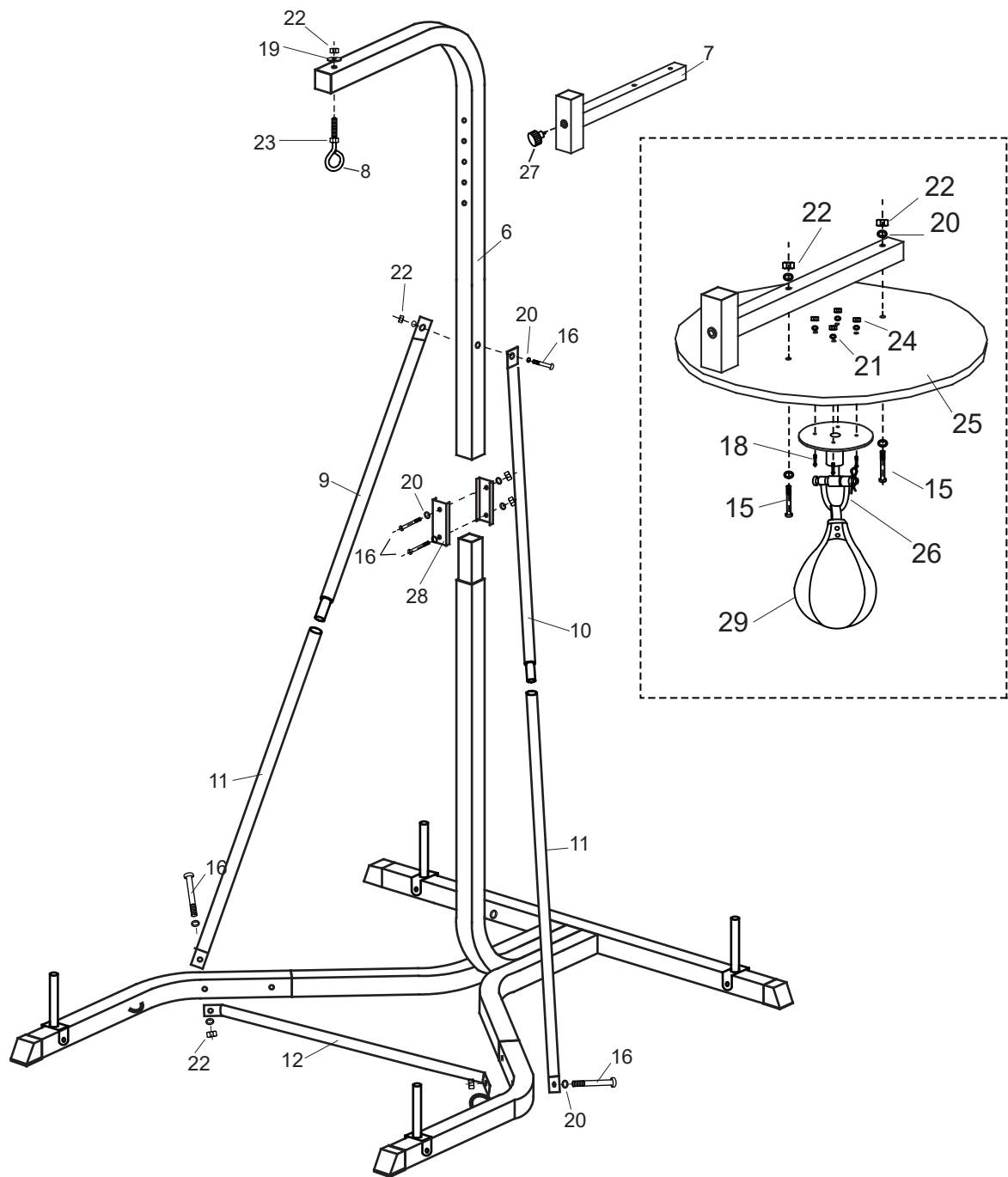

Montage des Stativrohrs

1) Befestigen Sie den Speedball-Haken (26) und die Plattform (25) am verstellbaren Rohr (7), gesichert mit der Schraube M 10x 70 (15-2 Stck), der Schraube M6x 40 (18-4 Stck), der Unterlegscheibe M10 (20-4 Stck), der Nylonmutter M10 (22-2 Stck), der Unterlegscheibe M6 (21-4 Stck) und der Nylonmutter M6 (24-4 Stck).

2) Montieren Sie das verstellbare Rohr (7) auf das obere Stativrohr (6), verriegelt mit dem Schnell-Pin (27).

- 3) Verschrauben Sie das obere Stativrohr (6) mit dem unteren Stativrohr (3), gesichert mit der Trägerplatte (28-2 Stck), der Sechskantschraube M10x65 (16-2 Stck), der Unterlegscheibe M10 (20-4 Stck) und der Nylonmutter M10 (22-2 Stck).
- 4) Befestigen Sie das obere linke Strebenrohr (9) und das obere rechte Strebenrohr (10) am unteren Strebenrohr (11).
- 5) Verschrauben Sie das Strebenrohr mit dem Grundrohr (1) und dem oberen Stativrohr (6), gesichert mit der Sechskantschraube M10x65 (16-3 Stck), der Unterlegscheibe M10 (20-6 Stck) und der Nylonmutter M10 (22-3 Stck).
- 6) Verschrauben Sie den Haken (8) mit dem oberen Stativrohr (6), gesichert mit der M10-Unterlegscheibe (19-1 Stck), der M10-Nylonmutter (22-1 Stck) und der M10-Mutter (23-1 Stck).

TRAININGSANLEITUNG

Die Verwendung des Geräts bietet Ihnen mehrere Vorteile, es verbessert Ihre körperliche Fitness, strafft die Muskeln und unterstützt Sie zusammen mit einer Kalorien-kontrollierten Diät beim Abnehmen.

1. Die Aufwärmphase

Diese Phase regt den Blutkreislauf an, sodass die Muskeln optimal reagieren. Außerdem verringert es das Risiko von Krämpfen und Muskelverletzungen. Es wird empfohlen, einige Streckübungen, wie unten dargestellt, auszuführen. Jede Dehnung sollte ca. 30 Sekunden lang gehalten werden. Erzwingen Sie nicht mit Gewalt oder ruckartig eine Dehnung der Muskeln - wenn Sie Schmerzen verspüren, UNTERBRECHEN Sie das Training.

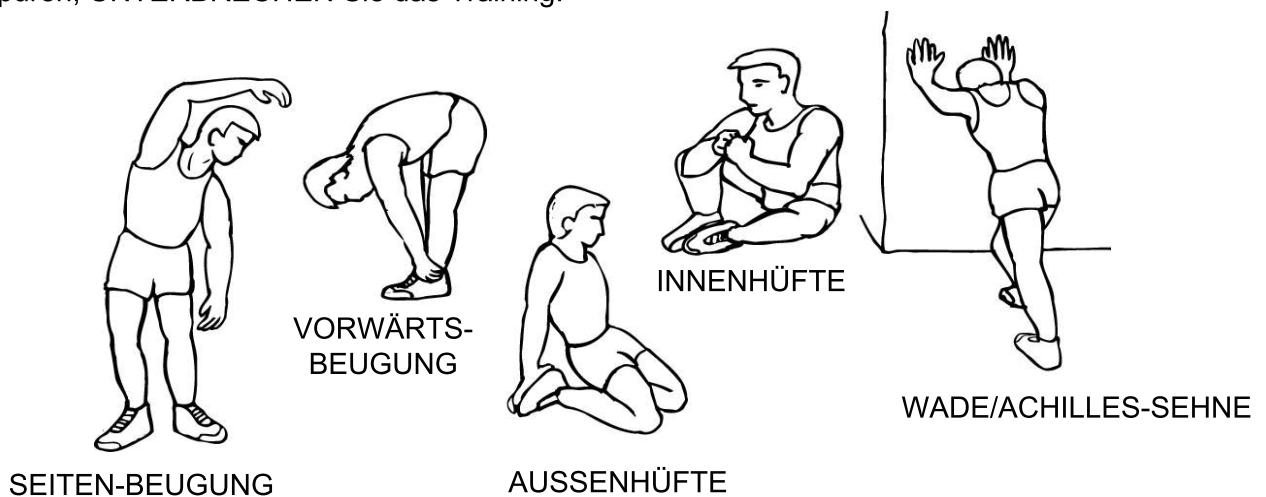

2. Die Abkühlphase

Der Zweck dieser Phase ist, Ihr Herz-Kreislauf-System und Ihre Muskeln zu entspannen. Es handelt sich hierbei um eine Wiederholung der Aufwärmübung, z.B. Tempo reduzieren, ca. 5 Minuten lang fortfahren. Wiederholen Sie nun die Streckübungen und beachten Sie, Ihre Muskeln nicht mit Gewalt oder ruckartig zu strecken.

Je fitter Sie werden, desto länger und härter müssen Sie möglicherweise trainieren. Es wird empfohlen, mindestens dreimal pro Woche zu trainieren, und wenn möglich, die Trainingseinheiten gleichmäßig über die Woche zu verteilen.

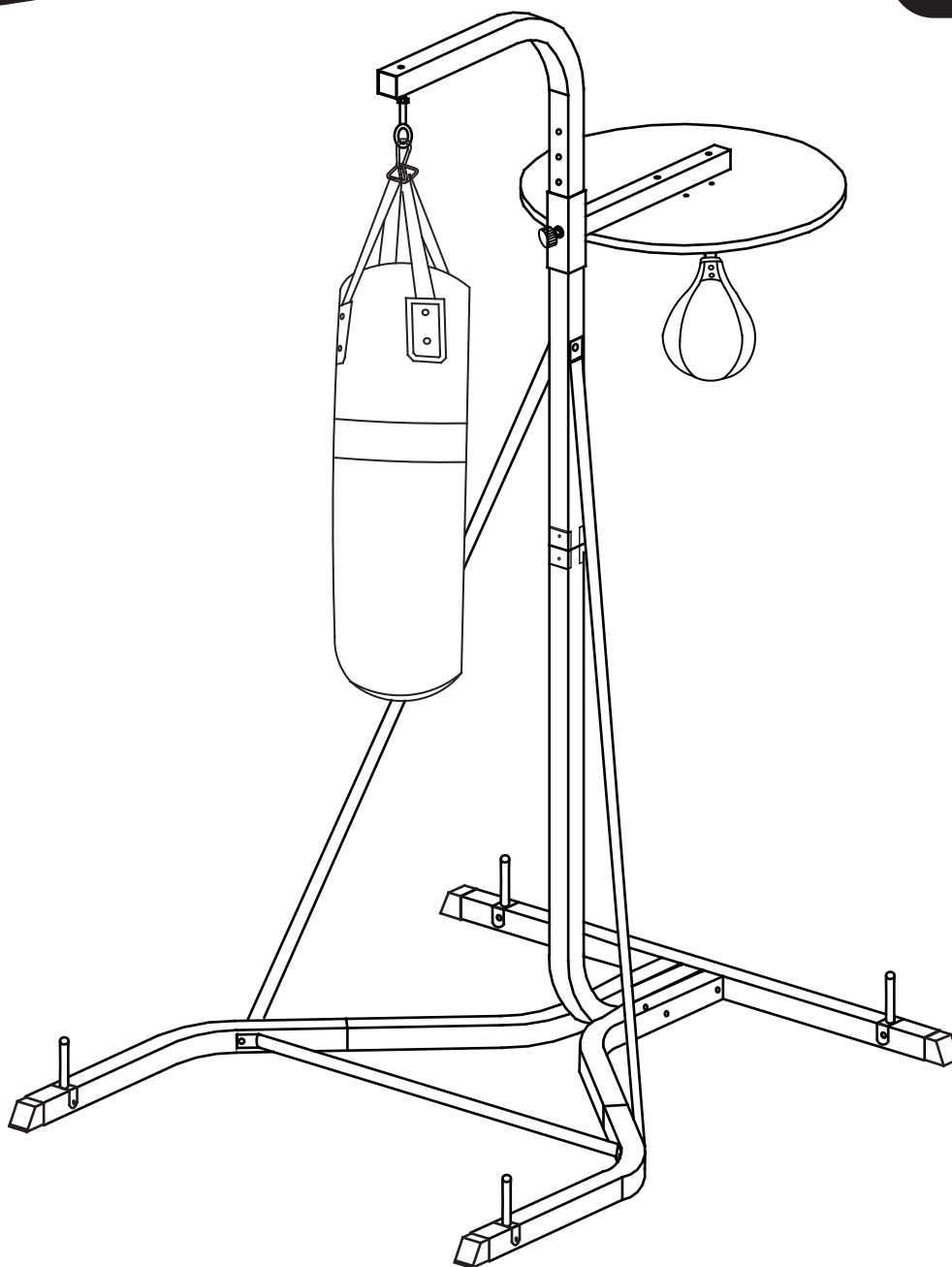

**IMPORTANTE - CONSERVARE QUESTE INFORMAZIONI
PER CONSULTARLE IN SEGUITO: LEGGERE ATTENTAMENTE**

ISTRUZIONI DI ASSEMBLAGGIO

Importanti informazioni di sicurezza

Conservare questo manuale in un luogo sicuro per riferimenti futuri.





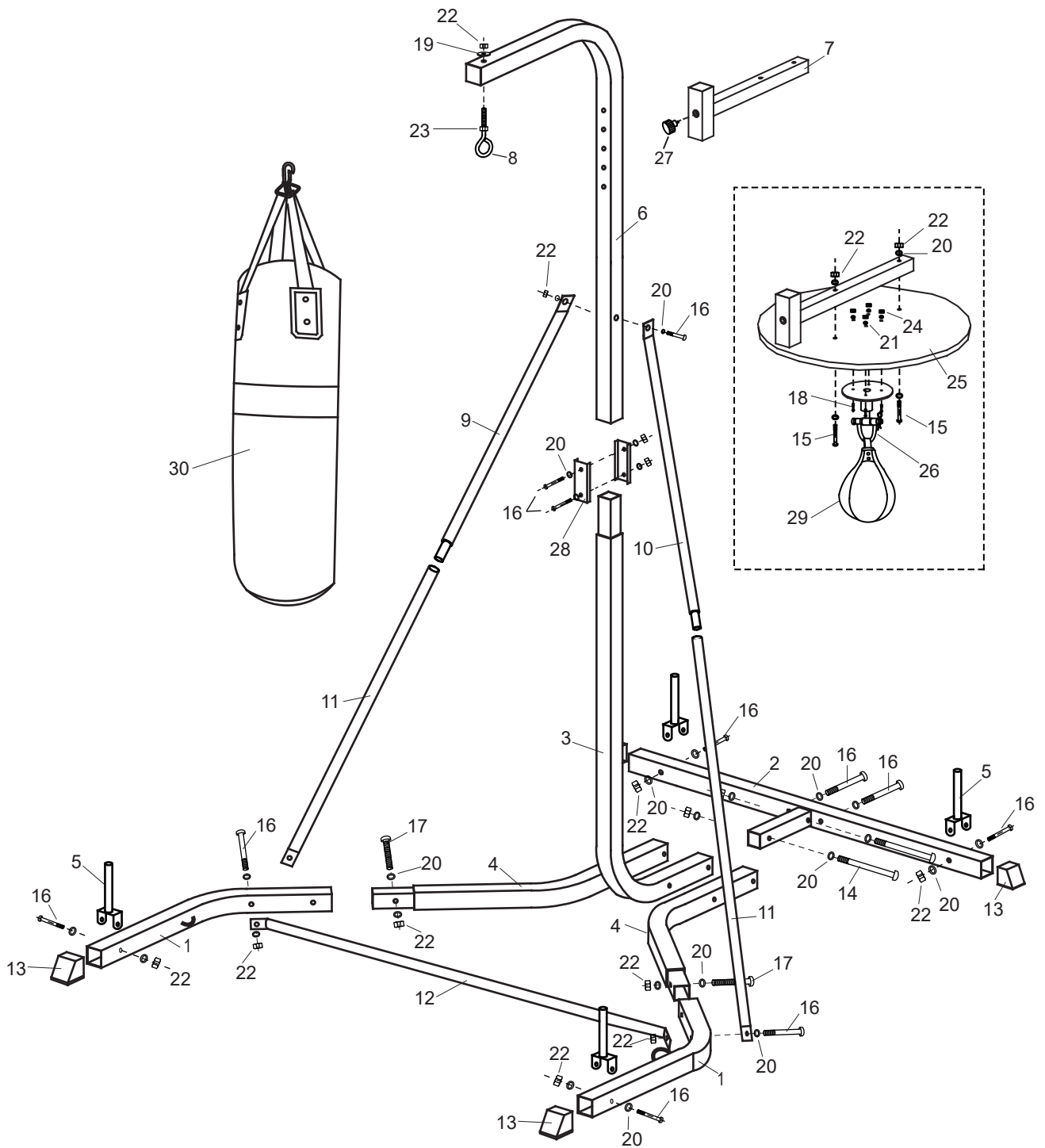





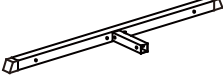



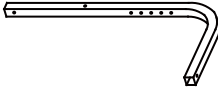
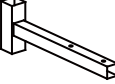

1. È importante leggere l'intero manuale prima di montare e utilizzare l'attrezzatura. Un utilizzo sicuro ed efficiente può essere effettuato solo se l'attrezzatura è assemblata, mantenuta e utilizzata correttamente. È vostra responsabilità assicurarsi che tutti gli utenti dell'attrezzatura siano informati delle avvertenze e precauzioni da seguire.
2. Prima di iniziare qualsiasi programma di allenamento, consultare il proprio medico per determinare se si hanno condizioni fisiche o di salute che potrebbero comportare un rischio per la vostra salute e la vostra sicurezza o impedire un uso corretto dell'attrezzatura. Il consiglio del medico è essenziale se si stanno assumendo farmaci che influenzano la frequenza cardiaca, la pressione sanguigna o il livello di colesterolo.
3. Siate consapevoli dei segnali del vostro corpo. Un esercizio scorretto o eccessivo può deteriorare la vostra salute. Interrompere l'esercizio se si rileva uno dei seguenti sintomi: dolore, senso di oppressione al petto, battito cardiaco irregolare, estrema mancanza di respiro, sensazione di testa leggera, vertigini o nausea. Se si verifica una di queste condizioni, consultare il medico prima di continuare con il programma di allenamento.
4. Tenere i bambini e gli animali domestici lontani dall'attrezzatura. L'attrezzatura è progettata solo per adulti.
5. Utilizzare l'attrezzatura su una superficie in piano e solida con una cover protettiva per il pavimento o la moquette. Per motivi di sicurezza, l'attrezzatura dovrebbe avere almeno 0,5 metri di spazio libero tutt'attorno.
6. Prima di utilizzare l'attrezzatura, controllare che i dadi e i bulloni siano ben stretti.
7. Il livello di sicurezza dell'attrezzatura può essere mantenuto solo se viene regolarmente esaminato per danni e / o usura.
8. Utilizzare sempre l'attrezzatura come indicato. Se si riscontrano componenti difettosi durante l'assemblaggio o il controllo delle parti, o se si sente un rumore insolito proveniente dall'attrezzatura durante l'uso, interrompere l'uso. Non utilizzare l'attrezzatura finché il problema non è stato risolto.
9. Indossare indumenti adatti durante l'utilizzo dell'attrezzatura. Evitare di indossare indumenti larghi che potrebbero rimanere impigliati nell'attrezzatura o che potrebbero limitare o impedire i vostri movimenti.
10. L'attrezzatura non è adatta per un uso terapeutico.
11. Prestare particolare attenzione quando si solleva o si sposta l'attrezzatura per non procurarsi lesioni alla schiena. Utilizzare sempre tecniche di sollevamento adeguate e / o chiedere assistenza.

VISTA ESPLOSA DIAGRAMMA DI ASSEMBLAGGIO



PACKING DETAILS: TOTAL 2 BOXES

BOX-1/2

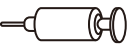
1  x 2	2  x 1	3  x 1	4  x 2	
5  x 4	6  x 1	7  x 1	8  x 1	
9  x 1	10  x 1	11  x 2	12  x 1	
13  x 4	25  x 1	26  x 1	27  x 1	28  x 2
29  x 1	34  x 1			

BOX-2/2















14  M10x150mm x 2	15  M10x70mm x 2	16  M10x65mm x 11	17  M10x60mm x 2	18  M6x30mm x 4
19  M10 più spesso x 1	20  M10 x 32	21  M6 x 4	22  M10 Dado in nylon x 16	23  M10 Dado x 1
24  M6 x 4	30  x 1	31  x 2	32  x 1	33  x 1

DIAGRAMMA DI ASSEMBLAGGIO

Passo 1

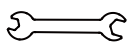

Assemblaggio del telaio base

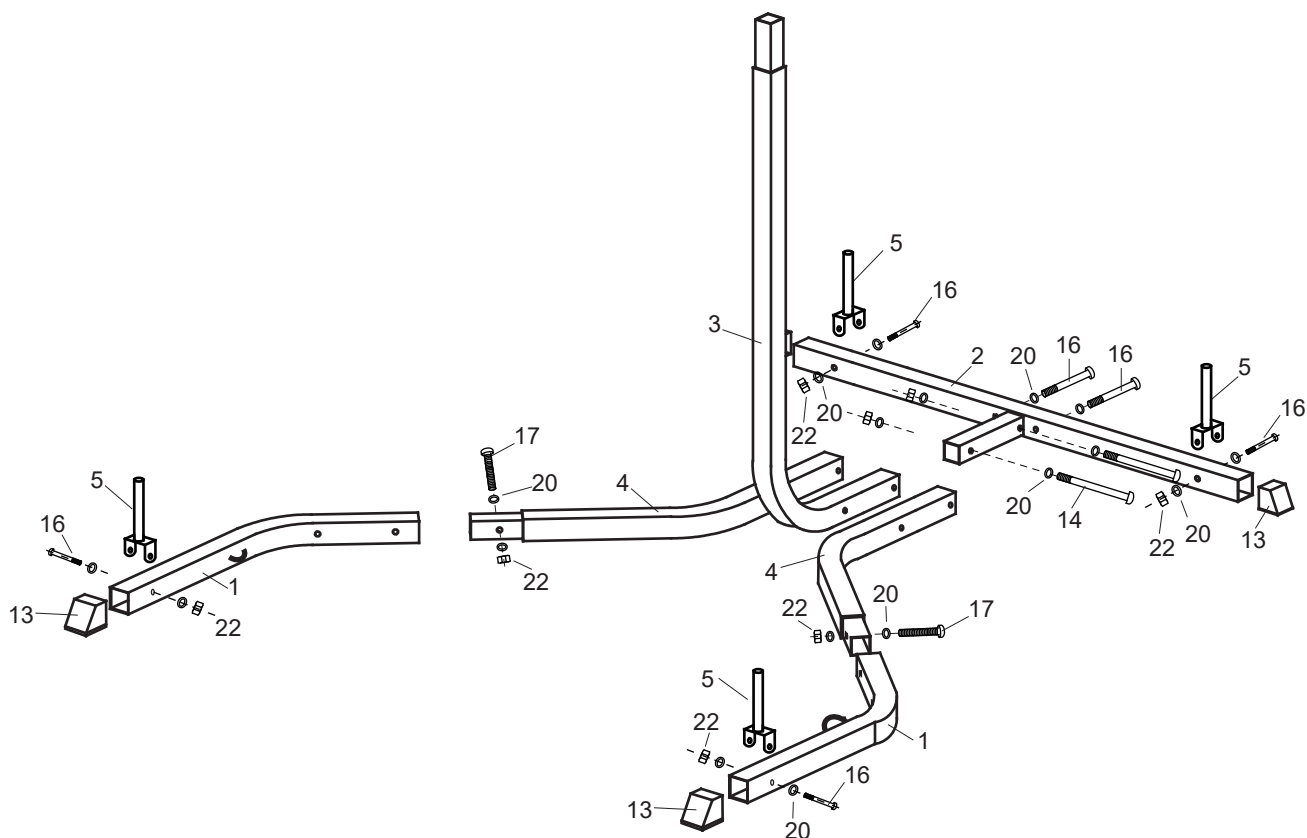
- (1) Montare la cover del piede (13) sul tubo base anteriore (1) e sul tubo base posteriore (2).
- (2) Collegare il tubo base (4) e il tubo base anteriore (1), fissare con bullone esagonale M10x60 (17-2 pezzi), rondella M10 (20-4 pezzi) e dado in nylon M10 (22-2 pezzi).
- (3) Collegare il tubo base (4) e il tubo di supporto inferiore (3) al tubo base posteriore (2), fissare con bullone esagonale M10x150 (14-2 pezzi), bullone esagonale M10x 65 (16-2 pezzi), rondella M10 (20-6 pezzi) e dado in nylon M10 (22-2 pezzi).
- (4) Collegare il tubo della piastra pesi (5) al tubo base posteriore (2) e al tubo base anteriore (1), fissare con bullone esagonale M10x65 (16-4 pezzi), rondella M10 (20-8 pezzi) e dado in nylon M10 (22-4 pezzi).

Passo 2

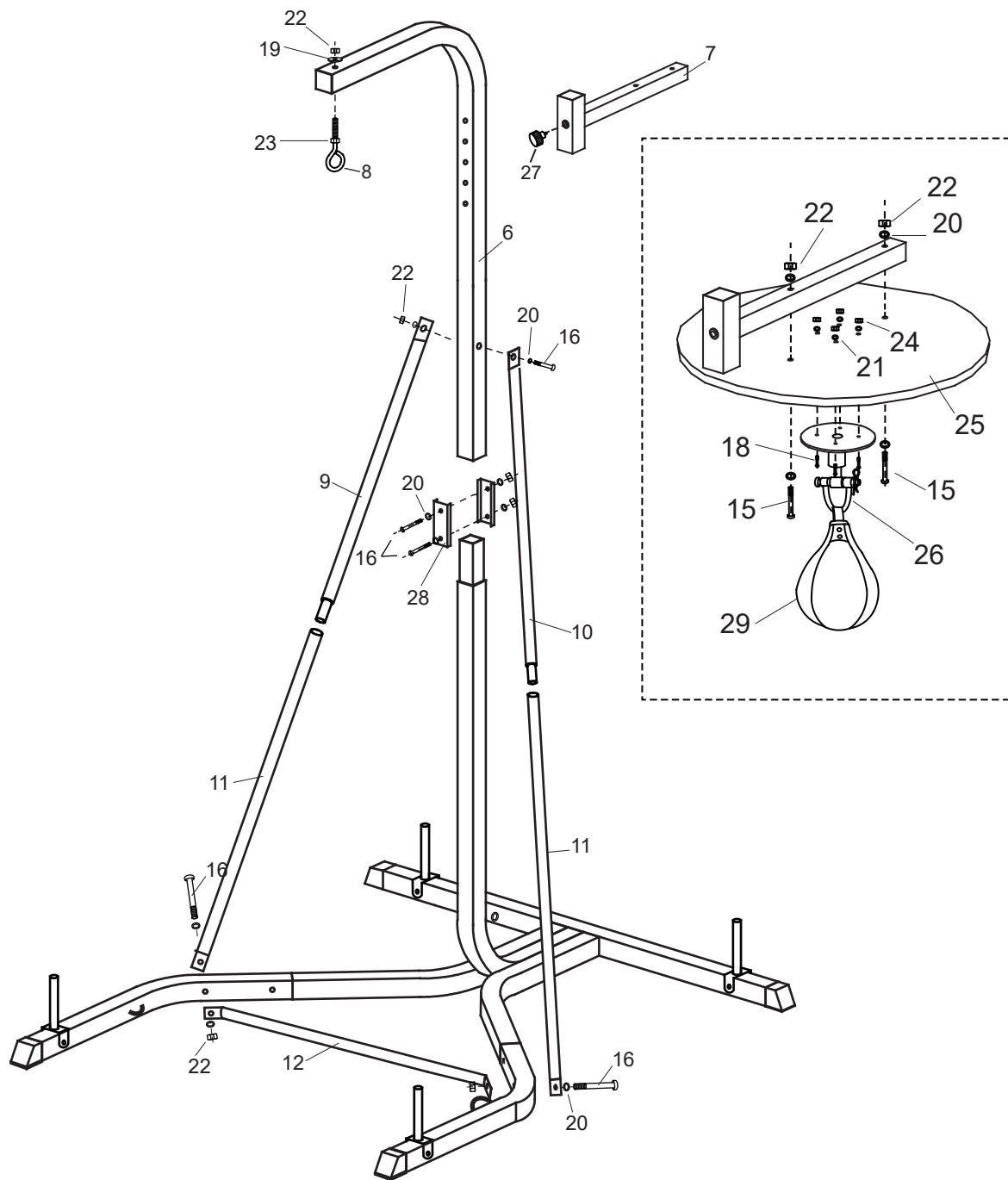

Assemblaggio del tubo verticale

1) Collegare il gancio Speed Ball (26) e la piastra (25) al tubo regolabile (7), fissare con bullone M 10x 70 (15-2 pezzi), bullone M6x 40 (18-4 pezzi), rondella M10 (20-4 pezzi), dado in nylon M10 (22-2 pezzi), rondella M6 (21-4 pezzi) e dado in nylon M6 (24-4 pezzi).

2) Inserire il tubo regolabile (7) nel tubo di supporto superiore (6), fissare con il perno a rilascio rapido (27).

- 3) Collegare il tubo di supporto superiore (6) al tubo di supporto inferiore (3), fissare con la piastra di supporto (28-2 pezzi), bullone esagonale M10x65 bullone esagonale (16-2 pezzi), rondella M10 (20-4 pezzi) e nylon M10 dado (22-2 pezzi).
- 4) fissare il tubo di supporto superiore sinistro (9) e il tubo di supporto superiore destro (10) al tubo di supporto inferiore (11).
- 5) Collegare il tubo di supporto al tubo di base (1) e al tubo di supporto superiore (6), fissare con bullone esagonale M10x65 (16-3 pezzi), rondella M10 (20-6 pezzi) e dado in nylon M10 (22-3 pezzi).
- 6) Collegare il gancio (8) al tubo di supporto superiore (6), fissato con rondella M10 (19-1 pz), dado M10 in nylon (22-1 pz) e dado M10 (23-1 pz).

ISTRUZIONI DI ALLENAMENTO

L'uso dell'attrezzatura vi fornirà numerosi vantaggi, migliorerà la vostra forma fisica, tonificherà i vostri muscoli e, in combinazione con una dieta a calorie controllate, vi aiuterà a perdere peso.

1. La fase di riscaldamento

Questa fase serve a far scorrere il sangue nel corpo e a far lavorare correttamente i muscoli. Ridurrà anche il rischio di crampi e lesioni muscolari durante l'allenamento. Si consiglia di eseguire alcuni esercizi di stretching come mostrato di seguito. Ogni posizione dovrebbe essere mantenuta per circa 30 secondi, non forzare o tirare i muscoli in fase di allungamento - se fa male, FERMARSI.

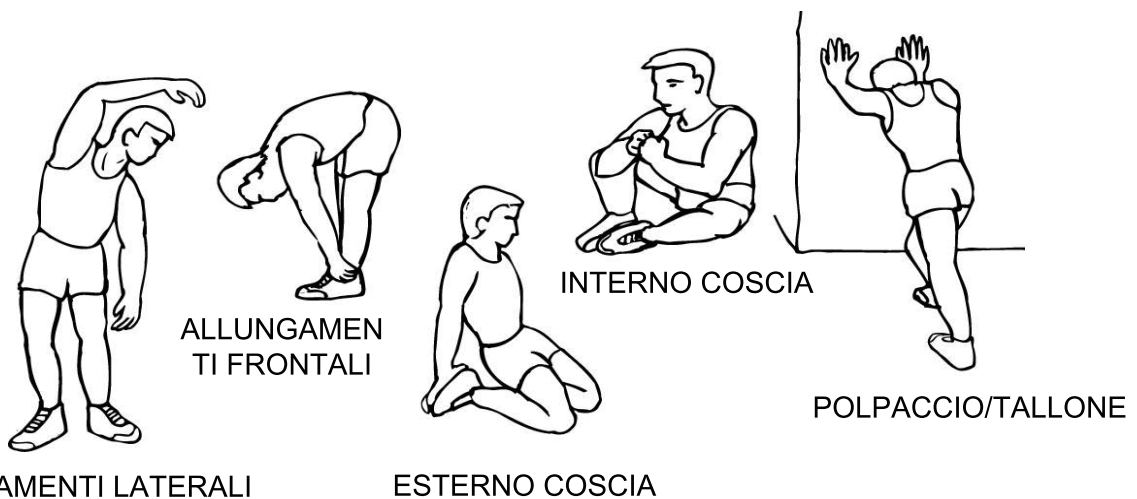

2. La fase di riposo

Questa fase serve a far rilassare il sistema cardio-vascolare e i muscoli. Questa fase è una ripetizione dell'esercizio di riscaldamento, ad es. riducendo il tempo, per circa 5 minuti. Gli esercizi di stretching vanno ripetuti, ricordando ancora di non forzare o scuotere i muscoli durante l'allungamento.

Man mano che migliorerete la vostra forma fisica potreste dovervi allenarti più a lungo e più duramente. Si consiglia di allenarsi almeno tre volte alla settimana e, se possibile, distanziare gli allenamenti in modo uniforme durante tutta la settimana.

If you have any questions, please contact our customer care center.

US

Our contact details are below:

 001-877-644-9366

 customerservice@aosom.com

Imported by Aosom LLC

7777 Center Ave. Suite 430

Huntington Beach, CA 92647-9998 USA

MADE IN CHINA

Si tiene alguna pregunta, comuníquese con nuestro Centro de Atención al Cliente.

ES

Nuestros datos de contacto son los siguientes:

 0034-931294512

 atencioncliente@aosom.es

Importador/Fabricante/REP:

Spanish Aosom, S.L.

C/ Roc Gros, nº 15. 08550, Els Hostalets de Balenyà, Spain.

B66295775

atencioncliente@aosom.es

TEL: 931294512

HECHO EN CHINA

If you have any questions, please contact our customer care center.

CA

Our contact details are below:

 416-792-6088

 customerservice@aosom.ca

Imported by Aosom Canada Inc.

7270 Woodbine Avenue, Unit 307, Markham,

Ontario Canada

L3R 4B9

MADE IN CHINA

Si vous avez la moindre question, veuillez contacter notre centre d'assistance à la clientèle.

Nos coordonnées sont les suivantes:

 416-792-6088

 customerservice@aosom.ca

Importé par Aosom Canada Inc.

7270 Woodbine Avenue, unité 307,

Markham, Ontario Canada

L3R 4B9

FABRIQUÉ EN CHINE

Se tiver alguma dúvida, por favor contacte o nosso Centro de Atendimento ao Cliente.

PT

Os nossos dados de contacto são os seguintes:

 0034-931294512 (SEG-SEX DAS 7:30H ÀS 16:30H)

 info@aosom.pt.

IMPORTADOR:

SPANISH AOSOM, S.L

C.ROC GROS N.15, 08550. ELS HOSTALETES DE BALENYÀ

WWW.AOSOM.PT

Wenn Sie Fragen haben, wenden Sie sich bitte an unser Kundendienstzentrum.

DE

Unsere Kontaktdaten stehen unten:

 0049-0(40)-87408465  service@aosom.de

Importeur/Hersteller/REP:

MH Handel GmbH

Wendenstraße 309

D-20537 Hamburg

Germany

IN CHINA HERGESTELLT

If you have any questions, please contact our customer care centre. Our contact details are below:

UK

 0044-800-240-4004

 enquiries@mhstar.co.uk

IMPORTER ADDRESS:

MH STAR UK Ltd

1 Northampton Cross Logistics Park

Northampton Cross Road

Northampton

NN4 9FH

Made in china

In caso di dubbio, si prega di contattare il nostro centro assistenza clienti.

IT

I nostri dettagli di contatto sono di seguito:

 0039-0249471447  clienti@aosom.it

IMPORTATO DA/Produttore/REP:

AOSOM Italy srl

Centro Direzionale Milanofiori

Strada 1 Palazzo F1

20057 Assago (MI)

P.I.: 08567220960

FATTO IN CINA

Si vous avez la moindre question, veuillez contacter notre centre d'assistance à la clientèle. Nos coordonnées sont les suivantes:

FR

 0033-1-84166106

 aosom@mhfrance.fr

Importé par/Fabricant/REP:

MH France

2, rue Maurice Hartmann

92130 Issy-les-Moulineaux

France

Fabriqué en Chine



FR

DONNEZ
OU
RECYCLEZ



ASSOCIATION

OU



LIVRAISON

OU



DÉCHÈTERIE

Adresses sur quefairedemesdechets.fr