

EN_IMPORTANT, RETAIN FOR FUTURE REFERENCE: READ CAREFULLY.

FR_IMPORTANT: A LIRE ATTENTIVEMENT ET A CONSERVER POUR VOUS Y REFERRER ULTERIEUREMENT

ES_IMPORTANTE, LEA DETENIDAMENTE Y GUARDE PARA FUTURAS REFERENCIAS.

PT_IMPORTANTE, GARDE PARA FUTURA REFERÊNCIA, LEIA ATENTAMENTE.

DE_WICHTIG! SORFGFÄLTIG LESEN UND FÜR SPÄTERES NACHSCHLAGEN AUFBEWAHREN.

IT_IMPORTANTE, LEGGERE E CONSERVARE QUESTO MANUALE D'ISTRUZIONE PER UN USO FUTURO.

RO_IMPORTANT, DE PĂSTRAT PENTRU REFERINȚE VIITOARE: CITIȚI CU ATENȚIE.

IMPORTANT, RETAIN FOR FUTURE REFERENCE: READ CAREFULLY.

General Safety

- Only for domestic use
- Maximum Load Capacity:
 - Chair: Maximum load 100 kg.
 - Table: Maximum load 50 kg.
- Not suitable for children under 3 years of age unless continuously supervised. Children aged 3-8 should only use this furniture under adult supervision.
- Children must not climb on the chairs or table. Climbing may cause the furniture to tip over, resulting in serious injury.
- Never stand on the chair seats or the table surface.
- Always place the furniture on a flat, dry, and stable floor. Uneven surfaces can compromise stability.

Assembly & Maintenance Warnings

- To ensure structural safety, check and tighten all screws, bolts, and fittings every 3 months. Loose joints can lead to instability.
- Do not modify the product structure or use non-original spare parts. Unauthorized modifications will void the warranty and may cause accidents.
- Keep packaging materials (plastic bags, foam) and small screws away from children to prevent suffocation or choking hazards.
- Do not place this furniture set near open flames, radiators, or other strong heat sources (e.g., electric heaters), as this may damage the materials or cause a fire hazard.
- Keep the furniture dry. Wipe up any spilled liquids immediately to prevent staining or material degradation.

Care & Maintenance

- Wipe clean with a soft, damp cloth. Dry immediately with a clean towel. Do not use abrasive cleaners, alcohol, or solvents.
- Avoid dragging the furniture across the floor. Lift it to move it to a new position. This protects both the furniture legs and your flooring.

IMPORTANT: A LIRE ATTENTIVEMENT ET À CONSERVER POUR CONSULTATION ULTÉRIEURE.

Sécurité générale

- Uniquement pour un usage domestique.
- Capacité de charge maximale :
 - Chaise : Charge maximale 100 kg.
 - Table : Charge maximale 50 kg.
- Ne convient pas aux enfants de moins de 3 ans, sauf s'ils sont sous surveillance continue. Les enfants âgés de 3 à 8 ans ne doivent utiliser ce mobilier que sous la surveillance d'un adulte.
- Les enfants ne doivent pas grimper sur les chaises ou la table. L'escalade peut faire basculer le mobilier et entraîner des blessures graves.
- Ne jamais se tenir debout sur l'assise des chaises ou sur la surface de la table.
- Toujours placer le mobilier sur un sol plat, sec et stable. Les surfaces inégales peuvent compromettre la stabilité.

Avertissements d'assemblage et d'entretien

- Pour assurer la sécurité structurelle, vérifiez et resserrez toutes les vis, tous les boulons et les raccords tous les 3 mois. Des joints desserrés peuvent entraîner une instabilité.
- Ne modifiez pas la structure du produit et n'utilisez pas de pièces de rechange non originales. Les modifications non autorisées annuleront la garantie et pourraient provoquer des accidents.
- Gardez les matériaux d'emballage (sacs en plastique, mousse) et les petites vis hors de portée des enfants pour éviter les risques d'étouffement ou d'ingestion.
- Ne placez pas cet ensemble de mobilier près de flammes nues, de radiateurs ou d'autres sources de chaleur intense (par exemple, des radiateurs électriques), car cela pourrait endommager les matériaux ou provoquer un risque d'incendie.
- Gardez le mobilier au sec. Essayez immédiatement tout liquide renversé pour éviter les taches ou la dégradation des matériaux.

Soins et entretien

- Nettoyez avec un chiffon doux et humide. Séchez immédiatement avec une serviette propre. N'utilisez pas de nettoyeurs abrasifs, d'alcool ou de solvants.
- Évitez de traîner le mobilier sur le sol. Soulevez-le pour le déplacer. Cela protège à la fois les pieds du mobilier et votre sol.

IMPORTANTE: LEA Y GUARDE PARA FUTURAS REFERENCIAS.

Seguridad general

- Solo para uso doméstico.
- Capacidad de carga máxima:
 - Silla: Carga máxima 100 kg.
 - Mesa: Carga máxima 50 kg.
- No apto para niños menores de 3 años, a menos que estén bajo supervisión continua. Los niños de 3 a 8 años solo deben usar este mobiliario bajo la supervisión de un adulto.
- Los niños no deben subirse a las sillas ni a la mesa. Subirse a los muebles puede hacer que se vuelquen y provocar lesiones graves.
- Nunca se pare sobre los asientos de las sillas ni sobre la superficie de la mesa.
- Coloque siempre los muebles sobre un suelo plano, seco y estable. Las superficies irregulares pueden comprometer la estabilidad.

Advertencias de montaje y mantenimiento

- Para garantizar la seguridad estructural, revise y apriete todos los tornillos, pernos y accesorios cada 3 meses. Las uniones flojas pueden provocar inestabilidad.
- No modifique la estructura del producto ni utilice piezas de repuesto no originales. Las modificaciones no autorizadas anularán la garantía y podrían provocar accidentes.
- Mantenga los materiales de embalaje (bolsas de plástico, espuma) y los tornillos pequeños fuera del alcance de los niños para evitar riesgos de asfixia o ingestión.
- No coloque este conjunto de muebles cerca de llamas abiertas, radiadores u otras fuentes de calor intensas (por ejemplo, calefactores eléctricos), ya que esto podría dañar los materiales o provocar un riesgo de incendio.
- Mantenga los muebles secos. Limpie inmediatamente cualquier líquido derramado para evitar manchas o la degradación del material.

Cuidado y mantenimiento

- Limpie con un paño suave y húmedo. Seque inmediatamente con una toalla limpia. No utilice limpiadores abrasivos, alcohol ni disolventes.
- Evite arrastrar los muebles por el suelo. Levántelos para moverlos a una nueva posición. Esto protege tanto las patas de los muebles como su suelo.

IMPORTANTE, RETER PARAREFERÊNCIA FUTURA: LEIA ATENTAMENTE.

Segurança geral

- Apenas para uso doméstico.
- Capacidade de carga máxima:
 - Cadeira: Carga máxima 100 kg.
 - Mesa: Carga máxima 50 kg.
- Não adequado para crianças com menos de 3 anos, a menos que sejam continuamente supervisionadas. Crianças dos 3 aos 8 anos só devem utilizar este mobiliário sob a supervisão de um adulto.
- As crianças não devem subir nas cadeiras ou na mesa. Subir nos móveis pode fazê-los tombar, resultando em ferimentos graves.
- Nunca fique em pé nos assentos das cadeiras ou na superfície da mesa.
- Coloque sempre os móveis num chão plano, seco e estável. Superfícies irregulares podem comprometer a estabilidade.

Avisos de montagem e manutenção

- Para garantir a segurança estrutural, verifique e aperte todos os parafusos, pernos e fixações a cada 3 meses. Juntas soltas podem levar à instabilidade.
- Não modifique a estrutura do produto nem utilize peças sobresselentes não originais. Modificações não autorizadas anularão a garantia e podem causar acidentes.
- Mantenha os materiais de embalagem (sacos de plástico, espuma) e os parafusos pequenos longe do alcance das crianças para evitar riscos de asfixia ou ingestão.
- Não coloque este conjunto de móveis perto de chamas abertas, radiadores ou outras fontes de calor fortes (por exemplo, aquecedores elétricos), pois isso pode danificar os materiais ou causar risco de incêndio.
- Mantenha os móveis secos. Limpe imediatamente qualquer líquido derramado para evitar manchas ou degradação do material.

Cuidados e manutenção

- Limpe com um pano macio e húmido. Seque imediatamente com uma toalha limpa. Não utilize produtos de limpeza abrasivos, álcool ou solventes.
- Evite arrastar os móveis pelo chão. Levante-os para os mover para uma nova posição. Isto protege tanto os pés dos móveis como o seu pavimento.

WICHTIG! SORGFÄLTIG LESEN UND ZUM SPÄTEREN NACHSCHLAGEN AUFBEWAHREN.

Allgemeine Sicherheit

- Nur für den Hausgebrauch.
- Maximale Tragfähigkeit:
 - Stuhl: Maximale Belastung 100 kg.
 - Tisch: Maximale Belastung 50 kg.
- Nicht geeignet für Kinder unter 3 Jahren, es sei denn, sie werden ständig beaufsichtigt. Kinder im Alter von 3 bis 8 Jahren dürfen diese Möbel nur unter Aufsicht von Erwachsenen benutzen.
- Kinder dürfen nicht auf den Stühlen oder dem Tisch klettern. Das Klettern kann zum Umkippen der Möbel führen und schwere Verletzungen verursachen.
- Stellen Sie sich niemals auf die Sitzflächen der Stühle oder die Tischplatte.
- Stellen Sie die Möbel immer auf einen ebenen, trockenen und stabilen Boden. Unebene Flächen können die Stabilität beeinträchtigen.

Warnungen zur Montage und Wartung

- Um die strukturelle Sicherheit zu gewährleisten, überprüfen und ziehen Sie alle Schrauben, Bolzen und Verbindungen alle 3 Monate fest. Lose Verbindungen können zu Instabilität führen.
- Nehmen Sie keine Änderungen an der Produktstruktur vor und verwenden Sie keine nicht originalen Ersatzteile. Nicht autorisierte Änderungen führen zum Erlöschen der Garantie und können Unfälle verursachen.
- Halten Sie Verpackungsmaterial (Plastiktüten, Schaumstoff) und kleine Schrauben von Kindern fern, um Erstickungs- oder Verschluckungsgefahren zu vermeiden.
- Stellen Sie dieses Möbelset nicht in die Nähe von offenem Feuer, Heizkörpern oder anderen starken Wärmequellen (z. B. elektrische Heizgeräte), da dies die Materialien beschädigen oder eine Brandgefahr verursachen kann.
- Halten Sie die Möbel trocken. Wischen Sie verschüttete Flüssigkeiten sofort auf, um Flecken oder Materialschäden zu vermeiden.

Pflege und Wartung

- Reinigen Sie die Oberflächen mit einem weichen, feuchten Tuch. Trocknen Sie sie sofort mit einem sauberen Handtuch ab. Verwenden Sie keine Scheuermittel, Alkohol oder Lösungsmittel.
- Vermeiden Sie es, die Möbel über den Boden zu ziehen. Heben Sie sie an, um sie an eine neue Position zu bringen. Dies schützt sowohl die Möbelfüße als auch Ihren Bodenbelag.

IMPORTANTE! CONSERVARE IL PRESENTE MANUALE PER FUTURO RIFERIMENTO E LEGGERLO ATTENTAMENTE.

Sicurezza generale

- Solo per uso domestico.
- Capacità di carico massima:
 - Sedia: Carico massimo 100 kg.
 - Tavolo: Carico massimo 50 kg.
- Non adatto a bambini di età inferiore ai 3 anni, a meno che non siano continuamente sorvegliati. I bambini di età compresa tra 3 e 8 anni dovrebbero utilizzare questi mobili solo sotto la supervisione di un adulto.
- I bambini non devono arrampicarsi sulle sedie o sul tavolo. Arrampicarsi può causare il ribaltamento dei mobili, provocando lesioni gravi.
- Non salire mai sulle sedute delle sedie o sul piano del tavolo.
- Posizionare sempre i mobili su un pavimento piano, asciutto e stabile. Le superfici irregolari possono compromettere la stabilità.

Avvertenze di montaggio e manutenzione

- Per garantire la sicurezza strutturale, controllare e serrare tutte le viti, i bulloni e i raccordi ogni 3 mesi. I giunti allentati possono portare a instabilità.
- Non modificare la struttura del prodotto o utilizzare parti di ricambio non originali. Le modifiche non autorizzate invalideranno la garanzia e potrebbero causare incidenti.
- Tenere i materiali di imballaggio (sacchetti di plastica, schiuma) e le viti piccole lontani dalla portata dei bambini per evitare rischi di soffocamento o ingestione.
- Non posizionare questo set di mobili vicino a fiamme libere, radiatori o altre forti fonti di calore (ad esempio, stufe elettriche), poiché ciò potrebbe danneggiare i materiali o causare un rischio di incendio.
- Tenere i mobili asciutti. Pulire immediatamente eventuali liquidi versati per evitare macchie o il degrado del materiale.

Cura e manutenzione

- Pulire con un panno morbido e umido. Asciugare immediatamente con un asciugamano pulito. Non utilizzare detergenti abrasivi, alcol o solventi.
- Evitare di trascinare i mobili sul pavimento. Sollevarli per spostarli in una nuova posizione. Questo protegge sia le gambe dei mobili che il pavimento.

IMPORTANT, PĂSTRAȚI PENTRU REFERINȚE VIITOARE: CITIȚI CU ATENȚIE.

Siguranță generală

- Doar pentru uz casnic.
- Capacitatea maximă de încărcare:
Scaun: Sarcină maximă 100 kg.
Masă: Sarcină maximă 50 kg.
- Nu este potrivit pentru copii cu vârsta sub 3 ani, cu excepția cazului în care sunt supravegheați continuu. Copiii cu vârsta cuprinsă între 3 și 8 ani ar trebui să utilizeze aceste mobilă doar sub supravegherea unui adult.
- Copiii nu trebuie să se cațere pe scaune sau pe masă. Cățărarea poate face ca mobilierul să se răstoarne, provocând răni grave.
- Nu stați niciodată în picioare pe șezuturile scaunelor sau pe suprafața mesei.
- Așezați întotdeauna mobilierul pe o podea plană, uscată și stabilă. Suprafețele inegale pot compromite stabilitatea.







Avertismente de asamblare și întreținere

- Pentru a asigura siguranța structurală, verificați și strângeți toate șuruburile, buloanele și îmbinările la fiecare 3 luni. Îmbinările slăbite pot duce la instabilitate.
- Nu modificați structura produsului și nu utilizați piese de schimb care nu sunt originale. Modificările neautorizate vor anula garanția și pot provoca accidente.
- Țineți materialele de ambalare (pungi de plastic, spumă) și șuruburile mici departe de copii pentru a preveni riscurile de sufocare sau înghițire.
- Nu așezați acest set de mobilă în apropierea flăcărilor deschise, a radiatoarelor sau a altor surse puternice de căldură (de exemplu, încălzitoare electrice), deoarece acest lucru poate deteriora materialele sau poate provoca un risc de incendiu.
- Păstrați mobilierul uscat. Ștergeți imediat orice lichid vărsat pentru a preveni petele sau degradarea materialului.

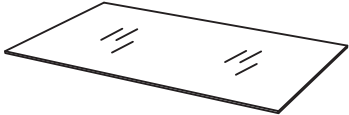
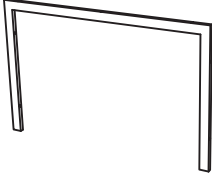

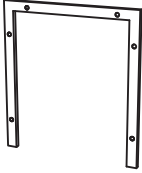

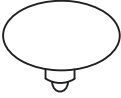

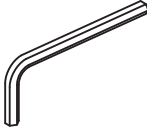
Îngrijire și întreținere

- Curățați cu o cârpă moale și umedă. Uscați imediat cu un prosop curat. Nu utilizați agenți de curățare abrazivi, alcool sau solvenți.
- Evitați târârea mobilierului pe podea. Ridicați-l pentru a-l muta într-o nouă poziție. Acest lucru protejează atât picioarele mobilierului, cât și pardoseala.

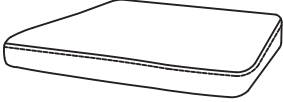
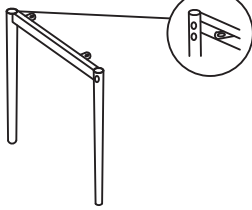
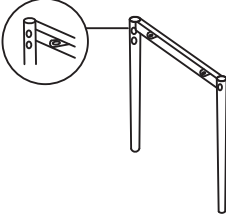
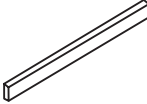
BOX 1-2

 <p>1 x 1</p>	 <p>2 x 2</p>	 <p>3 x 2</p>
 <p>4 x 2</p>	 <p>A x 8 M6*50 +1 (spare)</p>	 <p>B x 4 M6*25 +1 (spare)</p>
 <p>C x 6 +1 (spare)</p>	 <p>D x 12 +1 (spare)</p>	 <p>E x 1</p>

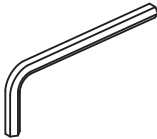
BOX 2-2

 <p>5 x 4</p>	 <p>6 x 4</p>	 <p>7 x 4</p>
 <p>8 x 4</p>	 <p>9 x 4</p>	 <p>F x 32 M6*20 +4 (spare)</p>
 <p>G x 8 M6*40 +2 (spare)</p>	 <p>H x 40 +4 (spare)</p>	 <p>I x 4</p>
 <p>J x 40 +4 (spare)</p>		

A x 8
M6*50



D x 8

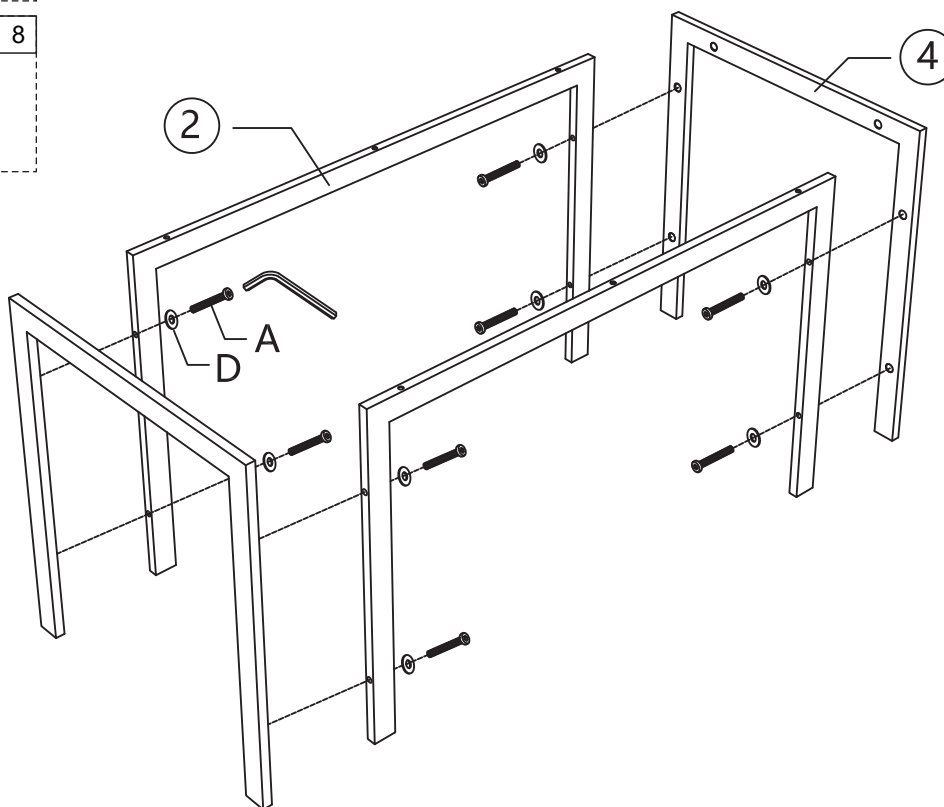

B x 4
M6*25

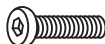

D x 4

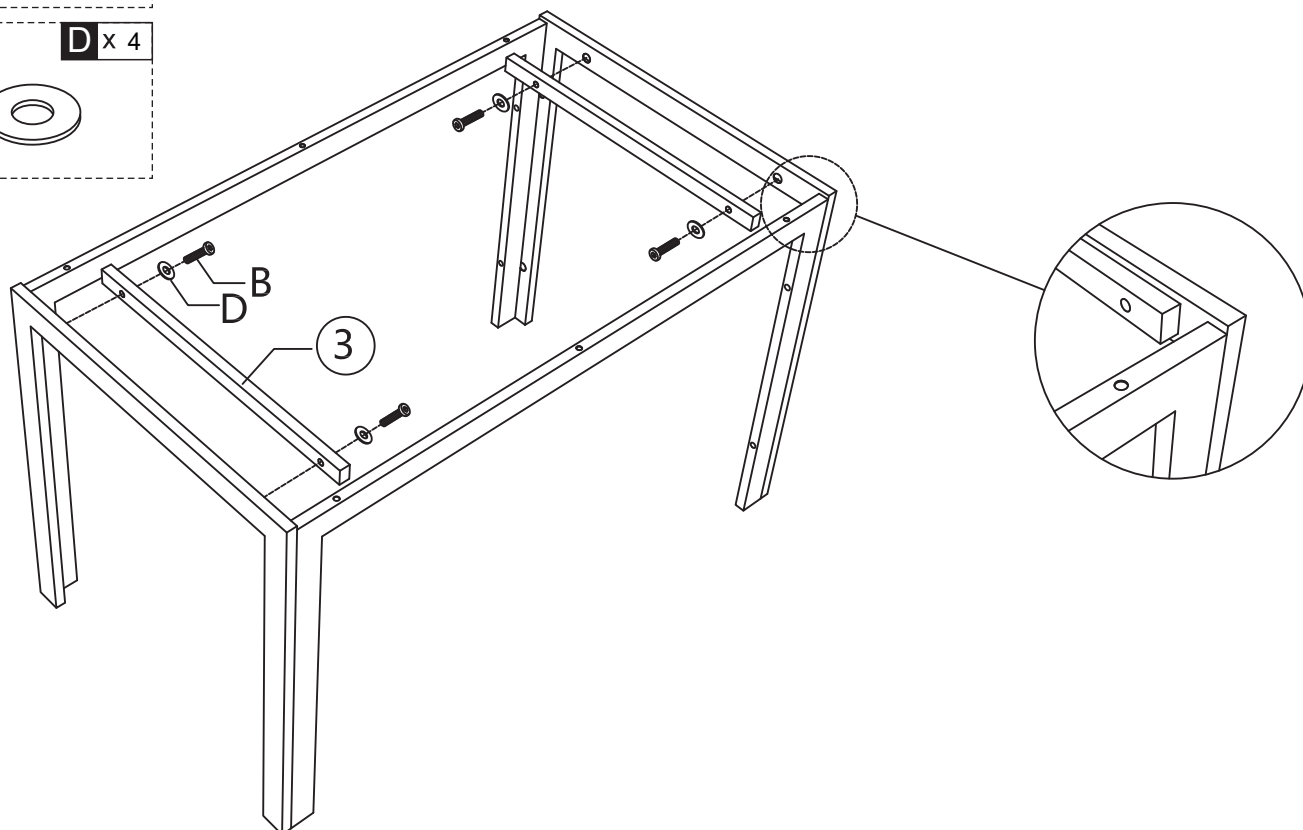

C x 6

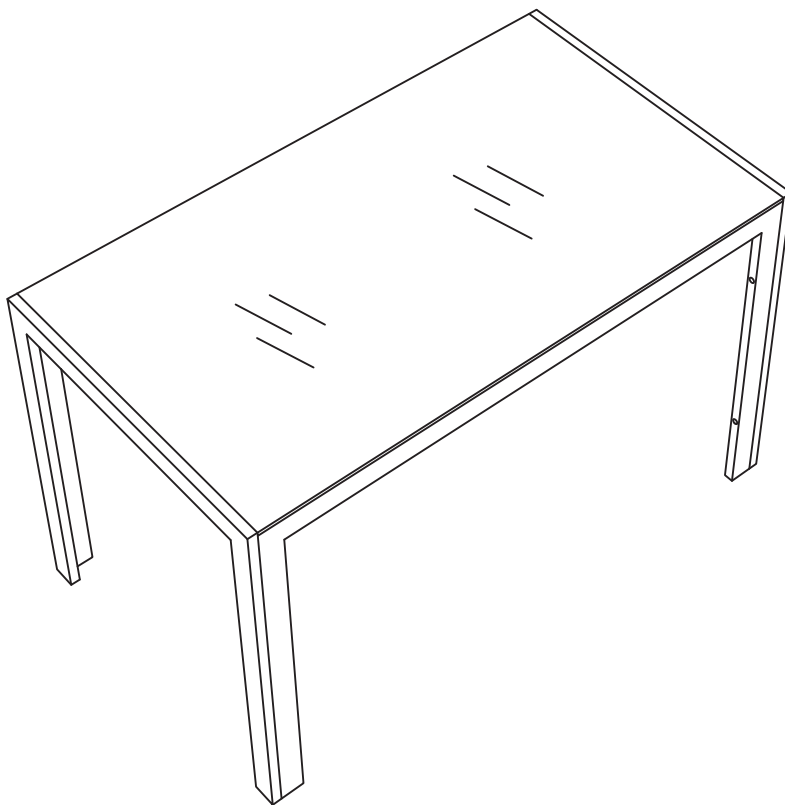
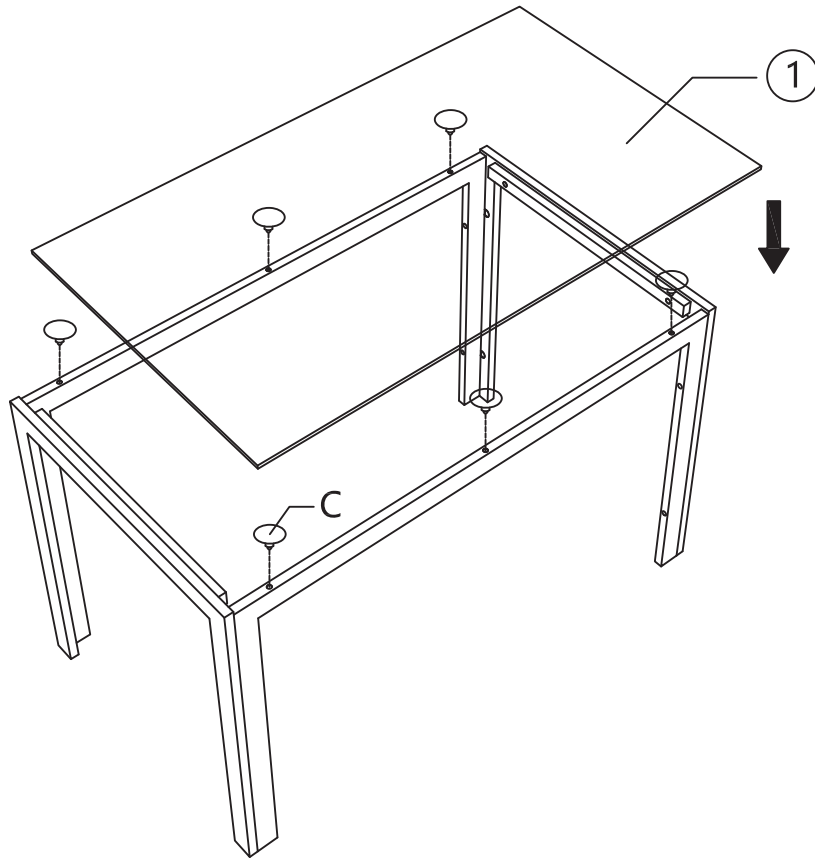

05

F x 16
M6*20



H x 16



J x 16



5

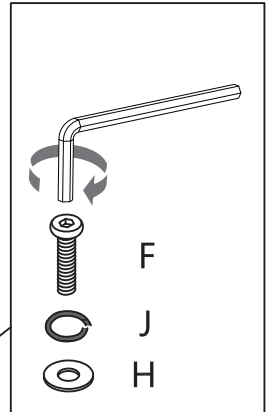
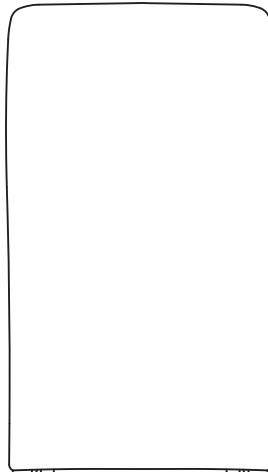
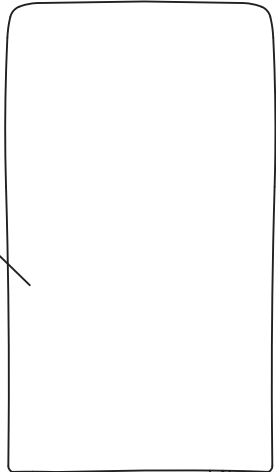

F

J

H

7

8

75%



x4

06

G x 8
M6*40



H x 8



J x 8



9

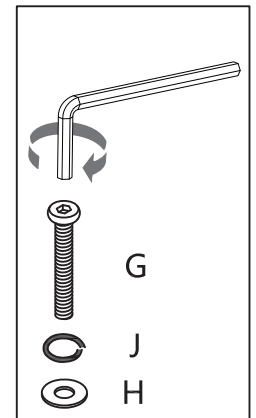
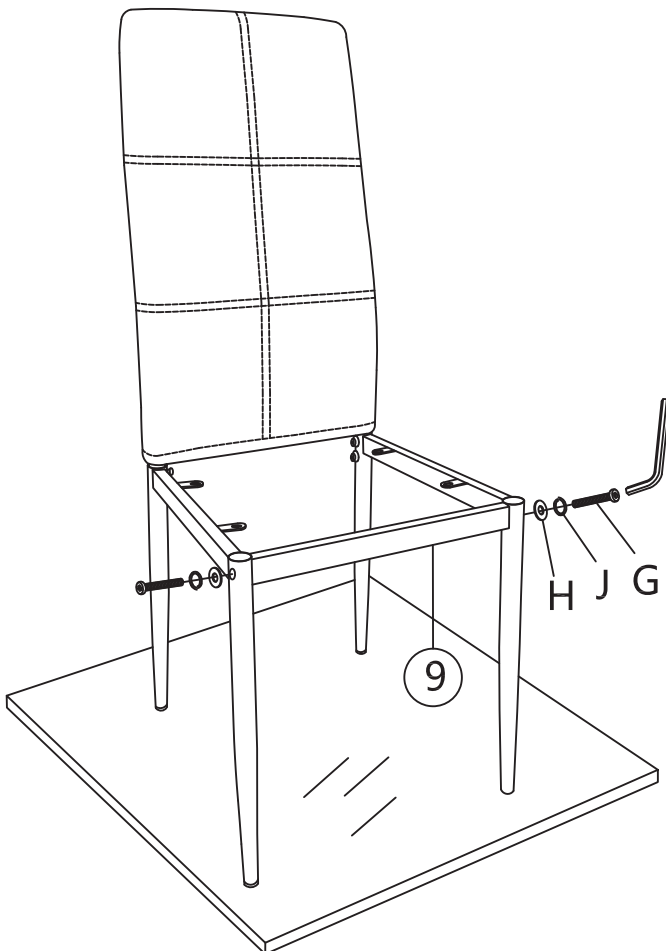

G

J

H

100%



x4

F x 16
M6*20

H x 16



J x 16

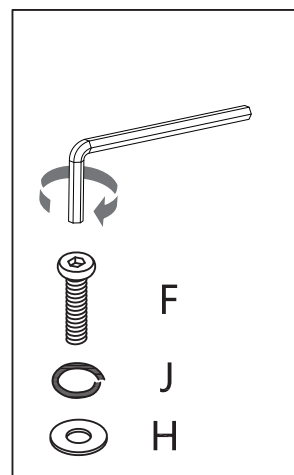
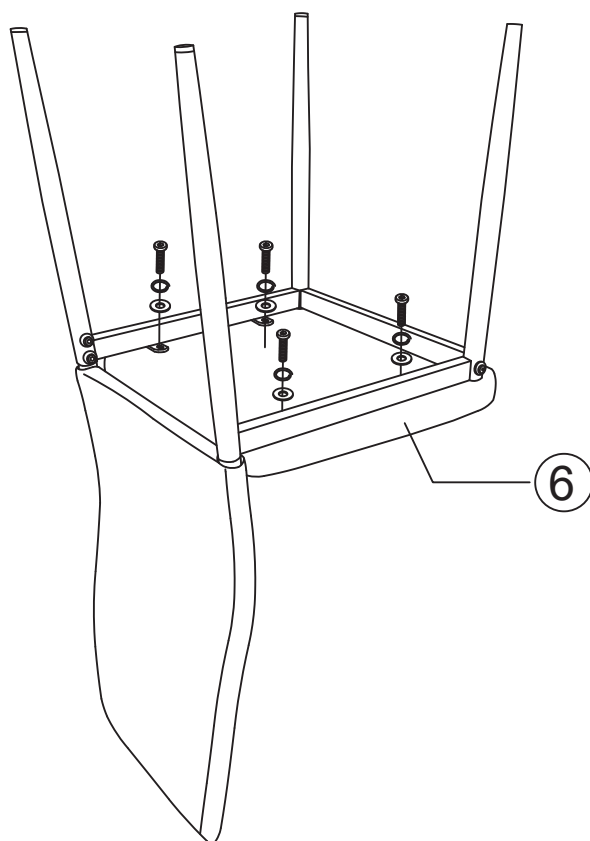

x4

Done

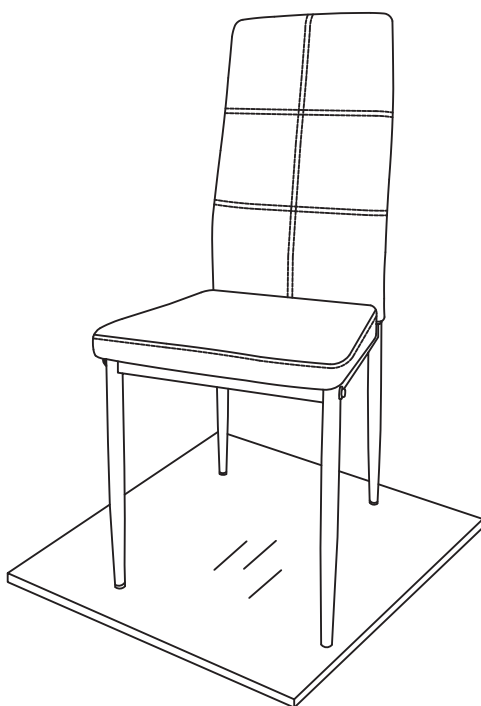

EN: Adjust the four feet until level, then tighten the screws.

FR: Ajustez les quatre pieds jusqu'à ce qu'ils soient de niveau, puis serrez les vis.

ES: Ajuste las cuatro patas hasta que queden niveladas, luego apriete los tornillos.

PT: Ajuste os quatro pés até ficarem nivelados, depois aperte os parafusos.

DE: Stellen Sie die vier FüÙe waagrecht ein, und ziehen Sie dann die Schrauben fest.

IT: Regolare i quattro piedini fino a metterli a livello, quindi stringere le viti.

RO: Reglați cele patru picioare până când sunt la nivel, apoi strângeți șuruburile.

x4

If you have any questions, please contact our customer care center, Our contact details are below:

US

 001-877-644-9366

 customerservice@aosom.com

Imported by Aosom LLC
7777 Center Ave. Suite 430
Huntington Beach, CA 92647-9998 USA
MADE IN CHINA

If you have any questions, please contact our customer care center, Our contact details are below:

CA

 416-792-6088

 customerservice@aosom.ca

Imported by Aosom Canada Inc.
Unit 33-1 Sparks Avenue, North York, Ontario,
Canada
M2H 2W1
MADE IN CHINA

Si vous avez la moindre question, veuillez contacter notre centre d'assistance à la clientèle, Nos coordonnées sont les suivantes:

 416-792-6088

 customerservice@aosom.ca

Importé par Aosom Canada Inc.
Unité 33-1 Sparks Avenue, North York, Ontario,
Canada M2H 2W1
Fabriqué en Chine

Si tiene alguna pregunta, comuníquese con nuestro Centro de Atención al Cliente, Nuestros datos de contacto son los siguientes:

ES

 0034-931294512

 atencioncliente@aosom.es

IMPORTADOR/Fabricante/REP:
SPANISH AOSOM, S.L.
C/ROC GROS, Nº15.08550, ELS HOSTALETES DE
BALENYÀ, SPAIN.
B66295775
HECHO EN CHINA

Se tiver alguma dúvida, por favor contacte o nosso Centro de Atendimento ao Cliente, Os nossos dados de contacto são os seguintes:

 0034-931294512

 info@aosom.pt.

Si vous avez la moindre question, veuillez contacter notre centre d'assistance à la clientèle, Nos coordonnées sont les suivantes:

FR

 0033-1-84166106

 aosom@mhfrance.fr

Importé par/Fabricant/REP:
MH FRANCE
2 Rue Maurice Hartmann
92130 Issy Les Moulineaux
France
FABRIQUÉ EN CHINE



FR

**DONNEZ
OU
RECYCLEZ**



ASSOCIATION

OU



LIVRAISON

OU



DÉCHÈTERIE

Adresses sur quefairedemesdechets.fr

If you have any questions, please contact our customer care center, Our contact details are below:

UK

 0044-800-240-4004

 enquiries@mhstar.co.uk

IMPORTER ADDRESS:
MH STAR UK LTD
1 Northampton Cross Logistics Park
Northampton Cross Road
Northampton
Nn4 9FH
Tel: 0800 240 4050
enquiries@mhstar.co.uk
MADE IN CHINA

Wenn Sie Fragen haben, wenden Sie sich bitte an unser Kundendienstzentrum, Unsere Kontaktdaten stehen unten:

DE

 0049-0(40)-87408465

 service@aosom.de

ADRESSE DES IMPORTEURE/Hersteller/REP:
MH Handel GmbH
Wendenstraße 309
D-20537 Hamburg
Germany
IN CHINA HERGESTELLT

In caso di dubbio, si prega di contattare il nostro centro assistenza clienti, I nostri dettagli di contatto sono di seguito:

IT

 0039-0249471447

 clienti@aosom.it

IMPORTATO DA/Produttore/REP:
AOSOM Italy srl
Centro Direzionale Milanofiori
Strada 1 Palazzo F1
20057 Assago (MI)
P.I.: 08567220960
FATTO IN CINA

Importator/Producător/REP:

RO

Aosom Romania SRL
Str. Barbu Mumuleanu, nr. 30-32
Bucuresti, Sector 2
Tel: +40 312294730
clienti@aosom.ro
Fabricat in China